

On the Optimality of Certainty Equivalence for Event-triggered Control Systems

Adam Molin, *Member, IEEE*, and Sandra Hirche, *Senior Member, IEEE*

Abstract

Digital control design is commonly constrained to time-triggered control systems with periodic sampling. The emergence of more and more complex and distributed systems urges the development of advanced triggering schemes that utilize communication, computation, and energy resources more efficiently. This paper addresses the question whether certainty equivalence is optimal for an event-triggered control system with resource constraints. The problem setting is an extension of the stochastic linear quadratic system framework, where the joint design of the control law and the event-triggering law minimizing a common objective is considered. Three differing variants are studied that reflect the resource constraints: a penalty term to acquire the resource, a limitation on the number of resource acquisitions, and a constraint on the average number of resource acquisitions. By reformulating the underlying optimization problem, a characterization of the optimal control law is possible. This characterization shows that the certainty equivalence controller is optimal for all three optimization problems.

Index Terms

Event-triggered control, certainty equivalence, networked control systems, resource-aware control, stochastic optimal control

I. INTRODUCTION

Recent technological advances in communications, embedded systems and sensing have raised the interest in the analysis and design of resource-constrained control systems. Energy, com-

A. Molin and S. Hirche are with the Institute of Automatic Control Engineering, Technische Universität München, Arcisstraße 21, D-80290 München, Germany; <http://www.lsr.ei.tum.de>, e-mail: adam.molin@tum.de, hirche@tum.de. This work was supported in part by the German Research Foundation (DFG) within the Priority Program SPP 1305 "Control Theory of Digitally Networked Dynamical Systems".

putation, and communication limitations have inspired the control community to search for advanced transmission schemes beyond the time-triggered periodic scheme, e.g., [1]–[5]. The results are related to the domain of control over communications [1], [2], multi-agent systems [3], distributed optimization algorithms [4], and embedded control design [5]. The underlying design methodologies usually presume an a-priori defined control law on which the event-triggering strategies are established. In other words, the choice for the control law does not take into account resource constraints for updating the controller.

This motivates us to ask what structural properties a control law must have to be optimally suited for an event-triggered transmission scheme. In particular, the open question addressed in this note is whether a certainty equivalence controller is still optimal for event-triggered systems in the presence of resource constraints.

There exists several results that are related to the problem setting in this note. The design of optimal event-triggered control for stochastic continuous-time systems is studied in [6] for a limited number of control updates with the control waveform restrained to be constant between transmissions. The problem is shown to be related to optimal stopping time problems, which enable an analytical solution in certain cases. In [7], the problem of optimally assigning a limited number of state resets is considered. For a finite-horizon LQG control problem, it is shown that time-varying thresholds of the state signal are optimal for triggering a state reset. Optimal sensor querying and control within the LQG framework with costly queries has been studied by [8], [9]. It is found that the optimal control law is certainty equivalent and the timings for queries can be determined offline. Rather than limiting the number of update transmissions, the control problems stated in [10]–[12] pose constraints on the number of bits that may be transmitted over a resource-constrained channel per time step. Inspired by [10], it is shown in [11], [12] that the certainty equivalence controller is optimal within the LQG framework under such communication constraints. The design of optimal event-triggered control where the event-trigger and the controller are merely restricted to be causal mappings of their observations has not been addressed in the aforementioned literature and is the subject of this note.

Our contribution is to show that a certainty equivalence controller is optimal under three variants of resource constraints. The system model under consideration can be regarded as an extension of the stochastic linear quadratic systems framework. The optimal event-triggered control design consists of developing (i) an optimal control law and (ii) an optimal event-trigger

at the sensor. At every time instance, the event-trigger decides upon its observations whether it is worth to update the controller with a current measurement. Based on the available information, the control law applies control inputs to regulate the process. Three different types of resource constraints are considered. The first one is inspired by work in [13] and penalizes every controller update with an additional cost. The other two resource constraints restrain either the number of updates as appeared in [6], [7] or its average. As the information available at the control station and the sensor station differ, the present stochastic optimal control problem has a non-classical information pattern [14]. This is in contrast to the aforementioned works, which recover a classical information pattern [6]–[9]: Either control decisions are taken only at update times [6], [7] limiting the number of admissible policies, or, rather than letting the sensor decide, the controller decides if it shall receive updates [8], [9]. Opposed to these approaches, our problem setting prohibits the application of common tools of stochastic optimal control because of the non-classical information pattern. Therefore, we develop a reformulation technique for the underlying optimization problem that enables a characterization of the optimal control law. Without having to determine the optimal event-triggering policy, we are able to state that the certainty-equivalence controller is optimal for all three optimization problems. A preliminary version of this work first appeared in the conference paper [15].

The remaining part is organized as follows. Section II introduces the system model and the three problem settings to be analyzed. By using a reformulated problem setting, optimal control policies are characterized in section III. In section IV, extensions and limitations of the obtained results are discussed and section V gives concluding remarks.

Notation. In this paper, the operator $(\cdot)^T$ denotes the transpose operator of a matrix. The expectation operator is denoted by $E[\cdot]$ and the conditional expectation is denoted by $E[\cdot|\cdot]$. The sequence of a signal x_k is denoted by $\{x_k\}$. The truncated sequence up to time k is denoted by $X^k = \{x_0, \dots, x_k\}$. For Greek letters, a sequence $\{\delta_k\}$ up to time k is denoted by δ^k . With abuse of notation, we interpret X^k as a set, when referring to its information and as a column vector, when referring to its signal evolution.

II. PROBLEM FORMULATION

The system under consideration is illustrated in Figure 1 and can be viewed as a resource-constrained control system. For the sake of illustration, the constraint is represented by a resource-

constrained communication channel \mathcal{N} . The other part of the system consists of a process \mathcal{P} , an event-trigger \mathcal{E} , and a controller \mathcal{C} . The stochastic discrete-time process \mathcal{P} to be controlled is described by the following time-invariant difference equation

$$x_{k+1} = Ax_k + Bu_k + w_k, \quad (1)$$

where $A \in \mathbb{R}^{n \times n}$, $B \in \mathbb{R}^{n \times d}$. The variables x_k and u_k denote the state and the control input and are taking values in \mathbb{R}^n and \mathbb{R}^d , respectively. The initial state x_0 is a random variable with finite mean and covariance. The system noise process $\{w_k\}$ is i.i.d. (independent identically distributed) and w_k takes values in \mathbb{R}^n and is zero-mean and has finite covariance. The random variables x_0 and w_k are statistically independent for each k . Let $(\Omega, \mathcal{A}, \mathbb{P})$ denote the probability space generated by the initial state x_0 and noise sequence $\{w_k\}$. We call x_0 and w_k the primitive random variables of the system. The statistics of the process \mathcal{P} are known a-priori to both, the event-trigger \mathcal{E} and the controller \mathcal{C} . It should be remarked that the results in this note also apply for time-variant systems. The consideration of time-invariant systems is because of notational convenience.

The event-trigger \mathcal{E} situated at the sensor station has access to the complete state information and decides, whether the controller \mathcal{C} should receive an update over the feedback channel \mathcal{N} . The controller calculates inputs u_k to regulate the process \mathcal{P} .

Concerning our system model, it is needed to define the amount of information available at the control station at each time step k . The output signal of the event-trigger, δ_k , takes values in $\{0, 1\}$ deciding whether information is transmitted at time k , i.e.,

$$\delta_k = \begin{cases} 1, & \text{measurement } x_k \text{ sent,} \\ 0, & \text{no measurement transmitted.} \end{cases}$$

Therefore, the signal y_k is defined as

$$y_k = \begin{cases} x_k, & \delta_k = 1, \\ \emptyset, & \delta_k = 0. \end{cases} \quad (2)$$

As various steps of decisions are made within one time period k , a causal ordering is specified by the following sequence in which the events within the system occur.

$$\cdots \rightarrow x_k \rightarrow \delta_k \rightarrow y_k \rightarrow u_k \rightarrow x_{k+1} \rightarrow \cdots$$

Establishing such time-ordering in advance can be crucial for optimal policies, particularly, when having distributed decision-makers [16]. We allow the control input and the event-triggering output to depend on their complete past history. Let the event-triggering law $f = \{f_0, f_1, \dots, f_{N-1}\}$ and the control law $\gamma = \{\gamma_0, \gamma_1, \dots, \gamma_{N-1}\}$ denote admissible policies for the finite horizon N with

$$\delta_k = f_k(X^k), \quad u_k = \gamma_k(Y^k).$$

We assume that the mappings f_k and γ_k are measurable mappings of their available information X^k and Y^k , respectively.

We define the information available at the event-trigger and the controller at time step k as the σ -algebra generated by X^k and Y^k , respectively. These are denoted by $\mathcal{I}_k^\mathcal{E}$ and $\mathcal{I}_k^\mathcal{C}$. It should be noticed that $\mathcal{I}_k^\mathcal{C} \subset \mathcal{I}_k^\mathcal{E}$ because y_k can be expressed as a function of X^k implying that the information available at the controller can be recovered by the event-trigger. Since we assume the control law to be deterministic, and we have $\mathcal{I}_k^\mathcal{C} \subset \mathcal{I}_k^\mathcal{E}$, the control inputs U^{k-1} are known by the event-trigger at time k .

The communication channel \mathcal{N} takes the role of restricting or penalizing transmissions in the feedback loop. This will be reflected in the optimization problem. Let $J_{\mathcal{C}}$ be the control objective defined as

$$J_{\mathcal{C}} = x_N^T Q_N x_N + \sum_{k=0}^{N-1} x_k^T Q x_k + u_k^T R u_k, \quad (3)$$

and let $J_{\mathcal{E}}$ be the communication cost given by the number of transmissions, i.e.,

$$J_{\mathcal{E}} = \sum_{k=0}^{N-1} \delta_k. \quad (4)$$

We consider three different optimization problems that shall be analyzed in the next section.

Problem A: Let $\lambda \geq 0$. Find the optimal f^* and γ^* that

$$\inf_{f, \gamma} \mathbf{E} [J_{\mathcal{C}} + \lambda J_{\mathcal{E}}].$$

Problem B: Let m be a non-negative integer. Find the optimal f^* and γ^* that

$$\inf_{f, \gamma} \mathbf{E} [J_{\mathcal{C}}], \quad \text{s.t. } J_{\mathcal{E}} \leq m.$$

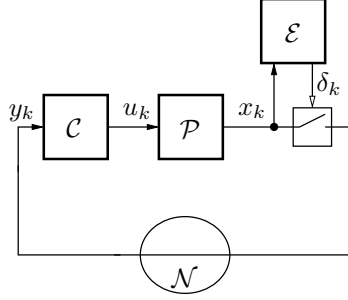

Fig. 1. System model of the resource-constrained control system with process \mathcal{P} , event-trigger \mathcal{E} , controller \mathcal{C} , and communication channel \mathcal{N} .

Problem C: Let $\bar{m} \geq 0$. Find the optimal f^* and γ^* that

$$\inf_{f, \gamma} \mathbb{E}[J_{\mathcal{C}}], \quad \text{s.t. } \mathbb{E}[J_{\mathcal{E}}] \leq \bar{m}.$$

Let us denote \mathcal{U} to be the set of all admissible policy pairs (f, γ) . For notational convenience, we define the cost function $J(f, \gamma)$ for $(f, \gamma) \in \mathcal{U}$ to be

$$J(f, \gamma) = \begin{cases} \mathbb{E}[J_{\mathcal{C}} + \lambda J_{\mathcal{E}}] & \text{for Problem A,} \\ \mathbb{E}[J_{\mathcal{C}}] & \text{for Problem B,C.} \end{cases} \quad (5)$$

Problems A-C can be regarded as two person team problems with a non-classical information pattern, where the decision-makers are given by the event-trigger and the controller. Optimization problems A and C imply a soft constraint on the number of transmissions during time interval N , whereas Problem B poses a hard constraint on the number of transmissions, which is to be fulfilled for every sample path $\omega \in \Omega$. It could be conjectured that Problem A and Problem C are equivalent for appropriate choices of λ and \bar{m} . But as we can not assert that all solutions of Problem C can be reached through Problem A for varying weight λ , we regard them as different problems.¹

III. CHARACTERIZATION OF OPTIMAL CONTROL POLICIES

Finding the joint optimal policies of the event-triggered controller is in general difficult for all three problem settings. The controller and event-trigger have different information available,

¹A sufficient condition that both problems are equivalent is given by showing that the set of Pareto-optimal points in \mathbb{R}^2 of the vector optimization with cost vector $[\mathbb{E}[J_{\mathcal{C}}], \mathbb{E}[J_{\mathcal{E}}]]^T$ are boundary points of a convex set [17].

and it is well known that such problems are usually very hard to solve [18]. Stochastic control problems with non-classical information pattern generally do not allow to apply concepts like dynamic programming directly.

Nevertheless, it is possible to obtain structural results of the optimal solution. The key idea that yields such structural result is based on the following common concept in optimal control.

Definition 1 (Dominating policies): A set of policy pairs $\mathcal{U}' \subset \mathcal{U}$ is called a *dominating class of policies* for problems A, B, or C, if for any feasible $(f, \gamma) \in \mathcal{U}$, there exists a feasible $(f', \gamma') \in \mathcal{U}'$, such that

$$J(f', \gamma') \leq J(f, \gamma),$$

where J is the cost function defined by (5) for the corresponding problem.

Once a dominating class of policies is found, the above definition implies that we can restrict the solutions of the optimization problem to such policies. Subsequently, we show that the set of policy pairs where the controller is a certainty equivalence controller denoted by γ^* is a dominating class of policies. A certainty equivalence controller is given by solving a related deterministic control problem, where all primitive random variables are set to their means, and by replacing the state variable by its least squares estimate within the deterministic solution. The remaining goal is to prove that for any pair (f, γ) , we can find a pair (f', γ^*) whose costs are at most that of (f, γ) .

In order to achieve this, we introduce a suitable reparametrization of the triggering law. Given a policy (f, γ) , we define another policy (g, γ) where $g = \{g_0, \dots, g_{N-1}\}$ is the triggering law, and g_k is a function of $\{x_0, W^{k-1}\}$, such that

$$g_k(x_0, W^{k-1}) = f_k(X^k), \quad k \in \{0, \dots, N-1\}, \omega \in \Omega, \quad (6)$$

when both systems use the control law γ . As the control inputs U^{k-1} are known at the event-trigger at time k by the law γ due to $\mathcal{I}_k^C \subset \mathcal{I}_k^E$, the variables $\{x_0, W^{k-1}\}$ can be fully recovered by the state sequence X^k and vice versa. Therefore, the triggering law g satisfying (6) always exists. On the other hand, this also implies that given (g, γ) , there is always a (f, γ) satisfying (6).

The next intermediate result states on the optimal control law for fixed g .

Lemma 1: Let the triggering law g be a function of primitive variables given by

$$\delta_k = g_k(x_0, W^{k-1}), \quad k \in \{0, \dots, N-1\}. \quad (7)$$

If the triggering law g is fixed, then the optimal control law γ^* minimizing $J(g, \gamma)$ of problems A-C is a certainty equivalence controller given by

$$u_k = \gamma_k^*(Y^k) = -L_k \mathbf{E}[x_k | \mathcal{I}_k^C], \quad k \in \{0, \dots, N-1\} \quad (8)$$

with

$$\begin{aligned} L_k &= (R + B^T P_{k+1} B)^{-1} B^T P_{k+1} A, \\ P_k &= A^T P_{k+1} A + Q - A^T P_{k+1} B (R + B^T P_{k+1} B)^{-1} B^T P_{k+1} A, \end{aligned} \quad (9)$$

where $P_N = Q_N$ and $P_k \in \mathbb{R}^{n \times n}$ is non-negative definite for $k \in \{0, \dots, N\}$.

Proof: Since g is fixed, the output δ_k is a random variable described by a function of primitive random variables that is independent of the choice of the control law γ . In case of Problem A, this implies that $\mathbf{E}[J_{\mathcal{E}}]$ is a constant for a fixed g . With regard to Problem B and C, it implies that the choice of g determines uniquely whether the constraints are satisfied irrespectively from the control law γ . Thus, solving the optimization problems A-C for a fixed g reduces to minimizing $\mathbf{E}[J_{\mathcal{C}}]$ over all admissible control laws γ . The resulting objective function is purely quadratic, and tools from stochastic control can be applied [19]. Similarly to [19], we first show that the estimation error at the controller defined by

$$e_k = x_k - \mathbf{E}[x_k | \mathcal{I}_k^C] \quad (10)$$

is a random variable that can be described as a function of primitive random variables x_0 and W^{k-1} which is independent of the control law γ . Let us fix a control law γ and consider two types of systems: a forced and an un-forced system. In the first system, control inputs are determined by the law γ and the system evolves by equation (1) and (2), whereas the second system has zero-input and is given by

$$\begin{aligned} \tilde{x}_{k+1} &= A\tilde{x}_k + \tilde{w}_k, \\ \tilde{y}_k &= \begin{cases} \tilde{x}_k, & \tilde{\delta}_k = 1, \\ \emptyset, & \tilde{\delta}_k = 0. \end{cases} \end{aligned}$$

We assume the primitive random variables are identical for both systems, i.e.,

$$\tilde{x}_0 = x_0, \quad \tilde{w}_k = w_k, \quad k = 0, \dots, N-1. \quad (11)$$

Since the triggering output δ_k is a function of primitive random variables defined by (7) that is independent of γ , we have

$$\tilde{\delta}_k = \delta_k, \quad k = 0, \dots, N-1.$$

Because of linearity, we can rewrite the systems into the following matrix-vector notation

$$\begin{aligned} x_k &= F_k x_0 + G_k U^{k-1} + H_k W^{k-1}, \\ \tilde{x}_k &= F_k x_0 + H_k W^{k-1}, \end{aligned}$$

where U^{k-1} , W^{k-1} are the augmented signal vectors and F_k , G_k , and H_k are appropriate matrices constructed from A and B . As U^{k-1} is measurable with respect to the information pattern \mathcal{I}_k^C , the conditional expectations are given by

$$\begin{aligned} \mathbb{E}[x_k | \mathcal{I}_k^C] &= F_k \mathbb{E}[x_0 | \mathcal{I}_k^C] + G_k U^{k-1} + H_k \mathbb{E}[W^{k-1} | \mathcal{I}_k^C], \\ \mathbb{E}[\tilde{x}_k | \mathcal{I}_k^C] &= F_k \mathbb{E}[x_0 | \mathcal{I}_k^C] + H_k \mathbb{E}[W^{k-1} | \mathcal{I}_k^C]. \end{aligned}$$

Hence, we obtain

$$x_k - \mathbb{E}[x_k | \mathcal{I}_k^C] = \tilde{x}_k - \mathbb{E}[\tilde{x}_k | \mathcal{I}_k^C].$$

Given the laws γ and g , it is trivial to show that there exists a bijective mapping between Y^k and \tilde{Y}^k . This implies that the σ -algebra $\tilde{\mathcal{I}}_k^C$ generated by \tilde{Y}^k is identical to \mathcal{I}_k^C . This is because the vectors δ^k and $\tilde{\delta}^k$ are identical random variables, and

$$\tilde{y}_k = \begin{cases} y_k - G_k U^{k-1}, & \delta_k = 1, \\ \emptyset, & \delta_k = 0, \end{cases}$$

while

$$\begin{aligned} y_0 &= \tilde{y}_0, & u_0 &= \gamma_0(y_0) = \gamma_0(\tilde{y}_0), \\ y_1 &= \begin{cases} \tilde{y}_0 + G_1 \gamma_0(\tilde{y}_0), & \tilde{\delta}_1 = 1, \\ \emptyset, & \tilde{\delta}_1 = 0, \end{cases} \\ u_1 &= \begin{cases} \gamma_1(\tilde{y}_0, \tilde{y}_0 + G_1 \gamma_0(\tilde{y}_0)), & \tilde{\delta}_1 = 1, \\ \gamma_1(\tilde{y}_0), & \tilde{\delta}_1 = 0, \end{cases} \\ &\vdots \end{aligned}$$

Therefore, we can write

$$e_k = \tilde{x}_k - \mathbf{E}[\tilde{x}_k | \tilde{\mathcal{I}}_k^{\mathcal{C}}]. \quad (12)$$

Since $\tilde{x}_k - \mathbf{E}[\tilde{x}_k | \tilde{\mathcal{I}}_k^{\mathcal{C}}]$ in Equation (12) can be expressed in terms of primitive random variables and is independent of the control law γ , we showed that the estimation error e_k is given by a function of primitive random variables which is independent of γ .

Next, we use the identity to reformulate $J_{\mathcal{C}}$ defined by (3), see lemma 6.1 of chapter 8 in [20] that is given by

$$\begin{aligned} J_{\mathcal{C}} &= x_0^{\mathbf{T}} P_0 x_0 + \sum_{k=0}^{N-1} (u_k + L_k x_k)^{\mathbf{T}} (B^{\mathbf{T}} P_{k+1} B + R) (u_k + L_k x_k) \\ &\quad + \sum_{k=0}^{N-1} w_k^{\mathbf{T}} P_{k+1} (A x_k + B u_k) + (A x_k + B u_k)^{\mathbf{T}} P_{k+1} w_k \\ &\quad + \sum_{k=0}^{N-1} w_k^{\mathbf{T}} P_{k+1} w_k, \end{aligned}$$

where L_k and P_k are given by (9). Let us define

$$\Gamma_k = B^{\mathbf{T}} P_{k+1} B + R, \quad k \in \{0, \dots, N-1\}.$$

By taking expectation and incorporating independence of w_k with respect to x_k and u_k , we have

$$\begin{aligned} \mathbf{E}[J_{\mathcal{C}}] &= \mathbf{E}[x_0^{\mathbf{T}} P_0 x_0] + \mathbf{E}\left[\sum_{k=0}^{N-1} w_k^{\mathbf{T}} P_{k+1} w_k\right] \\ &\quad + \mathbf{E}\left[\sum_{k=0}^{N-1} (u_k + L_k x_k)^{\mathbf{T}} \Gamma_k (u_k + L_k x_k)\right]. \end{aligned}$$

The first two terms are constant and can be omitted from the optimization. After replacing x_k with $\mathbf{E}[x_k | \tilde{\mathcal{I}}_k^{\mathcal{C}}] + e_k$, we have

$$\begin{aligned} &(u_k + L_k x_k)^{\mathbf{T}} \Gamma_k (u_k + L_k x_k) = \\ &= (u_k + L_k \mathbf{E}[x_k | \tilde{\mathcal{I}}_k^{\mathcal{C}}] + L_k e_k)^{\mathbf{T}} \Gamma_k (u_k + L_k \mathbf{E}[x_k | \tilde{\mathcal{I}}_k^{\mathcal{C}}] + L_k e_k) \\ &= (u_k + L_k \mathbf{E}[x_k | \tilde{\mathcal{I}}_k^{\mathcal{C}}])^{\mathbf{T}} \Gamma_k (u_k + L_k \mathbf{E}[x_k | \tilde{\mathcal{I}}_k^{\mathcal{C}}]) \\ &\quad + (u_k + L_k \mathbf{E}[x_k | \tilde{\mathcal{I}}_k^{\mathcal{C}}])^{\mathbf{T}} \Gamma_k L_k e_k + e_k^{\mathbf{T}} L_k^{\mathbf{T}} \Gamma_k (u_k + L_k \mathbf{E}[x_k | \tilde{\mathcal{I}}_k^{\mathcal{C}}]) \\ &\quad + e_k^{\mathbf{T}} L_k^{\mathbf{T}} \Gamma_k L_k e_k. \end{aligned} \quad (13)$$

By applying the tower property of conditional expectations, we obtain

$$\begin{aligned} \mathbb{E}[(u_k + L_k \mathbb{E}[x_k | \mathcal{I}_k^{\mathcal{C}}])^{\text{T}} \Gamma_k L_k e_k] &= \\ &= \mathbb{E}[\mathbb{E}[(u_k + L_k \mathbb{E}[x_k | \mathcal{I}_k^{\mathcal{C}}])^{\text{T}} \Gamma_k L_k e_k | \mathcal{I}_k^{\mathcal{C}}]] \\ &= \mathbb{E}[(u_k + L_k \mathbb{E}[x_k | \mathcal{I}_k^{\mathcal{C}}])^{\text{T}} \Gamma_k L_k \mathbb{E}[e_k | \mathcal{I}_k^{\mathcal{C}}]]. \end{aligned}$$

The second equality is because $u_k = \gamma_k(\mathcal{I}_k^{\mathcal{C}})$ and $\mathbb{E}[x_k | \mathcal{I}_k^{\mathcal{C}}]$ are measurable functions with respect to $\mathcal{I}_k^{\mathcal{C}}$. In fact,

$$\begin{aligned} \mathbb{E}[e_k | \mathcal{I}_k^{\mathcal{C}}] &= \mathbb{E}[x_k | \mathcal{I}_k^{\mathcal{C}}] - \mathbb{E}[\mathbb{E}[x_k | \mathcal{I}_k^{\mathcal{C}}] | \mathcal{I}_k^{\mathcal{C}}] \\ &= \mathbb{E}[x_k | \mathcal{I}_k^{\mathcal{C}}] - \mathbb{E}[x_k | \mathcal{I}_k^{\mathcal{C}}] = 0. \end{aligned}$$

Thus, the cross terms in Equation (13) vanish and we obtain

$$\begin{aligned} \mathbb{E}[J_{\mathcal{C}}] &= \mathbb{E}[x_0^{\text{T}} P_0 x_0] + \mathbb{E}\left[\sum_{k=0}^{N-1} w_k^{\text{T}} P_{k+1} w_k\right] + \mathbb{E}\left[\sum_{k=0}^{N-1} e_k^{\text{T}} L_k^{\text{T}} \Gamma_k L_k e_k\right] \\ &\quad + \mathbb{E}\left[\sum_{k=0}^{N-1} (u_k + L_k \mathbb{E}[x_k | \mathcal{I}_k^{\mathcal{C}}])^{\text{T}} \Gamma_k (u_k + L_k \mathbb{E}[x_k | \mathcal{I}_k^{\mathcal{C}}])\right]. \end{aligned} \quad (14)$$

As the first three terms are constant, we observe that $\mathbb{E}[J_{\mathcal{C}}]$ attains its minimum for γ^* given by Equation (8). This concludes the proof. \blacksquare

Built upon this intermediate result, we obtain the following theorem which states the main result of this note.

Theorem 1: Let the system be given by (1) and (2). The class of policies $\mathcal{U}_{\text{CE}} \subset \mathcal{U}$ defined by

$$\mathcal{U}_{\text{CE}} = \{(f, \gamma^*) \mid \gamma^* = -L_k \mathbb{E}[x_k | \mathcal{I}_k^{\mathcal{C}}], L_k \text{ given by (9)}\}$$

is a dominating class of policies for the problem settings A-C.

Proof: According to Definition 1, it suffices to show that for any feasible pair $(f, \gamma) \in \mathcal{U}$, there is a feasible policy $(f', \gamma^*) \in \mathcal{U}_{\text{CE}}$ whose costs are at most that of (f, γ) .

Given a feasible pair (f, γ) , there exists a feasible pair (g, γ) with g_k being a function of primitive variables that satisfies (6). Condition (6) implies that for (f, γ) and (g, γ) , we have identical random variables u_k and δ_k for $k \in \{0, \dots, N-1\}$ and therefore identical costs. In the same way for the pair (g, γ^*) , we can find a triggering law f' being a function of X^k , such that

both (g, γ^*) and (f', γ^*) output identical random variables u_k and δ_k for $k \in \{0, \dots, N-1\}$. Due to Lemma 1, we obtain

$$J(f, \gamma) = J(g, \gamma) \geq \min_{\gamma} J(g, \gamma) = J(g, \gamma^*) = J(f', \gamma^*).$$

Since (g, γ^*) is feasible, the pair (f', γ^*) is also feasible. This concludes the proof. \blacksquare

IV. DISCUSSION

Theorem 1 implies that we can characterize optimal control policies to be certainty equivalent control laws given by (8). Characterizing the optimal solution by Theorem 1 opens up the possibility of calculating the optimal event-triggered controller with standard approaches. The remaining problem to solve Problems A-C is discussed in the next paragraph. Apart from that, we comment on extensions and limitations of the obtained result. There, it can be noticed that Theorem 1 also holds for noisy measurements and certain types of communication models.

1) *Design of the optimal event-triggering law f^** : Given Theorem 1, designing the optimal event-triggering law can be considered as the joint optimization of the estimator $E[x_k | \mathcal{I}_k^C]$ and the event-trigger f , which has been already studied in the literature. This has been addressed for Problem A in [13], [15], [21] and for Problem B in [22], [23]. Assuming that the distributions of the primitive random variables are symmetric, the work in [21] shows for first-order linear systems that the optimal event-trigger is a symmetric threshold function and the state estimator is given by a linear predictor. For higher-order systems, this result remains unproven. Under the restriction to symmetric policies, the optimal event-triggering law f^* can be calculated by dynamic programming as discussed in [13], [15]. In case of Problem C the remaining problem can be posed in the framework of constrained Markov decision processes [24].

2) *Noisy state observation*: Under the assumption that only noisy observations are available, Theorem 1 is still valid if the right-hand side of the measurement equation is linear in the state variable. On the assumption that the transmitted information is measurable with respect to \mathcal{I}_k^E , it still holds that $\mathcal{I}_k^C \subset \mathcal{I}_k^E$. Applying a reparametrization of the policy pair as presented in [25], the argumentation in Section III carries over to noisy observations and the certainty equivalence controller is optimal for problems A-C.

3) *Zero-order hold control waveform*: If we restrain the control waveform to be constant between transmissions as in [6], the proposed reparametrization technique is still valid. Nevertheless, it is not possible to eliminate the last term in (14) due to the fact that u_k must be

constant between transmissions. This implies that the costs can not be completely decoupled and our results can not be extended to this case.

4) *Fixed event-triggering laws*: It is clear that, when the event-triggering law is predefined in advance, no structural properties can be characterized in general. An exception is [26], where symmetric event-triggering laws are studied. Within this special class of event-triggering laws, it is shown that certainty equivalence controllers are optimal for a quadratic cost function.

5) *Communication models*: When introducing more realistic models for the communication channels with packet dropouts and time-delay, it has been shown in [27] that certainty equivalence is still optimal if an instantaneous error-free acknowledgement channel exists. In the presence of time-delays in the acknowledgement channel, the paper [27] shows that certainty equivalence is optimal when allowing to have only one unacknowledged packet in the system at each time step k .

V. CONCLUSION

This work shows that the certainty equivalence controller is optimal for an extended LQG framework that incorporates communication constraints. The communication constraints are set within the packet level of the communication network restraining the number of transmissions. This result opens up the possibility to calculate the optimal event-triggered controller by common approaches. Comments on limitations and extensions show that the obtained result is also valid in the presence of noisy measurements and certain types of communication models.

REFERENCES

- [1] K. J. Åström and B. M. Bernhardsson, "Comparison of Riemann and Lebesgue sampling for first order stochastic systems," in *Decision and Control, 2002, Proceedings of the 41st IEEE Conference on*, vol. 2, Dec. 2002, pp. 2011–2016.
- [2] A. Cervin and T. Henningson, "Scheduling of event-triggered controllers on a shared network," in *Decision and Control, 2008, Proceedings of the 47th IEEE Conference on*, Dec. 2009, pp. 3601–3606.
- [3] D. V. Dimarogonas and K. H. Johansson, "Event-triggered control for multi-agent systems," in *Decision and Control, 2009, Proceedings of the 48th IEEE Conference on*, Dec. 2010, pp. 7131–7136.
- [4] P. Wan and M. Lemmon, "An event-triggered distributed primal-dual algorithm for network utility maximization," in *Decision and Control, 2009, Proceedings of the 48th IEEE Conference on*, Dec. 2009, pp. 5863–5868.
- [5] P. Tabuada, "Event-triggered real-time scheduling of stabilizing control tasks," *Automatic Control, IEEE Transactions on*, vol. 52, no. 9, pp. 1680–1685, 2007.
- [6] M. Rabi, K. H. Johansson, and M. Johansson, "Optimal stopping for event-triggered sensing and actuation," in *Decision and Control, 2008, Proceedings of the 47th IEEE Conference on*, Dec. 2008, pp. 3607–3612.

- [7] O. Imer and T. C. Basar, "Optimal control with limited controls," in *American Control Conference, 2006*, Jun. 2006, pp. 298–303.
- [8] L. Meier III, J. Peschon, and R. Dressler, "Optimal control of measurement subsystems," *Automatic Control, IEEE Transactions on*, vol. 12, no. 5, pp. 528 – 536, Oct. 1967.
- [9] W. Wu and A. Arapostathis, "Optimal sensor querying: General markovian and LQG models with controlled observations," *Automatic Control, IEEE Transactions on*, vol. 53, no. 6, pp. 1392 –1405, Jul. 2008.
- [10] V. S. Borkar and S. Mitter, "LQG control with communication constraints," *Communications, Computation, Control, and Signal Processing: A Tribute to Thomas Kailath*, pp. 365–373, 1997.
- [11] S. Tatikonda, A. Sahai, and S. Mitter, "Stochastic linear control over a communication channel," *Automatic Control, IEEE Transactions on*, vol. 49, no. 9, pp. 1549–1561, Sep. 2004.
- [12] G. Nair, F. Fagnani, S. Zampieri, and R. Evans, "Feedback control under data rate constraints: an overview," *Proceedings of the IEEE*, vol. 95, no. 1, pp. 108–137, 2007.
- [13] Y. Xu and J. Hespanha, "Optimal communication logics in networked control systems," in *Decision and Control, 2004, Proceedings of the 43rd IEEE Conference on*, Dec. 2004, pp. 3527–3532.
- [14] H. Witsenhausen, "Separation of estimation and control for discrete time systems," *Proceedings of the IEEE*, vol. 59, no. 11, pp. 1557–1566, 1971.
- [15] A. Molin and S. Hirche, "On LQG joint optimal scheduling and control under communication constraints," in *Decision and Control, 2009, Proceedings of the 48th IEEE Conference on*, Shanghai, China, Dec. 2009, pp. 5832–5838.
- [16] H. S. Witsenhausen, "A standard form for sequential stochastic control," *Theory of Computing Systems*, vol. 7, pp. 5–11, 1973.
- [17] S. Boyd and L. Vandenberghe, *Convex optimization*. Cambridge Univ. Press, 2004.
- [18] H. S. Witsenhausen, "A counterexample in stochastic optimum control," *SIAM Journal on Control*, vol. 6, no. 1, pp. 131–147, 1968.
- [19] D. P. Bertsekas, *Dynamic programming and optimal control. Vol. I*. 3rd ed., Athena Scientific, Belmont, MA, 2005.
- [20] K. J. Åström, *Introduction to stochastic control theory*. Dover Publications, 2006.
- [21] G. Lipsa and N. Martins, "Remote state estimation with communication costs for first-order LTI systems," *Automatic Control, IEEE Transactions on*, vol. 56, no. 9, pp. 2013–2025, 2011.
- [22] M. Rabi, G. V. Moustakides, and J. S. Baras, "Adaptive sampling for linear state estimation," *SIAM Journal on Control and Optimization*, vol. 50, no. 2, pp. 672–702, 2012.
- [23] O. C. Imer and T. Basar, "Optimal estimation with limited measurements," *Int. J. Systems, Control and Communications*, vol. 2, nos. 1/2/3, pp. 5–29, Jan. 2010.
- [24] E. Altman, *Constrained Markov decision processes*. CRC Press, 1999, vol. 7.
- [25] A. Molin and S. Hirche, "Structural characterization of optimal event-based controllers for linear stochastic systems," in *Decision and Control, 2010, Proceedings of the 49th IEEE Conference on*, Atlanta, USA, Dec. 2010, pp. 3227–3233.
- [26] C. Ramesh, H. Sandberg, and K. H. Johansson, "LQG and medium access control," in *1st IFAC Workshop on Estimation and Control of Networked Systems*, Sep. 2009, pp. 328–333.
- [27] A. Molin and S. Hirche, "Suboptimal event-based control of linear systems over lossy channels," in *2nd IFAC Workshop on Estimation and Control of Networked Systems*, Sep. 2010, pp. 55–60.