

FIRE SAFE SERVICE INSTALLATIONS IN TIMBER BUILDINGS

Norman Werther¹, Michael Merk², René Stein³, Stefan Winter⁴,

ABSTRACT: In recent years residential buildings have been increasingly equipped by technological devices and service supplies to gain an appropriate standard of comfort. Despite these service installations and associated penetrations the fire resistance of fire separating elements must not be negatively influenced. There are currently no approved systems or recommendations for fire safe penetration sealing products in separating timber elements available. However new measures and recommendations for fire safe service installations in timber structures can be derived from numerical simulations and fire tests conducted in a European research project and further work of the authors.

KEYWORDS: Fire exposure, Service installations, Penetration sealing, Timber buildings

1 INTRODUCTION

In recent years the increasing demand for new, innovative, energy and cost efficient buildings is noticeable all over the world. This is especially true for residential, office and administration buildings as well for wide span structures in combination with timber as a building material. There are many benefits to building timber structures, such as visual and tactile attractiveness, high energy efficiency, quick erection time and a low carbon footprint. However the greatest concerns by authorities over the use of timber as a building material in modern buildings are normally related to the fire safety. These concerns (influence of combustibility, contribution to flame spread ...) usually are not appropriately addressed by design codes and this can lead to limitations for the use of timber in many countries.

In the event of fire the separating function for wall and floor elements represents one of the most essential capacities, besides the structural stability. The building occupants and fire service therefore must have confidence in the correct performance and function of these elements.

The evaluation of fire resistance for such assemblies normally occurs on the basis of standardised fire tests, such as cited in EN 13501-2 [3] and ASTM E 119 [4], as well as approved calculation methods, such as those presented in EC 5-1-2 [2].

These methods don't normally take in to account any junction to neighbouring elements, mounting parts or penetrations of service installations. However, these service installations are necessary and essential for the use of a building.

To prevent fire spread for all building materials and construction methods, certified sealing systems and compounds are required, which have the same fire resistance time as the separating building elements, to avoid early spread of fire and early ignition of materials inside the elements.

1.1 FLAME SPREAD PATHES

Typically buildings are divided into compartments (firecells), surrounded by separating barriers like walls, floor and ceilings that have a fire resistance and prevent the spread of fire. By standards and building codes the spread of fire between fire cells is assumed by structural failure of members (R), exceed of a critical temperature on unexposed side (I) and the loss of integrity in the envelop (E) in accordance with the failure criteria in EN 13501-2 [3].

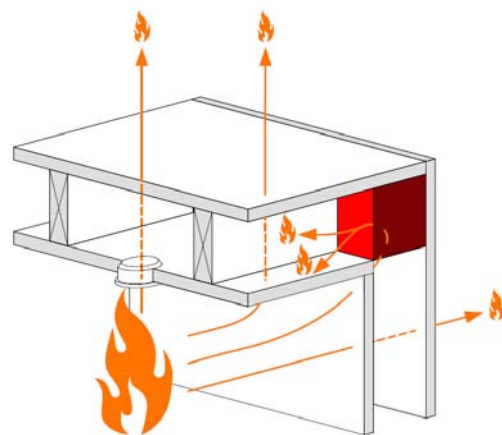

Figure 1: illustration of typical fire spread paths in building elements

¹ Norman Werther, Research Associate, Email: werther@bv.tum.de

² Michael Merk, Research Associate, Email: merk@bv.tum.de

³ René Stein, Research Associate, Email: stein@bv.tum.de

⁴ Stefan Winter, Professor, Email: winter@bv.tum.de
Technische Universität München, Chair for Timber Structures and Building Construction, Arcisstraße 21, D-80333 München.

At the same time a review of fire scenarios and full scale fire test in recent years shows that for all building materials and construction methods the reason for early fire spread from one fire cell to the next is mainly caused by blocked doors or open windows and especially by

inappropriately designed or installed service installations, connections and joints (paths depicted in Figure 1). At the same time a survey found that 50% of the services were not installed properly and would not be able to perform well in the case of fire.

1.2 TYPES OF SERVICE INSTALLATIONS

To ensure the currently required level of comfort in our buildings technical devices and service installations become necessary. Hence installations such as electrical and communication wiring, heating systems, water and sewage pipes as well as wall sockets and switches are already integrated in the planning phase of the building. Approximately 10 % of the overall costs are attributed to these installations in multi-storeyed building.

Several fire tests and technical approvals show that every type of building services installation passing through fire separating elements has its own specific characteristic, level of performance and therefore range of application. Hence there is no single solution or product that will be used for all services and protect all elements in the same manner to avoid early fire spread.

For the selection and arrangement of an adequate penetration sealing system the services must be classified under consideration of number, size, material of the supply lines and transported substances. Thus the service installations and sealing systems can be distinguished as follows.

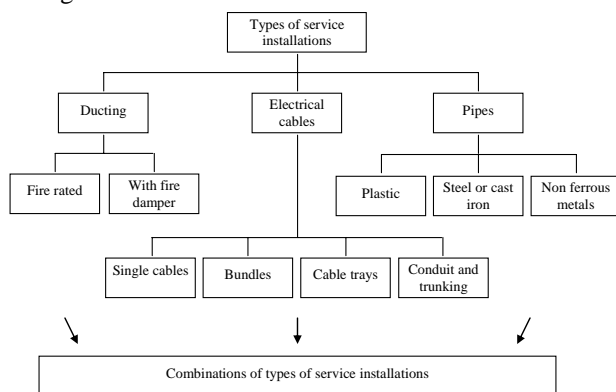

Figure 2: types of service installations

2 ARRANGEMENT CONCEPTS AND STANDARDS

2.1 ARRANGEMENT OF SERVICE INSTALLATIONS

Penetrations of building services through separating building elements are unavoidable, and must be planned and allowed for from the beginning of a project. This helps to avoid unnecessary penetrations and complex solutions in the latter stages of construction. Therefore it should be aimed to include all service installations to previously defined fire compartments. This can be done by the application of following design concepts:

- central distribution of all service lines in fire rated service shafts and ducts with appropriate sealing of the penetrated areas

- penetration sealing in each separating element (wall, floor) with approved sealing compounds and systems
- continuous encasing of each service line throughout its entire length by coatings, wrappings or linings

All of these solutions must not only satisfy the requirements for fire safety but also the requirements for acoustic, moisture and thermal performance. Furthermore, the accessibility for revision, maintenance and additional installations should be allowed for.

Based on these considerations and taking into account further aspects, such as practical execution on site and durability the solution of a service shaft in combination with timber structures shows some disadvantages. Most notably the problems of airborne sound transmission between compartments through service shafts or ducts, cracks caused by different settlement and different moisture movement of service shafts and remaining building structure, and the necessity to seal each penetration through the shaft and finally the high costs can be mentioned. Therefore designs of sealing the penetration of service installations in each separating element may be recommended for timber structures.

2.2 STATE OF THE ART

Until now, fire tests of penetration sealing systems and sealing compounds for penetrations in timber frame and solid timber constructions are missing and acceptable solutions are rare. Approved sealing systems are typically only available for concrete or drywall construction at the moment. Further recommendations and acceptable solutions for these structures, based on fire test are made in the literature all over the world [5], [6].

Penetrations of service installations in timber assemblies are mainly for single cables, cable bundles, heating, fresh water pipes and sewage pipes. In combination with timber structures, the following weak points can be identified:

- Service installations made from combustible materials and materials that melt at fairly low temperatures, such as wirings or plastic pipes, may lead in combination with wood based panels to a quick formation of gaps or holes in the penetration area during a fire and increase the fire spread.
- Metal pipework can increase the heat flow through the assembly, thus an early flame spread to the unexposed side or inside the assembly may be possible.
- The application of penetration sealing systems, such as coated mineral wool boards, usually reduces the cross section of the timber structures (see Figure 12 and Figure 17). Gaps and the unprotected reveal area may lead to an early fire spread to the inside cavity of the timber assembly and a sideways passing of the penetration sealing system.

To check the applicability of existing penetration sealing systems and sealing compounds for timber structures, as well as develop further design rules, numerous fire tests were carried out. The following investigations took into

account the sealing for penetrations of electrical wirings, the development of equivalent installation conditions in timber structures for already approved penetration sealing systems as well as the fire safe installation of wall sockets and switches in timber frame and solid timber structures.

3 CONCEPT AND EXPERIMENTAL INVESTIGATION

3.1 CONCEPT AND BASICS OF RATING

The concept in these investigations focussed on modifying existing and approved sealing systems for safe use in timber structures. The series of experiments have been split in to three parts.

In the first part, different types of penetration sealing compounds for electrical wiring, in combination with wood based panels and solid timber elements were assessed. In this step common sealing compounds have been used.

As timber framed and lined assemblies and non-combustible drywall constructions have similar failure mechanisms when exposed to fire (for example, attrition and the collapse of the lining) the main focus in this study was laid on the modification of existing and already approved penetration sealing systems for drywall constructions, to achieve fire safety in combination with timber structures too. Special attention was paid to the development of measures to line and frame, the reveal area (see Figure 17) to get similar boundary and installation conditions for all sealing systems. Finite Element (FE) simulations and small scale tests to determine the thickness of lining and the influence of fasteners were used to aid the design of the conducted fire test.

The third step in this investigation considered the fire safe design of wall sockets and switches in separating timber elements.

A special focus in all investigations was to develop a fire-safe, durable and fail-safe design, with a high acceptability in practice, in the implementation of joints and junctions in a separating element and sealing systems.

3.2 TEST SETUPS

Penetration sealing compounds

For the assessments of a fire safe sealing of electrical wirings in combination with wood based panels five small scale fire tests were conducted. The assemblies were made of OSB with dimensions of $W \times H = 540 \text{ mm} \times 540 \text{ mm}$ and thickness of 15 mm and 25 mm respectively. One 15 mm thick panel was additionally lined with 9.5 mm thick gypsum plasterboard. The bulk density of the panels was $\sim 580 \text{ kg/m}^3$ and moisture content $\sim 7 \%$. All panels were screwed to a wooden frame to ensure more stability in the fire tests and the mounting at the furnace. The single electrical cables or cable bundles applied in these tests are specific for electrical wiring in building structures. Normally these consist of 3 respectively 5 PVC insulated copper conductors with a further outer PVC sheathing

and can be classified according to DIN VDE 0250. All electrical cables were supported on the unexposed side, to ensure practical conditions. In this step of investigations gypsum putty, mineral fibre insulation plugs, fire retardant foams and mastics as well as intumescent wraps and sealing compounds were used to seal the penetration area.

The tests were carried out under variation of panel thickness, type of sealing, size of annular gap (0 - 10 mm) and number of electrical wiring per penetration. In each test four different sealing setups were assessed (see Figure 3).

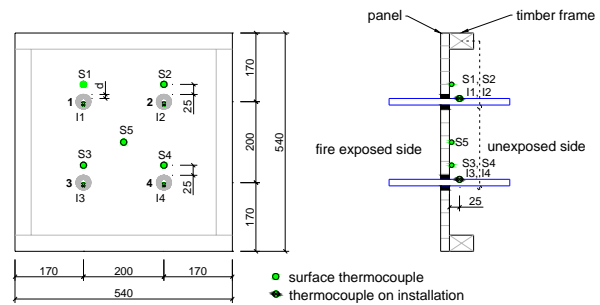

Figure 3: setup fire tests for sealing compounds

The temperature formation on unexposed side was measured with type K thermocouples at each cable and 25 mm beside the penetration area as well as in the centre of the OSB panel (see Figure 3), to compare the failure times at penetrations and the plane undisturbed panel to each other.

Penetration sealing systems

To assess the applicability of drywall constructions approved sealing systems four small scale tests for timber frame and solid timber assemblies were conducted by TU Munich and two full scale tests for timber frame assemblies by the German Society for Wood Research (DGfH e.V.).

The tests included sealing systems for plastic pipes up to 160 mm in diameter, for copper and steel pipes, for various cables and cable bundles as well as measures for multiple penetrations of cables and pipes. In the small scale tests assembly dimensions of $W \times H = 1180 \text{ mm} \times 1180 \text{ mm}$ were used. The first timber frame wall was designed for a fire resistance of 30 minutes, the second and the solid timber assemblies for a fire resistance of 90 minutes each. The cavities of the timber frame walls were filled with flexible wood fibre insulation. The design and cross section of the timber frame constructions can be taken from Figure 4. For the fire tests of solid timber elements, cross laminated timber panels (CLT) with thickness of 120 mm were used, consisting of 5 single layers each and bonded together with melamine resin. These panels had no additional lining at exposed and unexposed side.

In contrast to the timber frame elements an additional multi penetration sealing system was considered in the two CLT panels, to assess the performance of the framed and lined reveal area. The used sealing system was made up of an 80 mm thick mineral wool board and coated

with an intumescent painting. The board was fitted tightly in the previous with fire rated gypsum plasterboards lined opening in each test. Gaps between the mineral wool board and plasterboard lining were filled by an intumescent painting at each side according to the technical approval of the system.

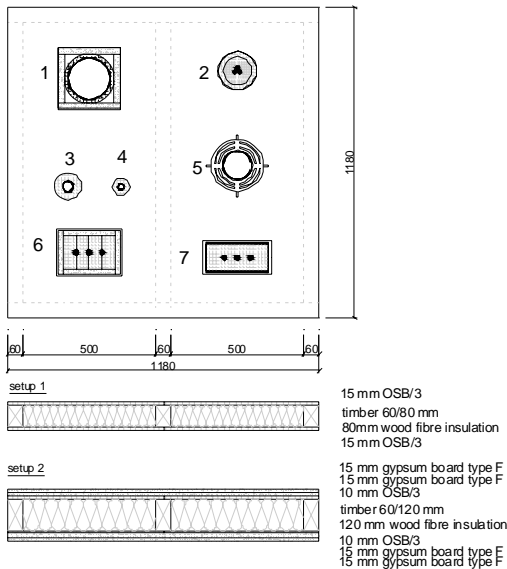

Figure 4: setup of timber frame assemblies with penetration sealing systems

In the small scale fire tests each penetration sealing was equipped with several type K thermocouples in accordance with EN 1366-3 to measure the temperature formation inside the assemblies, at the unexposed side and in the penetration area (example depicted in Figure 5) as well as to compare these results to the standard benchmarks.

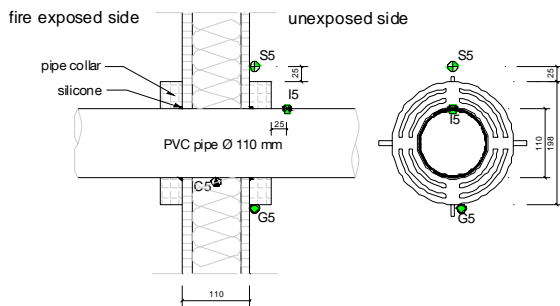

Figure 5: arrangement of thermocouples in each penetration area (example shown for a pipe collar)

To ensure appropriate fire safety in the reveal area for multi penetration sealing systems, such as mineral wool boards, the required thickness of the attached lining has been determined approximately by numerical simulation in advance. Different dimensions of plasterboard linings (2 x 10 mm up to 2 x 18 mm) for the reveal area in combination with a 100 mm wide framed lining around the surface were investigated with respect to heat flow and protection capacity for the timber located behind. The Points “A” - directly in the corner and “I” - 35 mm

above the corner were used for these assessments (see Figure 12). The additional influence of joints in the gypsum plasterboards and between timber member and reveal lining were not investigated in this manner.

In the numerical simulations, the lined corners of the reveal areas (see Figure 12) were impinged with the standard fire curve of ISO 834 [7] over 30, 60 and 90 minutes respectively. For the FE analyses the material properties of Eurocode 5-1-2 [2] for timber and published literature values [8] for gypsum plaster boards were taken. Furthermore the boundary conditions of Eurocode 1-1-2 [1] were applied.

In addition, two full scale fire tests with a timber frame wall and floor assembly in combination with a mineral wool board multi penetration sealing system and installed services were conducted [9], [10]. Before lining the reveal areas a support infill frame was attached in the opening of the timber frame wall and floor, to stabilise and support the gypsum plasterboard cladding. For these fire tests two layers of 18 mm gypsum plasterboards were used to line the reveal area. The wall and floor assembly were also lined in the entire exposed surface with the same plasterboards.



Figure 6: full scale fire tests of wall assembly with multi penetration sealing systems after fire test (picture DGFH)

These full scale fire tests were carried out in accordance with EN 1366-3 and under ISO 834 fire curve exposure. The failure criteria in all tests were measured in terms of:

- integrity (E) considering ignition of cotton pad and flame ejection on unexposed surface and
- insulation (I) with temperature increase less than 180°C above the initial ambient temperature.

Stability or structural adequacy was not recorded for these tests and so no additional load was applied.

Socket and switches

The influence of installation conditions for switches and sockets in timber frame and solid timber constructions has been assessed on base of several existing standard fire test for wall elements (see Figure 7). Thus four different systems - fire prevention insulation layer, gypsum putty, gypsum plasterboard boxes, and intumescent device shells were considered.

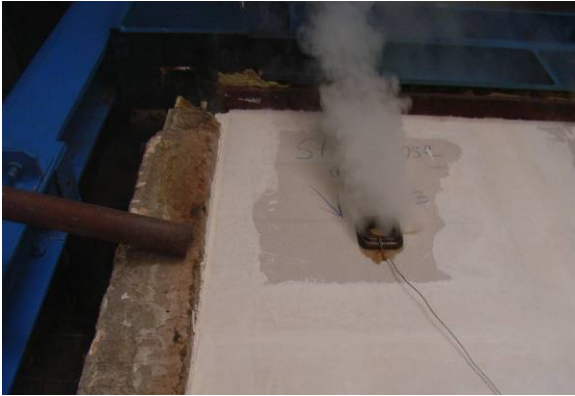

Figure 7: standard fire tests for a wall assembly under consideration of socket

4 EXPERIMENTAL RESULTS

4.1 SEALING FOR ELECTRICAL WIRING

Due to the large number of examined setups [12] only general results will be shown in this paragraph. Derived recommendations will be presented in paragraph 5. Several of the examined approved sealing compounds showed excellent results in combination with cable penetrations in OSB panels and solid timber, in respect of equal failure times in the penetrated and un-penetrated areas.

All conducted tests showed larger heat transfer through the cables itself in comparison to the plane panels and sealing compounds. As expected, an increase in the number and conductor diameter led to an increase of heat transfer throughout the cables and faster temperature formation in the penetration area. For one cable bundle an early ignition at unexposed side of the OSB lining occurred (see Figure 8).



Figure 8: ignition at unexposed side

All test results showed an influence of the annular gap size and the used sealing compounds for the temperature formation at OSB lining in the penetration areas. The tight executed cable penetration, without annular gap, showed a self sealing effect in the penetration area, due to the thermal expansion of the outer PVC sheathing. However this execution caused slightly higher temperatures in the penetration area compared to

penetrations with a sealed annular gap. For the examined penetration sealings of electrical wirings with an annular gap sizes between 5 and 10 mm a formation of joints was obvious between the lining and the sealing material in all fire tests. Those gaps increased by time of exposure and were more distinctive for “passive” sealing compounds, such as uncompressed mineral wool plugs. Better results were reached by the use of flexible sealing compounds or by the use of gypsum putty. Flexible sealing compounds, such as intumescent mastics showed additional benefits in the tests by reducing the smoke passing the penetration area.

4.2 PENETRATION SEALING SYSTEMS

4.2.1 Single Systems

As for the sealing compounds excellent results have also been reached for approved penetration sealing systems in timber structures [11], [13]. Therefore equal failure times for the plane timber elements and penetration areas have been guaranteed (see Figure 9).



Figure 9: failure of small scale timber frame assembly (EI 30) after 43 minutes

As the most critical area for an early failure, the junction of penetration sealing system and timber element was found in all tests. This has been caused by problems to fill the joints in the entire depth of the lining (see Figure 10).



Figure 10: failure in sealed penetration junction (left); insufficient sealing with gypsum putty (right)

This problem was more significant for multilayer and thick linings in combination with gypsum putty or mastics when compared with intumescent sealing compounds. Here gaps and small voids in the sealed joints were subsequently closed by thermal expansion of the intumescent material.

An almost smoke tight penetration for plastic pipes in combination with pipe collars and for metal pipes in combination with mineral wool pipe linings was reached by an additional circular silicone sealing with silicone (see Figure 5 and Figure 11).

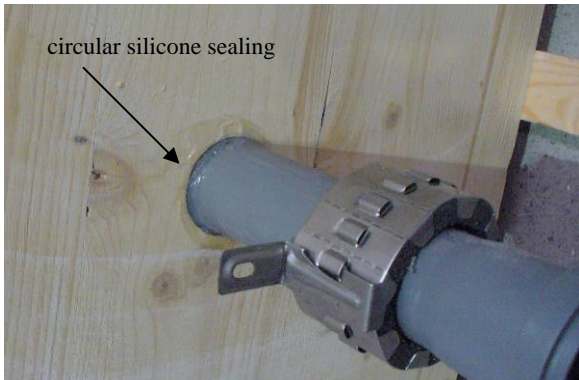

Figure 11: further smoke proof sealing

4.2.2 Reveal Lining For Multi Systems

For designing the setup of fire tests numerical simulations were conducted to determine approximately the required thickness of gypsum plasterboard cladding in the reveal area for various fire resistances.

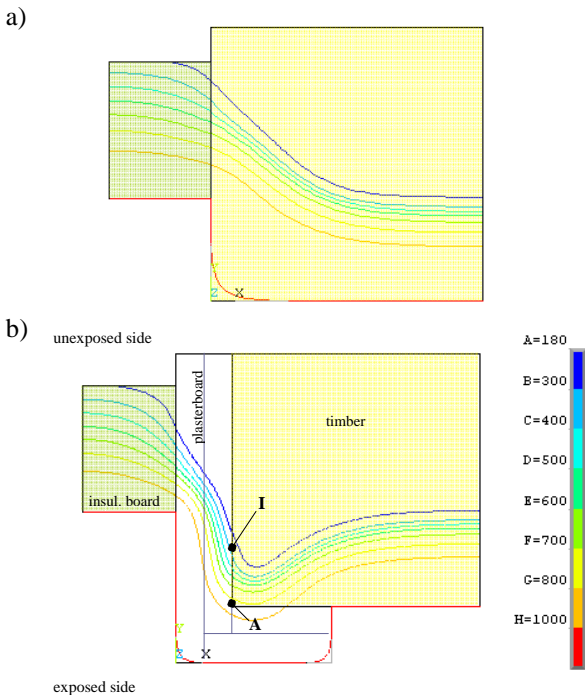

Figure 12: assembly setup for num. simulation with isotherms after 90 minutes for (cross section)
a) without reveal lining
b) 2 x 18 mm gypsum plasterboard lining and framing

Under consideration of a critical temperature of 300°C (in accordance with EC 5-1-2) the protection capacity of lining was determined for point “A” and “I”. In the numerical simulations the 2D heat transfer influence became apparent for the corner and resulting in a faster temperature rise as for point “I”. For this point, with less thermal exposure no exceed of critical temperatures were detected under consideration of following lining dimensions:

- $\geq 2 \times 10$ mm for 30 minutes,
- ≥ 12.5 mm x 15 mm for 60 minutes and
- $\geq 2 \times 18$ mm for 90 minutes.

Due to these results the setups for the fire tests were derived. The thermal degradation of the timber members was accepted in the area of exposed corner. In this manner designed and conducted reveal areas showed excellent performance under fire exposure in combination with the 100 mm wide framed lining.



Figure 13: fire test at CLT element with lined and framed reveal area

4.2.3 Further Observations

During the tests with CLT elements flame spread alongside inner gaps took place and finally reached the unexposed side in the wall-floor junction (see Figure 14). These gaps in the CLT elements are typical and are caused by a lack of bonding of the inner layers at the narrow sides.



Figure 14: flame spread caused by gaps in CLT elements

5 DERIVED RECOMMENDATION

5.1 PENETRATIONS OF CABLES

The results obtained in this study show the necessity of a proper sealing for electrical wirings in the penetration area to reach fire safety in combination with timber frame- and solid timber structures. As timber frame and drywall structures have similar failure mechanisms and material behaviour of the lining when exposed to fire, many approved sealing measures for drywall structures are appropriate for timber constructions too and should be used as presented in (Table 1). Special attention must be paid to the gapless and void free sealing of the 5 – 10 mm wide annular gap in complete thickness in the penetrated lining on both sides of the elements. For solid timber elements a sealing depth of at least 40 mm on both sides is recommended to reach a fire resistance time up to 90 minutes. In the case of an annular gap less than 0.5 mm, no additional sealing is needed for skinny cables.

For thicker cables and cable bundles the conducted heat through the penetration increases and only highly efficient and durable measures or special penetration sealing systems shall be used. The individual measures can be taken from Table 1 and clause 5.2.

In addition the following conditions must be observed:

- distance d between adjacent cable penetrations \geq largest hole diameter (see Figure 15)
- density of penetrated wooden panel $\geq 400 \text{ kg/m}^3$ reaction to fire class at least D s2 d0 (EN 13501-1)
- for smoke proof connections at service installations use of permanent elastic sealing compounds or mastics

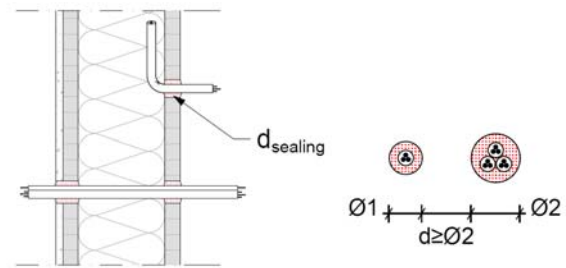

Figure 15: penetration sealing for electrical wirings

For variations in design and execution of construction work the application of approved penetration sealing systems becomes necessary, as presented in following clause 5.2.

5.2 PENETRATION SEALING SYSTEMS

5.2.1 Single Systems

The assessed systems contained combustible and non-combustible service pipes in addition to penetrations of cable bundles. It is found that systems with intumescent materials (“active systems”), which expand when exposed to high temperatures, efficiently seal the gap between the sealing system and lining of the timber frame or solid timber elements. For systems with “passive” sealing materials, such as gypsum putty, the fully gapless filling throughout the complete depth of the lining is needed also. For thick linings of separating timber frame elements the application of a consistent sealing becomes difficult and requires a technical and material specific high demand. To optimize these joints for fire conditions an additional 100 mm wide and minimum 12.5 mm thick non-combustible framed lining is strongly recommended (see Figure 16).

Table 1: sealing measures for electrical wirings

Sealing measure	Annular gap size	Type of electrical cable		
		Single electrical cable	Cable bundle ²⁾	
			NYM ¹⁾ $\leq 5 \times 16 \text{ mm}^2$	≤ 3 cables $1 \times \text{NYM} \leq (5 \times 16 \text{ mm}^2) +$ $2 \times \text{NYM} \leq (3 \times 2,5 \text{ mm}^2)$
- no further sealing	$\leq 0,5 \text{ mm}$	■		
- gypsum putty	5 to 10 mm	■	■	■
- intumescent wrappings, - sealing compounds or mastics, - fire retard. polyurethane foam (with technical approval)		■	■	■
- stone wool plugs, density $\geq 70 \text{ kg/m}^3$		■	■	

1) cable NYM Y x Z mm²: Y PVC insulated copper conductors with a further outer PVC sheathing, cross section of conductors Z mm² each (in accordance with DIN VDE 0250)

2) for combustible cavity insulation use of non-combustible stone wool pipe lining insulation around the cables

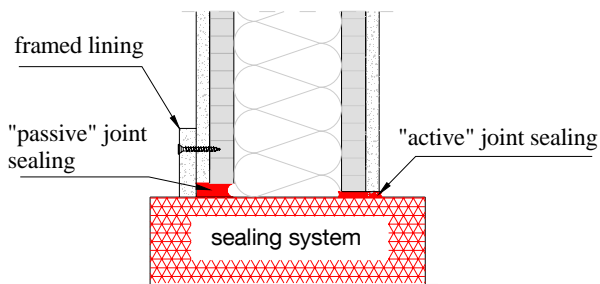

Figure 16: joint sealing for penetration sealing system

5.2.2 Multi Systems

For installation of multi penetration sealing systems in compartment timber structures comparable conditions to those used in concrete or drywall constructions must exist. Through this the fire spread inside the timber structure and sidewise passing of the sealing system can be excluded.

The main concept is to line the reveal area of the penetrations / openings with a non-combustible encasing cladding, such as gypsum plaster - or gypsum fibre boards over the entire thickness of the separating element, including the attachment of an additional framed lining of at least 100 mm wide around both sides of the surface. This is to create joint steps and avoid continuous joints for convective heat flow through the structure and between reveal lining and structural timber element. For the setup of reveal linings two layers are preferable (Figure 17). In addition for timber frame constructions a support infill frame with at least 40 mm in the opening area is necessary to stabilise and support the reveal cladding and the framed lining.

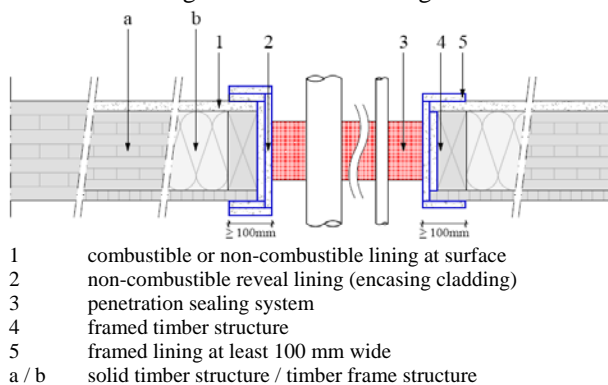

Figure 17: fire safe lining of reveal area for installation of penetration sealing system (mineral wool board)

5.3 SWITCHES AND SOCKETS

To ensure the fire safety of separating elements in the areas of switches and sockets, the following measures are recommended and shall be used in practical application [14].

- A) gypsum putty: thickness of surrounding gypsum putty at least 30 mm, only in combination with full insulated cavities

- B) gypsum plaster board box: fire retardant boards with thickness of at least 15 mm
- C) intumescent device casing: necessity of technical approval
- D) fire prevention insulation layer: at least 150 mm wide high temperature suitable mineral wool to each side of socket or inner encasing cladding for timber members

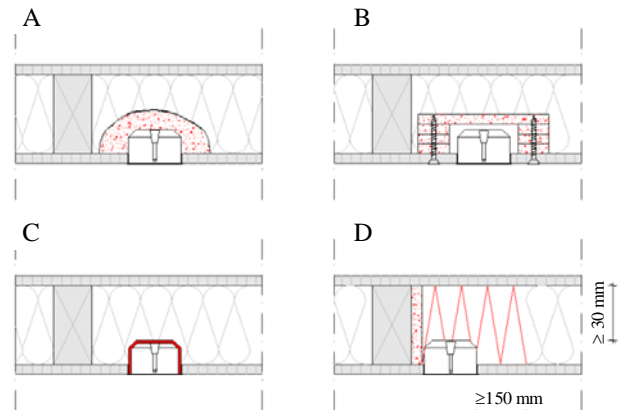

In alternative to these sealing measures the arrangement of an installation gap in front of the existing timber structure is recommended. This eliminates the negative influence of unsealed or inappropriate sealed penetrations for sockets and switches and ensures the fire safety of the separating elements.

6 CONCLUSIONS

The investigations show that the selected approved penetration sealings and systems for separating timber elements are applicable in accordance with the specified design restrictions and no early failure of the service penetration will occur in the case of fire. The lining of the reveal area represents an efficient fire safety concept that provides for multiplicity of existing penetration sealing systems similar and fire safe installation conditions.

National and international knowledge as well the executed fire tests show that existing penetration sealing systems can be used in combination with timber structures to assure fire safety.

ACKNOWLEDGEMENT

The authors wish to acknowledge all partners and colleagues in WoodWisdom-Net project "FireIn Timber" for lively discussions and matching of design details. The German part of the WoodWisdom-Net program was coordinated by Projektträger Jülich and financed with funds of Federal Ministry of Education and Research (BMBF).

REFERENCES

- [1] European Committee for Standardisation (CEN). Eurocode 1. Actions on structures. Part 1-2: General actions – Actions on structures exposed to fire; EN 1991-1-2. Brussels, Belgium, 2003.

- [2] European Committee for Standardisation (CEN). Eurocode 5. Design of timber structures. Part 1-2: General – Structural fire design; EN 1995-1-2. Brussels, Belgium, 2004.
- [3] European Committee for Standardisation (CEN). EN 13501-2. Fire classification of construction products and building elements - Part 2: Classification using data from fire resistance tests, excluding ventilation services; EN 13501-2:2007+A1:2009,
- [4] American Society for Testing and Materials, ASTM E 119. Fire tests of building construction and materials
- [5] England J.P., Young S.A., Hui M.C. and Kurban N.: Guide for the Design of Fire Resistant Barriers and Structures. Building Control Commission Melbourne Australia, 2000
- [6] Fachkommission Bauaufsicht der Bauministerkonferenz: Muster-Richtlinie über brandschutztechnische Anforderungen an Leitungsanlagen (Muster-Leitungsanlagen-Richtlinie MLAR) 2005
- [7] International Organization for Standardization (ISO). ISO 834-1 Fire-resistance tests - Elements of building construction - Part 1: General requirements; 1999-09
- [8] Schleifer, V.: Zum Verhalten von raumabschließenden mehrschichtigen Holzbauteilen im Brandfall, PhD thesis; ETH Zürich 2009.
- [9] MPA Braunschweig: Prüfbericht (3049/9435)-13-TP, Prüfung einer etwa 285 mm dicken, raumabschließenden, wärmedämmenden Deckenkonstruktion mit einer unterseitigen „K260 Brandschutzbekleidung“ aus 2 x 18 mm dicken Gipskartonfeuerschutzplatten (GKF) zum baupraktischen Nachweis des „Kapselkriteriums“ in Verbindung mit Durchführungen von Kabeln und Rohren bei Brandbeanspruchung von der Deckenunterseite; 25.08.2006
- [10] MPA Braunschweig: Prüfbericht (3049/9435)-7-TP, Prüfung einer etwa 162 mm dicken, raumabschließenden Holzständerwand mit beidseitiger „K260 Brandschutzbekleidung“ aus 2 x 18 mm dicken Gipskartonfeuerschutzplatten (GKF) zum baupraktischen Nachweis des „Kapselkriteriums“ in Verbindung mit Durchführungen von Kabeln und Rohren bei Brandbeanspruchung von der Deckenunterseite; 17.03.2006
- [11] Werther, N.: test results Nr. 09-001, small scale fire tests for classified penetration seals and systems in combination with timber frame construction; Technische Universität München - chair of timber structures and Building construction, 2009
- [12] Werther, N.: test results Nr. 09-002, small scale fire tests for sealing systems for cables in combination with timber frame constructions; Technische Universität München - chair of timber structures and building construction, 2009
- [13] Werther, N.: test results Nr. 10-001 and Nr. 10-002, small scale fire tests for lined cross laminated timber (CLT) wall and floor elements in combination with classified penetration sealing systems (test 1 wall penetrations) (test 2 floor penetrations); Technische Universität München - chair of timber structures and building construction, 2012
- [14] Östman B., Mikkola E., Stein R.: Fire safety in timber buildings, Technical guideline, SP-Report 2010:19