

FEATURES AND CHARACTERISTICS OF LOW-GRADE HEAT STORAGE FOR ORGANIC RANKINE CYCLE

Sindu Daniarta^{1,2,*}, Piotr Kolasinski¹

¹Wrocław University of Science and Technology, Department of Thermodynamics and Renewable Energy Sources, Wrocław, Poland

²Budapest University of Technology and Economics, Department of Energy Engineering, Budapest, Hungary

*Corresponding Author: sindu.daniarta@pwr.edu.pl

ABSTRACT

Nowadays, different waste heat sources from industrial processes, renewables, and other heat sources of low thermal potential (e.g., ocean thermal energy) are considered to be utilized in power generation. In the manufacturing process, the waste heat is likely low temperature and to exploit it, the installation of the heat storage systems tends to be necessary. Not only hot sources, but the waste heat may also refer to the potential of cold sources. Organic Rankine Cycle (ORC) systems employing the volumetric expanders (e.g., screw, multi-vane, scroll, and piston expanders) as prime movers appear to be one of the suitable technologies that could be integrated with heat storage systems and applied for power generation. Literature reviews show that heat storage has been practically implemented in the process of liquefied natural gas (LNG) in a regasification system. Also, there are several concepts of possible configurations of heat storage devices. However, there is a lack of experimental and modelling research concerning this heat storage system applied in low-grade energy ORC. In this paper, the discussion of modelling and analysing heat storage devices combined with ORC is reported. Obtained modelling results show that a hot storage evaporator (HSE) and a cold storage condenser (CSC) as the integration of heat storage devices in ORC systems seems to be a promising solution to utilize low-temperature heat sources because they could serve both as heat storages and heat source characteristic regulators. Since the advantages of its function, the modelling of ORC system operating conditions for different types of heat storage devices was carried out. The result shows that scenario keeping stability in the operating temperature range of the ORC system is essential concerning the charging and discharging times that has to be taken into consideration in the main design stage before fabricating HSE and CSC.

1 INTRODUCTION

Organic Rankine Cycle (ORC) is a thermodynamic Rankine cycle using organic materials instead of water as a working fluid. This technology is an excellent option to be implemented to recover energy from industrial waste heat, low temperature geothermal, ocean thermal power, biomass, solar thermal, etc. Many researchers investigated the utilization of the low-grade energy exploiting ORC system as power generation employing volumetric expanders (e.g., screw, multi-vane, scroll, and piston machines) (Badr *et al.*, 1984; Dumont *et al.*, 2018; Kolasinski *et al.*, 2016; Smith *et al.*, 2014). It is found that sometimes the hot or cold sources are intermittent and floating depending on the time and the weather.

For example, the thermal energy collected from solar radiation with concentrated solar power (CSP) works in limited operating time and depends on the weather (Pelay *et al.*, 2017), similarly to an intermittent heating system of a residence (Wang *et al.*, 2015) and waste heat recovery from industrial process (Pantaleo *et al.*, 2018), etc. This phenomenon is one of the issues faced in the case of harvesting low-energy. The unwanted change of temperature of heat sources will significantly affect heat transfer between heat sources and the cycle, which leads to unsuccessful or partial evaporation of the working

fluid. For this reason, thermal energy storage (TES) is one of the possible technologies to be installed in the process aiming to store the thermal heat and regulate the mass flow rate.

There are many suitable types of TES (i.e., sensible heat, latent heat, and chemical reactions). TES could also be classified by the type of energy storage material (Zalba *et al.*, 2003). Also, thanks to the possibility of cold thermal energy storage (CTES) it could be effectively used to keep LNG in liquified form for distribution (Oró *et al.*, 2012). Many researchers have been investigating different types of TES and its application methods; Chacartegui *et al.* (2016) analyzed the possibility of application of two TES in the integrated system of ORC and solar collector; Freeman *et al.* (2017) investigated the combined heat and power (CHP) system with TES; Kolasiński (2020) carried out experimental and modelling research on the possibility of application of heat storage in ORCs. Also, literature reviews show that many researchers focus on the type and potential of a combination of TES with a power generation system, the type of insulation, and type of materials (Abhat, 1983; Dincer and Rosen, 2002; Gil *et al.*, 2010; Villasmil *et al.*, 2019). However, it is found that many TES devices are separately installed (not built-in). Therefore, this paper will discuss the prospects of a combination of heat storage evaporator (HSE) and cold storage condenser (CSC) applied in ORC and its operation that HSE and CSC mean the TES and conventional main heat exchanger for power plant built in as one compact device (not separately). The strategy of hot and cold storage considering the charging and discharging time is described in this paper.

2 APPLIED HOT AND COLD STORAGE IN ORGANIC RANKINE CYCLE AND SIMPLE MATHEMATICAL MODEL

Intermittent cold and heat sources significantly influence the performance of ORC. It makes the operating condition of ORC fluctuate, which affects the way to expand its working fluid as an essential process to convert heat or volumetric into kinetic energy. For this reason, if a floating heat source is applied to power ORC, a regulation and storage system could be necessary to be installed to keep the process in its stable operating system. There are many possibilities of layouts implemented for a combination of ORC and TES that Kolasiński (2020) already discussed it. This paper will focus on the novelty of HSE and CSC integrated with ORC to collect the intermittent heat and cold energy. The scheme of this system is illustrated in Figure 1.

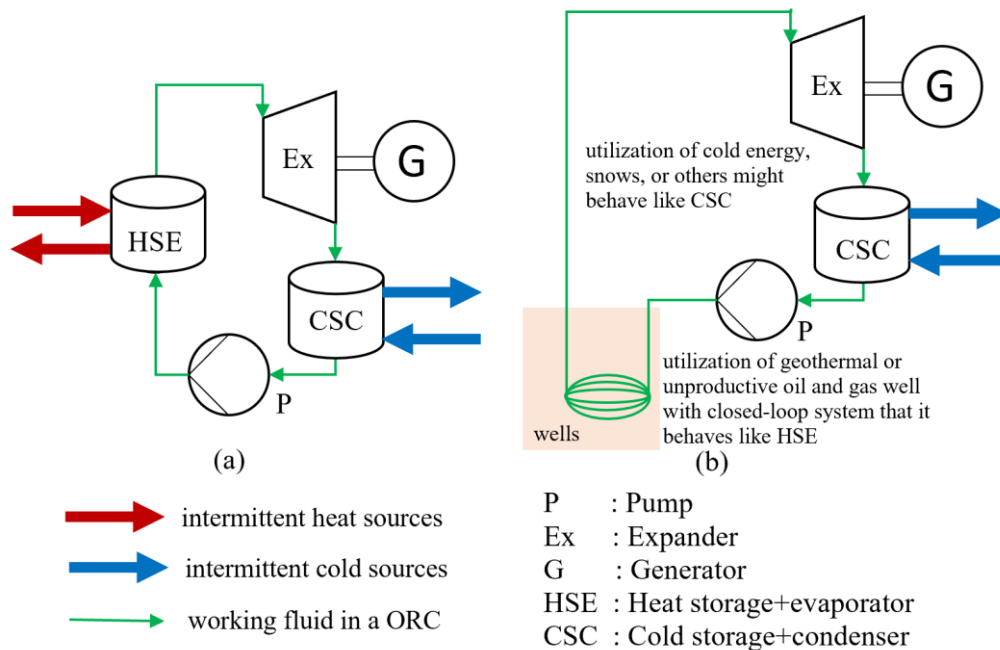

Figure 1: (a) An ORC system with integrated HSE and CSC, (b) an example system.

Figure 1(a) shows that the ORC system consists of heat transfer devices (an evaporator and a condenser) and pumping-expansion machines, however, in this configuration, HSE and CSC replace the main

classic heat exchangers (i.e., TES is developed not separately). The novelty of the presented system is that the application of HSE and CSC is promising because they could store the intermittent hot and cold in a certain period, reduce the area of installation and regulate the heat exchange ratio. In heat exchangers and TES, many considerations have to be taken into account, such as thermal capacity, heat transfer rate, heat losses, economical aspect, thermal properties (thermal conductivity, specific heat, etc.), insulations, storage period, charging and discharging times, safety, and efficiency (Dincer and Rosen, 2002; Sarbu and Sebarchievici, 2018). The easy and economically justified way to store thermal energy is using sensible heat material like water or rocks (Domański and Fellah, 1998; Hasnain, 1998). The possibility of using rocks to store thermal energy is already proved by the implementation of an underground storage system of geothermal heat (Givoni, 1977; Menéndez *et al.*, 2019). Therefore, this simple layout (Figure 1(b)) could be found in a closed-loop geothermal system, where a geothermal reservoir is the heat storage, and heat is exploited directly by a closed-loop system, so the medium to carry geothermal heat could be used continuously. This approach is a promising solution because this scenario tends to reduce water usage in power generation. The scheme of the closed-loop geothermal system has been investigated by Song *et al.* (2018) and Sun *et al.* (2018). As an alternative, abandoned or unproductive oil and gas wells also could be exploited and activated as heat sources or heat sinks for power plants where the well is assumed to be HSE or CSE and the intermittent heat sources. The intermittent heat sources are potentially collected from solar thermal or waste heat from industrial process/residential heating systems, and then they are injected into the reservoir. Taking advantage of abandoned or unproductive oil and gas wells is beneficial in the economical aspect, it reduces the investment cost of power generation plants as the infrastructure has been already established.

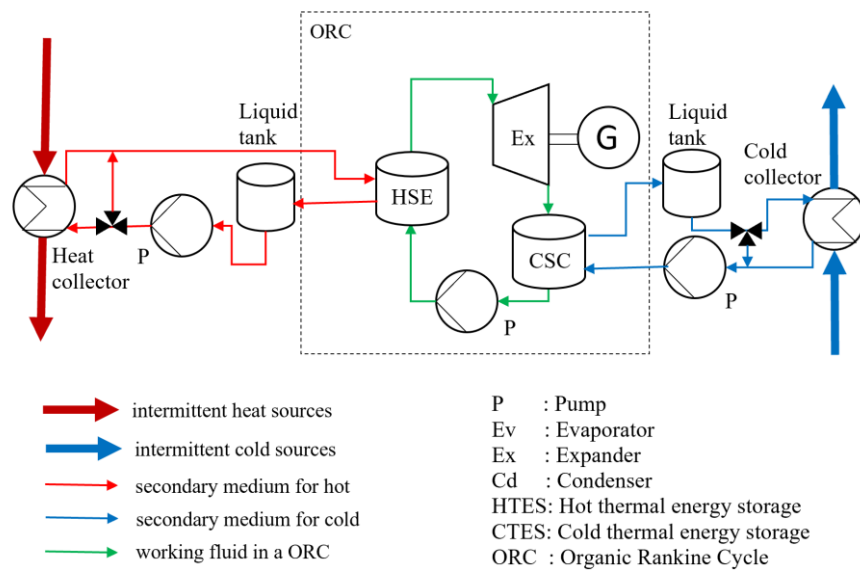

Figure 2: An alternative layout for a combination of ORC with HSE and CSC.

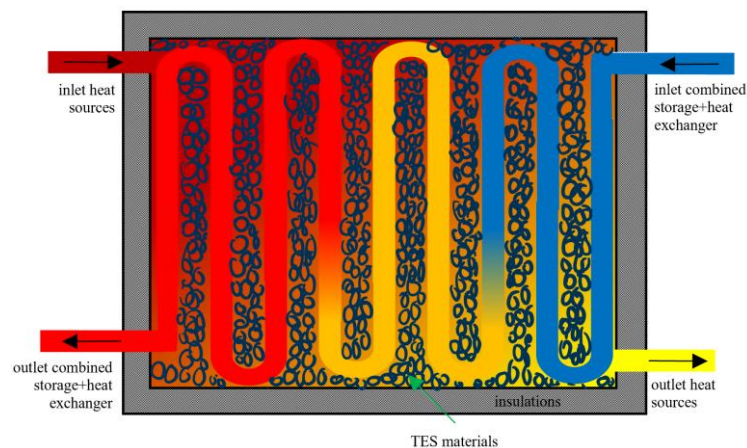

Figure 3: A simple HSE/CSC.

The other possible layout of the ORC system utilizing HSE and CSC is given in Figure 2. In this layout, the low-boiling organic working fluid and secondary working fluids lines are extended in the system if there is a severe issue where only limited space is available and technical issues like corrosive, and safety reasons are necessary to be considered. For this reason, the selection of secondary working fluids carrying the thermal energy in the second lines is mainly concerned with minimising the energy losses. Both hot and cold sides are able to utilize this scheme to absorb the intermittent thermal sources.

A simple mathematical model describes the conservation of mass and energy, referring to Equations (1) – (4). Since the HSE and CSC act as storage and primary heat exchangers, the flow rate in this study is described as volumetric flow where the discharge could be varied by opening the channel of the valve according to the needs. No leakage is assumed in the model.

$$\frac{dV}{dt} = \sum \dot{V}_{i/o} = \dot{V}_{in} - \dot{V}_{out} \quad (1)$$

$$\dot{V}_{in} = \dot{m}_{in} v_{in} \quad (2)$$

$$\dot{V}_{out} = \dot{m}_{out} v_{out} \quad (3)$$

$$m \frac{du}{dt} = \sum \dot{m}_{i/o} (h_{i/o} - u) + \sum \dot{Q} \quad (4)$$

The charging and discharging times and thermal energy storage efficiency are essential factors to design the storage system. Equations (5) – (11) describe these parameters,

$$\eta_{st} = \eta_{ch} \eta_{de} = \frac{Q_{st}}{\int \dot{Q}_{ch} dt} \frac{\int \dot{Q}_{de} dt}{Q_{st}} \quad (5)$$

$$\tau_{ch} = \frac{Q_{st}}{\dot{Q}_{ch}} \quad (6)$$

$$\tau_{de} = \frac{Q_{st}}{\dot{Q}_{de}} \quad (7)$$

$$Q_{st} = V_{st} \rho C_{st} \Delta T_{st \rightarrow sr} \quad (8)$$

$$V_{st} = h_{st} A_{st} \quad (9)$$

$$\dot{Q}_{ch} = \dot{m}_{ch,sw} (h_{in,ch} - h_{out,ch}) = \dot{m}_{ch,sw} c_{ch,sw} (\Delta T_{ch,sw}) \quad (10)$$

$$\dot{Q}_{de} = \dot{m}_{de,wf} (h_{in,de} - h_{out,de}) = \dot{m}_{de,wf} c_{de,wf} (\Delta T_{de,wf}) \quad (11)$$

A charging time is a time to store thermal into storage and a discharging time is a time to utilize the stored heat/cold.

In this study, the modelling of ORC is set at a temperature of HSE maximum at 423.15 K and CSC minimum at 290.15 K using R245fa (CAS no. 460-73-1). The thermal properties of R245fa are taken from CoolProp (Bell *et al.*, 2014), and calculations are computed using MATLAB. R245fa is chosen as an example in this discussion because it is often used in experimental investigations on ORCs and shows good performance and temperature range. The boiling temperature of R245fa at atmospheric pressure is 288.19 K, and a critical temperature is 427 K (Bell *et al.*, 2014). In this modelling, assuming the internal efficiency of the pump and the expander is 0.75 that the expansion and pump process is modelled using Equations (12) and (13). The model for the evaporator and condenser is seen in Equations (14) and (15), furthermore, the efficiency of the cycle can be calculated by Equation (16).

$$\dot{W}_{ex} = \dot{m}_{wf} (h_{in,ex} - h_{out,is,ex}) \eta_{is,ex} \quad (12)$$

$$\dot{W}_p = \dot{m}_{wf} (h_{out,is,p} - h_{in,p}) / \eta_{is,p} \quad (13)$$

$$\dot{Q}_{HSE} = \dot{m}_{wf} (h_{out,HSE} - h_{in,HSE}) \quad (14)$$

$$\dot{Q}_{CSC} = \dot{m}_{wf} (h_{in,CSC} - h_{out,CSC}) \quad (15)$$

$$\eta_{ORC} = \frac{\dot{W}_{ex} - \dot{W}_p}{\dot{Q}_{HSE}} \quad (16)$$

Where subscript of is describes the isentropic process. The simulation will be computed with two scenarios that firstly the temperature range is kept at the same value 120 °C and another scenario decreases the temperature range from 126 °C to 100 °C. The simulation steps of these strategies could be seen in Figure 4.

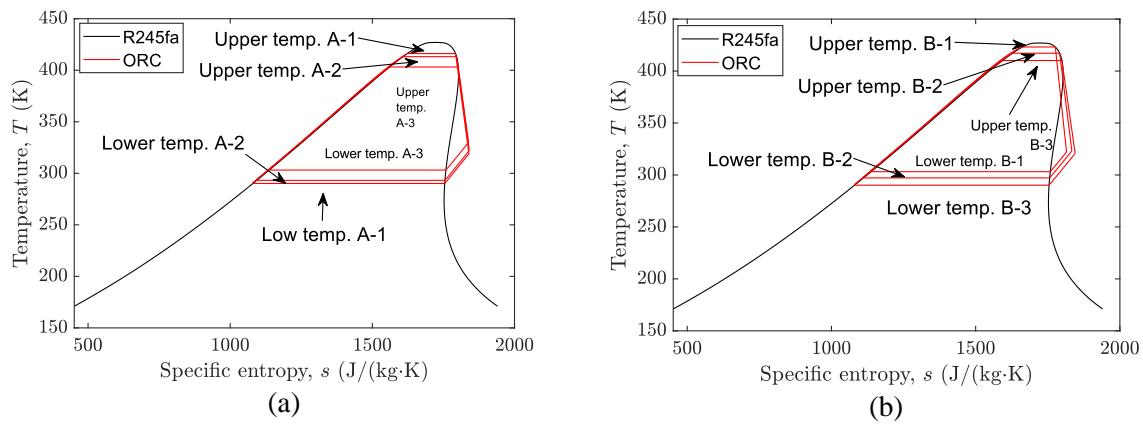

Figure 4: The simulation steps of the scenario for (a) decreasing the operating temperature range, and (b) keeping the operating temperature range.

3 FEATURES AND CHARACTERISTICS OF HOT STORAGE EVAPORATOR (HSE) AND COLD STORAGE CONDENSER (CSC)

The HSE and CSC are potentially interesting technologies that could be applied in modern ORCs. Many benefits could be taken from applying this technology, such as extending the operation time of the system, taking up much less space (i.e., space saving), a possibility to reduce instrumentation system, a possibility to simplify control system design, and compact. It seems that this combination indicates cost-saving over the separate machine of similar quality that perhaps at the beginning, this brand-new advanced combination might be quite expensive. However, as key design conditions of the HSE, CSC and ORC system, the charging and discharging times have to be taken into account in the system operation strategy. The simple way to understand charging and discharging times are illustrated in Figure 5.

The charging and discharging times are often found to be one of the key properties related to energy storage technology. Since the weather might significantly influence the intermittent heat sources. It is also related to water and air as common cooling sources which temperature could vary by 5 – 10 °C daily, or by 15 – 25 °C annum regarding the elevation of the place and the location (i.e., in the tropical or subtropical area). This condition is considered as interference which could lead to a decrease in the efficiency of the cycle. The features and characteristics of the TES are following the strategy of using it in the integrated system. Table 1 reports the possible scenarios and characteristics of the TES implemented in the ORC system.

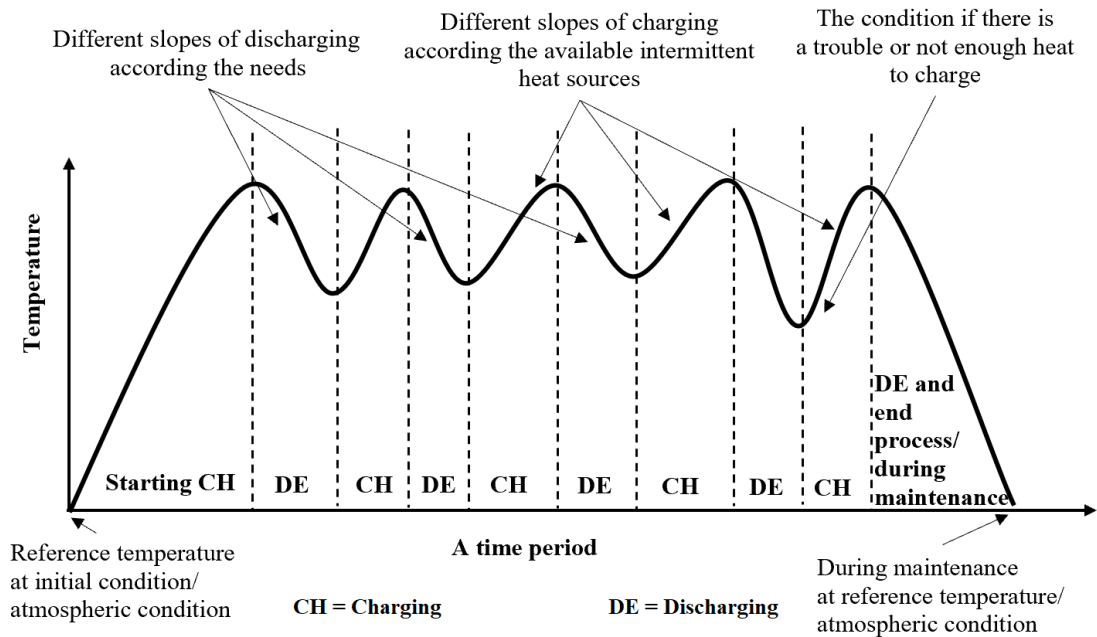

Figure 5: An illustration of the operating condition of charging and discharging in a basic thermal storage system.

Table 1: The potential operating conditions of ORC combined with HSE and CSC.

No	Cases	Operating principle and operating conditions
1		<p>The process starts operating at the same initial time. The “A” mark in the left figure indicates a range when the HSE and CSC are at the maximal operation. In a certain period, there are no more excess heat and cold storing to combined devices, therefore, the cycles consume the heat and cold from these storages (it also means that devices release the stored hot and cold energy) until reaches a certain point (see “B” mark in left figure). It seems that the performance of the power plant could decrease as the temperature range drops. It appears that from A to B, the condition follows $\tau_{de,HSE} = \tau_{de,CSC}$ when both devices start losing energy. The “C” mark in the left figure also follows this boundary. It might be a drawback because it is found that at a certain period there is a minimum performance of the cycle (refers to “B” range). In this case, the time of charging and discharging corresponds with the way to regulate the mass flow rate of the secondary lines, that the scheme of these secondary lines introduced in the ORC system is illustrated in Figure 2.</p>

Table 1 - continued: The potential operating conditions of ORC combined with HSE and CSC.

No	Cases	Operating principle and operating conditions
2		<p>The process starts operating at a different initial time. The “A” mark in the left figure indicates a range when the HSE and CSC are at the minimal and maximal operation, respectively. In a certain period, there is no more excess cold storing to CSC and there is heat excess that could be stored to HSE. Therefore, the cycles consume the cold from this storage (it also means that devices release the stored cold energy) and at the same time start storing the hot sources until reaches a certain point (see “B” mark in left figure). It appears that from A to B, the condition also follows $\tau_{ch,HSE} = \tau_{de,CSC}$ when both devices start losing and storing the energy. The “C” mark in the left figure also follows this boundary. It might be an advantage for the cycle because it is found that starting different initial operating times and $\tau_{ch,HSE} = \tau_{de,CSC}$ could keep the temperature range of the hot and cold sources at the same level. This case could be described as a cycle implemented in the subtropical area when absorbing and storing heat in summer and collecting cold sources in winter. It is important to note that keeping the temperature range such as $A=B=C$ in the left figure is a good approach for stable performance and sustainability of the cycle.</p>
3		<p>The third case is similar to the second one in that the storage starts with a different initial operating time. In this case, clipped conditions on the peak are introduced due to limited characteristics of the HSE and CSC, regulating the system, additional load (i.e., retrofit system). This case could be also described as a cycle implemented in the subtropical area when absorbing and storing heat in summer and collecting cold sources in winter. It is important to note that keeping the temperature range such as $A=B=C$ in the left figure is a good approach for stable performance and sustainability of the cycle.</p>

The calculation results are presented in Figure 6 based on the Equations (12) – (16) and the applied strategies in Figure 4. The increment steps of the calculation are set at 1 °C. Obtained results show that more stable efficiency is obtained by applying TES and keeping ORC operating temperature range. If the ORC operating condition is not kept at the same temperature range (indicated by $\tau_{de,HSE} = \tau_{de,CSC}$), the performance of the system might be worsening, and it introduces minimal efficiency what will significantly affect the electricity production. The application of TES might avoid this big difference in maximal and minimal efficiency, which could be caused by decreasing the ORC operating temperature range.

In this investigation, it was observed that the $\tau_{de,HSE}$ and $\tau_{de,CSC}$ have a significant influence on the design of HSE and CSC in the ORC due to system efficiency. Therefore, in this case, the model predictive control strategy and design of ORC concerning the stability of the dynamic system should be considered in further research.

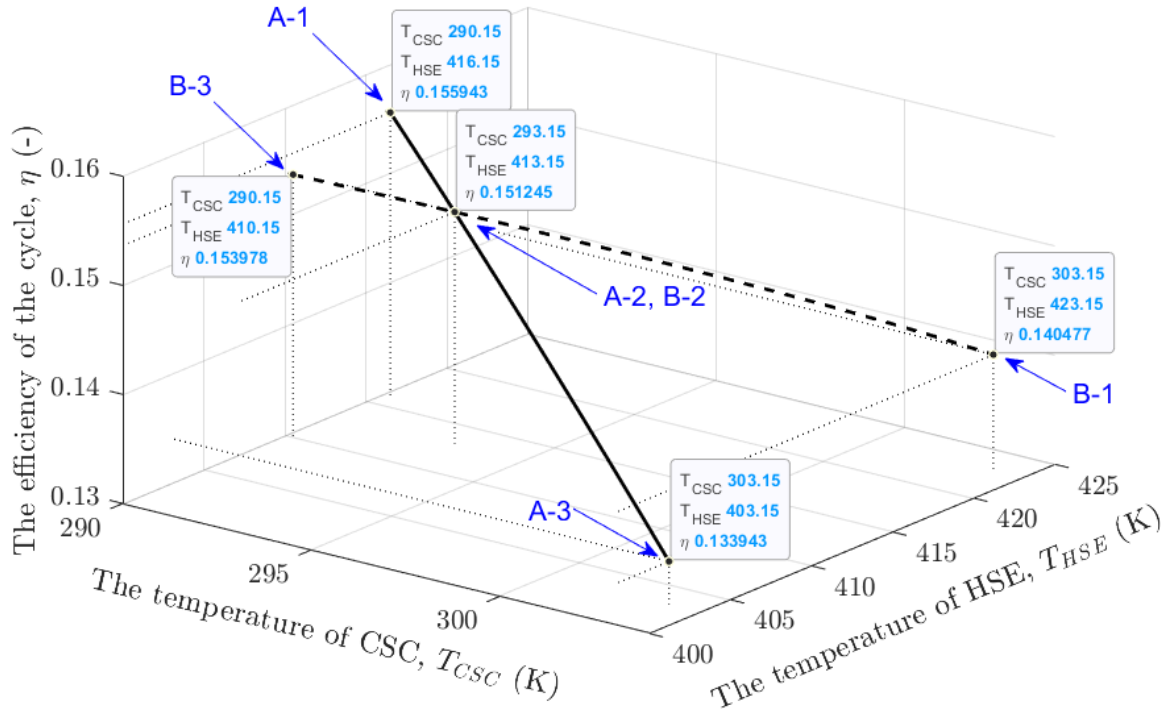

Figure 6: A comparison of the efficiency of the ORC with the same temperature range (a thick solid curve) and decreasing temperature range (a thick dash curve) where marks and parameters “A” and “B” refers to the steps in Figure 4.

4 CONCLUSIONS

This paper reports a literature review related to the novelty of the combination of TES and primary heat exchangers (an evaporator and a condenser) in ORC systems, so-called HSE and CSC. A mathematical model was discussed, paying attention to the critical aspect of HSE and SCS charging and discharging. The potential strategies of HSE and CSC application in ORC was introduced. The model shows that strategy aimed at keeping stability in the ORC system is essential concerning the charging and discharging times that are important to consider in the main design phase before HSE and CSC fabrication. This novelty could be implemented to utilize abandoned or unproductive oil and gas well for power generation, shallow underground or geothermal based on closed-loop ORC system combined with the solar thermal collector as the potential hot sources and snow or potential cold energy from liquefied natural gas (LNG) as cold sources. Also, it could be implemented to exploit waste heat from the residence heating system or industrial system and ocean thermal energy.

NOMENCLATURE

η	efficiency	(-)
τ	time	(s)
c	specific heat capacity	(J/(kg·K))
h	specific enthalpy	(J/kg)
m	mass	(kg)
\dot{m}	mass flow rate	(kg/s)

m	mass	(kg)
ρ	density	(kg/m ³)
Q	heat capacity	(J)
\dot{Q}	heat transfer rate	(W)
T	temperature	(K)
u	internal energy	(J)
V	volume	(m ³)
\dot{V}	volumetric flow rate	(m ³ /s)
v	specific volume	(m ³ /kg)

Subscript

ch	charging
CSC	cold storage+condenser
de	discharging
ex	expander
HSE	heat storage+evaporator
i/o	input/output
is	isentropic
p	pump
sr	surrounding
st	storing
sw	secondary working fluid
wf	working fluid

REFERENCES

- Abhat, A., 1983, Low temperature latent heat thermal energy storage: Heat storage materials, *Solar Energy*, 30, no 4, p. 313–332.
- Badr, O., O’Callaghan, P. W., Hussein, M., & Probert, S. D., 1984, Multi-vane expanders as prime movers for low-grade energy organic Rankine-cycle engines, *Applied Energy*, vol. 16, no 2, p.129-146.
- Bell, I. H., Wronski, J., Quoilin, S., & Lemort, V., 2014, Pure and Pseudo-pure Fluid Thermophysical Property Evaluation and the Open-Source Thermophysical Property Library CoolProp, *Industrial & Engineering Chemistry Research*, vol. 53, no. 6, p. 2498–2508.
- Chacartegui, R., Vigna, L., Becerra, J. A., & Verda, V., 2016, Analysis of two heat storage integrations for an Organic Rankine Cycle Parabolic trough solar power plant, *Energy Conversion and Management*, vol. 125, p. 353–367.
- Dincer, I., & Rosen, M., 2002, *Thermal energy storage: systems and applications*, John Wiley & Sons, West Sussex, p. 577.
- Domański, R., & Fellah, G., 1998, Thermoeconomic analysis of sensible heat, thermal energy storage systems, *Applied Thermal Engineering*, vol. 18, no. 8, p. 693–704.
- Dumont, O., Parthoens, A., Dickes, R., & Lemort, V., 2018, Experimental investigation and optimal performance assessment of four volumetric expanders (scroll, screw, piston and roots) tested in a small-scale organic Rankine cycle system, *Energy*, vol. 165, no. A, p. 1119–1127.
- Freeman, J., Guarracino, I., Kalogirou, S. A., & Markides, C. N., 2017, A small-scale solar organic Rankine cycle combined heat and power system with integrated thermal energy storage, *Applied Thermal Engineering*, vol. 127, p. 1543–1554.
- Gil, A., Medrano, M., Martorell, I., Lázaro, A., Dolado, P., Zalba, B., & Cabeza, L. F., 2010, State of the art on high temperature thermal energy storage for power generation. Part 1—Concepts, materials and modellization, *Renewable and Sustainable Energy Reviews*, vol. 14, no. 1, p. 31–55.
- Givoni, B., 1977, Underground longterm storage of solar energy—An overview, *Solar Energy*, vol. 19, no. 6, p. 617–623.

- Hasnain, S. M., 1998, Review on sustainable thermal energy storage technologies, Part I: heat storage materials and techniques, *Energy Conversion and Management*, vol. 39, no. 11, p. 1127–1138.
- Kolasiński, P., 2020, Experimental and modelling studies on the possible application of heat storage devices for powering the ORC (organic rankine cycle) systems, *Thermal Science and Engineering Progress*, vol. 19, p. 100586.
- Kolasiński, P., Błasiak, P., & Rak, J., 2016, Experimental and Numerical Analyses on the Rotary Vane Expander Operating Conditions in a Micro Organic Rankine Cycle System, *Energies*, vol. 9, no. 8, p. 606.
- Menéndez, J., Ordóñez, A., Álvarez, R., & Loredo, J., 2019, Energy from closed mines: Underground energy storage and geothermal applications, *Renewable and Sustainable Energy Reviews*, vol. 108, p. 498–512.
- Oró, E., de Gracia, A., Castell, A., Farid, M. M., & Cabeza, L. F., 2012, Review on phase change materials (PCMs) for cold thermal energy storage applications, *Applied Energy*, vol. 99, p. 513–533.
- Pantaleo, A. M., Fordham, J., Oyewunmi, O. A., De Palma, P., & Markides, C. N., 2018, Integrating cogeneration and intermittent waste-heat recovery in food processing: Microturbines vs. ORC systems in the coffee roasting industry, *Applied Energy*, vol. 225, p. 782–796.
- Pelay, U., Luo, L., Fan, Y., Stitou, D., & Rood, M., 2017, Thermal energy storage systems for concentrated solar power plants, *Renewable and Sustainable Energy Reviews*, vol. 79, p. 82–100.
- Sarbu, I., & Sebarchievici, C., 2018, A Comprehensive Review of Thermal Energy Storage, *Sustainability*, vol. 10, no. 1, p. 191.
- Smith, I. K., Stosic, N., & Kovacevic, A., 2014, Power recovery from low grade heat by means of screw expanders. Elsevier, Cambridge, p. 233.
- Song, X., Shi, Y., Li, G., Shen, Z., Hu, X., Lyu, Z., Zheng, R., & Wang, G., 2018, Numerical analysis of the heat production performance of a closed loop geothermal system, *Renewable Energy*, vol. 120, p. 365–378.
- Sun, F., Yao, Y., Li, G., & Li, X., 2018, Geothermal energy development by circulating CO₂ in a U-shaped closed loop geothermal system, *Energy Conversion and Management*, vol. 174, p. 971–982.
- Villasmil, W., Fischer, L. J., & Worlitschek, J., 2019, A review and evaluation of thermal insulation materials and methods for thermal energy storage systems, *Renewable and Sustainable Energy Reviews*, vol. 103, p. 71–84.
- Wang, Z., Lin, B., & Zhu, Y., 2015, Modeling and measurement study on an intermittent heating system of a residence in Cambridgeshire, *Building and Environment*, vol. 92, p. 380–386.
- Zalba, B., Marín, J. M., Cabeza, L. F., & Mehling, H., 2003, Review on thermal energy storage with phase change: materials, heat transfer analysis and applications. *Applied Thermal Engineering*, 23(3), 251–283.