

Architecture

Building History,  
Building  
Archaeology and  
Heritage  
Conservation

Tobias Busen, Miriam Knechtel, Clemens  
Knobling, Elke Nagel, Manfred Schuller,  
Birte Todt

# Measured Building Survey

# Measured Building Survey

Tobias Busen, Miriam Knechtel, Clemens Knobling,  
Elke Nagel, Manfred Schuller, Birte Todt

The German National Library has registered this publication in the German National Bibliography. Detailed bibliographic data are available on the Internet at <https://portal.dnb.de>.

## Imprint

### 1. Edition

Copyright © 2022 TUM.University Press

Copyright © 2022 Tobias Busen, Miriam Knechtel, Clemens Knobling,

Elke Nagel, Manfred Schuller, Birte Todt

All rights reserved

Translation: Christian W. Hess

Layout design and typesetting: Jörg Denkinger, German Archaeological Institute (DAI) Berlin

Cover design: Designbüro Josef Grillmeier Munich

Cover illustration: Fernando Alda

Translated and revised edition of the textbook with the original title “Bauaufnahme”, which was published by the Technical University of Munich in 2017

TUM.University Press

Technical University of Munich

Arcisstrasse 21

80333 Munich

Germany

DOI: 10.14459/2021md1636474

ISBN printed edition: 978-3-95884-038-6

[www.tum.de](http://www.tum.de)

The English edition was realized within the framework of the “Zero Hour” project of the Archaeological Heritage Network (ArcHerNet). It was made possible by the kind support of the German Archaeological Institute (DAI) and the Federal Foreign Office.



# Contents

<b>Forward</b>	5
<b>A. Fundamentals</b>	7
1. History of Measured Building Surveys	
2. What is measured and how?	
3. Applications and Economy	
<b>B. Manual Measurement and Recording</b>	19
1. Independent Systems of Measurement	
2. Establishing the Measurement Grid	
3. Calibration and Transfer of the Measurement Grid	
4. Measurement and Drawing	
5. Details	
<b>C. Optical and Visual Aids</b>	35
1. Optical Level	
2. Laser	
3. Theodolite	
<b>D. Electronic Building Surveys</b>	41
1. Properties	
2. Tachymeter/Total Station	
3. 3D-Scans	
<b>Examples from the Activities of the Department</b>	52
<b>E. Photogrammetry</b>	71
1. Definition and Terminology	
2. Correcting for Distortion	
3. Further Methods	
<b>F. Planning a Comprehensive Building Survey</b>	79
1. Project Organization	
2. Feature Analysis and Feature Catalog	
3. Room Data Sheets	
4. Mapping and Construction Phase Plans	
5. Methods of Dating	
<b>G. Appendix</b>	97
1. Presentation	
2. Glossary	
3. List of Illustrations	
4. Bibliography	

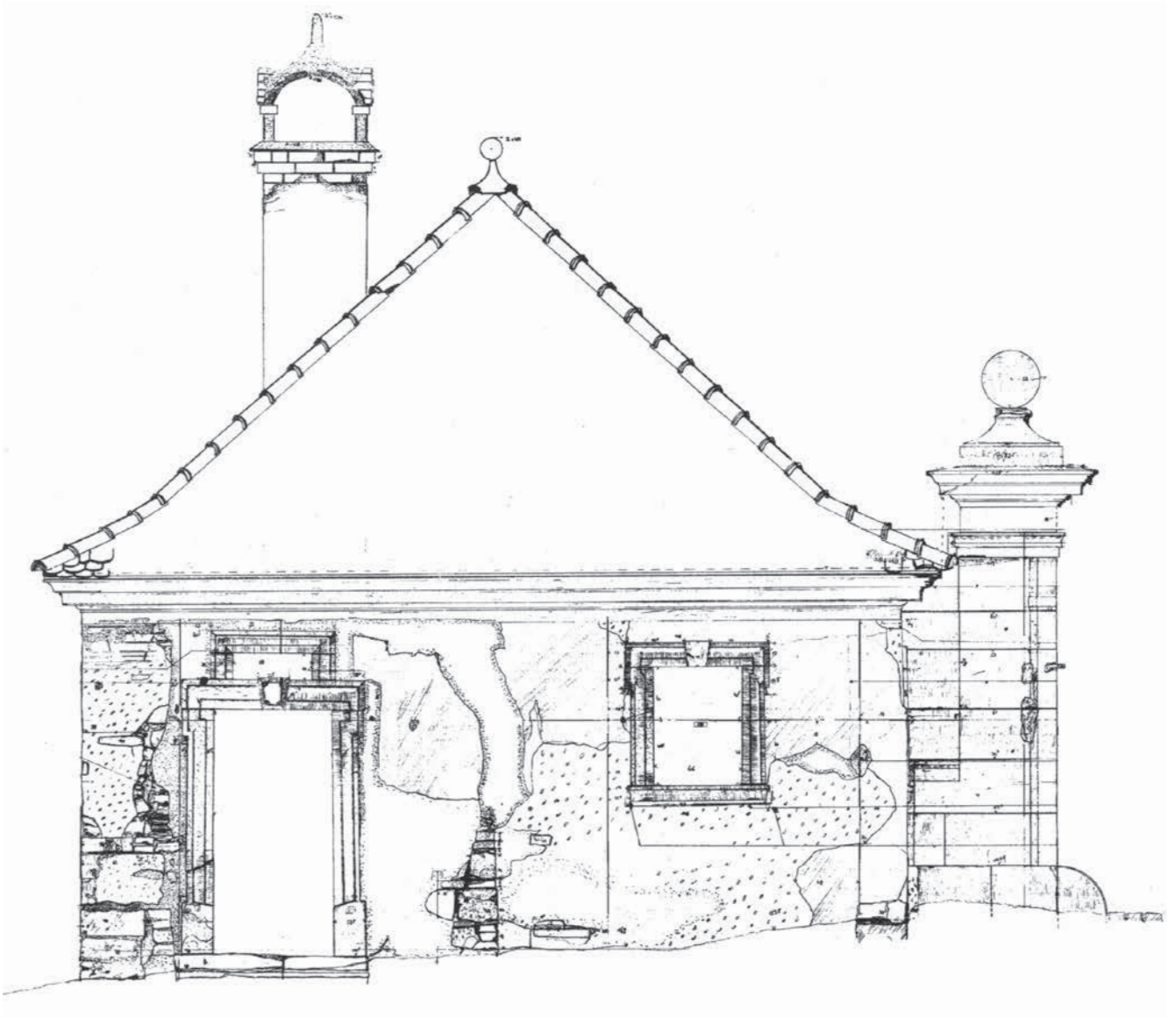

*Gatehouse in Oberschwappach, west view, manual drawing.*

## Forward

The term measured building survey is self-explanatory: An existing building is precisely measured and recorded. Just as a complete design for a building which is to be newly constructed depicts it in its entirety, including its layout, sections, views, and details, a building recording documents an existing building in the same way and in the same architectural language. The building, building complex, or ruins, regardless from which time period, are recorded together with all of their details of construction and form, deviations in angles, deformations which may have occurred over time, damages, alterations, and renovations. The process can pursue two main goals. The first is scientific: The recorded measurements provide the most important basis for the study of a building's history, with the aim of clarifying and explaining its age, original appearance, changes, functions, and peculiarities of construction. The second goal is to provide a basis for further construction work on a historic building: as a rule, planning documents for older buildings are either unavailable or are wholly inadequate. Even when they are available, they only poorly reflect the condition of the building as it developed over time, and which has often been radically changed. The search for planning documents for simple buildings such as farm- or townhouses or for medieval or even older buildings will often be fruitless. How, then, can plans be made when alterations, additions, or renovations are called for? Building measurement and recording provides the essential documentation required for any further steps. This documentation allows us to recognize the strengths and weaknesses of the

construction, damages, and the complex layout of rooms. It also allows us to distinguish between important and less important areas. Only in this way can new plans be made which can prevent irreversible changes in important areas, which take the basic construction into account, and which allow for an exact calculation of costs.

A measured survey is a task for an architect. Every architect should be able to document simpler buildings according to the prescribed requirements, and should be able to understand and incorporate measures undertaken by the specialists responsible. Conversely, these specialists are architects who have been additionally trained as architectural historians. Insights into the field of building survey are provided by BA-programs in Architecture, while more in-depth training, up to and including a specialization as architectural historian, are provided by the MA-programs of various technical universities. Through the revolution in new technologies for survey equipment and the development of electronically guided planning, a development which was unforeseeable only a few years ago, the number of possible applications of building surveys has greatly increased, while the demands required by this sort of work have in some respects changed. The basic principles, however, have remained the same. It still holds that the best building surveys are conducted directly on site, regardless of whether they are made traditionally by hand or revised according to the most modern methods of scanning.

*Manfred Schuller*



# Fundamentals

---

## 1. History of Measured Building Surveys

Since the time when architects first began to plan, they have also measured. The first known representative of the profession, the Egyptian Imhotep from the time of the Old Kingdom (ca. 2700 BC), already had to accurately measure the construction sites of the pyramids before he could begin with the planning itself. Classical building surveys are concerned with the documentation of pre-existing buildings by means of precisely measured plan drawings. The task of incorporating pre-existing architecture into the creation and revision of plans is a natural consequence of building: architects have thus always been familiar with the challenges involved. What the recording of building surveys may have looked like in the ancient world and in the Middle Ages is unknown, since no such recording has been preserved. We are on more certain ground when we reach the time of about 1500 AD, during the Renaissance, when large numbers of architects studied the buildings and ruins of antiquity and preserved them through their recordings. These served as the basis for the development of their own architectural language. Survey records are still preserved from the best of the architects of this revolutionary period, including Bramante, Raffaello, and Palladio, to name only a few. This time period witnessed the development of a new method of depiction, the orthogonal projection of layout, aspect, and profile, which still remains common to every plan and building record today. Developments in the quality of paper and its general availability helped to further these trends as well. Drawings were usually made with a silverpoint stylus which allowed for precise lines, comparable to those of a modern pencil. The combination of silverpoint and paper led to an exceptional suitability of these drawings for long-term storage, thanks to which many are still preserved today. The recorded measurements were noted in the

survey records. Although often schematic, these were drawn at an exact scale. Many of the drawings were most likely created at the site of the ruins or monuments themselves. Since the architects were especially interested in the former appearance of the buildings, they often added their own interpretations of the original structure to the depiction of the preserved remains, which could lead to scientifically inaccurate reconstructions. Buildings could also be recorded on a much larger scale, for example during the measured survey of entire cities. Precise recordings formed the essential basis of epoch-making works such as the bird's-eye view of Venice by de Barbari around 1500 and the models of Bavarian residences by the master turner Jakob Sandtner in the 1570s. The most advanced devices of the time were employed for these extremely challenging tasks, including devices for measuring angles, predecessors of the theodolite.

Already in the 17th century, building surveys were used for mapping and assessing damages. A famous and particularly elaborate example is the recording of the Church of Saint Peter in Rome (Carlo Fontana: *Il tempio Vaticano e sua origine*, Rome 1694). Towards the end of the 17th century, measured surveys also began to play a role in purely scientific research. In 1682, Antoine Desgodetz, under commission by the Parisian Académie Royale d'Architecture, produced excellent survey records for the most important buildings in Rome, published in his *Édifices antiques de Rome. Mesurés très exactement*. The four-year Rome stipend for the best young architects in France, the Grand Prix de Rome, subsequently gave steady impulse to new studies on ancient buildings, resulting in grand survey records and reconstructions. Many of these architectural historians would go on to become some of the best architects of their age. From the middle of the 18th century onward, there



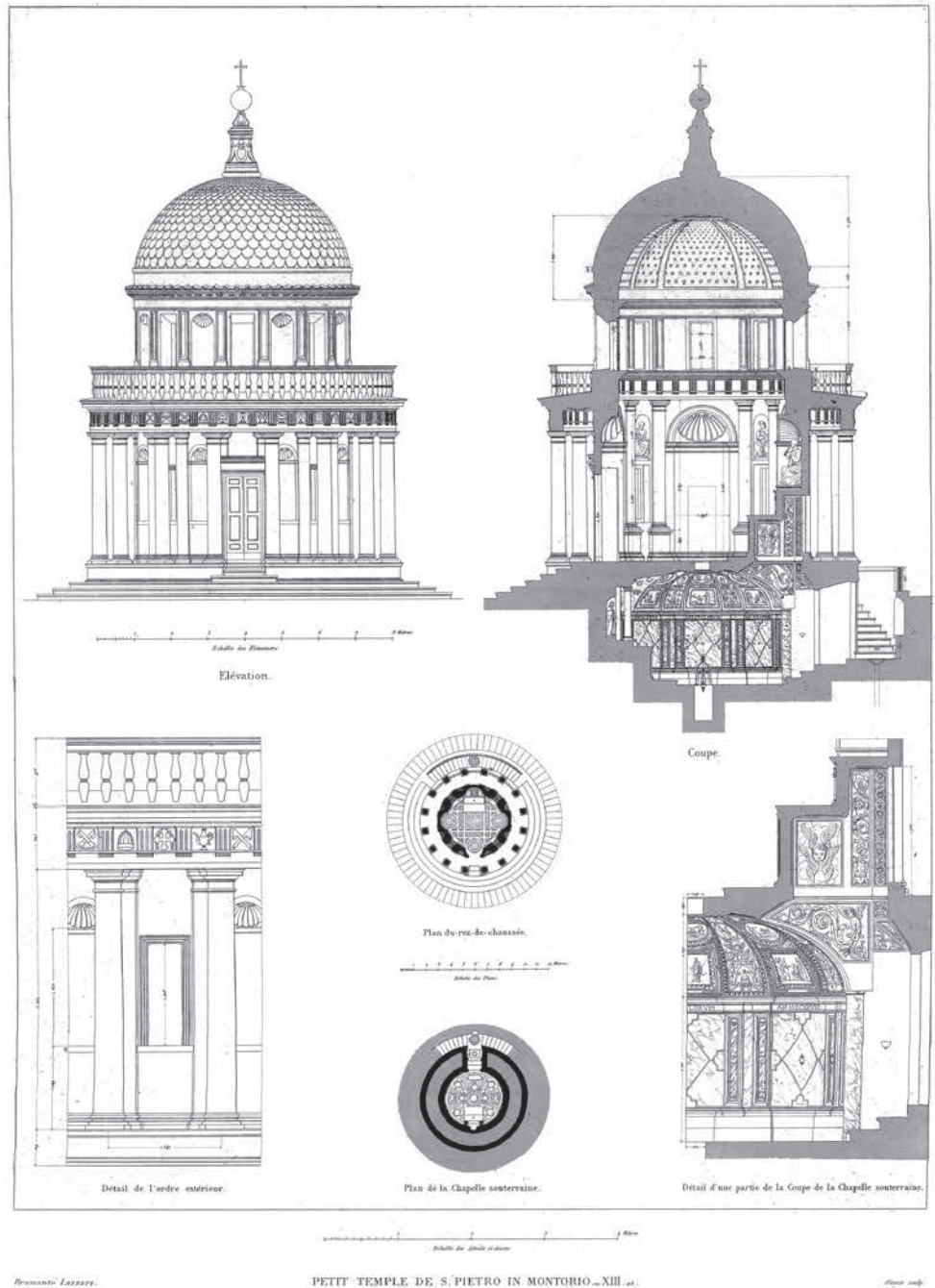

The Tempietto of Bramante in San Pietro in Montorio, Building Recording from P. Letarouilly, *Édifices de Rome moderne*, Paris 1840.

also developed an interest in the architecture of Southern Italy and Greece. The works of English architects in particular set the trend for the sciences. James Stuart and Nicholas Revett were commissioned by the English Society of Dilettanti, founded in 1732, to travel to Athens, which was at the time still under Ottoman rule. There, they completed their epoch-making work *The Antiquities of Athens*, published in 1762. The great Egyptian Expedition under

Napoleon, more scientific than military in character, brought the predecessors of today's architectural historians into regions previously unknown and produced ample results. The resulting *Description de l'Égypte*, which began to appear in 1809, contained not only depictions of Egyptian antiquity still important today, but also of medieval and Islamic buildings recorded in remarkably good detail. Measured building surveys proved indis-

pensible to the budding link between scientific and practical concerns for the preservation of monuments. Leo von Klenze, for example, originally from Munich, thus had the ancient monuments of Athens documented, protected, and maintained in the 1830s. But it was not only the ancient world which played such a prominent role in the 19th century. Another example, Paul Letarouilly's *Édifices de Rome moderne*, published between 1849 and 1866, represented an incredible achievement in the recording of post-medieval buildings. Letarouilly's precision in measurements and detailed observations still serve as an indispensable basis for many architectural historians. The great monuments of his own country, in France, particularly the medieval cathedrals, monastery churches, and palaces, had become so dilapidated since the upheavals of the revolution that they were in urgent need of restoration in order to save the older structures. Eugène-Emmanuel Viollet-le-Duc and his school managed to provide exemplary preliminary research into the buildings which needed to be restored. The resulting recordings of the buildings were sometimes accurate to the individual stones. These recordings provided a basis for determining the measures necessary for restoration block by block: this methodical approach is even today not a universal standard. Through the documentation of so many buildings, significant knowledge of medieval construction techniques could be accumulated. In its descriptions and images, Viollet-le-Duc's *Dictionnaire raisonné de architecture du XI au XVIe siècle*, published from 1854–1868, continues to provide outstanding insights into medieval constructions from their foundations to their cladding even today. Germany also saw its medieval monuments brought back from oblivion. Already at an early time, from 1799 to 1803, Friedrich Gilly and Friedrich Frick published a splendid monograph on the reconstructed Gothic state of the Marienburg in Prussia, based on an exact measured survey. Highly precise planning documents and detailed analyses of buildings were also required by the "Domvollendungen" which

had come into fashion in this period, the completion of great, medieval churches from Florence to Prague which had so far remained unfinished. The most famous example is the Cathedral of Cologne. First studies looked into the medieval torso and the points of connection which still awaited further additions. The results of these studies were then reconciled with the medieval plans, which in the meantime had been retrieved. The approach was methodologically flawless, as the medieval sections, which would be sacrificed for the Neo-Gothic expansion, were drawn and documented using some of the earliest photography. The measured survey even recorded the giant wooden crane on the torso of the southern tower, a first-rate technological monument.

We can also point to similar developments in other European countries. After a long controversy on the care and preservation of monuments, influenced by the writings of John Ruskin, Venice restored the medieval facades of San Marco and the Doge's Palace. Annibale Forcellini's restorations of the Doge's Palace from 1873 to 1887 still serve as models of measures taken for the care of important building monuments today. In preparation for his work, Forcellini had precise building records be drawn, which included soundings of the foundations, all sorts of damages, technical details such as anchor plates, truss connections, etc. These records form the basis for his detailed plan of the measures to be taken, which document stone by stone the necessary replacements, new anchor systems optimized according to a modern understanding of statics, various cuts in the stone, etc. The activities of a group of architects from German-speaking countries moved in an entirely different direction. Around 1900, in Austria, Switzerland, and Germany, they compiled a collection of survey documents for typical farmsteads. Though the resulting records, which document the layout, different views, sections, and details such as windows, doors, and ovens, vary in quality, they also for the first time drew attention not to distinguished monuments, but to simpler buildings. It was thus recognized that the effects of the

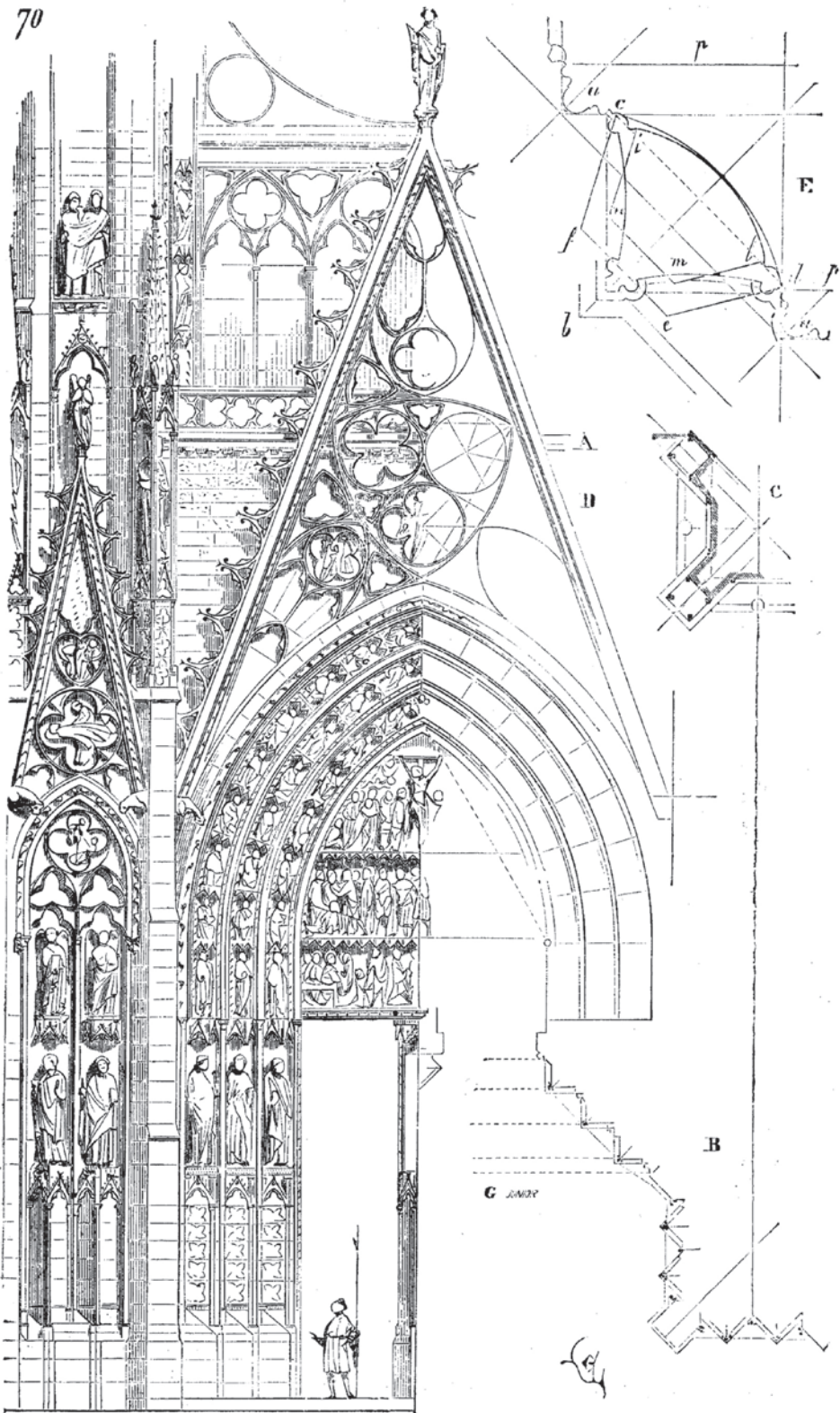

Main portal of the Cathedral of Rouen, Viollet-le-Duc 1854–68.

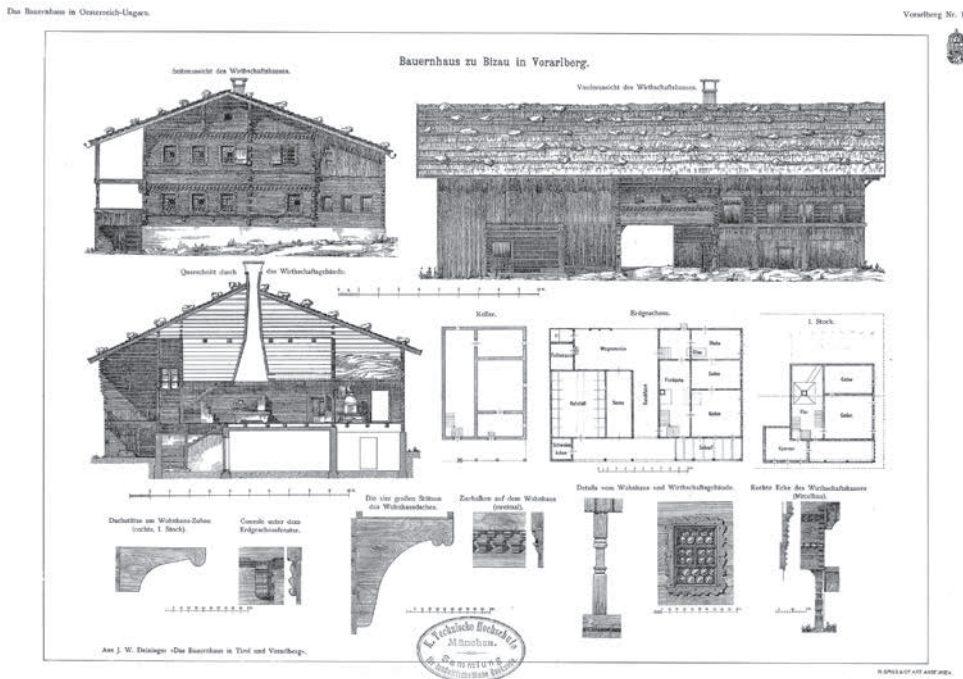

*Drawn documentation for a farm house in Bizau/ Vorarlberg, 1906.*

Industrial Revolution had endangered the continued existence of this building type, which had defined the land throughout the centuries. It was at least possible to preserve them for posterity through drawings and brief descriptions.

Studies were also devoted to the town houses of medieval cities throughout Europe. In turn, archaeological research was expanded well beyond the limits of the Mediterranean to include Egypt, Babylon, and even Central and South America. Through this research, scientific methods of the measured survey came to be highly developed, including the strict separation of findings from amendments or reconstruction. Together with the training of architects based on historical forms of architecture, these diverse tasks led to the integration of measured survey into the academic education of architects from the outset.

Over many decades of the 20th century, the methods of measured survey which had been developed and its prerequisite instruments remained stable. Beginning in 1980, Gert Th. Mader from the Bavarian State Office for Monument Protection, who for many years also served as honorary professor and teacher at the Technical University of Munich, further developed the measured building survey for the

purpose of preserving historic landmarks, based on methods of research which had been applied to ancient monuments. The deformation-true measured survey, which faithfully and accurately recorded all deformations of a historic building, became an internationally recognized standard for the preparation of conservation measures. Exact planning documents which recorded all deformations, visible damages, constructions, and historical construction phases in greatest detail allow for a reliable work plan. This in turn helps to prevent unnecessary changes and allows for a reliable estimate of costs.

The scientific study of historic buildings, from Ancient Egyptian ruins to Greek temples, Gothic cathedrals, Baroque castles, and classicizing museum structures, from medieval farmhouses to mills of the 19th century, is today essentially based on measured building surveys, conducted by trained architectural historians. Now as ever, measured survey is thus still taught in the remaining departments for architectural history at today's universities, even as the revolution in technology and drawing applications at the turn of the millennium has made a re-orientation of the programs necessary. This new orientation will also be addressed in the following chapters.



*Drawing board on tripod for the direct and clean transfer of measurements of a historic building onto a drawing.*

## 2. What is measured and how?

### What and why?

Every type of building of every age can be precisely measured with the methods of a measured survey, taking the relevant deformations into account, and can be depicted in plan drawings (layout, views, and profiles).

As already described in the forward to this volume, when preparing restorations or modifications to a historic building, plans are often either unavailable or have been made obsolete through various alterations and deformations of the original plans.

A measured building survey true to any deformations also serves as an exact record of the present condition of a historic building.

This record includes all important findings on the history of the building as well as short explanatory comments, which may take the form of a plan indicating the age of the individual parts of a building based on the evaluation of all primary and secondary sources.

The drawings thus depict the current condition of the building as well as any deformations, damages, or alterations.

### “Measured Recording” vs. “Deformation-True Measured Survey”

For a quick record (for example with a measuring stick, distometer, etc.), the spatial dimensions (including length and width, height, as applicable) are roughly measured so that the size of the space can be depicted as a floor plan or the vertical scale depicted in a section view with minimal outlay. Since this quick recording is made under the presumption that the surfaces which delimit the space (walls, ceilings, floors) are simply linear, without changes in the thickness of the walls or variation in the height of the ceilings, and joined at right angles, information on the actual spatial geometry and defining characteristics of the property are missing.

In contrast, a measured survey true to any existing deformations (“deformation-true”) is based on an independent measuring grid which allows for the ge-

ometrically correct depiction of spatial structures, including the thickness of all walls, the height of the ceilings, and any changes in their course. Exact measurements as well as precision and faithful attention to detail in the drawing allow for a large amount of information to be provided in a small space, while still remaining legible.

### Parameters for a Measured Building Survey

The measurement grid mentioned above can consist of either a string grid, traditionally used for manual survey measurement, a laser plane, or marked reference points. The last two are needed for a tachymetric survey. The grid should place all spatial measures into relationship with one another both horizontally and vertically, that is, it should include all spaces which need to be measured and should also show any connections of internal and external spaces as well as of any floors, as needed. Measurement grids which are physically present, such as string lines or laser planes, also additionally require that they be located on a horizontal or vertical level, which also serves as the horizon of measurement (► Chap. B, D).

The properties to be measured are as a rule quite different from one another. Different tasks will arise based on the nature of the property, which can range from large buildings such as cathedrals to the smallest farmhouse. Based on the size, complexity, accessibility, and expenditure of materials and time, a suitable method of survey must be decided separately for each property. The determination of the method or combination of methods also depends on the goals of the building survey. The creation of modern plans, renovation, or construction on the building usually requires CAD-drawings, while some areas of research on architectural history may benefit from manual drawings. In addition to classical measured surveys carried out manually with hand drawings or tachymetric surveys supported by CAD,

various combinations of both methods are also possible. Tachymetrically measured points, for example, can thus serve as the basic framework for manual drawings. It is also possible to supplement CAD-drawings with manually recorded details, such as information on window profiles. Depending on the property, it might also be expedient to record the survey with a manual survey supported with CAD-drawing on site. These methods and their possible combinations will be presented as the subject of individual sections and chapters below, which will also demonstrate their application on the basis of particular projects described as examples.

#### Representation and Scale

The survey record always depicts the condition of the property at the time of the survey. Damages and defects are drawn as such and are not corrected to reflect a hypothetically original state. All observations and findings made on site (such as features indicative of dating) are also entered into the original drawings. Findings can be indicated in the form of short textual comments and/or through cross hatching or annotated symbols.

Reconstruction plans of the original or intermediate states can, however, be developed based on the measured survey and should be specially indicated as such. Plans of building phases which indicate the time of construction of the building or its parts can also be created on the basis of the survey records.

The deciding factor for the creation of the layout or the amount of information pro-

vided is the scale of the drawing, which itself depends on the type of property and the goals of the building survey.

As a rule, the drawing should contain all data relevant to the architectural history of the building, for example material or the treatment of surfaces, but also all findings relevant to the analysis of the property, such as indicators of dating and evidence of alterations.

If a smaller scale (1:50–1:200) is chosen due to the size of the property, detailed drawings in a larger scale should suffice for critical areas in order to provide clarification, or in some cases to support the analysis of the structure. In contrast, properties which regularly exhibit a large number of diagnostic finds throughout should be drawn accordingly at a larger scale (1:20/25–1:1). The precision of measurements should correlate to the precision of the drawing. Depending on the scale, it can be acceptable that the measurements taken are then rounded either up or down, within a certain degree of tolerance (► Chap. G.1).

In addition to the drawings, the survey record can also include written descriptions of the building, an evaluation of findings, scientific dating (C14 or dendrochronology), and room data sheets or photographic documentation. Their contents can either supplement or define the findings more precisely. Through photographs, room data sheets or photographic documentation can contribute to the overall image, character, and configuration of the rooms (► Chap. F).



*“Unterer Ymgramhof”  
in Mazon, located above  
Neumarkt in South Tyrol  
(photographed from the  
southwest).*

### Short Presentation of the Project “Unterer Ymgramhof”

This guide to measured building surveys is based on the project “Unterer Ymgramhof”, conducted by the Chair of Building History, Building Archaeology and Conservation. This residence, located in South Tyrol, was the subject of an exemplary, deformation-true measured building survey conducted in 2011/12 by means of various methods of measurement and drawing in order to compare the methods, compare their strengths and weaknesses, and evaluate the results. The large, three-story, free-standing residence includes a high ground floor consisting of two large, vaulted rooms and annexes as well as two residential floors arranged around a central corridor, flanked by two rooms on each side. A particular method of measurement was individually chosen to create the floor plan of each floor as well as for the sections.

The vaulted ground floor and the third story were both measured using tachymetric measuring (using a Leica TS02 or Leica Builder) and drawn with the aid of a computer. The second story, which was particularly rich in detail, was recorded by the traditional method of a string grid and manual drawing. For the measure-

ment grid, a system was created consisting of three main axes, supplemented by a secondary system of string lines which closely followed the course of the walls. While the vertical section was created entirely by hand with the help of a string grid, plumb lines, and laser level, the vertical sections were recorded tachymetrically and in CAD. The CAD-drawings were subsequently revised and where necessary supplemented by information from manual sketches, particularly for details such as window frames, door jambs, etc. Both the manual drawings of the ground floor of the second story and the longitudinal section was scanned and redrawn in CAD in order to establish a complete digital set of plans for the property. The views were derived from photographs corrected for distortion from photographic mosaics. A plan of the construction phases was developed and reconstruction drawings were completed on the basis of the planning material, the analysis of the finds, and dendrochronological dating. The chapters on manual survey recording (► Chap. B), tachymetric recording (► Chap. D) and photographic perspective control (► Chap. E) each present and explain in detail one step of the completed project.





*Longitudinal section of the "Unterer Yngrahamhof". The vaulted rooms of the ground floor and the hall in the middle of the house of the second and third floors are clearly visible.*

### 3. Applications and Economy

As mentioned above, there are two basic reasons for measuring and documenting buildings: either to gain scientific knowledge or to create a basis for planning when working with the (historic) structure of a building.

The scientific discipline of studying buildings draws its essential use from the analysis of existing structures. With the help of precise documentation, conclusions can be drawn and evidence provided regarding their technical and architectural state. The building recording serves on the one hand as a source for collecting insights into this state, on the other hand as a basis for creating scientific plans for presenting these findings. Plans for reconstruction or plans which indicate the age of particular parts of the structure provide a good example. For scientific purposes, the building recording needs to conform to the highest degree of accuracy required. In many cases, the method of choice will be manual measurement, since this requires intensive observation and also provides the greatest number of possibilities for individual representation. When the recording is meant to serve as the basis for planning further work, economic aspects should also be considered. It is often the case that no useful documentation is available for historic buildings, though these are an absolute prerequisite for extensive construction work. Conventional recording (done by an

architect) is usually insufficient for these purposes, as deformations and damages need to be precisely documented.

Without this detailed knowledge of the property in question, architects, structural engineers, and other specialists involved in planning are unable to deal with individual problems from the outset or to take them into account in their proposed solutions. The negative consequences during planning and construction work would mean a loss of time and resources. Once the building has been measured and recorded, including any deformations on the site, the architectural historian can directly assist in the planning of any measures to be taken.

In addition, building measurement and recording serves as an essential basis for the identification of areas as historical monuments, which can be clearly distinguished from areas of a building site not relevant to preserving the monument. The larger the building and better its condition and location, the greater will be the financial value of any insights gained through the recording. In planning work on historical areas, the building recording also contributes to determining basic tasks which need to be carried out. For this reason, the responsible monument authority will often commission a building survey during the planning phase of work to be carried out on more delicate areas of monuments.



*Minimally invasive mount of an independent string measurement grid in the corner of a room.*

# Manual Measurement and Recording

## 1. Independent Systems of Measurement

The foundation of every building recording that accurately records any deformations is an independent system of measurement which consists of horizontal and vertical measuring planes according to a defined coordinate system.

“Independent” means that measurement and recording will never use the building itself as a reference point, but will instead derive measurements from the system used. This is the only way to ensure that the spatial setting will be recorded correctly.

The height and position of the measurement planes is determined at the beginning of every recording, based on the property to be measured (► Chap. B.2.1). These planes will be marked by string stretched throughout the room or by laser-beams. The position of every point is determined by two coordinates (► Chap. B.4). For examples of completed plans of manual measurements see pp. 52 ff.

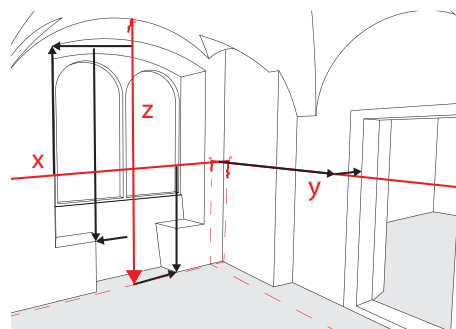
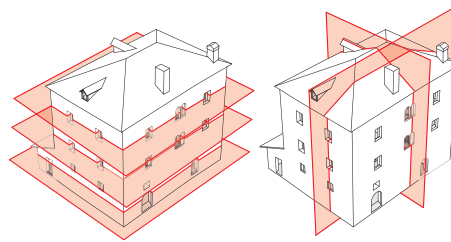

### Material

#### For each Team:

- project folder
- masking tape, removable tape
- (steel) ruler, tee-square
- screws, (steel) nails of various sizes
- pins, tacks, hammer, pliers
- mason's twine (not packing string! the line should not be elastic!)
- measuring tape (at least 10m length), folding rule (3 m)
- plumb line (for wallpaper)
- mason's level
- cutter, screw clamps
- wire rods for soundings
- optional: curve template, paint markers, wax crayons, small saw, chisel, scalpel, brooms or brushes, contour gauge, caliper gauge

#### For each Person:

- drawing paper (acid- and wood-free, minimum weight 150g/m<sup>2</sup>) or non-warping film
- sketch paper, writing pad
- drawing board, possibly with tripod
- mechanical pencils + lead refills of varying hardness (6H to 2H, definitely not softer)
- eraser pencil, eraser
- sharpener
- drawing compasses
- set squares (45° + 30/60°)
- triangle
- folding rule (2 m, white, wooden, with oiled hinges)
- drawing broom
- head lamp

## 2. Establishing the Measurement Grid

Establish the measurement grid carefully, in order to avoid any inaccuracies and errors from the beginning!

### 2.1 Floor plan

#### 2.1.1 Determining and Marking the Horizontal Measuring Plane

The horizontal plane should bisect important openings.

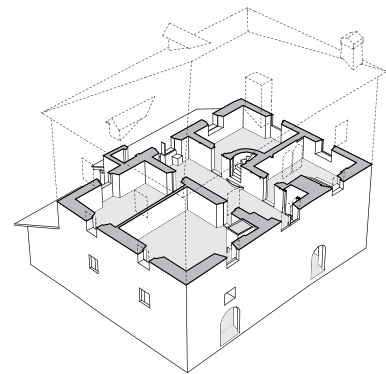
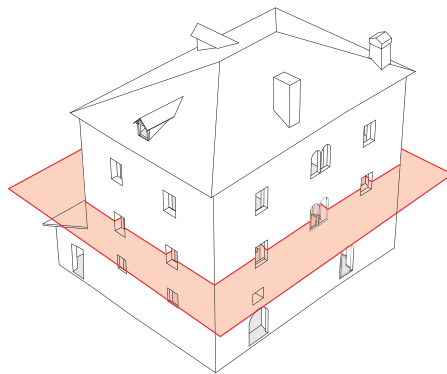

The position of the plane should be neither too high nor too deep, in order to allow for comfortable working.

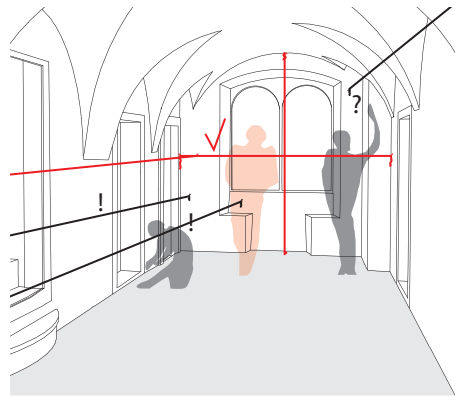

Markings should be reversible and made without causing additional damage. They should be visible for the duration of the measured survey as an orientation guide for mounting the string grid and as a reference point for controlling the height during survey work.

The chosen height is established and kept level throughout the property, irrespective of the ground level, with the help of a laser or optical level (► Chap. D).

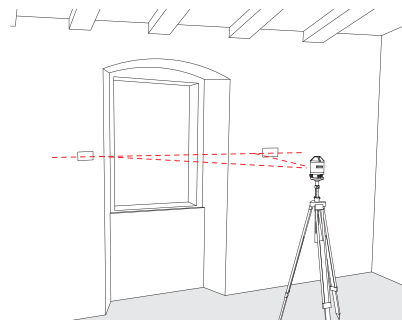

Depending on the property, there are several possible ways to mount the markings, for example with

- pencil marks (small strokes!)
- masking tape (not suitable for surfaces with frames!)
- pins
- small nails
- chalk, paint markers, or oil colors (weather-resistant).

Care should be taken not to add too many marks, but rather to give preference to prominent points, such as corners or window or door openings.

### 2.1.2 Mounting the Horizontal String Grid

The string grid should

- be perfectly horizontal
- be stretched taut
- span the length freely to prevent deviation from its intended position.

The first step is to surround the building with a string grid (“batter boards”), ideally in the form of a closed polygon.

In order to determine the relative position of the string lines while drawing (► Chap. B.3), a string line is extended beyond the point of intersection (x) so that a triangle (x-y-z) can be formed by the addition of another line (y).

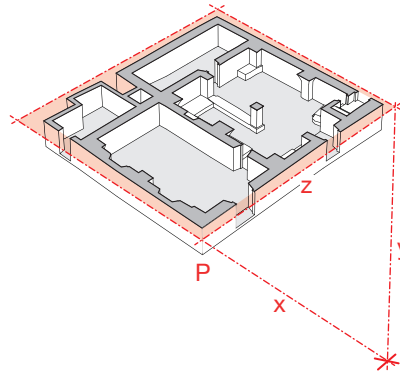

Next, the string grid is affixed inside the property to be measured:

The superordinate system should cover all relevant rooms and should be arranged so that it can be connected with the exterior string grid, for example through any openings in the walls.

In addition, a subordinate network is installed in every room, within which strings are ideally fixed just in front of the wall to be measured. This simplifies later work and allows for greater accuracy.

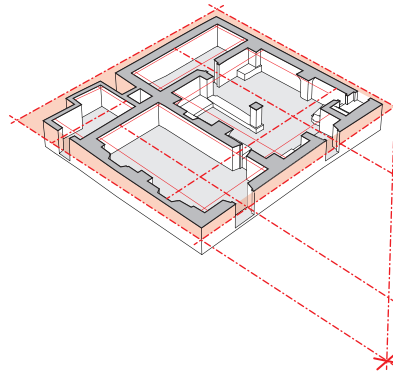

In order to determine the relative position of individual floors, the string grids of each floor should be connected to one another with the aid of at least two plumb lines.

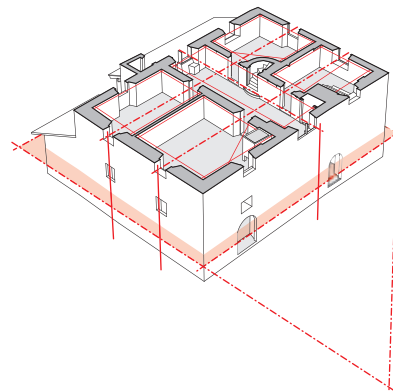

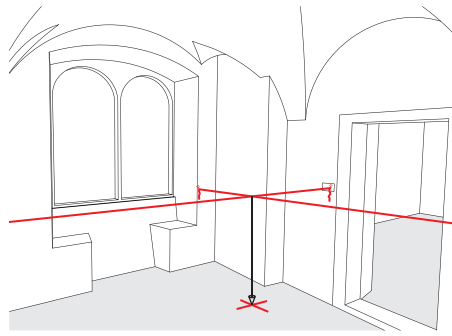

As a precaution, the intersections of the lines should also be checked with the aid of a plumb line and marked on the floor. This should again be checked on the next day and corrected as needed.

In addition, the height of the strings should again be checked during the course of the building survey to ensure that they match with the corresponding benchmarks for height.

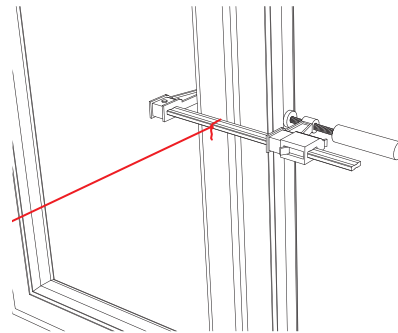

The attachment of the strings should be reversible and should, depending on the nature of the property, be made by causing as little damage as possible.

Batter boards or stakes, for example, can be used in order to mount the strings of the exterior measurement grid. The interior room should offer several options for mounting the strings, for example with smaller nails or pins.

## 2.2 Section and View

### 2.2.1 Establishing and Marking the Measuring Plane

*The sections should intersect important openings and characteristic areas of the property (stairwells, etc.).*

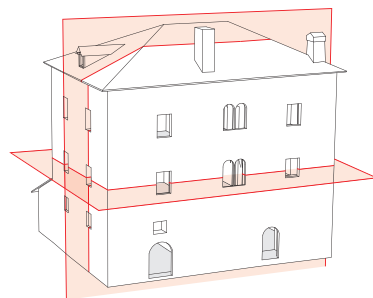

The measurement of sections and views requires both a vertical measuring plane and a horizontal string grid.

Should a floor plan be available, this can also be used to determine the course of the section lines. The location of the start and end points can then be measured from the plan.

The procedure for establishing the horizontal string grid is the same as that for establishing the measuring grid of the floor plan (► p. 20).

Should a measuring grid already be available for the measurement of the floor plan, the height can be copied over from the measuring grid.

The horizontal plane will ideally be positioned in the middle of the ceiling and floor so that the upper and lower boundaries of the room can later be easily reached when measuring.

The marking should be reversible and made without causing unnecessary damage. It should remain visible throughout the course of the survey, as it can serve as a guide when mounting strings or plumb lines or when calibrating the laser, and can also serve as a control for height during the survey.

The markings should be affixed as described on p. 20.

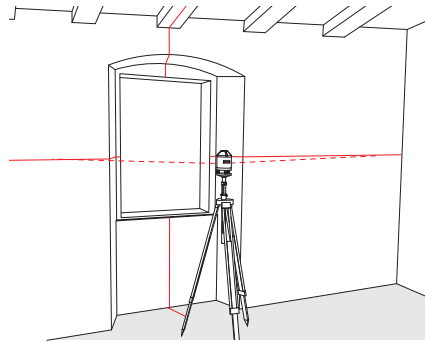

*The established measuring planes are set up and marked with the aid of a laser or level (► the operating procedure described in Chap. D).*

### 2.2.2 Affixing the String Grid to the Marked Heights and the Section Line

The level of the string grid should be precisely horizontal. It should also be spanned taut.

The horizontal main axis should be positioned directly at the height of the section plane. If section views are to be drawn, a horizontal string grid should also be spanned across the walls to be measured for the view drawing. Should a pre-existing measurement grid already be available for measuring the floor plan, this can be carried over and supplemented as needed.

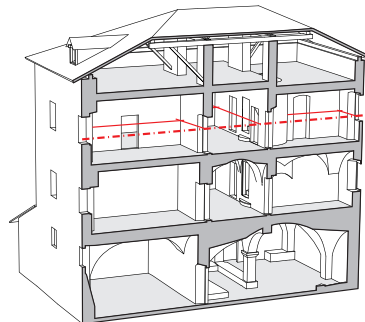

*The string grid used for measuring section views should be mounted just above the surface of the wall to be measured. Should the string rest directly on the wall, it should also be positioned exactly at the predetermined height.*

In addition to the horizontal string grid, plumb lines are also set. The creation of section views requires that these lines be affixed as closely as possible to the walls

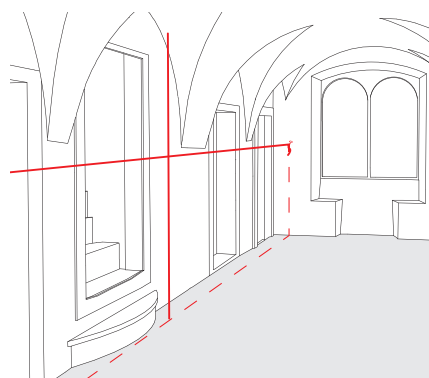



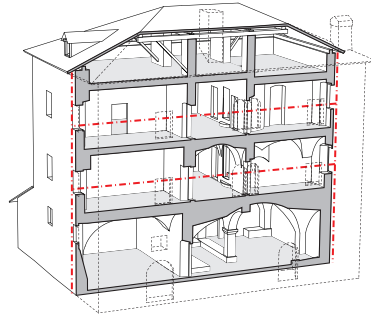

to be measured for the view.

In order to determine the relative position of several floors to one another, a plumb line should be established which connects the individual horizontal planes (string grids) to each other, either on the exterior of the building or through any continuous openings in the floors.

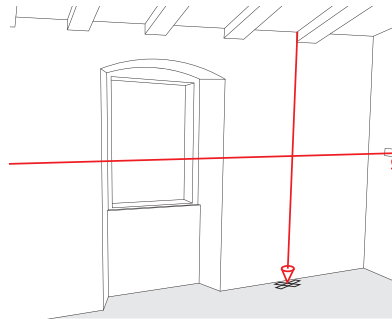

As a precaution, the position of the plumb lines should be marked on the floor. These marks can subsequently be checked on the next day and corrected if necessary. In addition, the height of the horizontal strings should be checked during the course of the building survey to determine whether it still corresponds to the height markings.

On affixing the strings, see the floor plan (► p. 20).

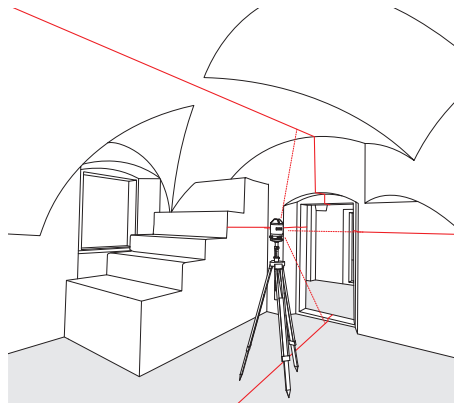

Instead of a string grid, a laser level can also be used to measure sections and views. The laser level, which indicates horizontal as well as vertical planes, is positioned at a fixed point for the duration of the survey in front of the wall to be measured. (► Chap. C.2).

In order to position the laser level consistently at a precise location, it is important to mark the established course of the section line as well as the height of the horizontal plane (► p. 20).

### 3. Calibration and Transfer of the Measurement Grid

**Before calibrating the measurement grid:**

- Estimate the size of the property at the predetermined scale and then establish its approximate location on the sheet (of film or paper).
- In case several sheets are needed, enter control points.
- Draw in the scale bar (► Chap. G.1).

#### 3.1 Floor Plan

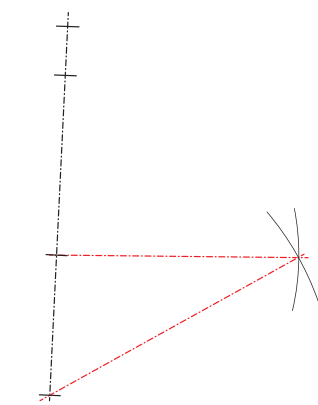
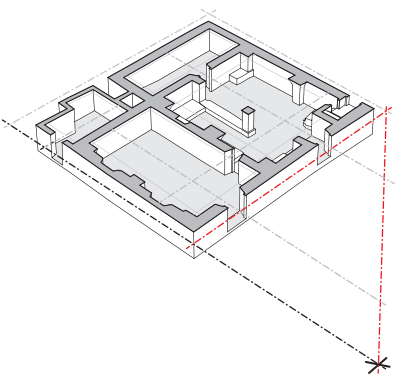
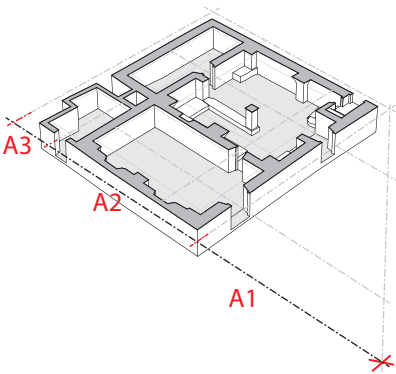
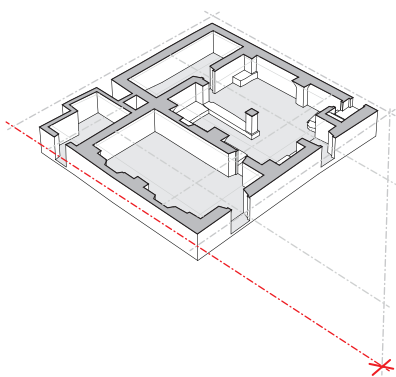

Measure the length of the first string. Draw the measuring tape taut and transfer the measurements.

Take note of the “0”-point of the measuring tapes! Measure longer stretches twice (from both sides) in order to avoid reading errors.

If multiple measuring tapes or folding rules are being used, check if all are marked at the same scale.

Measure in and transfer the intersections.

The strings are never stretched at a perfect right angle to one another. Their exact position thus has to be determined. For this purpose, the individual strings which form the triangle need to be measured, their lengths are then entered onto the sheet with the aid of a compass.

The points of overlap of the arcs drawn with the compass are then connected with the intersections, the resulting straight lines represent the other strings.

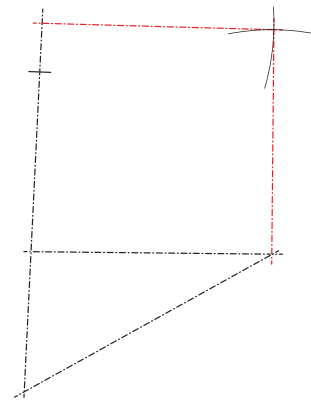
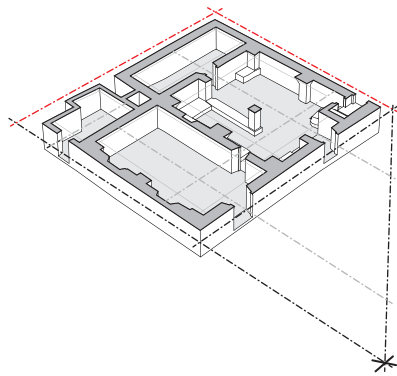

Measure and transfer the intersections of the interior and exterior grid. Measure the lengths of the strings and transfer these onto the drawing.

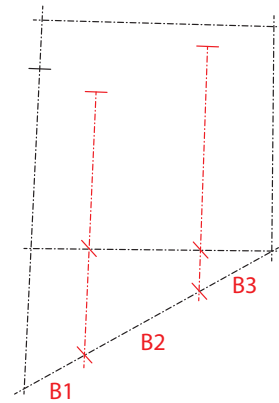
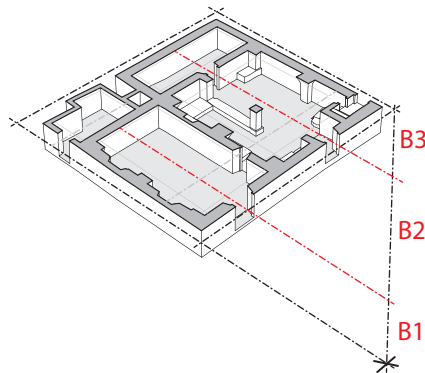

The strings of the interior measuring system are then transferred onto the drawing with the help of triangulation.

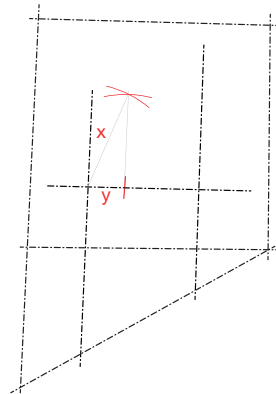
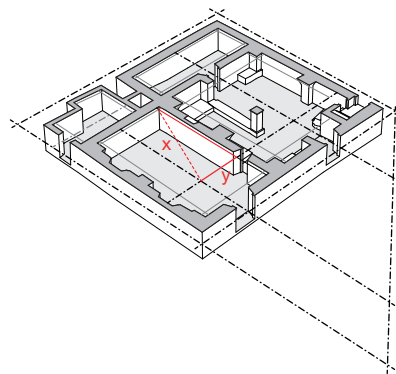

Triangles:

- Only measure the lengths, no additional strings need to be spanned (distance x).
- Aim for a greater degree of accuracy by avoiding acute angles!

Following this procedure, measure the strings on all floors until the measuring grid is complete and transferred in its entirety onto the drawing.

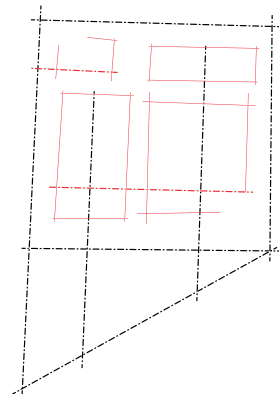
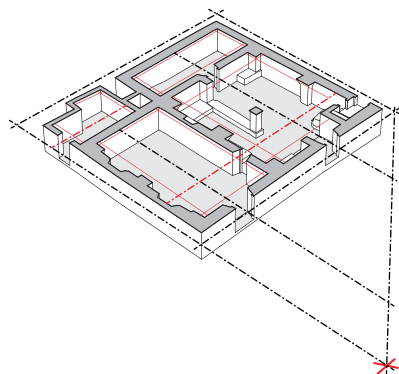

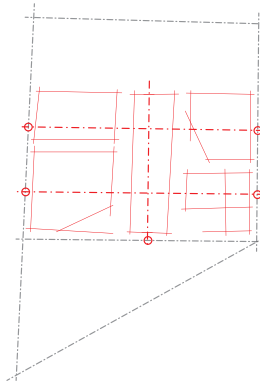
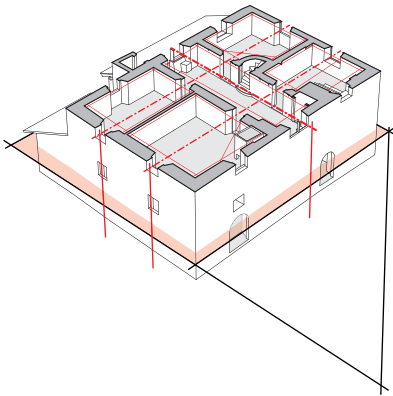

The relative position of the individual floors can be determined by using the previously established plumb lines (► p. 21).

### 3.2 Section and View

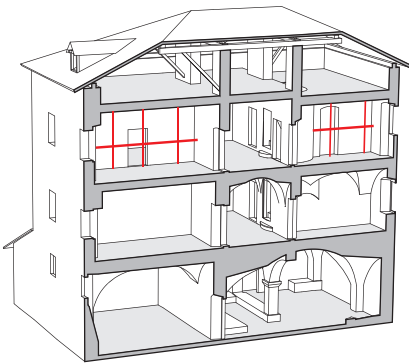

Measure the length of the first string. Draw the measuring tape taut and transfer the measurement (on avoiding reading errors, ► p. 25).



Measure and transfer the intersections of the horizontal lines and the plumb lines.

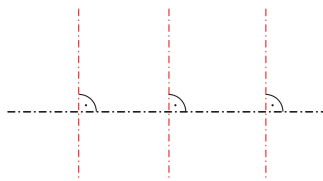

Transfer the plumb lines onto the drawing.

## 4. Measurement and Drawing

### Practical Tips:

- Divide the rooms to be measured among the team members. Each member should both measure and draw; the grid may be established together.
- Always measure directly on site.
- Always set up work directly in front of the section on which work is currently being carried out.
- Room corners, window and door frames, and other prominent points should be measured, additional points can also be determined over longer sections of wall.
- Edges, top views (for example floor structures), bottom views (reflected ceiling plans, ceiling beams or joists, arches, vaults), section views, and concealed edges should be drawn.
- Surface structures of wood, stone, stucco, etc. should also be depicted (on accuracy in portrayals, ► Chap. G.1).
- Areas which cannot be measured or reconstructions should be clearly marked as such on the drawing.

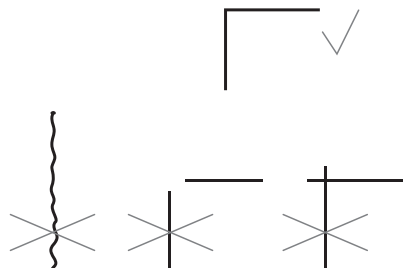

Avoid drawing with squiggly lines. The ends of the lines should converge to a point. It is also theoretically possible to draw directly on a PC.

Further information on presentation can be found in ► Chap. G.1.

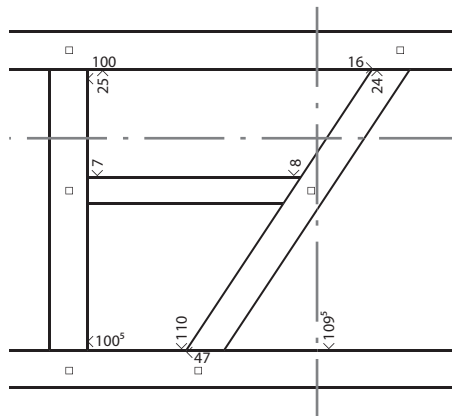

### Indicating Dimensions:

Labels should be written in the direction of measurement. Measured points are indicated with arrows (only main measurements).

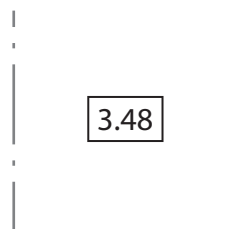

The distance between two axes of measurement should be indicated, the measurement entered into a box.

For the finished drawing of a measured survey, ► pp. 52 ff.

#### 4.1 Floor Plan

Always measure at least two coordinates on the horizontal plane per point.

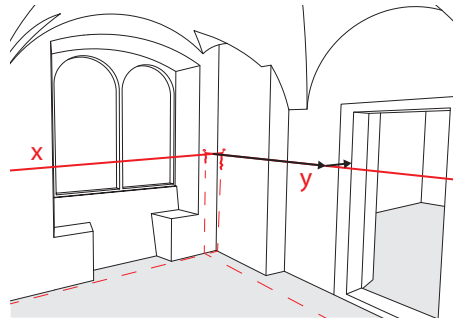

Determine the distance at a right angle between the point to be measured and the string by using the swivel method:  
The smallest value corresponds to the distance which meets the string at a right angle.

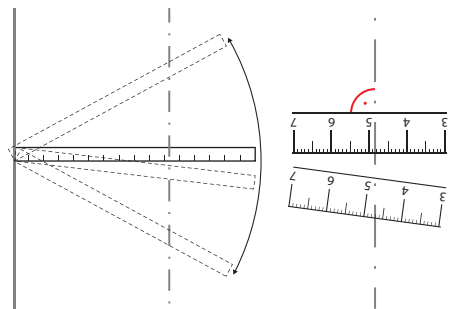

Measure longer distances with the aid of a corner square or triangle.

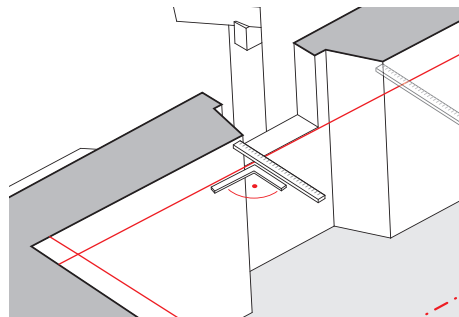

The point x can be marked on the string with tape.

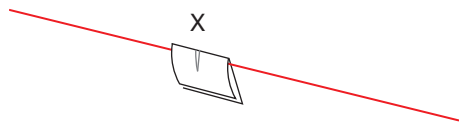

Measure the distance from point x, marked on the tape, to the zero-point or intersection.

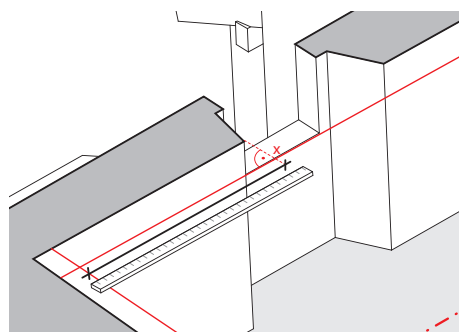

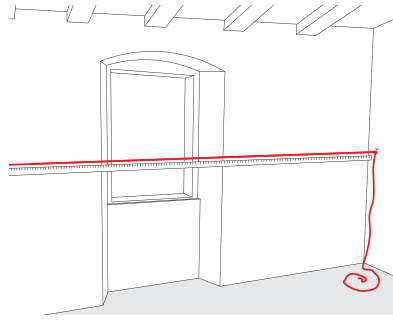

It is also possible to stretch a measuring tape in front of the string line for a longer time, from which the values can be read directly.

If the “0”-point of the measuring tape is not the same as the “0”-point of the string line, the discrepancy should be accounted for during measurement.

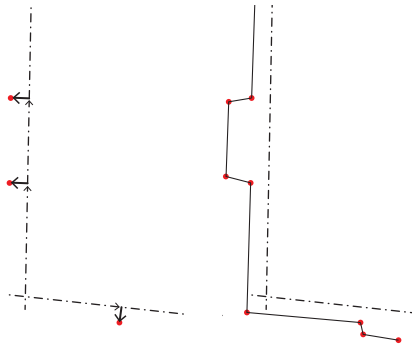

Transfer the measured points onto the drawing and connect them together (if necessary, first lightly sketch the line with a ruler and then retrace by hand).

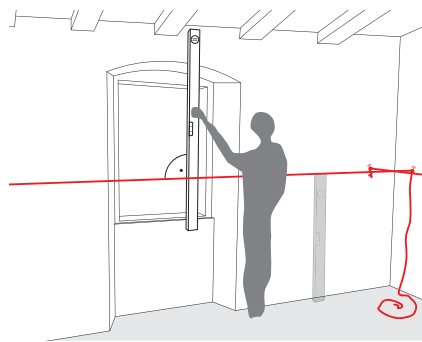

Points above or below the measuring plane (reflected ceiling plans, floor) should be plumbed down or up, respectively, ideally by using a long spirit level.

## 4.2 Section and View

Measure from the horizontal string and from the plumb line at a right angle to the respective point.

This can also be done most easily by using the swivel method (► p. 29).

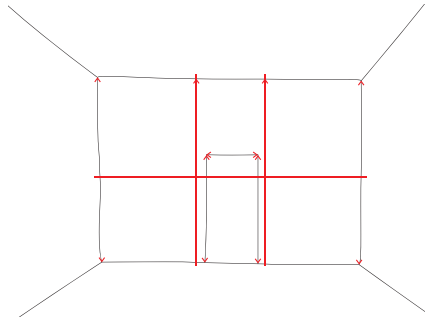

Transfer the measured points onto the drawing and connect them (if necessary, first lightly sketch the line with a ruler and then retrace by hand).

In order to measure the height of the individual points to the horizontal, a spirit level (with a measuring scale) can also be used instead of a plumb line.

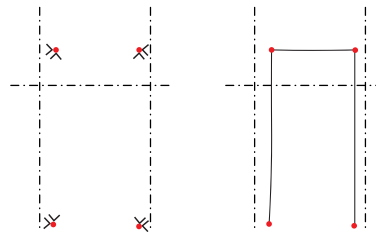



**Special Case:**

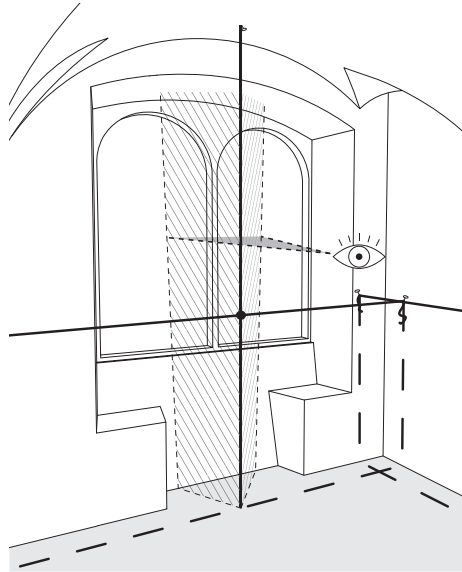

If the areas which need to be recorded for a section view do not all lie on a single plane, for example in the case of window recesses or alcoves or in the case of surfaces with raised wall reliefs, etc., a single plumb line will no longer be sufficient for the measurement of the vertical plane. The spatial depth of the features precludes an exact determination of the position of the points in the rear plane with respect to the plumb line.

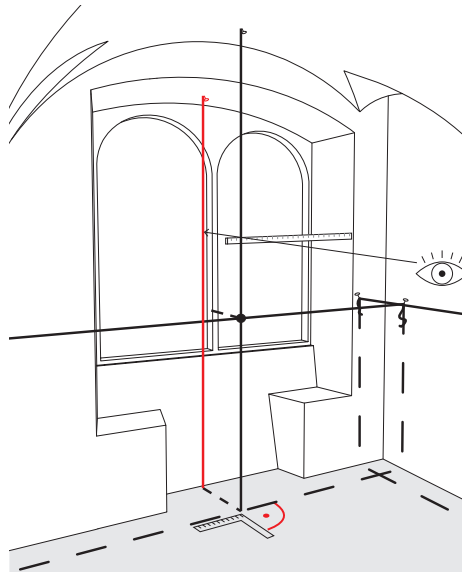

A second plumb line must thus be used to mark another plane vertical to the projection plane (view plane).

With the aid of a long tee-square, a straight line is drawn through the point of the first plumb line to the projection plane (view plane). The second plumb line is affixed directly above this straight line.

All measurements of the rear plane needed for the view drawing can now be recorded by taking bearings by means of the two plumb lines (these should overlap exactly, that is, appear to the observer as a single line).

## 5. Details

It is useful to install a separate measuring system for the measurement of details, for example of architectural components or interior fixtures.

This system similarly consists of a horizontal and a vertical plane and can, for example, be established with the aid of a tee-square.

In order to simplify the process of measuring, a measuring scale is attached to the tee-square.

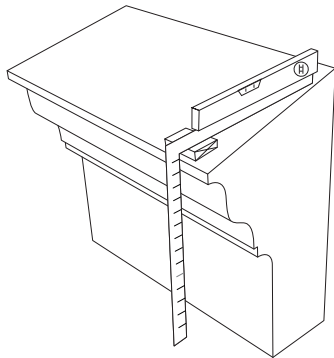
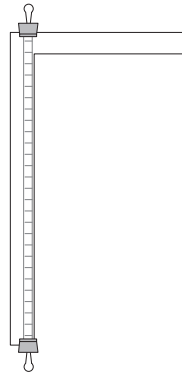

*If the detail is fixed and built into the room to be measured, the measuring system must be established precisely horizontally and vertically so that it can link into the measuring grid of the respective room.*

*The measuring system is transferred onto the drawing sheet.*

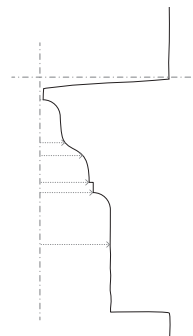
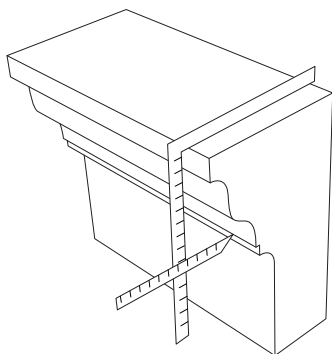

*With the aid of a second ruler, all horizontal values relevant to the profile drawing can be taken by measurement and transferred to the drawing. If the ruler has a sharp end, the necessary points can be measured very precisely!*

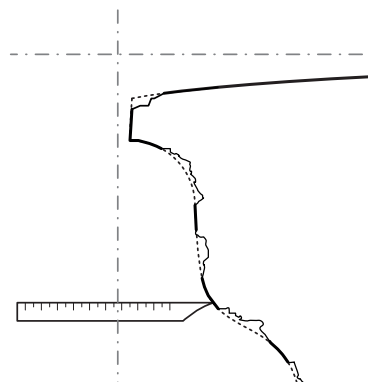

*If the building component is heavily weathered, measurements are taken from the unweathered parts. The profile established in this way can then be checked if necessary by a pattern gauge.*



*Historic theodolite (Hildebrand Company, Freiberg i.S.), ca. 1890.*

# Optical and Visual Aids

**Before using any instruments or aids:**

- As a basic principle, always calibrate the instrument first. The instrument may have been affected during transportation or through any impact and should absolutely be corrected before being used. Otherwise, errors may creep into the measurements from the beginning which may be impossible to correct later.
- In order to test the instrument, it should be set up and positioned, a test measurement should be taken and marked. Afterwards, the instrument should be re-positioned and the same measurement taken and checked to ensure the same result.

## 1. Optical Level

Mode of Operation:

An optical level (or simply “level”) can be used to locate any points at the same height or on the same horizontal plane.

Before use, the level is mounted on a tripod. The circular bubble is used to calibrate the optical level, that is, to ensure an absolutely horizontal position. The attached compensator can be used to fine-tune the levelling. The optical level always has an eyepiece with an optical lens, which normally contains cross-hairs and sometimes also stadia lines. The horizontal line of the cross-hairs represents the horizontal plane.

Some instruments also have a built-in protractor or other mechanism to measure horizontal angles, which allow for other operations such as the measurement of points on the floor plan (► Chap. C.3).

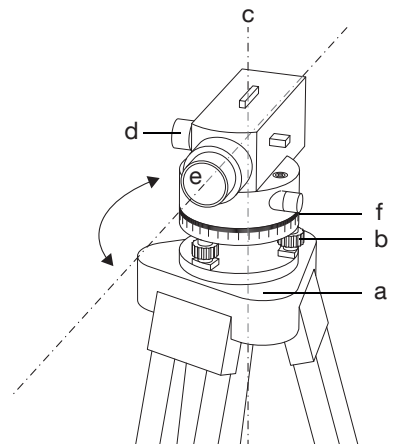

Set up and components of an optical level:

- a) tripod mount
- b) leveling screw and circular bubble
- c) axis of rotation
- d) focusing knob for fine-tuning position
- e) optical lens with ring for focus adjustment
- f) on some models, 360° protractor

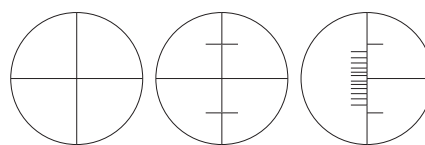

View through the lens:

- a) cross-hair or reticle
- b) additional vertical hairs
- c) graduated reticle

Applications

- **Measuring heights / leveling:** Points can easily be “leveled”, that is, their relative position can be determined even when they are separated by large distances. For this purpose, the plumb-vertical distance has to be established from the point to be measured to the horizontal plane by taking bearings. The difference in height results from the addition or subtraction of the two values. If an absolute height value has been established, the heights of all other points can be established by referring to the differential between them and this absolute value.

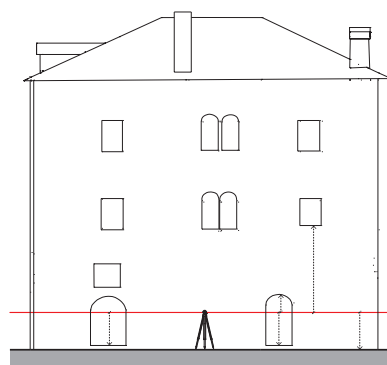

Measuring height with the aid of a level: the reference is always the horizontal plane established by the level, as determined by the height of the optical lens.

*Establishing the exterior measuring grid by taking bearings through the optical level.*

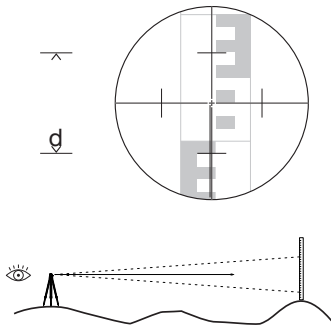
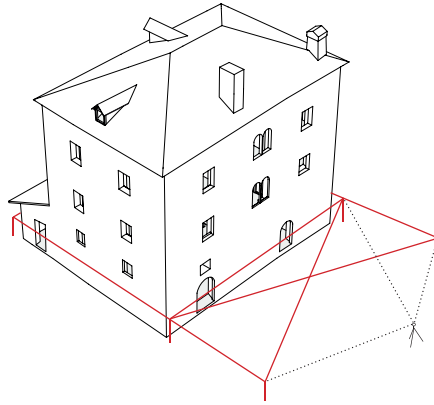

- **Establishing a measuring grid:** The measurement of the outer shell of a building requires string grids with greater lengths which are stretched horizontally in front of the walls. In order to establish a truly horizontal measuring system, the points at which the strings are affixed can be located and calibrated even at greater distances with the aid of the optical level. In contrast to a laser level, this method does not depend on available light.

- **Measuring distances:** The vertical hairs, which are usually affixed to the inner side of the eyepiece (above and below the cross-hair) can be used to take readings from a measuring staff at the target point. The distance  $d$  between both hairs, multiplied by 100, yields the actual distance to the target. This method is limited in accuracy and is commonly used only in land surveying.

**Practical Tips:**

- Take particular care in using the circular bubble when setting up the instrument! A flawed horizontal position can quickly lead to large errors in measurements.
- When looking through the eyepiece, make sure to take readings from the center cross-hair, and not from the vertical hairs!
- If there is any doubt, readings should always be checked from two separate instrument locations.
- If the instrument is moved or jostled, repeat the steps for establishing a horizontal position! It is impossible to recover the exact previous location.

## 2. Laser

### Operating Procedures

A horizontal laser level emits one, a cross-line laser two or three vertically upright laser planes onto the surrounded surfaces (walls, ceilings, floors, etc.), depending on the functional range of the instrument. The planes are reflected on every surface they touch as vertical or horizontal lines. Since not every instrument can reach the maximum angle of projection of the laser lines of 360°, it may be necessary to reposition or rotate the device frequently.

The instrument should ideally be mounted onto a tripod, but may, if the spatial situation demands, also be set up directly on a surface. The instruments are usually equipped with a compensator which allows for a fine-tuning of the horizontal position. This means that the circular bubble on the device is used only for rough positioning during initial set up. The range of functions, number of axes, thickness of the laser beam, and other features can vary widely among the numerous models currently available, depending on quality and cost.

If the instrument is used outdoors, particularly under bright sunlight, the laser lines may be difficult or even impossible to recognize. In these cases, a manual receiver (f) may help to recognize the laser signal and display the correct height on the screen. Looking directly into the laser beam should definitely be avoided, special safety goggles (e) should be worn during operation.

### Applications

- **As a replacement for a string grid:** It is often difficult to establish a measuring grid using string lines without causing additional damages, especially in properties which are still inhabited or on delicate surfaces, such as those containing wall paintings. A rotation laser may be useful here, since it can be used to establish an independent measuring grid. The projected lines are particularly useful for creating view drawings or sections, since the resulting cross-line can replace both the plumb line and horizontal string lines.

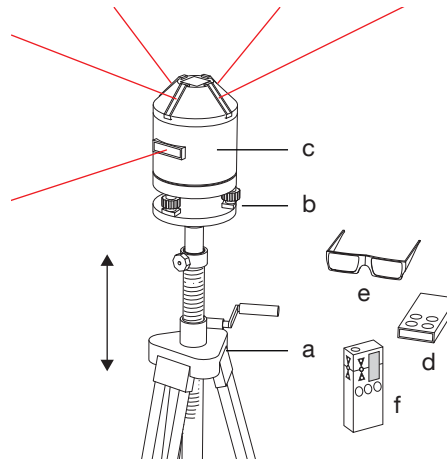

*Components of a laser instrument:*

- a) tripod mount (crank tripod)
- b) leveling screw with adjustable feet and circular bubble
- c) laser instrument with multiple axes
- d) remote control
- e) safety goggles
- f) manual receiver

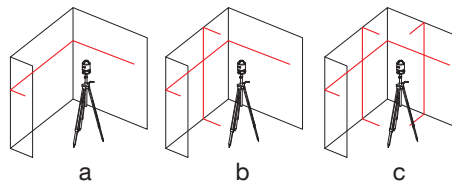

*Varieties of laser levels with various functional ranges:*

- a) horizontal laser
- b) cross-line laser (2 axes)
- c) cross-line laser (3 axes)

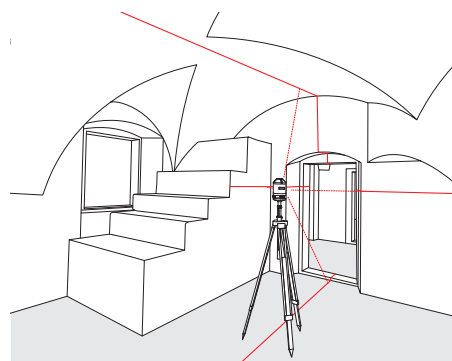

*Cross-lines of a laser level projected onto the surfaces of a room. A laser beam is unable to project onto undercut surfaces.*

*Laser lines projected onto a wall, floor, and ceiling: these can be helpful when measuring with a tachymeter, particularly for curved surfaces.*

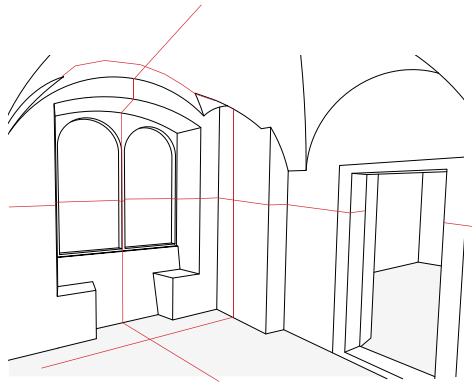

*Transfer of the height of the measuring plane across several rooms, for example with the help of a door frame.*

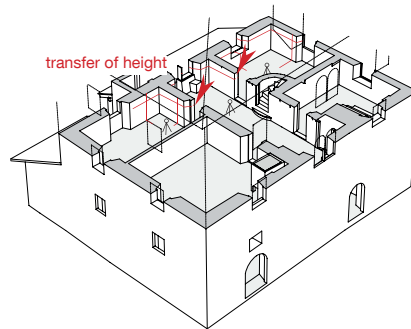

- **Displaying the measuring plane:** Particularly when measurements are to be taken with an electronic instrument such as a tachymeter (► Chap. E.1), the laser level can be used to project the measuring plane onto walls, ceilings, etc. That is, the laser serves as a visual aid for tasks such as marking points at the same height for a floor plan. Particularly when working with complex geometries (curves, vaulting), the naked eye alone is seldom reliable when taking bearings.

- **Repositioning an instrument:** Once the second half of a room needs to be measured, the laser level can usually be simply rotated 180° on the tripod. If, however, measurements require a change of location (for example, into another room), it becomes necessary to display the height previously used at a point visible from both locations (for example at a door frame). The use of a crank tripod can help to establish the correct height.

#### **Practical Tips:**

- As a precaution, the position of the laser beams on surfaces should always be marked separately as well (for example, with a pencil)! This allows for the measuring plane to be identified and maintained even when the work is carried out over the span of several days or if the instrument should break down.
- But: No markings (pencil, tape, nails, etc.) should be made on delicate surfaces!
- The vertical position of the instrument should always be checked! In particular, inexpensive instruments can produce inaccurate results. Similar errors may arise if the laser level is upset or falls down. For this purpose, the height should be marked on the wall and checked with a reading from another instrument location!
- Wear safety goggles! Other persons in the area should be made aware that the device is currently in operation, for example by posting signs on nearby doorways, etc.
- Make sure to maintain a supply of replacement batteries for the instrument and for the remote control!

### 3. Theodolite

#### Mode of Operation

Though the layout of a theodolite is similar to that of a level, the device is also provided with a vertical tilt axis, which allows for the measurement of an additional angle. The theodolite can thus measure angles both horizontally and vertically.

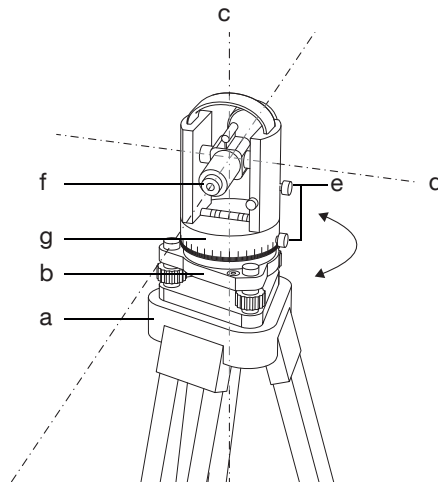

*Layout and components of a theodolite:*

- a) tripod mount
- b) leveling screws and circular bubble
- c) rotation axis
- d) tilt axis
- e) focusing knob for fine-tuning position
- f) eyepiece and lens with fine-adjustment
- g) protractor and tangent screws for changing azimuth (horizontal and vertical)

#### Applications

Theodolites can be used for the same purposes as optical levels, since they also cover the same functions. Since, however, they are also able to take measurements on a vertical plane, they offer a range of other possible uses, all of which pertain to the location of points in space. The basic techniques are the measurement of distance (► Chap. C.1) and the measurement of angles or the definition of azimuth.

- **Measuring angles or determining direction:** Beginning at the instrument location, a straight line is determined which extends to a fixed point  $x$ . The line is set as the “grade line” or “zero line” of the instrument. The position of additional points to be taken can now be measured in relation to this line based on the angle indicated on the instrument.

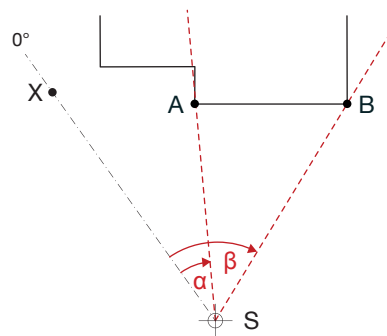

- **Polar measurement:** If the measurement of angles, as described above, is combined with the measurement of distances, as, for example, with the vertical hairs of the optical lens, the floor plan can be measured rather quickly. In order to determine the position of a point, the corresponding azimuth is read from the instrument and entered onto the recording sheet as a line. The established distance is then marked onto the straight lines.

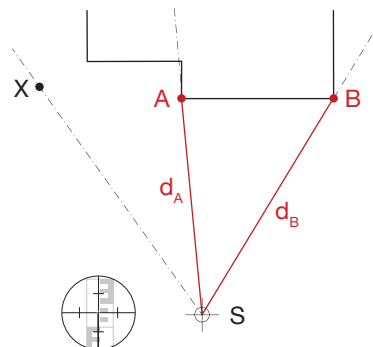



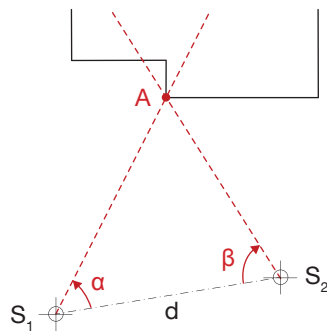

- **Intersection:** Another application is possible if two theodolites are available. Once the distance between the two has been established, they can be used to determine directions from the respective location of the instruments based on the measurement of angles described above. The location of the other instrument serves as the fixed point for the measurement. The intersection of the triangle formed by the angles measured from both instruments indicates the location of the desired point. This method thus does not require a distance measurement and is consequently more accurate.

*Determination of the position of a point in space with the aid of a tachymeter. The position is derived from the horizontal and vertical angles as well as the absolute distance.*

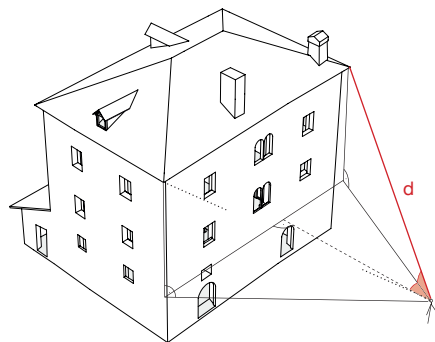

#### Outlook: Tachymeter

A standard theodolite does not have any mechanisms for precisely measuring distances. This capability can be added to some instruments through attachments. A theodolite capable of measuring distances is referred to as a tachymeter (► Chap. D.2).

This expanded functionality makes it possible to provide an exact position for a point in space with respect to its horizontal and vertical angles and its exact distance from the instrument. The effort and amount of time required for calculation and construction are accordingly great. In modern tachymeters, these calculations are performed automatically by the instrument itself, which can also be connected directly to a computer. This combination is referred to as a total station, with which it is possible to check the measurement on site on the display and to recognize any errors immediately.

The high degree of efficiency of modern total stations has led to the wide-scale abandonment of classical theodolites. Theodolites are still used occasionally in the construction trade, though even these have been augmented with useful digital capabilities.

# Electronic Building Surveys

## 1. Properties

It is impossible to state unequivocally which method of building survey – manual or electronic – is particularly suited for a particular property. Instead, persons in charge of the survey have to make this decision themselves based on the character and condition of the property and based on their own prior knowledge and abilities. There are, however, some guidelines which might help in choosing the right method.

Electronic surveys using a tachymeter are linked to processing the data in CAD-software. In contrast to a manual survey, the measuring grid can be established without too many complications – the electronic measuring grid is established through reference points – and thus saves both time and effort.

A great advantage of electronic building surveys is derived from the possibility of taking measurements with great precision even across larger distances. This allows even larger room complexes, buildings, or other properties to be measured and surveyed efficiently and quickly while still maintaining a high degree of accuracy. While the measurements of a manual sur-

vey always have to be taken at the measured point, an electronic survey allows for numerous points to be measured from a few, even quite distant locations. This is all the more important if the building property is even partly inaccessible. While the manual measurement of larger facades, roof constructions, etc. can only be carried out from scaffolding or a ladder, electronic surveys can be conducted with the aid of a tachymeter from the ground.

Conversely, working off the instrument location prevents a close examination of the property during measurement. In contrast to a manual survey, detailed study of the building is carried out separately from the actual survey measurement.

The opportunity for incorporating interpretations of observed findings into the plan drawing or for portraying particular areas (traces of prior construction, surface structures, broken or plastered edges) is also made much more difficult by the use of CAD-software. A practical solution is to map these details manually on printed plans on site and incorporate them into the digital drawing afterwards as needed.

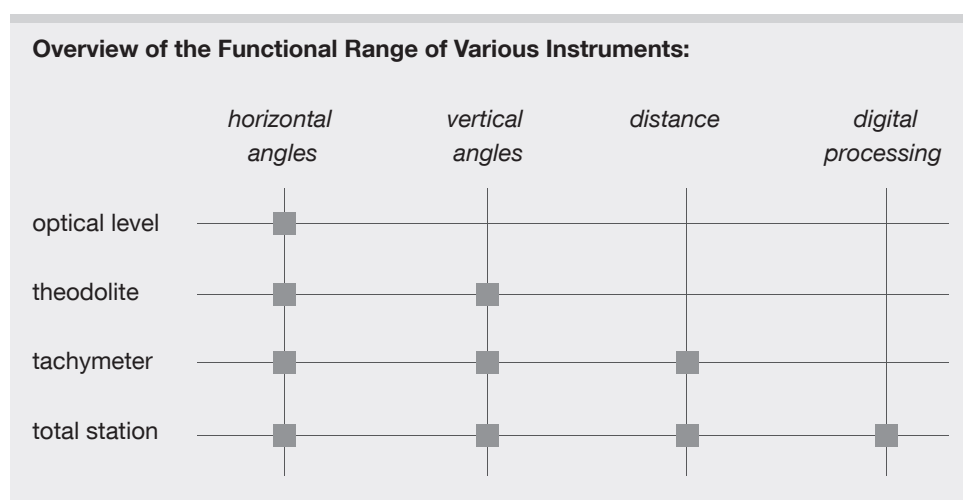

Total station, consisting of a tachymeter and a connected laptop.

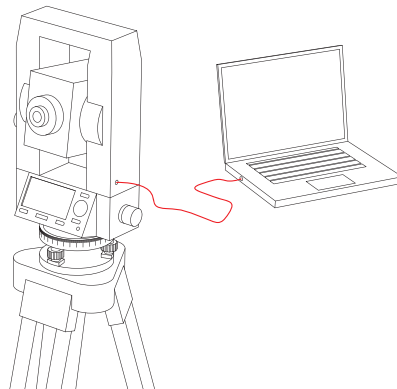

**List of Required Materials:** tachymeter, tripod, drawing board, laptop with CAD-based measurement software attachment, spotlight, cable drum, folding rule, measuring tape, flashlight, measuring points and mounting material (glue, masking tape, nails...)  
*In addition, as needed:* sketch book, ladder, camera, cross-line laser level, compass

Independent spatial measuring grid: the measured points are each assigned x-, y-, and z-coordinates.

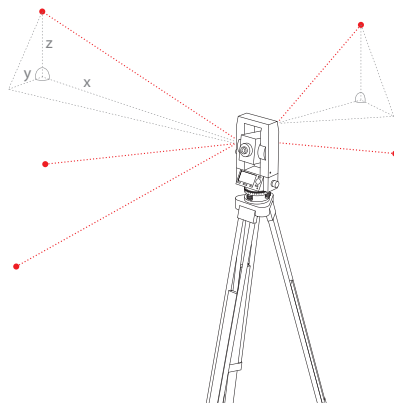

## 2. Tachymeter/Total Station

### 2.1 Mode of Operation

As already described (► Chap. C.3), a tachymeter is essentially a theodolite with the additional capability of measuring distance. A tachymeter emits a beam of light which is reflected back from a target point. Based on distance and angle, the instrument calculates the coordinates of the target point with respect to the location of the instrument.

The combination of tachymeter and laptop is referred to as a total station. Information from measurements is displayed immediately on the screen. The data can be transferred either by cable or (if the instrument is so equipped) by bluetooth.

### 2.2 Material

In contrast to a manual survey, measurement with the aid of a tachymeter requires electricity. The run-time of a laptop and particularly of the tachymeter is limited to a few hours. In order to charge the batteries and thus guarantee a smooth work flow, basic care should be taken beforehand to make sure that a source of electricity will be available on site. To some extent, adapters can also be found which make use of commercially available batteries.

### 2.3 Procedure

The goal of measurement with a tachymeter is the same as that when the survey is carried out manually: to establish an independent measuring system. This system, however, is not created by stretching a string grid, but through individually defined spatial points. When these are measured using a tachymeter, they are also assigned x-, y-, and z-coordinates. These so-called reference points serve as basis for a distinct coordinate system.

### 2.3.1 Preparatory Tasks

#### Measuring Grid

The first step is always to gain an exact overview of the property to be measured. This step includes a first tour of the site and sketches of the floor plan and any important details. A prudent choice of location and measurement always requires at least a rough acquaintance with the building. The measurement of larger properties in particular requires prior deliberation on how the survey will proceed in order to gain as much information as possible efficiently with the fewest number of stations. The first decision to be made is how many floor plans, sections, and views will be measured, where the section planes are to be drawn, and, if possible, what scale is required. Based on these decisions, the station points of the tachymeter can already be entered onto the preliminary sketches.

The goal of these decisions is to let as many measurements be taken from a single station point as possible, since repositioning the tachymeter always takes time. Furthermore, it should be considered that not all floor surfaces may be suitable for positioning the instrument or that doing so may entail additional problems. This can particularly be the case in attics or other roof structures or in rooms with wooden flooring, where even small vibrations may impair the calibration of the instruments. This too should be considered when choosing the station point.

#### Software

The next step is to configure the required software in such a way as to permit a smooth workflow, by which all information gained through measurement can later be matched to the respective location. It is not always possible to revisit a property later.

It is helpful to use the layer structure of the software program and thus to create

several layers. In general, there is no such thing as a uniform standard which defines the criteria for organizing these layers. Care should always, however, be taken to ensure that, depending on the project, other team members working on the site are able to understand and work with the resulting data.

A helpful organization of the files can, for example, include a distinction between transected areas and surface views. Even a classification according to parts of the building, materials, or surfaces can be a useful aid in orientation.

### 2.3.2 Positioning

Positioning refers to the location of the tachymeter within a coordinate system, either pre-defined or, if the first station is being set up, still to be defined.

Positioning requires so-called control points or reference points, which are fixed in a room and measured with the help of the instrument.

#### Procedure

Based on the preliminary plans, the first station point of the tachymeter can now be established. The tripod is set up as straight as possible and the tachymeter mounted on the screw of the tripod head. In this step, the tripod should be roughly aligned. The laptop is connected directly to the tachymeter through a USB-cable. Next, the instrument should be precisely set to level in order to ensure accuracy during measurement. For this purpose, two circular bubbles are attached to the outside of the instrument. The final, precise fine-adjustment of the position can rely on an electronic level built into the instrument, which appears when the device is first switched on. Adjustments can be made with the help of three small wheels. If the tachymeter is not placed in a precisely horizontal position, any measurements taken will always be inaccurate!

The instrument includes circular bubbles which are used to give a rough levelling to the tachymeter. Fine adjustments are made using the built-in digital level. Adjustments can be made with the instrument's adjusting screws.

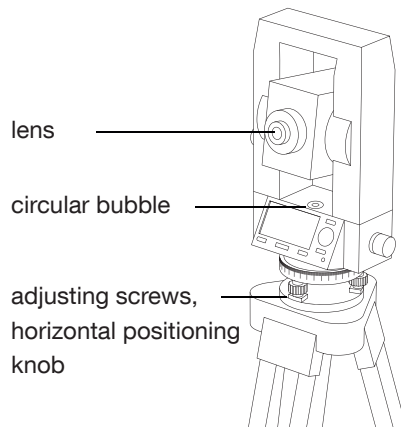

**Attention:** There is a danger that the tachymeter may become misaligned through vibrations of wooden floors or timber roofs or through other irregularities. The process of positioning should thus be repeated every time from the start. It is not possible to simply re-align the instrument by using the spirit level and to continue measurement without repositioning. This will inevitably lead to inaccuracies in measurements!



Control Points

Next, all control points need to be mounted at their locations. In general, these consist of cross-hairs printed on paper. These are assigned and labeled with individual numbers so that they can later be easily matched with the corresponding point on the laptop. Other prominent points or objects in the room (for example, the heads of screws), may, however, also be used as control points. This is sometimes necessary, particularly when the control points are needed at great heights or when paper control points cannot be mounted onto a particularly delicate surface.

Care should be taken that the points on the one hand are easy to find, and, on the other, that they are not too large, since this too can lead to inaccuracies in measurement.

The distribution of control points in the room falls under the responsibility of the respective surveyor and should be decided based on the following criteria:

- The choice of different directions and heights (wall, floor, ceiling).
- Points should not be mounted onto movable objects.
- Control points should be distributed so that at least some of them can also be located from other station points. Care should be taken to place control points in all relevant areas.

Control point, printed on paper, to be attached to the object measured.

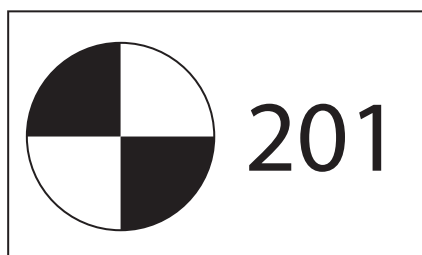

**Attention:** Control points cannot be mounted onto all surfaces. In certain circumstances, they may have to be attached using a different method, in others, attaching control points to particular areas (such as wall paintings) should be avoided.

### Measuring Control Points

In the next step, the mounted control points should be measured with the tachymeter in order to assign individual coordinates to each. These points together constitute the individual measuring grid established for the property. During the course of work, as many control points can be added as needed or desired.

In order to measure the control point, the point should first be located with the instrument. This first step can be carried out roughly using the laser beam. The precise fine-adjustment is then carried out using the lens: looking through the eyepiece, one should also see the cross-hairs. These should cover the mounted control point exactly.

All further commands should be coordinated between the CAD-software and the measurement-attachment. The points can be displayed directly on screen and checked for accuracy.

After these steps are completed, the proper work of the measured survey can begin.

### Repositioning

Multiple station points are necessary in order to measure all of the information required. For this purpose, the instrument is taken down and mounted onto the tripod again at another location and connected again to the laptop. Just as was the case with the first positioning, the repositioning of the tachymeter requires that the instrument again be set to level.

After the instrument is brought into horizontal alignment, it should be sufficient to measure three known points (if possible, in different directions and with different heights) in order to orient the measuring system again within the grid.

Once these points have been measured and the location of the instrument is defined, additional control points can again be measured, for example in areas or rooms which were not visible before. Otherwise, the measured survey proper can continue.

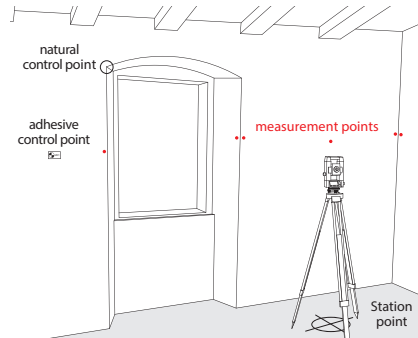

*Control points and measurement points in a room.*

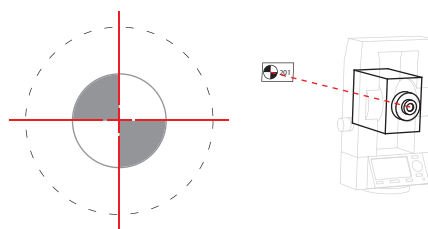

*When looking through the lens, the cross-hairs of the instrument and the cross-hairs of the control point should be in exact alignment.*

**Step 1:**  
Set up of the instrument and measurement of the first control points.

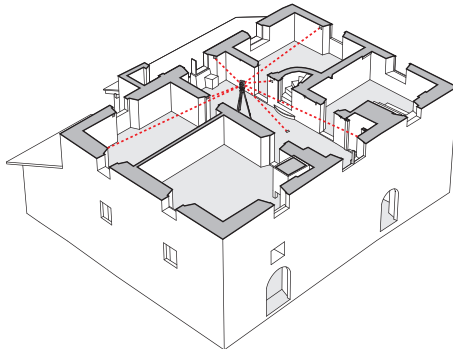

**Step 2:**  
Measurement of all points required for the floor plan, view, and section.

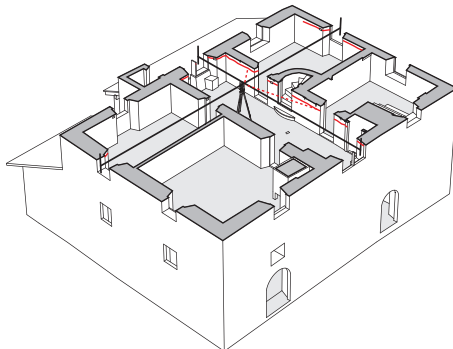

**Step 3:**  
Repositioning of the tachymeter and calibration into the system based on at least three known control points.

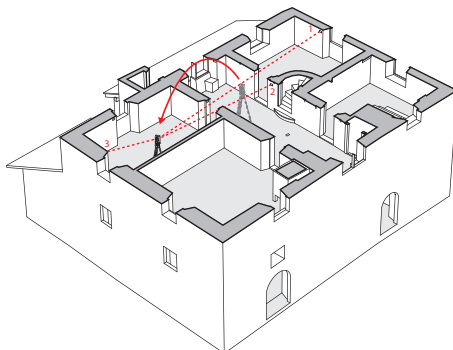

**Step 4:**  
Continued measurement of the floor plan, view, and section.

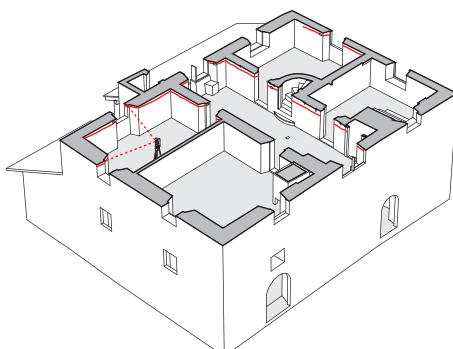

### 2.3.3 Measurement

#### Preparatory Steps

Ideally, the course of the section lines should have been established previously. As a visual aid, these can be marked with the help of a laser level (► Chap. C.2) or with strings mounted on the building. Before the actual measurement begins, the level of accuracy and detail which will be required by later plan drawings should be clear. The scale should be chosen accordingly. This information also determines the accuracy of the measurements. The number of points which need to be measured also depends on the condition of the building. For example, a wall which has suffered from a great degree of deformation demands more points than a wall which has apparently retained its shape.

#### How to Measure

The point is located with the laser beam or through the lens, the measurement is then triggered either on the instrument itself or in the software installed on the laptop. Since, as previously stated, measurement depends on the principle of laser reflection, there may be surfaces which are either unsuited or only poorly suited for this type of measurement. Problems can arise with dark surfaces or glass, where the light beam will break. In these cases, a piece of paper can be held over the spot where the point is to be measured or a measuring prism can be used instead.

#### What to Measure

Measurements are to be taken for all parts of the building, surfaces, constructions, and fixtures, bearings for which can be taken either with the laser or the optical lens from a particular station point. It is important that no objects break the light beam, since this disruption would lead to errors in measurement.

A single station point should be used as the basis for measuring as many points as possible and as necessary. The same principle applies to floor plans, sections, and views.

The tachymeter is generally unable to measure particularly small or finely de-

tailed elements precisely. This problem is most apparent in the depiction of windows and doors. Here, the tachymeter can be used to provide a rough location of the element, while details can be added later through a manual survey drawing.

### 2.3.4 Post-Processing

The resulting data still do not yield a finished plan. The time calculated for the project should also account for the fact that post-processing requires at least as much time as the measurements on site.

#### Flattening

The measured points are initially still associated with x-, y-, and z-coordinates. Since 2D-plan drawings are generally required and since any subsequent processing of the resulting file data will be two-dimensional, all points need to be further projected onto the respective view plane. This is accomplished by the process of so-called *flattening*, a function integrated into the software. In doing so, only the measuring points are flattened, not the control points. This means that it is possible to measure additional points within the same system even after the drawing has been flattened, since the tachymeter can still be positioned by using the control points.

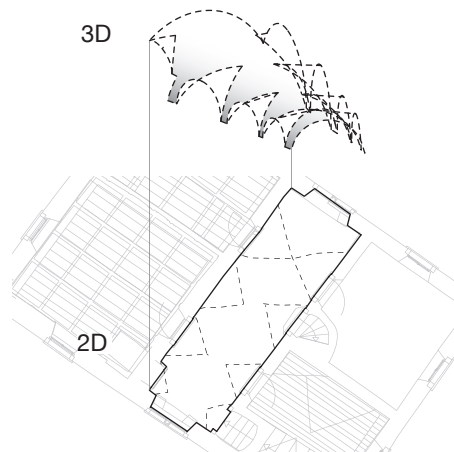

*The drawing is flattened, that is, the data measured in 3D is projected onto a plane so that the now two-dimensional drawing can be further processed.*

#### Completion and Addition

Once the file has been flattened, processing can begin.

Since the laser beam can yield imprecise results when measuring corners or edges, information on these features often has to be supplemented manually. As already mentioned, information should also be added about windows, doors, and other elements either consisting of small parts or finely detailed.

It is also possible to complete the measured survey drawing with photogrammetric data. The relevant information can simply be taken directly from the photograph. However, this presupposes that the plane is flat and that the required points have already been measured (► Chap. E, plan view, ► Chap. G.1).

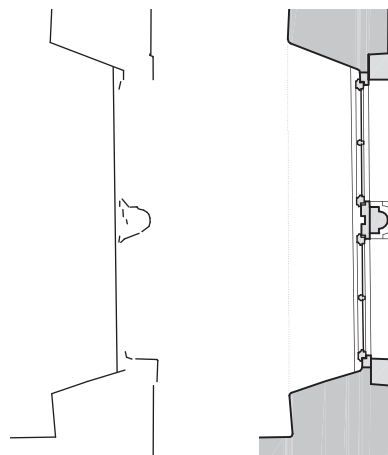

*Finely detailed areas should be added later manually, such as the profiles of windows and doors (left: raw survey drawing, right: drawing with detail added).*



*Raw plan drawing of the second floor, "Unterer Yngramhof".*

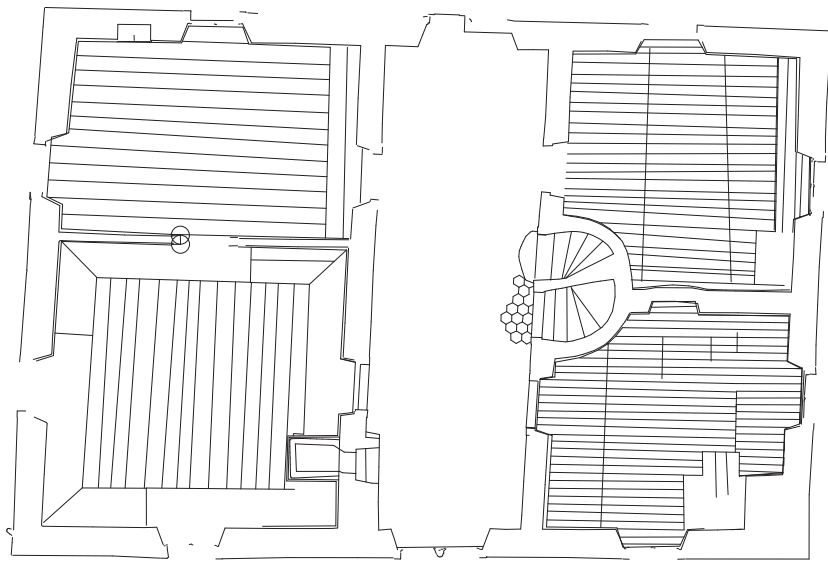

*Completed, processed, and publishable plan of the second floor, "Unterer Yngramhof".*

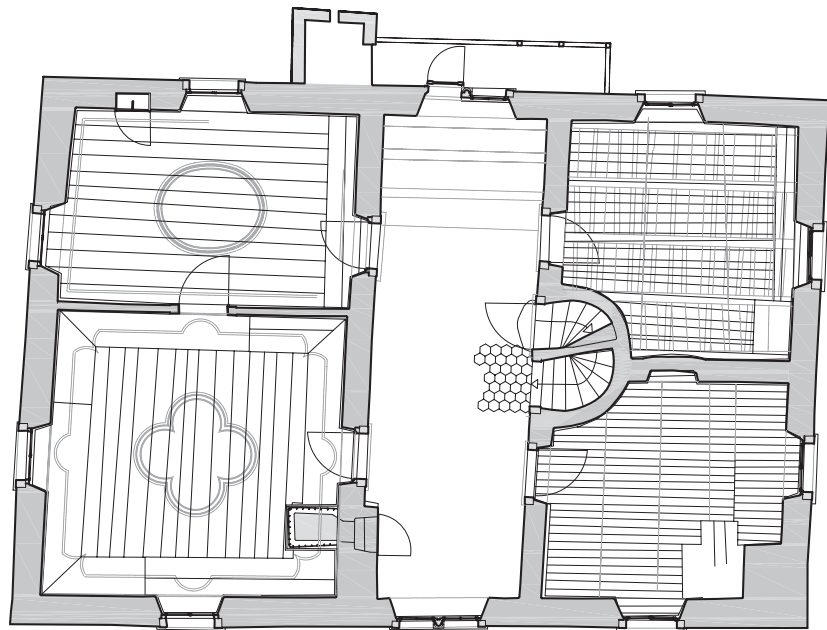

**Practical Tips:**

- Before beginning work, check the condition of the batteries.
- Pay attention to the condition of the floors before positioning the instruments. Avoid both smooth and vibrating floors.
- If necessary, establish and measure new control points before repositioning any instruments.
- Protruding corners, movable objects (such as lamps, ...) and ground cover can interrupt the light beam and lead to distorted readings.
- Allow for enough time for post-processing when planning the work.

**Possible Errors:**

- The laptop does not recognize the tachymeter: choose another USB-connection.

### 3. 3D-Scans

Since the 1980s, surveying has developed methods for recording objects of every form in three dimensions, including machines, automotive bodies, architecture, and sculpture. By now, 3D-scans have come to be a standard component of building surveys and will continue to be implemented in the future. The classical laser scanner, which uses an output device rotating in all directions to quickly compile extensive point clouds to indicate distance and horizontal and vertical angles in relation to an object, is ideally suited for the measured survey of larger buildings and complex spatial geometries. In addition, this device is usually also equipped with a camera system which can record a spherical image of the scanned surroundings and enrich the point cloud with information on colors. Smaller properties characterized by elaborate geometries or particularly smooth surfaces can be surveyed by using structured light scanners, accurate to within a fraction of a millimeter. Handheld 3D-scanners can serve as an alternative, which do not need to be mounted onto a tripod and thus allow for greater flexibility and even for the documentation of a room while moving. The advantages of a handheld scanner are, however, balanced by a loss of accuracy in measurement.

The various methods can also be combined cumulatively after subsequent processing of the measurement data. All of the scanners used during the building survey require a reference system in order to locate the measurement points. For this purpose, a sufficient overlap of the areas measured from the location of individual setups is often adequate. Targets can be used if a greater degree of accuracy is required. In all cases, the use of specialized, highly precise measurement technology can help to save considerable time and labor on site. The instruments also allow a property to be measured without direct contact and to a high degree of precision. The scanners are equipped with an on-board control interface or can be linked to mobile devices which allow for measurements to be taken remotely. The work flow on site can thus

be highly efficient, since shadowing on the resultant scans can directly reveal any defects in complex geometries such as roofing constructions. However, the time and effort needed for post-processing and the creation of survey plans on the basis of the scanned data require a considerable number of work hours as well as considerable processing power in order to process the large amount of data.

Following the scan, the resulting point clouds need to be further processed using special software for registration before they can be imported into widely used CAD-software in order to create 3D-models or two-dimensional plans.

Scans are ideally suited for the quick and highly accurate recording of interior and exterior spaces. In particular, they provide the best method of documentation for complex geometries such as vaulted or arched surfaces. In comparison with traditional, manual survey recording or with tachymetric recording, which both integrate the registration of architecturally historical findings into the process of the building survey, scanned data at first provide an image of the property independent of any evaluation of the findings. The data thus need to be supplemented and interpreted later. Reading the output of the scanned data requires a great degree of experience by the person responsible. A supplementary examination on site is essential in order to merge the results of the measurements with the documentation of findings.

#### 3.1 Laser-Scanners

##### Fields of application

Laser scanners are suitable for recording almost all types of spatial geometry. As long as the surfaces are particularly complex, as is the case with curves, decorative elements, damaged properties, etc., the scanners represent the first choice for creating highly accurate survey recordings.

The range of a laser scanner depends on the type of instrument used, from ca. 30 m up to over 100 m. The point density

achieved by the scan diminishes proportionally to the distance of the instrument to the target.

#### Reference System

Many laser scanners can be repositioned at a different station point by calibrating points common to several setups for the new location. The establishment of an independent reference system is in many cases accordingly unnecessary, as long as enough points overlap across the individual setups. It is, however, also possible to integrate the 3D-laser scanner into a reference system similar to the measuring grid used in tachymetric surveys. For this purpose, reference points marked with a checkerboard pattern are mounted onto a building or property and are either measured in or automatically registered by the scanner.

#### Operating Procedures

Laser scanners emit a continuous laser beam which moves across an object in a grid pattern. Sensors in the device catch the reflection of the light and determine the distance to the object by calculating the time needed for the light beam to return. The position of the measured point in space is determined by triangulation. Tightly knit grid patterns are possible. Depending on the speed of measurement, a scanner can record a large number of measurement points each second. The resulting grid can lead to a dense amount of information, a so-called discrete metric space formed by the measurement points. The reflected and mathematically processed signal of the laser beam thus produces a densely knit point cloud of three-dimensional measurement points, which are each defined in relation to three coordinate values. The process of mapping laser scanning, that is, the determination of signal intensity through reflection phase shifts, can enable information concerning the surface texture of an object to be read and to be conveyed in grayscale images. Attention should be paid to shaded areas which arise through the particular spatial geometry of an ob-

ject and to partially shaded areas created by disruptions of the laser beam, such as by trees or textiles situated in front of the target object. These areas should be minimized by taking repeated measurements.

#### Analyzable Results

Point cloud consisting of three-dimensional measurement points.

#### Post-processing and Creation of Plans

In order to create plan drawings from the measurement values of the point cloud, a closed surface can be generated for the three-dimensional, virtual object by using a triangular mesh plot. This plot can, for example, yield information on the geometries of curved surfaces and any associated deformations. Alternatively, vertical and horizontal working planes can be introduced as lines of intersection, which can be used to create floor plans or section drawing. For this purpose, the individual points of the measurement data need to be redrawn as a line drawing.

### **3.2 Structured Light Scanners**

#### Application

Used as a supplement to tachymetric building recordings or to laser scans for particularly complex areas of architecture, including sculptures or particular decorative elements with valuable, delicate surfaces. Very dark or highly reflective surfaces can be problematic. The range of structured light scanners is confined to the direct vicinity, the resolution can be extremely high.

#### Frame of Reference

The integration of the scanner data within a larger spatial context requires either a superordinate measuring grid or a sufficient number of reference points in all geometric dimensions. Independent, additive sections of a scan require that at least the measurement location and the orientation of the scanning instrument be measured as points of reference.

### Operating Procedures

Highly simplified, the operating principles of a structured light scanner can be roughly described as follows: The scanning instrument consists of a projector and two cameras firmly mounted onto a tripod. The distance and geometrically spatial relationship between the object and the instrument are determined by triangulation. The precise projection of many parallel lines of light in pre-determined contrasts of light and dark, the so-called Coded Light Approach, enables individual lines to be determined on the surface of the object by means of a special tabular calculation. These lines of light form the basis for the so-called light-section process, which involves the projector emitting a straight line. Since the two cameras, however, capture the line at an angle, they are able to register even small deviations based on the principle of stereoscopic viewing. By using the process of phase shifts, that is, the evaluation of shifts in light phases

and modulations in brightness of the reflections with respect to the emitted light beam, the results can be used to calculate the geometry of the object.

### Analyzable Results

Three-dimensional point clouds in ASCII-format, which can be converted into CAD-compatible data, and a measured image of the surface structure with extreme precision.

### Post-processing and Creation of Plans

The evaluation of the resulting measurements requires the use of specialized computer programs, which calculate the point clouds or coalesce the measurement data into a three-dimensional surface. Here as well, the plan drawing is subsequently created manually through post-processing of the measurement data. The measured image can be used to generate wire frame models or line drawings.

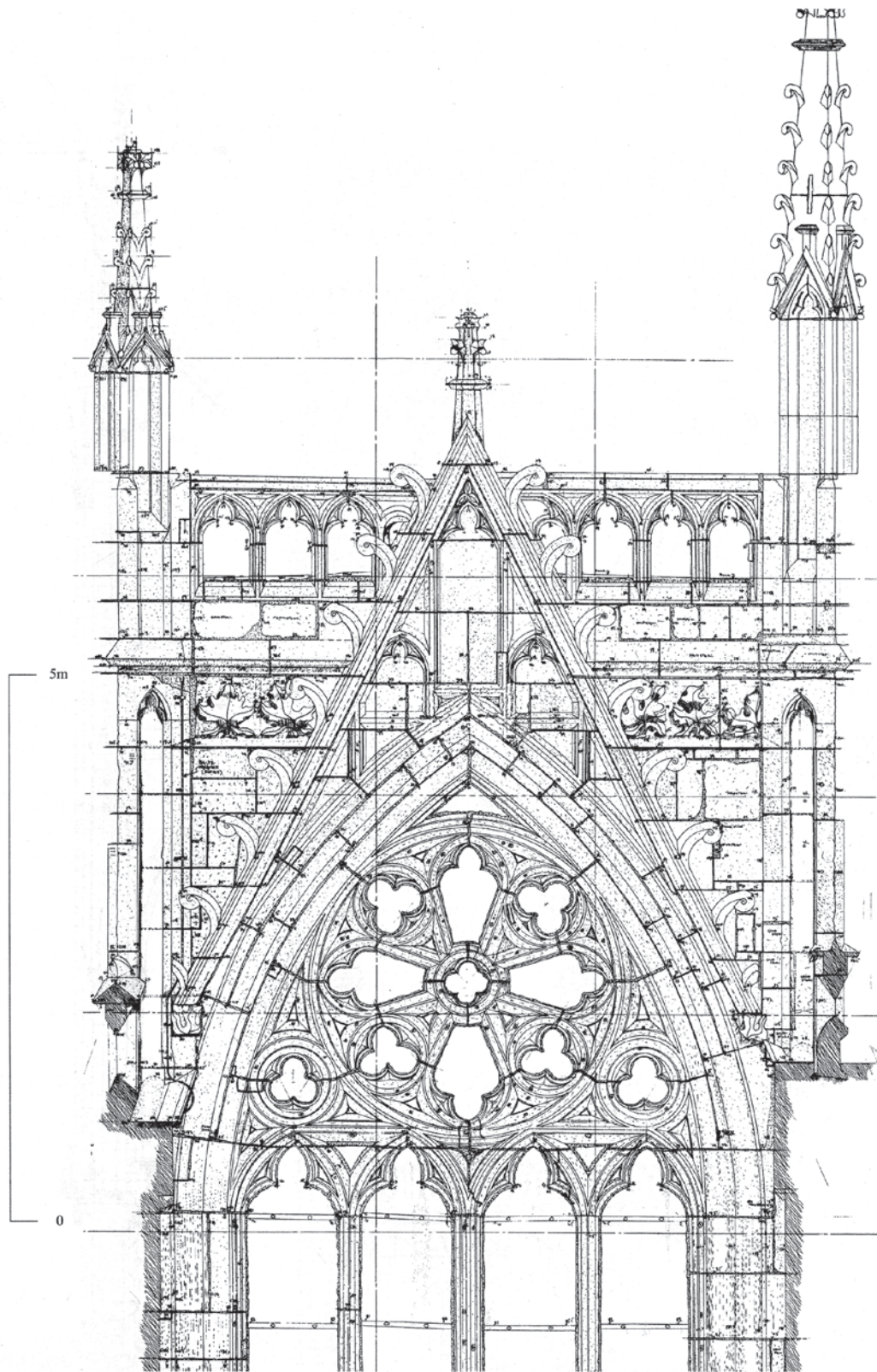

**Regensburg Cathedral**

View of the tracery window in the choir, manual survey drawing measured from scaffolding  
Survey and drawing Ph. Caston, 1986–2001

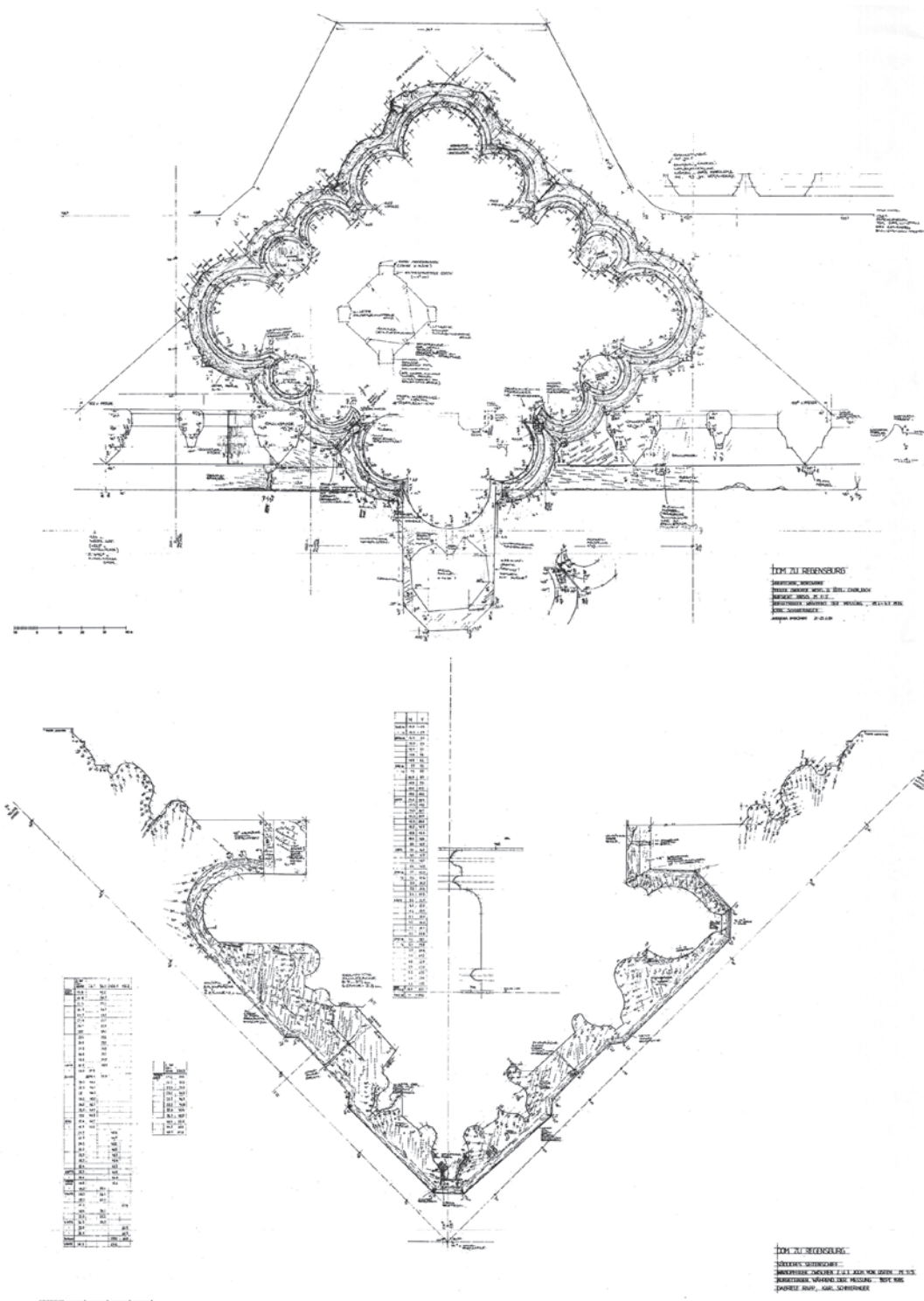

### Regensburg Cathedral

Sections of the north wall of the main choir and of the pilasters in the side-aisles, manual survey drawing  
 Survey and drawing K. Schnieringer, 1985/86/94

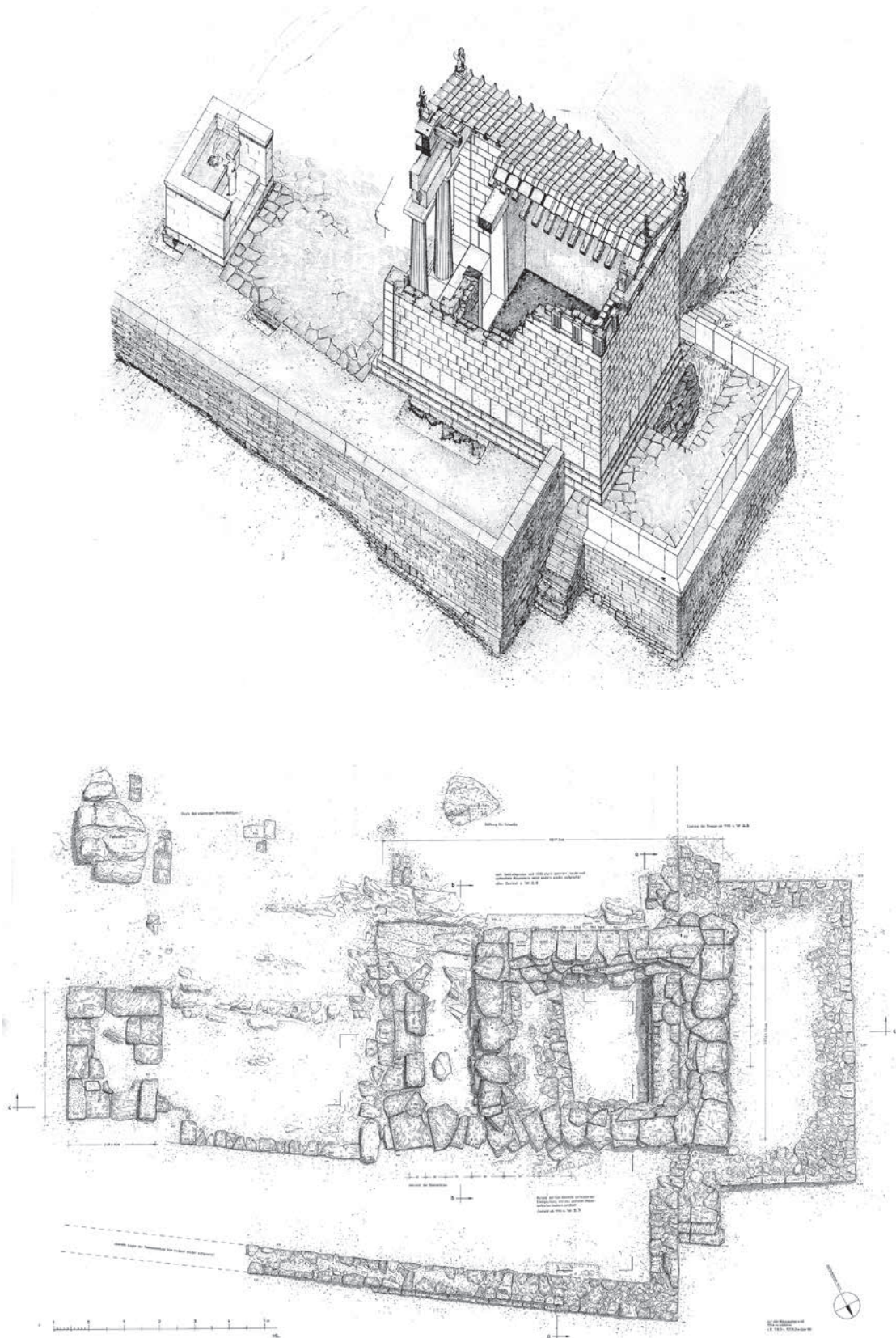

**The Temple of Artemis in the Delion Sanctuary on Paros**

Bottom: plan drawing of stones; Top: Reconstruction

Survey and drawing M. Schuller, 1980

(Dissertation)

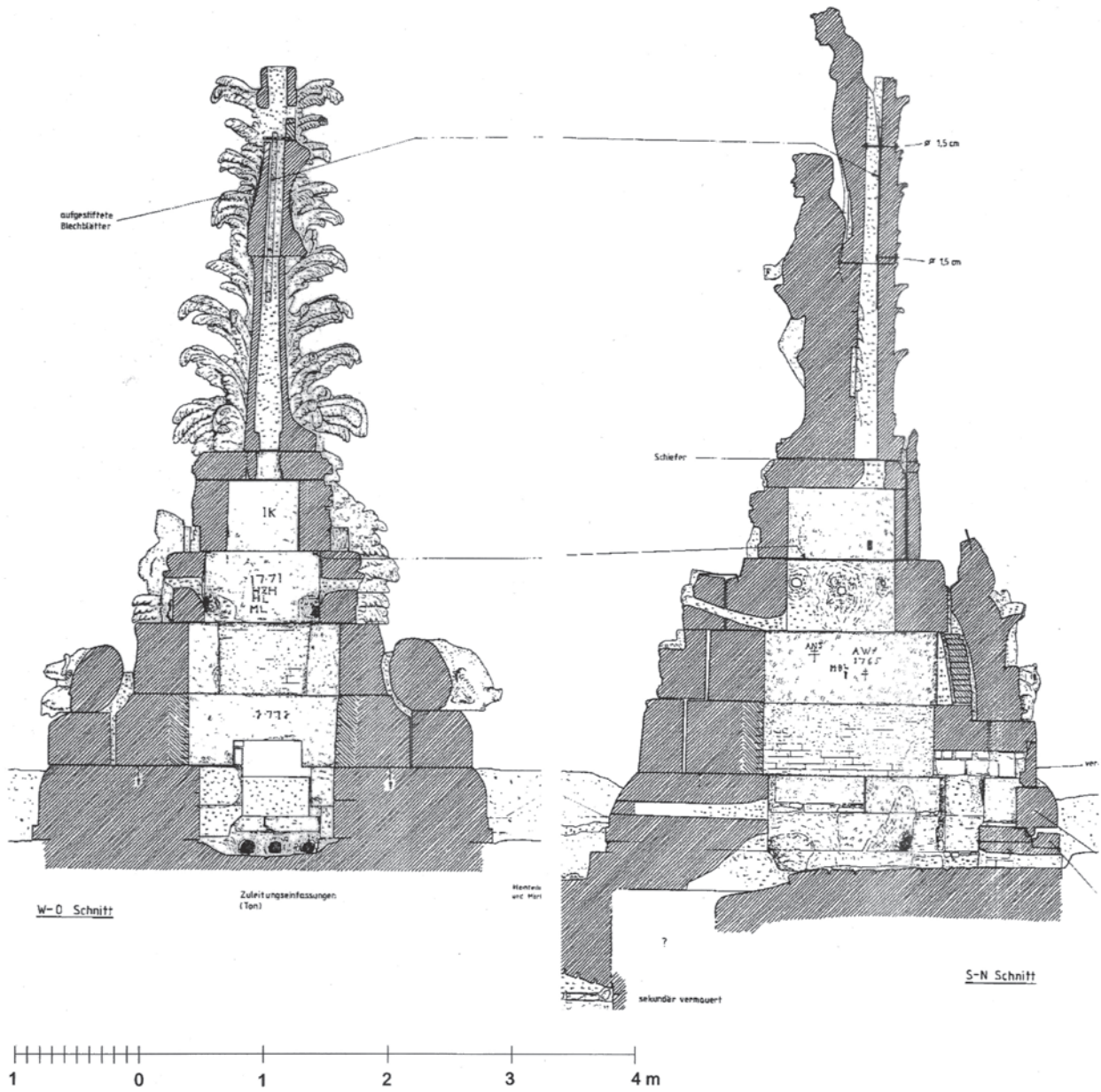

**Cascade waterfall of Schloss Seehof**

Section through the "Hercules"-group, manual survey drawing

Survey and drawing M. Schuller, 1986



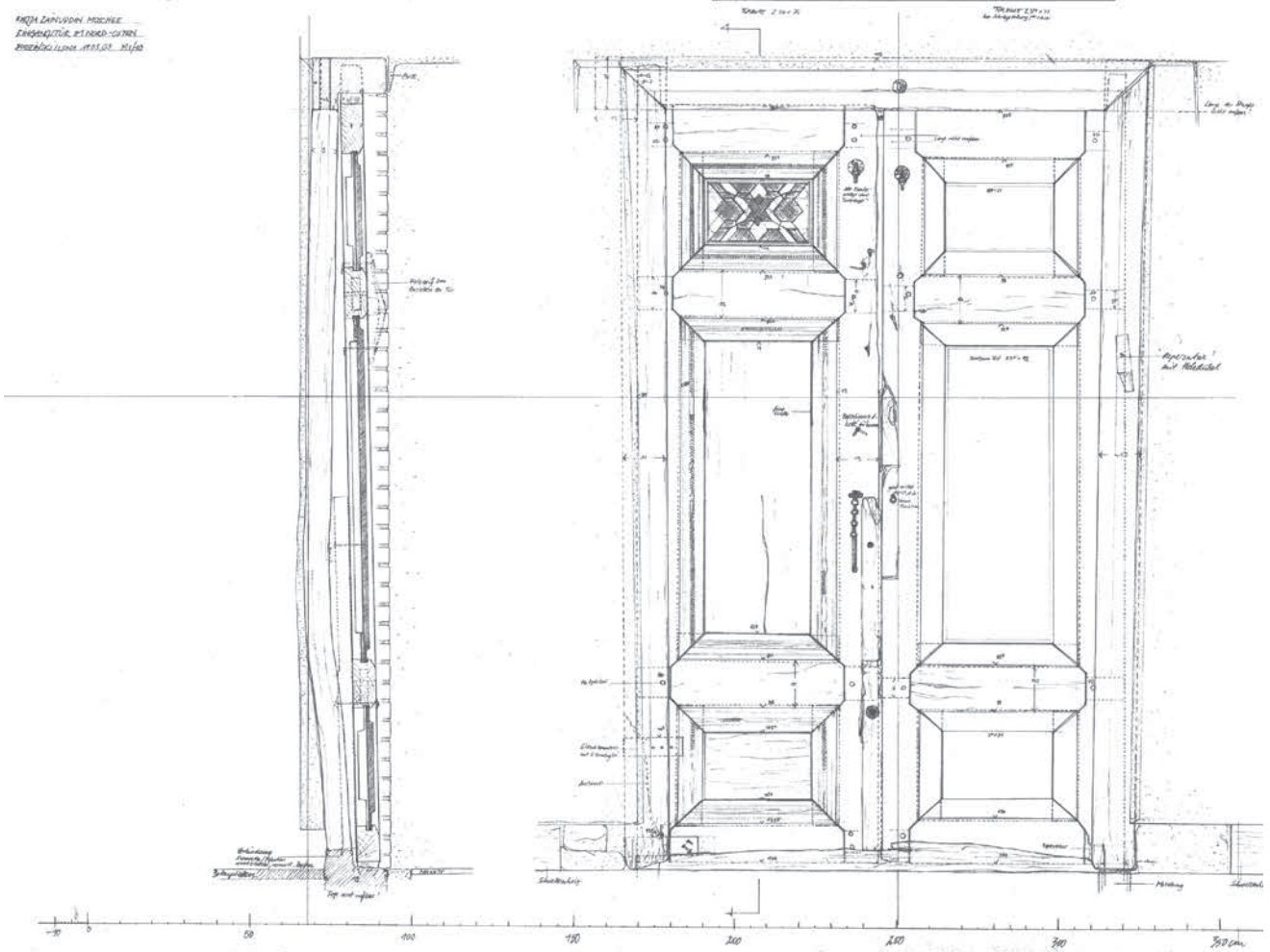

**Khoja Zainuddin Mosque, Bukhara/Uzbekistan**

Section/view of northeastern entrance door, manual survey drawing

Survey and drawing I. Dudzinski, 2009

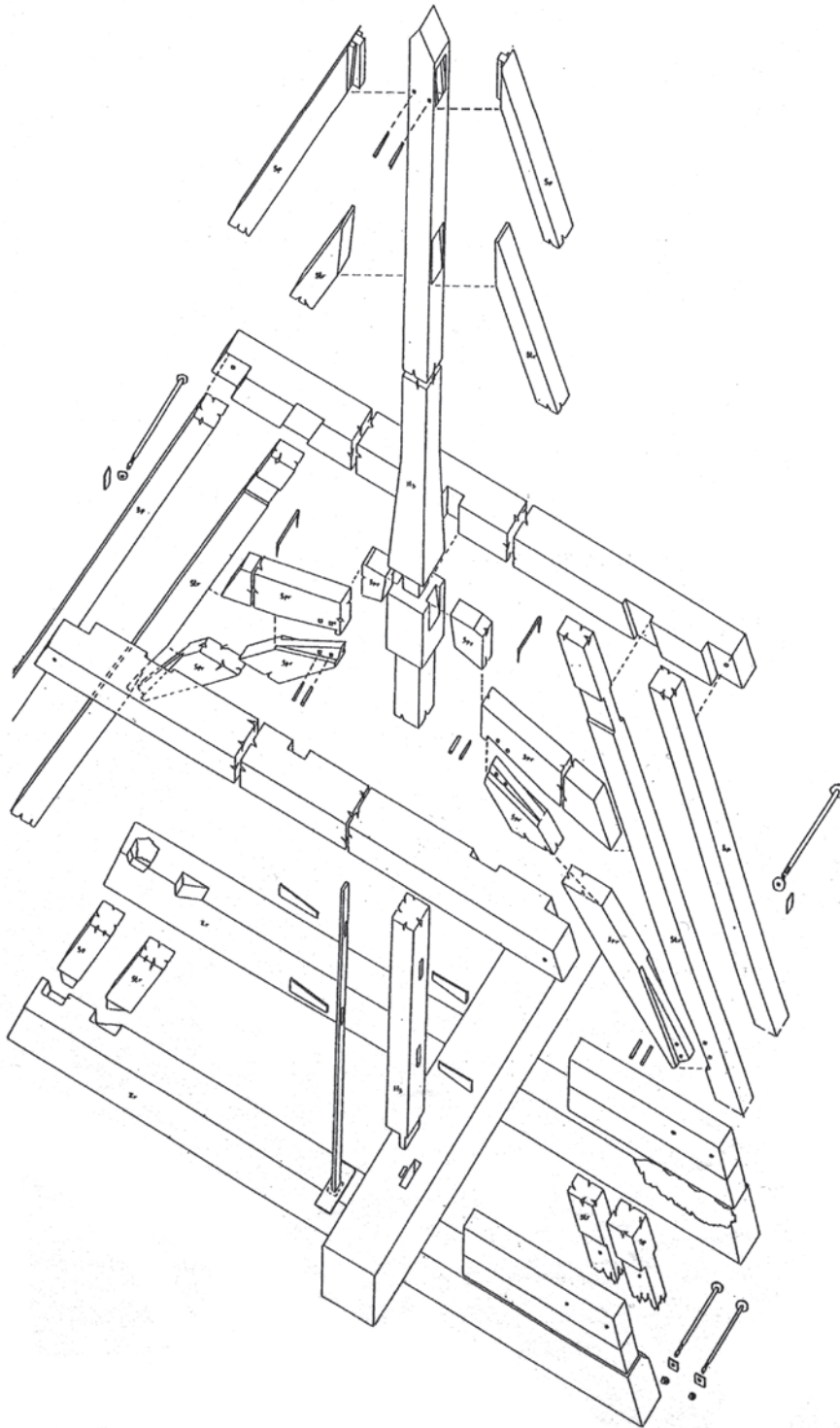

**St. Elisabeth, Bamberg**

Exploded isometric drawing of the baroque roof

Drawing by R. Mauersberger, 1991

(Final thesis paper for the postgraduate program in Heritage Conservation, Universität Bamberg)

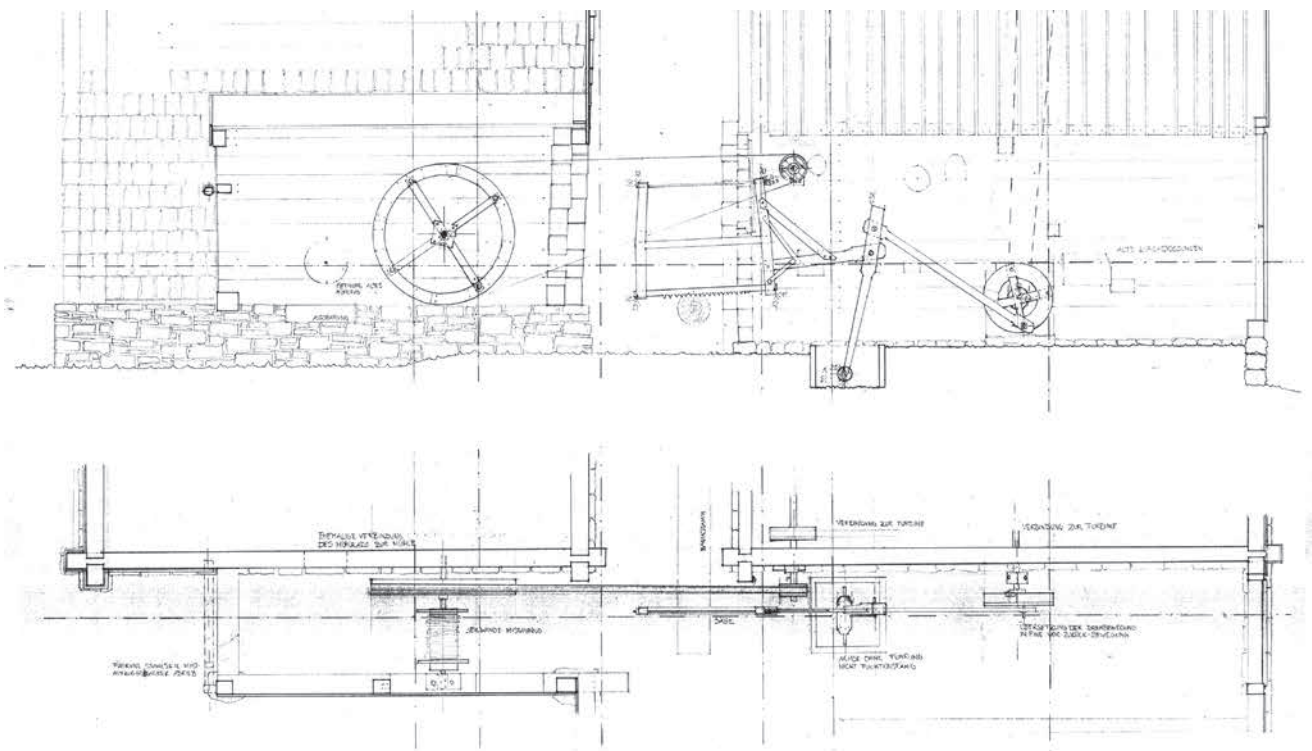
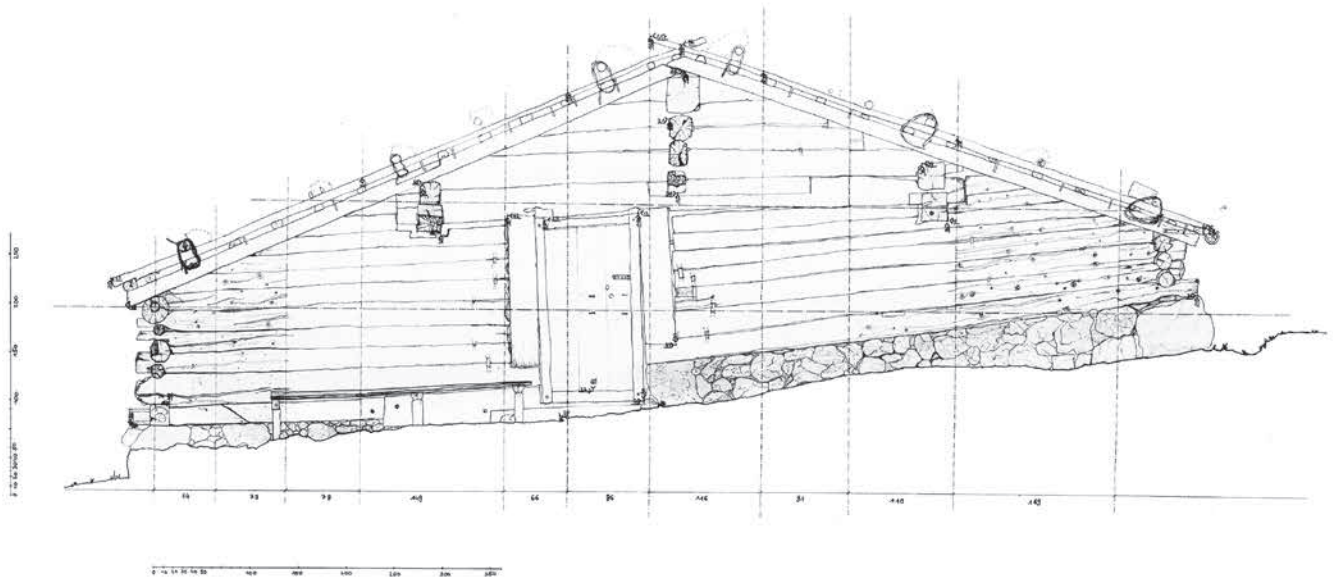

**Open-air museum Glentleiten**

Top: "Hainzenkaser", view, survey, and drawing Abu Shakra/Böck/Eckert/Gläser/Ludwig/Schidlo, 2014

Bottom: "Talgutlehen" lumber saw, survey and drawing Krubasik/Hartmann/Trojer/Frömming/Stolz/Traxler, 2014 (within the course on Building Survey and Building Archaeology, BA in Architecture, TUM)

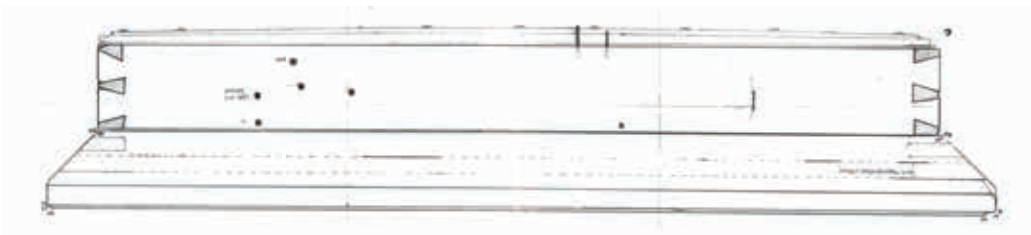
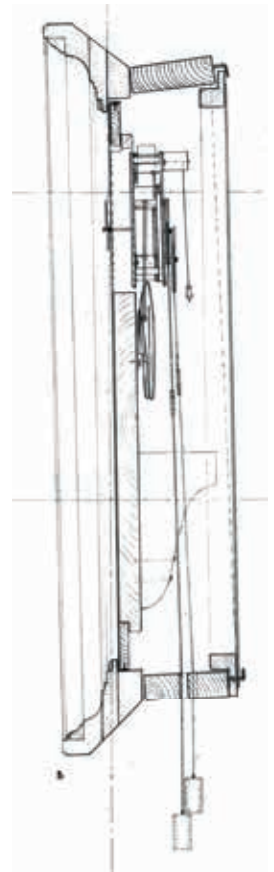
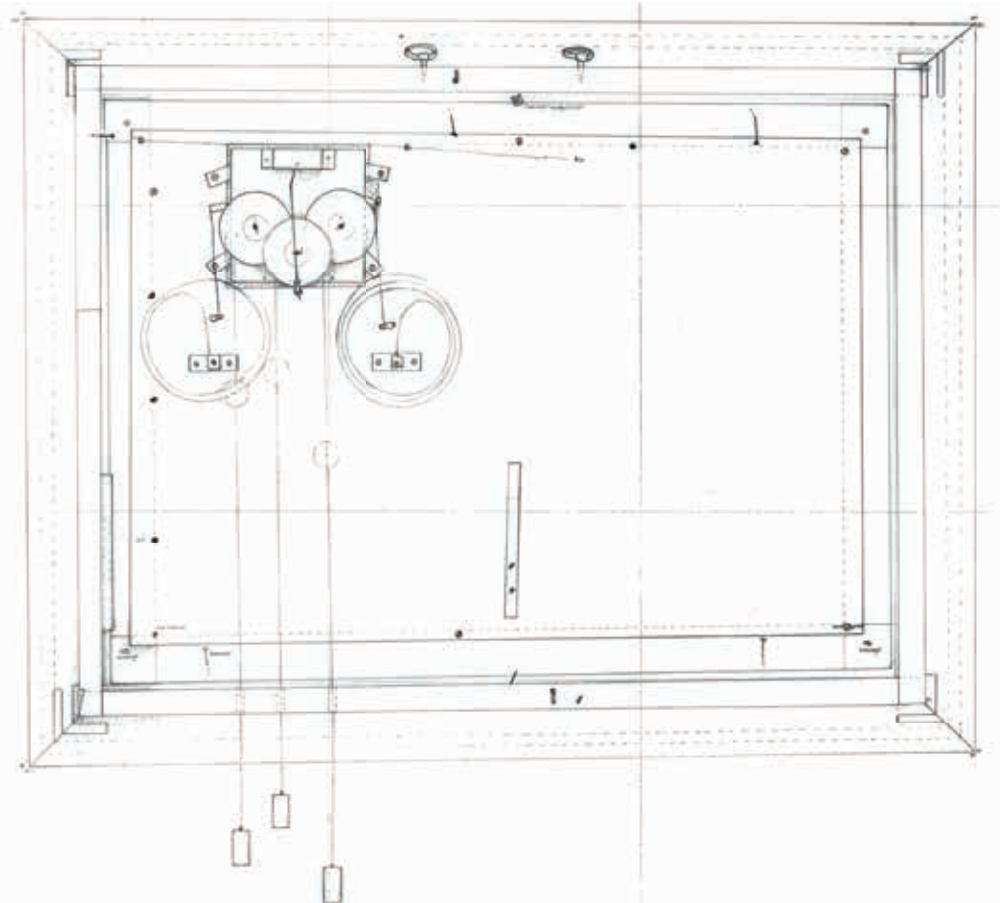

**Illustration of a clock – picture clock**

Survey and drawing A. Krez, 2015

(within the course “Project Documentation”, degree program MA Restoration Sciences, TUM)

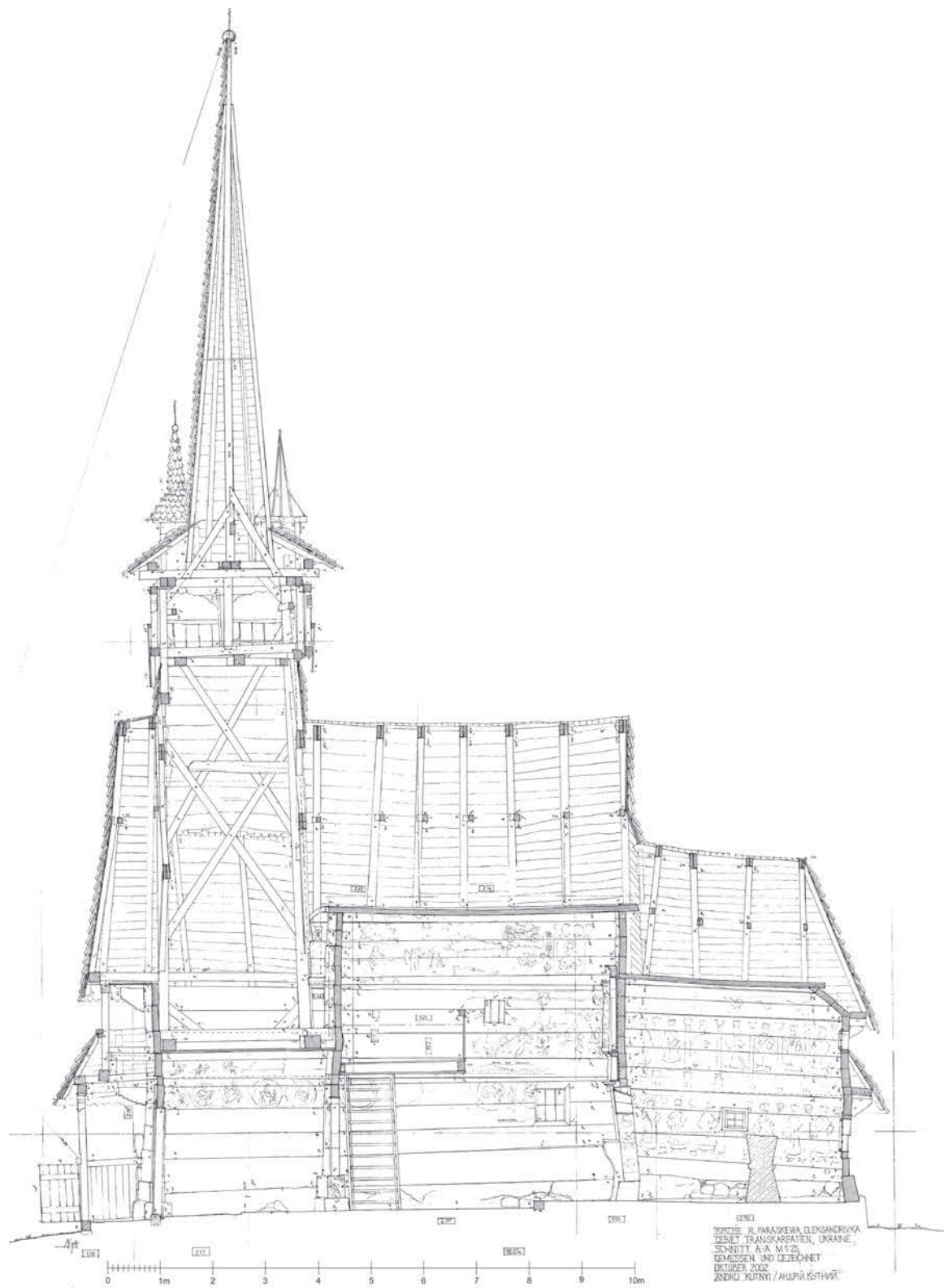

**Wooden Church of St. Paraskewa, Oleksandrivka (Transcarpatia, Ukraine)**

Vertical section, manual survey drawing

Survey and drawing A. Kutnyi, 2002

(Dissertation)

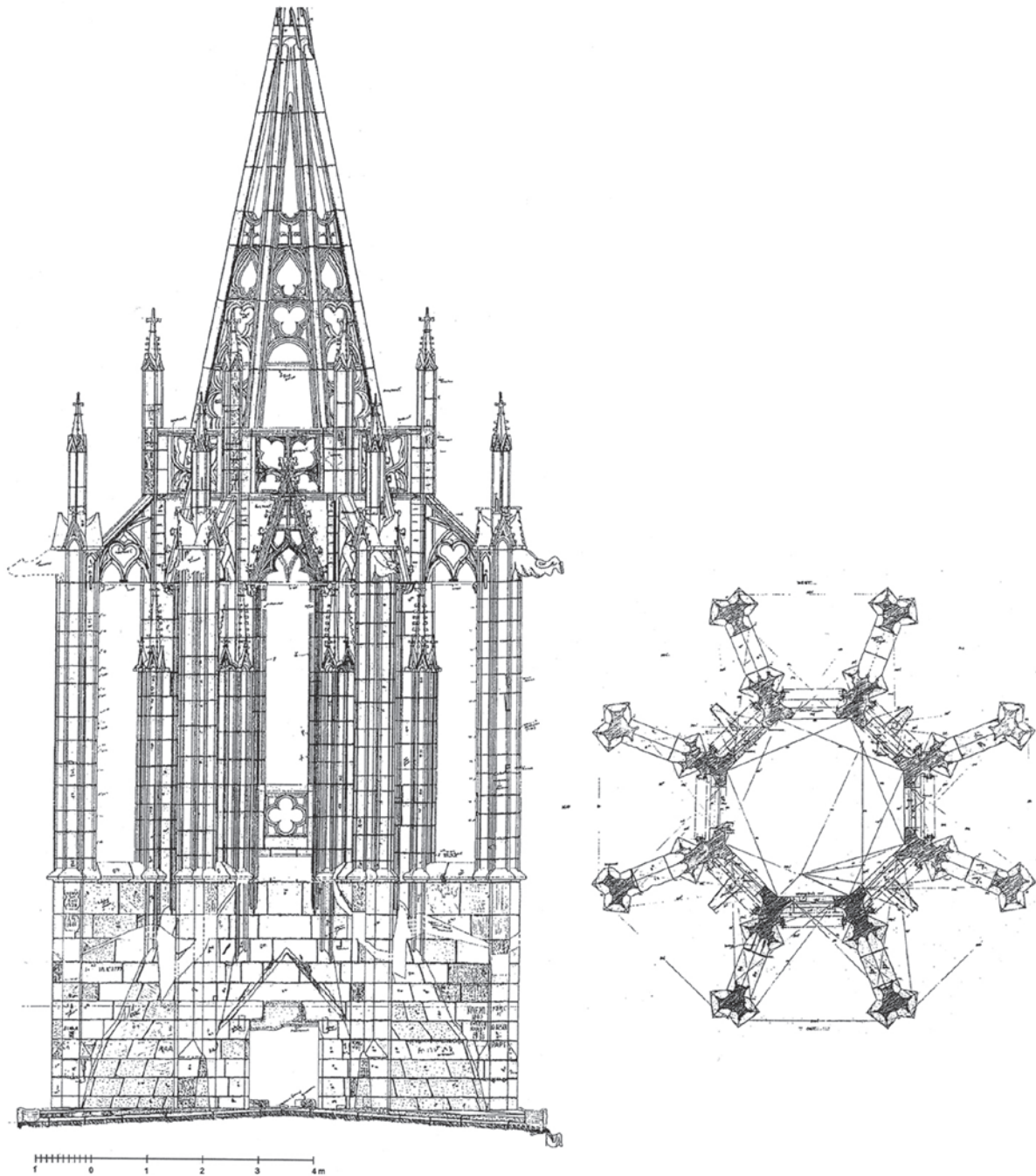

**Cistercian Church at Bebenhausen**

View and floor plan of the tower above the central crossing (“Vierungsturm”), manual survey drawing

Drawing Ph. Caston, 1994

(Dissertation)

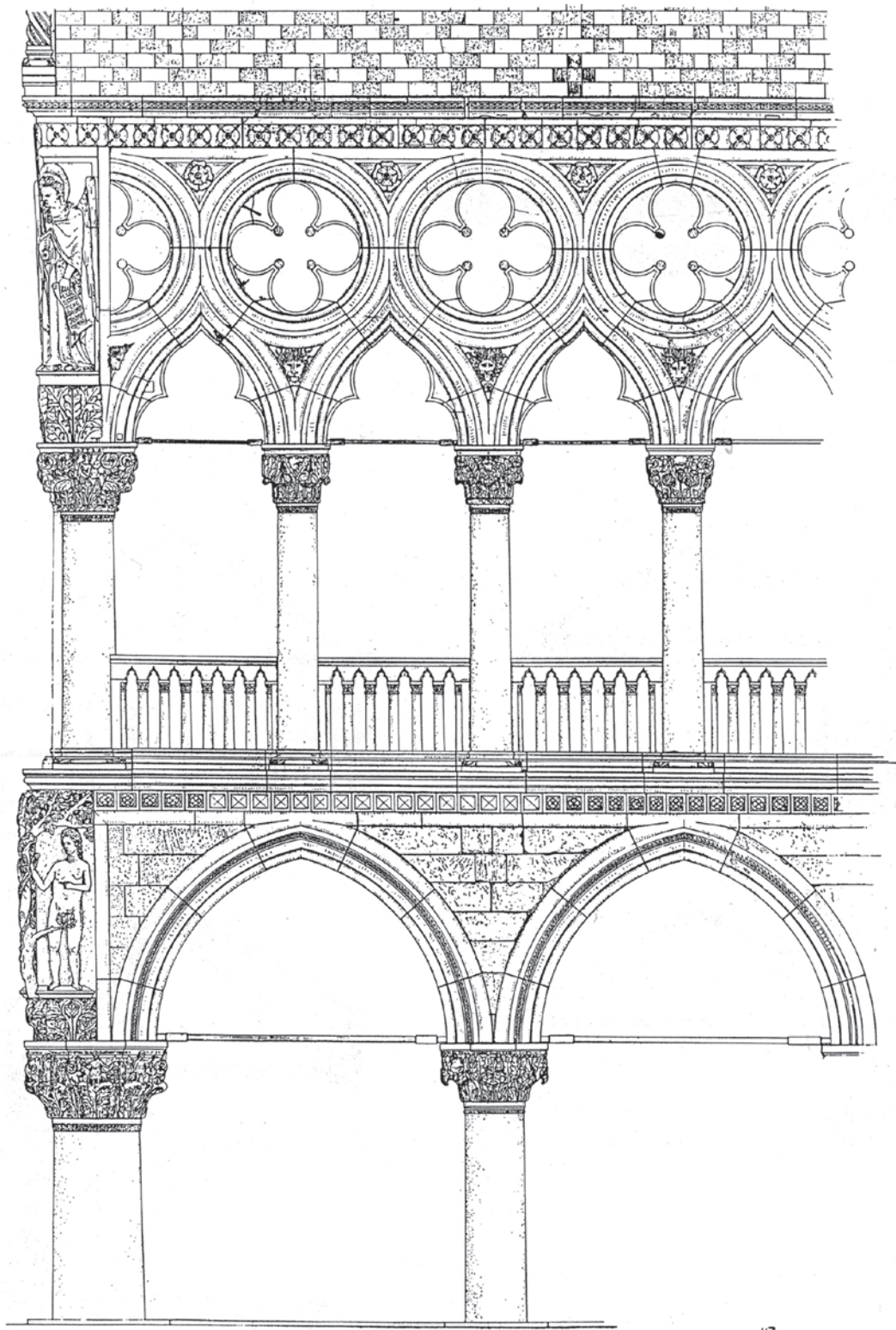

**Palazzo Ducale, Venice**

View of the southern corner, manual survey drawing from scaffolding

Pencil on cardboard, scanned for publication, with measurements and labels deleted. No redrawing necessary!

Survey and drawing M. Schuller, 1985

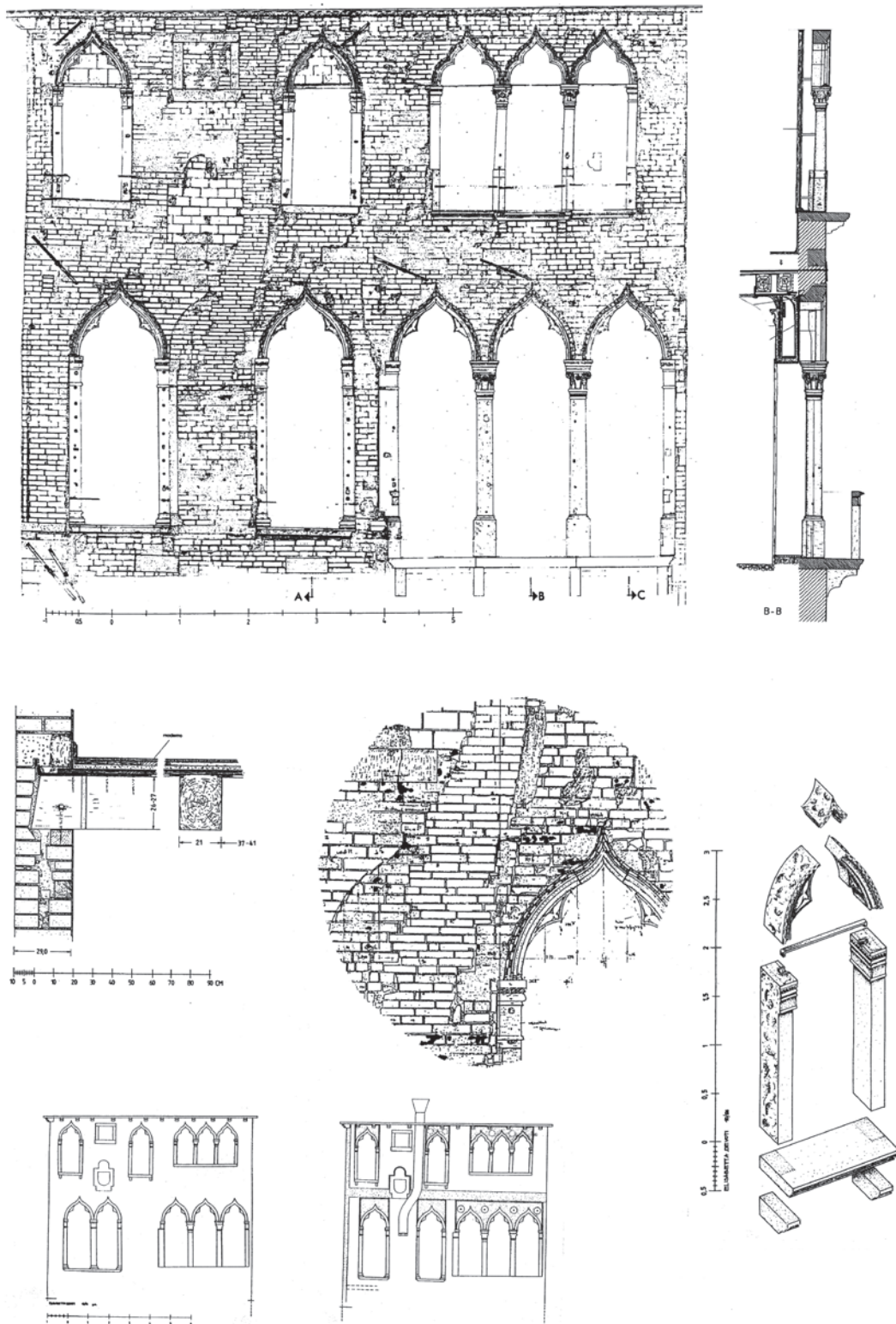

**Corte Remer, Venice**

Facade, section, and details, manual survey drawing from scaffolding  
 Survey and drawing M. Schuller, 1985



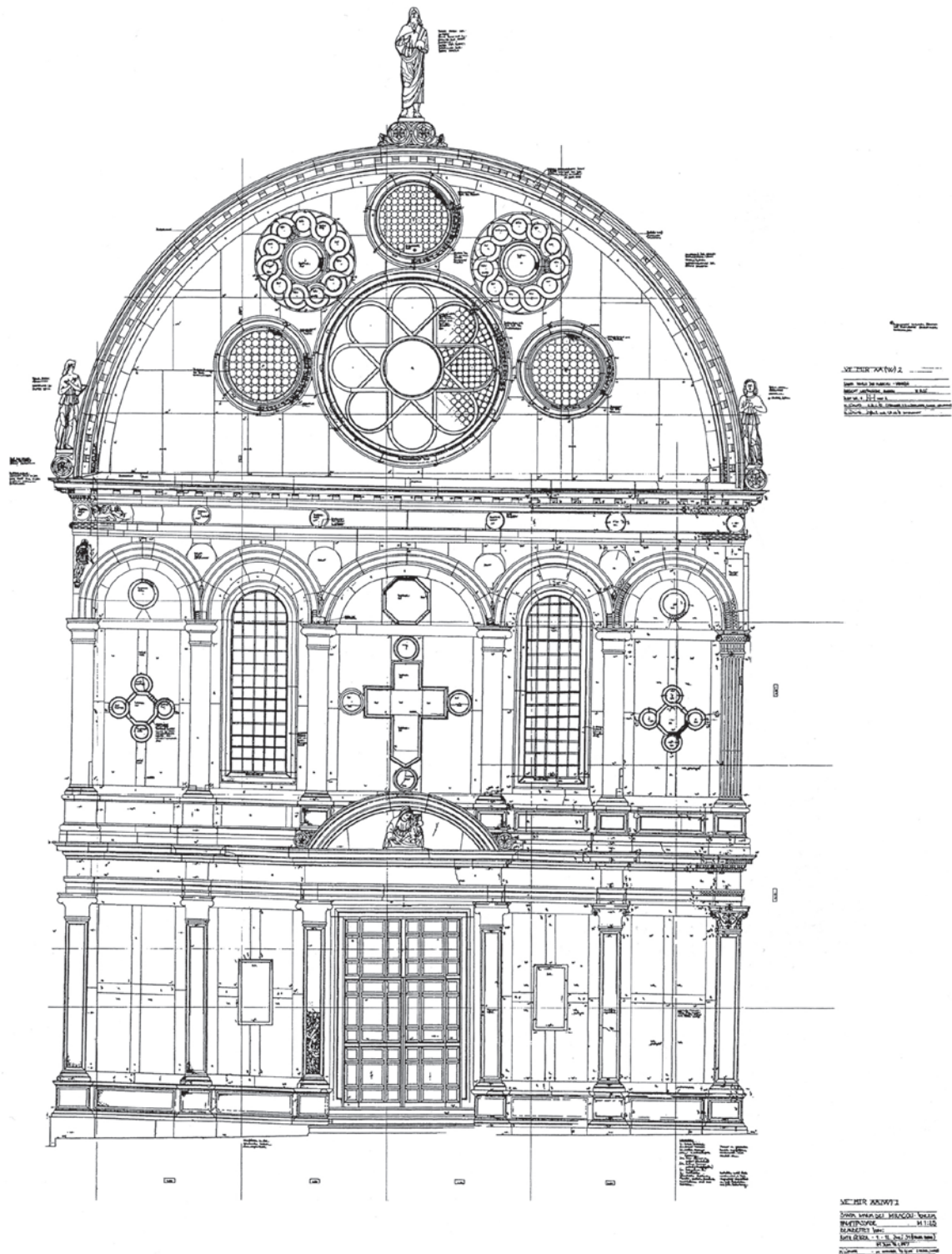

**St. Maria dei Miracoli, Venice**

View of the main facade, manual survey drawing from scaffolding

Drawing R. Geiger, M. Lüpnitz, 1991–93

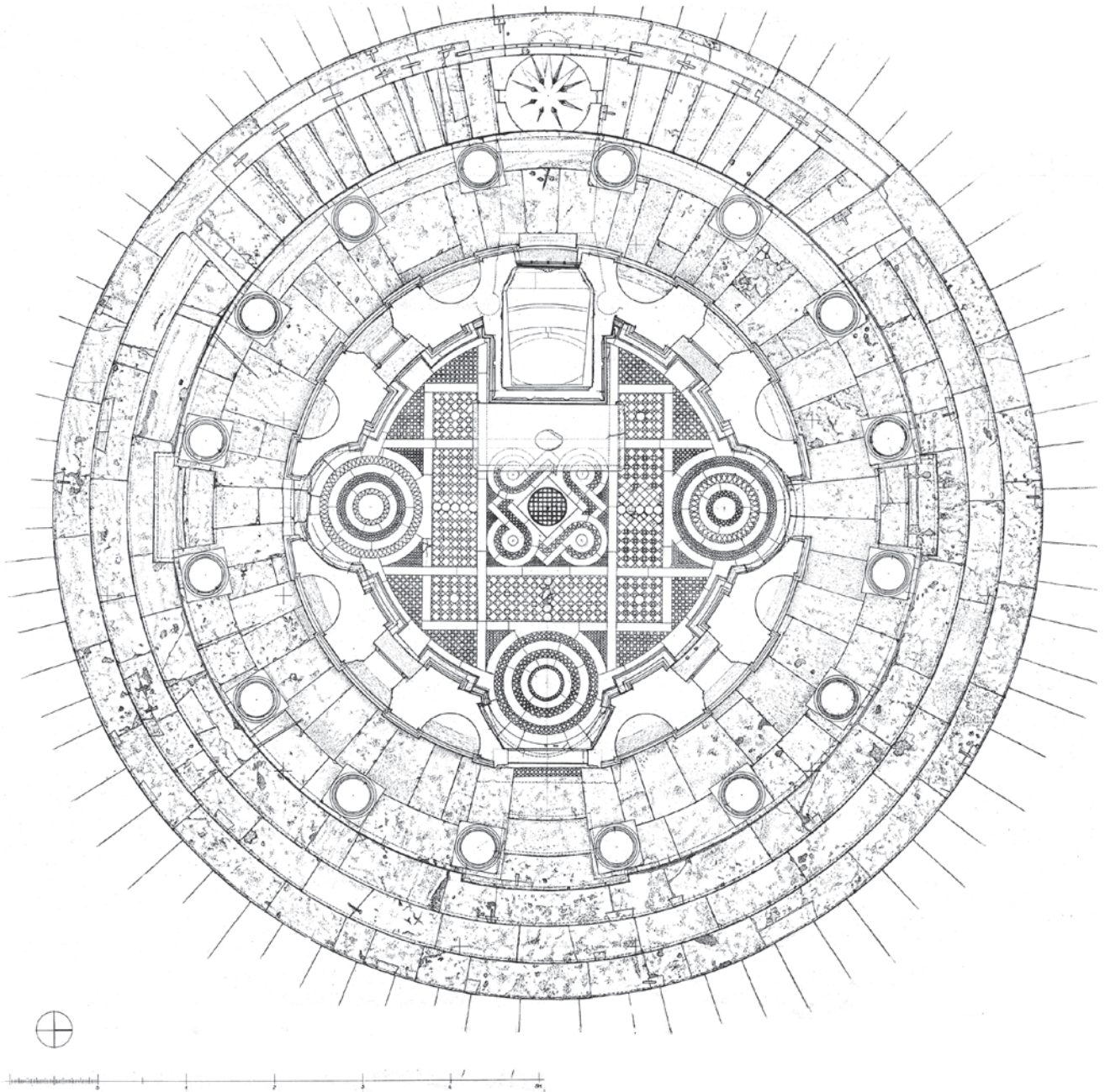

**The Tempietto of Bramante near St. Pietro in Montorio, Rome**  
Floor plan of the cella, manual survey drawing aided by tachymeter  
Drawing K. Papajanni, 1995

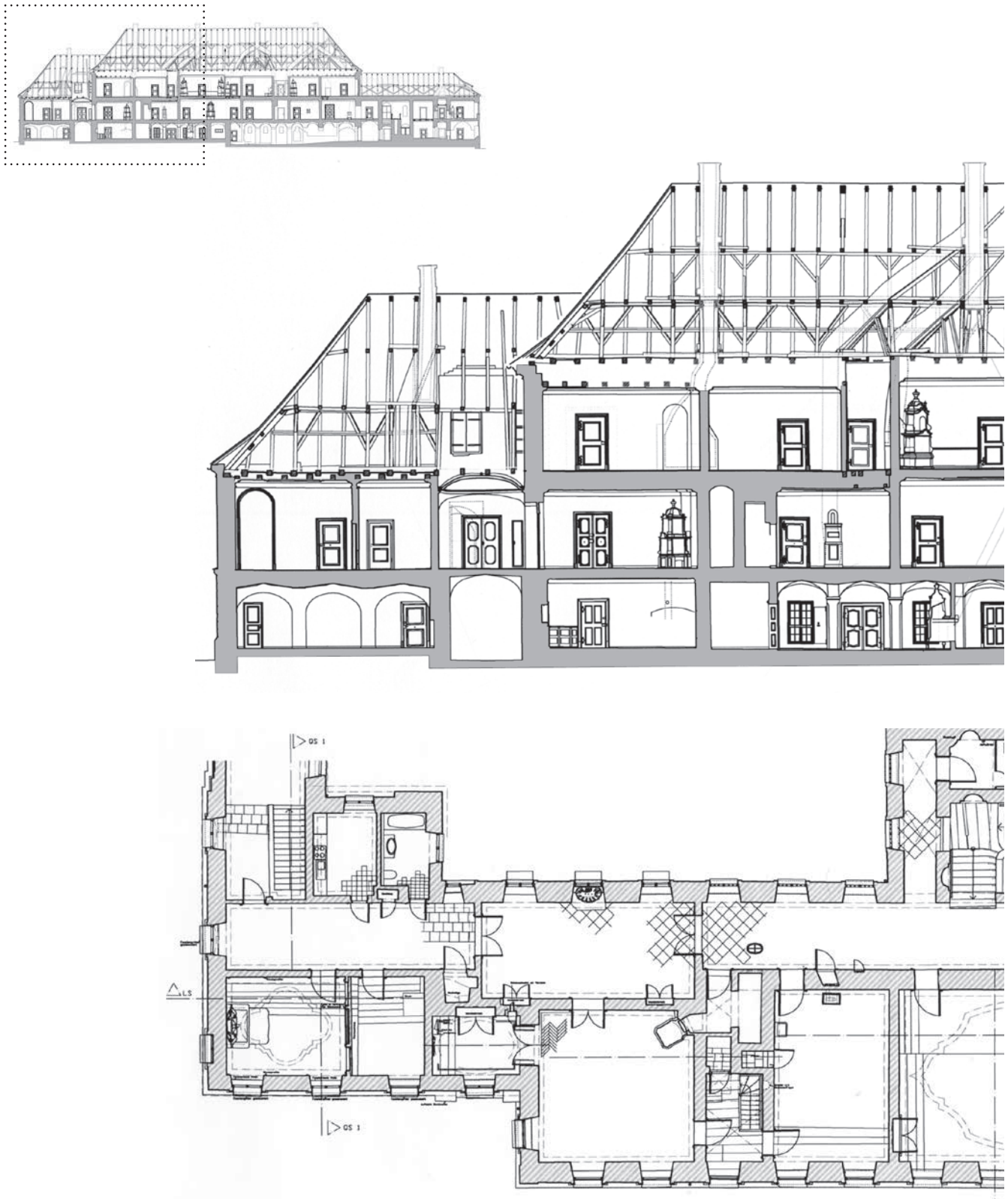

**Abbey of Raitenhaslach, Prelate's Floor**

Longitudinal section and floor plan, tachymetric survey drawing with digital post-processing on site

Drawing Kohnert – Büro für Bauforschung, 2008

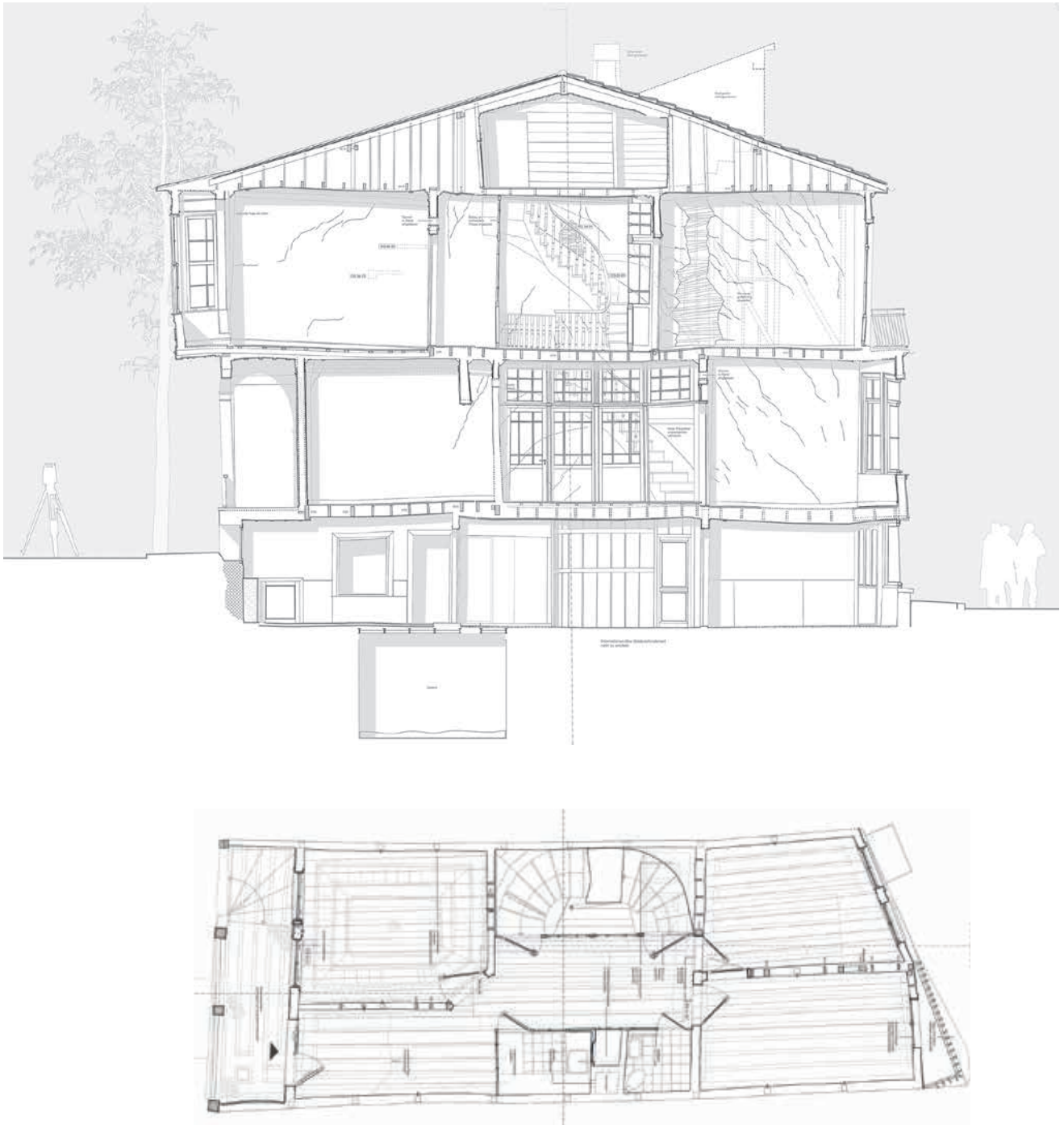

**Çınar Caddesi 35, Büyükağa (Prinzeninseln/Istanbul)**

Floor plan of the ground floor and longitudinal section with map of cracks in the building

Manual survey drawing aided by tachymeter and subsequent tracing with CAD

Survey and drawing by T. Busen, B. Todt 2009–10

(Thesis for special diploma in the degree program on Architecture, TUM)



---

**Naumburg Cathedral**

Statue of the founder Syzzo, left: 3D-light-scan, center: orthogonal view, right: digital tracing

Drawing D. Jelschewski, 2012

(Dissertation)

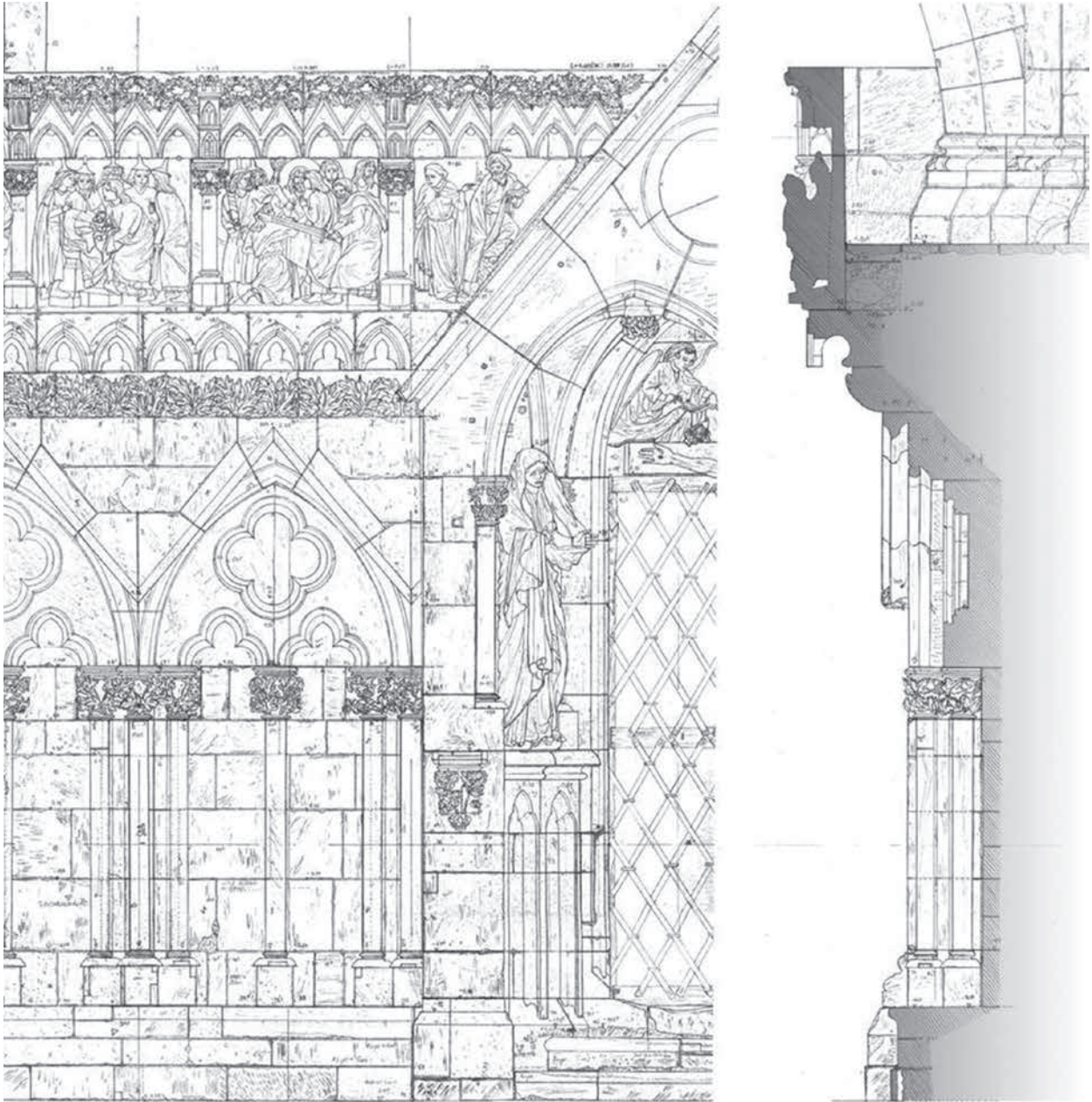

**Naumburg Cathedral**

View/section of choir screen, manual survey drawing

Drawing I. Dudzinski, 2012

(Dissertation)



*Tracing of a facade recorded with photogrammetry (rectified mosaic and detailed view).*

# Photogrammetry

---

## 1. Definition and Terminology

Photogrammetry deals with the acquisition of geometric information from objects, particularly of spatial, but also 3-dimensional nature, with the aid of image captures. While terrestrial survey/geodesy relies particularly on aerial photographs or photogrammetry, architecture and heritage conservation studies normally prefer images taken at closer distances from locations on the ground (terrestrial photogrammetry). As the market has continued to provide possible options at a reduced cost, survey recordings and analyses from the air have also become increasingly current in architecture and heritage conservation.

The simplest form used in the field of architecture is photogrammetric measurement from a single photograph. Strictly speaking, the term is misleading, since spatial information cannot be extracted from a single image as long as the image remains unconnected to additional data. The method rather depends on the rectification of an image taken from a particular perspective into a rectified mosaic composed true-to-scale

## 2. Correcting for Distortion

### Areas of Application / Goals

**As a basis for mapping:** A particularly suitable area of application for single-image photogrammetry is the creation of base plans in order to map damages. On the one hand, the greater clarity offered by the rectified mosaic has the advantage of affording easy orientation within the plan. On the other hand, larger surfaces can be quickly documented as part of a clear process by portioning them into smaller sections based on individual details (such as

facades of natural stone, clinker masonry, or damaged plaster surfaces).

The rectified image can later be “traced” with the help of CAD-software, that is, the edges and structural borders can be transferred to a line drawing. Alternatively, the rectified mosaic can be used directly for the mapping of damages. Otherwise, attention should be paid that the rectified image still allows for the clear entry of annotations onto the map.

### **Rectified Mosaic/Supplement to the Measured Survey:**

In addition to providing a basis for maps, photogrammetry can also yield valuable information for documenting the construction of an object. Since the images are accurate to scale, the rectified mosaic can supplement certain areas of the measured survey, or even replace it entirely. Photogrammetry quickly yields significant results especially when applied to facades without surfaces decorated in heavy relief. The rectified mosaic has particular advantages with respect to the measured survey when applied to wall surfaces or structures. If, for example, the surface structure of a wall constructed from quarry stones is to be measured tachymetrically, this would require a considerable expense of time. In contrast, the rectified mosaic lets the structure be immediately recognized, which information is normally sufficient. It will always remain possible to link the rectified mosaic with the tachymetrically measured survey plan, for example for areas which exhibit a rather rough or uneven structure. However, this sort of linking should always consider the overall plan presentation. The photographs should not figure too predominantly in the overall plan, since this carries the risk that other information on the plan be lost.



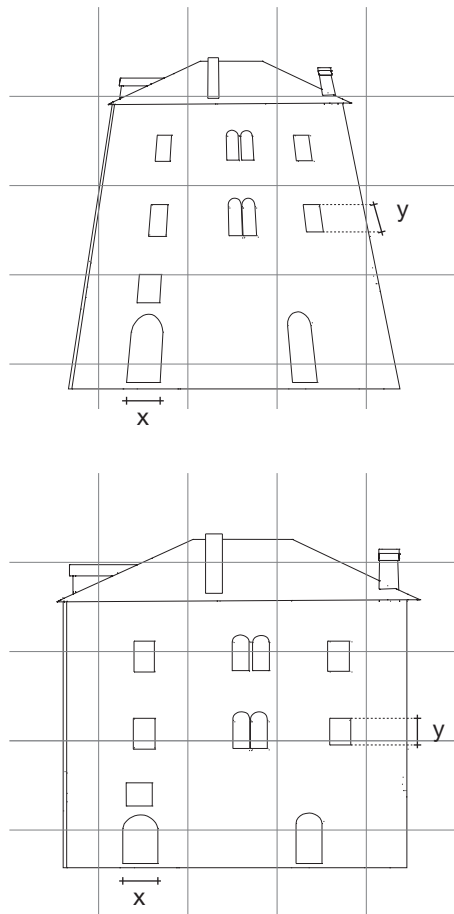

### Rectification through Geometry

One of the possibilities of rectifying an image is through geometric rectification. This can also be achieved through less specialized software programs, for example through image processing software. Based on the program, a raster can be superimposed on the image. The raster itself can then be configured so that the image can be oriented on the basis of the raster. Specialized programs can ensure that the raster is associated with true measurements. As long as the measurements taken from individual sections of the photographed object are known, the image can be rectified relatively true to scale. Prerequisite for the geometric rectification is, however, that the distortion present in the original image be minimal. If the perspective lines of the image are too skewed with respect to their normal focal relationship, the geometric rectification will be imprecise. The advantage of geometric rectification is the simplicity and speed of the process. No particular measuring instruments are required, only suitable photographic documentation need be available. In these cases, the process can also make do without expensive, specialized photogrammetric software.

However, geometric rectification can only achieve a relatively low degree of accuracy. It is thus inadvisable to attempt to derive accurate measurements from the rectified image itself. A geometrically rectified image can also not be reliably linked with a tachymetric survey plan (► Chap. D.2). Planes at varying depth (for example, the surfaces of a building and the rear of a staggered, recessed balcony within the same) can only be combined into a single rectified mosaic with considerable effort.

### Rectification by Means of Reference Points

Rectification by means of reference points is thus a more suitable method for measured building surveys. In contrast to geometric rectification, the image is rectified based on tachymetrically calibrated coordinates. The rectified mosaic is therefore based on the fixed points available for a given space, and not on the geometry un-

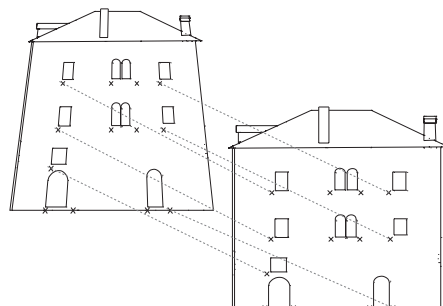

derlying a particular image (► Chap. D.2). Any deformations on the object in question are thus also considered. To some degree, rectification by means of reference points offers the possibility of extrapolating measurements from the rectified image, of converting the image into a line drawing according to a particular scale, or of linking the two.

An additional advantage of this method is the possibility of condensing various planes, for example of a surface, together into a single rectified mosaic, allowing not only the front plane to be rectified, but also the areas towards the rear to be projected onto the image plane orthogonally according to scale.

#### Overall Procedure

Rectification by means of reference points is a step-by-step procedure. The number of steps is based on the image planes identified for the building to be measured. One image plane is equated with one layer. Layers can in turn equate to planes of a facade or similar structural level. Assuming that a facade contains windows recessed into deep-set embrasures, one image plane will be represented by the front area of the facade, while the window plane will represent the next image plane, and so forth. Layers which lie in the same plane should always be identified and grouped together in the same image plane. If the facade to be rectified includes both a front plane and lightly recessed plane including the windows, this would require two image planes. The rectification would thus proceed in two steps. The first step would be the rectification of the front image plane, followed by the rectification of the rear image plane. The layers should thus exist as separate images. Any overlap which may arise between the two planes can be removed later as appropriate. The individual image planes can thus be merged together to form a single orthogonal projection.

#### Planning the process

Before the creation of each rectified mosaic, the exact sequence of the procedure needs to be planned and coordinated in order to avoid the necessity for any unneces-

sary additional work later. In addition, the object to be measured should be checked for its suitability for the process.

Several factors can make an object unsuitable for this method. Objects which contain heavy reliefs can only be assembled into a single rectified mosaic by means of numerous images, there should not be too many outward projections or backsets such as deep embrasures, balconies, protruding bays, etc.

The position from which the photographs are made should also be established in such a way as to allow for a clear view of the object. The intrusion of foreign objects such as vegetation represents a subsequent loss of information for the rectified mosaic.

The position from which the photographs are taken should, on the one hand, be chosen so that as much of the object can be included on a single image, reducing the need for taking numerous partial images. On the other hand, it should be chosen so that (vanishing) lines on the image do not converge excessively through the distorted perspective, that is, the camera angle should not be too large. The closer the photograph is taken from the object, the greater will be the camera angle.

Due to the necessary distance between the photographer and a larger object which needs to be photographed, attention should be paid that the camera provides a sufficiently high resolution. The larger the details of the photographs can be enhanced, the fewer individual images need to be combined per image plane. The resolution should be high enough so that the reference points can still be recognized even on a larger image section.

#### Determining Meaningful Reference Points

Reference points need to be determined on the object to be photographed. These can be calibrated in a later step tachymetrically and thus be associated with x-y-z-coordinates. With the aid of these coordinates, the photograph can be linked with spatial data. On this basis, the image can be rectified in an x-y-direction using real measurements. Specifically, this means that easily visible points need to be determined on

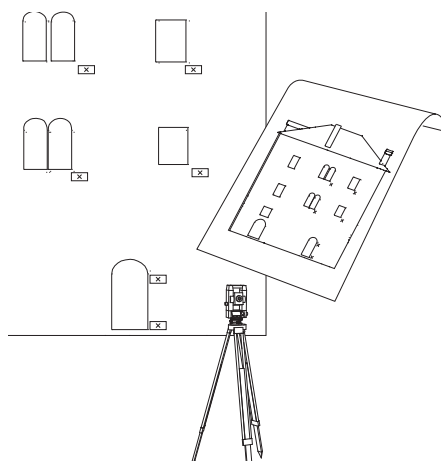
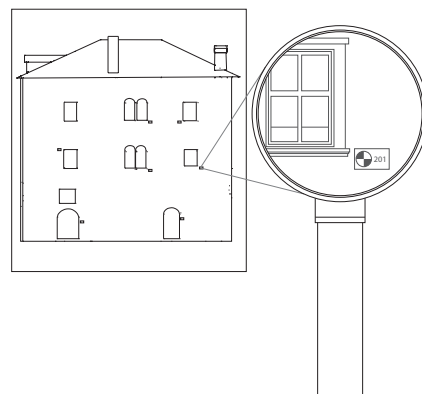

the object, which can both be measured by using a tachymeter and re-identified on the image. Suitable reference points can be provided by prominent areas on the object itself (such as the corner points of window embrasures) or separately marked points. In the case of separate markings, care should be taken that any markings are also reversible.

In order to ensure a dimensionally accurate rectification free of errors even on any edges, the reference points should be distributed equally across the object. It is particularly important that the reference points be located near edges and corners of the object as well. Should the rectification only be carried out on the bases of several image planes (for example with larger projections or backsets on facades), this rule applies to each individual image plane. The larger the object, the more reference points will be needed. It is worth being generous with the measurement of reference points. The more points which can be used in rectifying the image, the more accurate will the results be.

In order to maintain an overview of the distribution of the points, it may also be worthwhile to map them onto a sketch of the object. The simplest means of doing so is to use a printed copy of a photograph of the object.

#### Taking Photograph(s)

Every high-resolution camera is fundamentally suited for image rectification. Attention should be paid when photographing larger objects to keeping control points, which can be quite small, recognizable on the image. The photograph should allow for an exact assignment of the control points. The camera should thus ensure that even measurement points no larger than a few millimeters are still visible in the photograph. When photographing under difficult light conditions, it may be advisable to use a tripod.

#### Measuring Reference Points

The measurement of reference points works in the same way as the measurement of control points (► Chap. D): after the tachymeter (total station) has been fixed into

position, the individual points previously marked onto a sketch or photograph are measured. The designation of these points should help to find them again easily on the photograph. Ideally, the data will be transferred directly from the tachymeter to the CAD-file on the laptop on which the image will later be rectified.

#### Importing into the CAD-file

The relevant software for creating rectified mosaics also includes an interface between CAD and hardware, that is, the tachymeter. Normally, the data should already be available as a CAD-file after the measured survey has concluded.

The photographs to be rectified should now be loaded into the same file which also includes the reference points. The program can now overlay the rectified image over the control points after running the process.

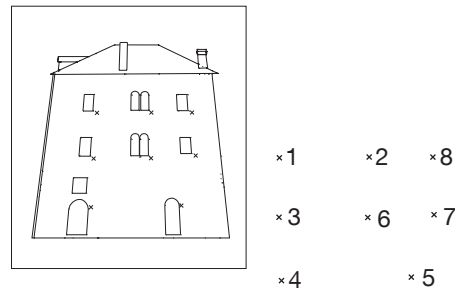

#### Merging Reference Points onto a Plane

Following the building survey, reference points should be available as three-dimensional data. Since the depiction of the measured survey as a plan essentially requires an orthogonal projection, the reference points need to be merged onto the image plane, that is, projected orthogonally. This means that the x-y-z-coordinates need to be reduced by one dimension.

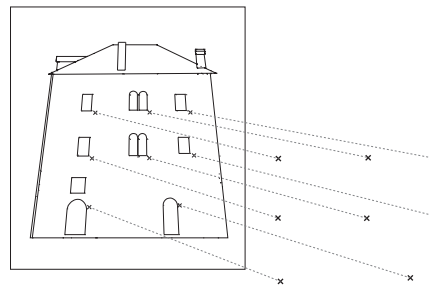

#### Assigning Points and Image Rectification

The actual process, attaching reference points to the photograph, can now begin. The points should be visible in the CAD-file, alongside the images which need to be corrected for distortion. The process can start by consulting the sketch drawn to indicate clearly the location of the designated points on the image. Each reference point in the CAD-file can now be associated with its equivalent on the image. Either markers with relevant numbers were used as reference points, or “naturally” occurring points on the object. The process of associating the points with the CAD-file is specific to each software. As soon as all of the points have been linked accordingly, the photograph can be rectified. Normally, the program can then

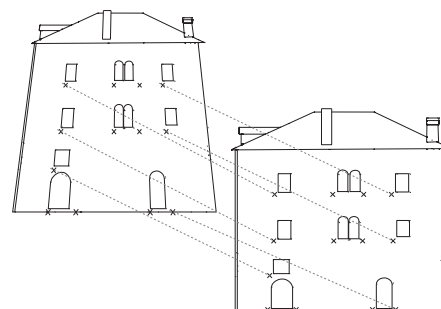

overlay the rectified photograph over the reference points in the CAD-file. The rectification leads to a trapezoidal distortion of the image borders.

Joining Individual Images, Removing Imprecise Sections of the Image

In most cases, a single photograph will not be enough to generate a rectified mosaic. This must be composed of several partial images if the object, for example, cannot be depicted in its entirety on a single photograph or parts of the object are obscured. The partial sections must then be photographed from different angles. The same also applies when the object to be depicted is staggered in depth, for example in the case of a facade with projections or backsets.

The photographs are all loaded into the CAD-file together with the reference points. The best procedure is to proceed step by step: the foremost plane should be corrected for distortion first, followed by the the plane directly behind. The program will rectify all of the images in the same way. In the final result, the images will partially overlap. It is recommended

that the images of the hindmost planes be cropped before they are imported into the CAD-software. If, for example, the rear wall of a recessed balcony is inserted into an orthogonal projection, it can be recommended that the image be edited as far as possible beforehand to isolate the relevant details. Doing so means that the rectified images will not overlap too much and it will be easier to orientate oneself within the composite put together from the individual images when editing or cropping. Cropping, that is the removal of non-relevant details of the image, is a function offered by most relevant software programs. This requires only that the desired end result be determined in outline. This is particularly important when the rectified image is to be inserted into a larger plan, since non-relevant sections of the image should not cover other content indicated by the plan. Here we can again point out that surfaces located outside the boundaries of the outermost reference points are not reliably rectified, but rather in part heavily distorted. These are thus not accurate to scale, it is again advisable to crop them out of the image accordingly.

*West view of the “Unterer Yngramhof” before and after the correction of the image for distortion and the assignment of reference points: lighter-colored areas are located significantly in front of or behind the plane of rectification and are thus not true to measured scale.*



### 3. Further Methods

Photogrammetric methods which are based on more than one image can also yield spatial information without requiring additional measuring points or data. Reference measurements are only needed to determine a correct scale for the recorded object.

#### Stereophotogrammetry

The method is based on simple geometric principles, similar to those which apply to the human body: seeing with two eyes (stereoscopy) creates a spatial component beyond the mere image itself.

The same applies to the technical field: if focal length and camera position are known for two overlapping recordings, their spatial position can be calculated by identifying equivalent points on both images.

Originally, the points had to be assigned manually. Today, image algorithms are used to accomplish the same task, which can recognize and assign points automatically.

Stereophotogrammetry is commonly used in particular for terrestrial surveys and for generating maps, whereby the necessary information is provided through aerial imagery. In architecture, the method is also commonly used for the documentation of facades. Insofar as the facades are overall even, it is, however, more customary to use the quicker and generally adequate method of generating orthophotos from individual images, as described above.

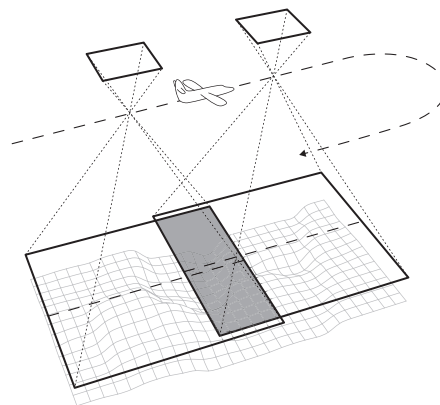

*Stereophotogrammetry: Basic principle shown by example of a terrestrial survey on the basis of aerial imagery.*

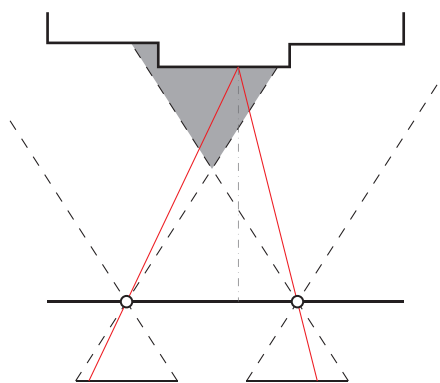

*Stereophotogrammetry of a house facade.*

*Multi-Image Photogrammetry: Generation of a three-dimensional model on the basis of several photographs taken from different locations.*

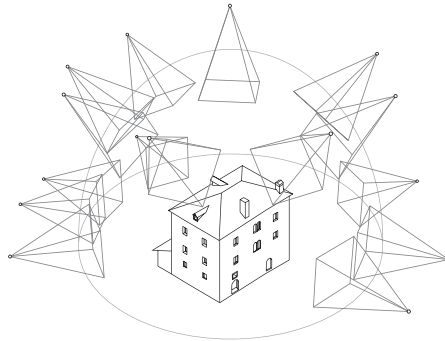

*Scaling of a 3D-model by means of reference measurements as well as correct orientation through measured geodetic values.*

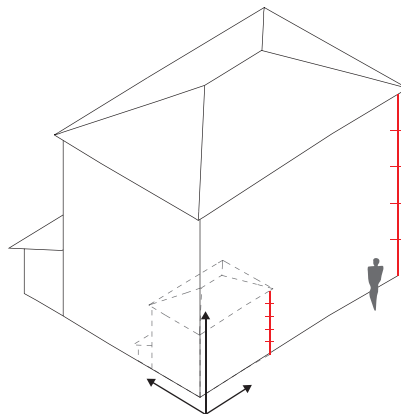

### Multi-Image Photogrammetry

The more images can be taken of an object, the more accurately can a three-dimensional model be generated. Software available today is able to calculate the camera positions in space at the time images were taken and to place them in relation to one another by using the digitally stored image data, particularly the focal length. The automatic recognition and assignment of equivalent points allow for the geometry of the target object to be precisely determined and generated. This process is today also known under the term "Structure-from-Motion" (SfM).

The color and tone values of the image can also be used to overlay the object with the appropriate textures, through which a virtual model can be generated within a short period of time. The subsequent processing of these models offers a range of further possibilities, including the fast creation of sections through the model. This high degree of flexibility is gained at the cost of large amounts of data as well as of the high processing power required and the appropriate technical equipment.

Scaling the object to the required measure and determining its spatial orientation also require recourse to known or additionally determined reference measurements or values. Based on the given requirements or intended use, the model can also be integrated into a geodetic system, that is, geo-referenced.

As a method, photogrammetry is of course also used in many other areas beyond architecture and terrestrial survey, particularly in industry, vehicle and machine manufacturing, medicine, etc. Both hard- and software in this field are thus constantly being developed and adapted for various applications, not only by the software companies, but also within the context of research projects.

# Planning a Comprehensive Building Survey

---

## 1. Project Organization

As previously mentioned, depending on the scope and intended purpose, a building survey can encompass not only the survey measurements, but also an investigation and catalog of the building's features, room data sheets, and maps. Archaeological soundings are also often included, as are scientific studies and examinations of the secondary literature and relevant archives. While the latter can be conducted independently outside the timeframe of the survey, the measurements themselves are most often carried out at the beginning of the project.

The planning procedures heavily depend on the type of property to be surveyed and the research goals. In general, the property should first be inspected and the overall size and complexity of the site determined. An initial visit to the site can be scheduled for this purpose, during which the rough dimensions can be recorded, the property can be photographed, and sketches drawn. During this first visit, the goals and scope of the project can also be discussed with the client, including an agreement on the desired accuracy of the survey and the resulting scale of the plan drawings. Access to the property and any possible hazards should also be clarified. Following the visit, survey planning can begin by determining the working methods to be used according to the size, complexity, and accessibility of the property as well as the required outlay of time and material (as necessary, also in consultation with other members of the project). Only after an estimate has been made of the time and material required can a cost estimate be drawn.

Since building surveys generally take some time and can only partly be conducted at the same time as other work on the property, project planning should allot sufficient time. It should be noted that, in

some cases, establishing the measuring grid – especially mounting the fixed reference points – needs to be coordinated with other work on the site, particularly if some surfaces are to be removed as the project progresses. Depending on the property and methods used, the building survey can be conducted more efficiently if the floor plans and sections/views are measured in separate steps. It is, however, also possible to take all points needed in every room for both section planes and to work simultaneously on multiple plan drawings if this is conducive to more efficient progress for the overall survey.

In the same way as the room data sheets, the features can be studied and the catalog created at the same time as the survey measurements as soon as an overall plan drawing is available for locating the features and individual rooms. Openings made to expose particular features and floor sections for foundation excavations should be supervised by a specialist, since finds associated with the features can otherwise be easily overlooked or destroyed. The results should be entered into the plan drawings.

In addition, the building survey should absolutely keep a project logbook which contains all measures undertaken, work steps, and reasons for taking particular actions, and which documents the work so that all measures can be retraced and understood later. Anything noteworthy, any problems, open questions, and any features should also be entered into the logbook in order to facilitate analytical reports composed at a later date. The logbook can be written by hand and supplemented on site by sketches, or it can be kept as a continuous file on the computer together with any relevant sketches or photographs.



Example pages from a feature catalog for the former Cistercian Abbey of Bebenhausen, west wing (strebewerk. Architekten GmbH, Stuttgart).

Befundkatalog Tübingen-Bebenhausen, ehemaliges Zisterzienserklöster, Westflügel

009: Kreuzgang  
 Bauablauf des Kreuzgangs. Befundblatt 1

009d\_B1

Beschreibung:

- die nördlichen zwei Strebepfeiler haben keinen Schweifgiebel und entsprechen damit den Strebepfeilern des Nordflügels
- das Sockelgeschoss verjüngt in diesem Bereich nach Süden leicht nach unten und ist in den südlichen Jochen nach Osten abgeschägt
- regelmäßiger Sandlagerschnitt des Sockelbaus in den südlichen Jochen
- im Gewölbe befindet sich eine zusätzliche Gurtstippe sowie Meisterzeichen und ein Wappenstein

Interpretation:

- Bau des Kreuzgangs von Norden, Osten, Süden und zuletzt Westen
- (s. Dissertation M. Köhler, 1998, S. 244f.; S. 148f. ff) und S. 149f. ff) im Ost- und Südflügel
- die Gestaltung wurde während des Bauwerks der vier Kreuzgangflügel geändert
- der Kreuzgang wurde zwischen 1471 (s) bis um 1500 errichtet

strebewerk, Schöbel Regler Lippig Partnerschaft Dipl.-Ingenieure Stand 01.09.2008, Seite 43

Befundkatalog Tübingen-Bebenhausen, ehemaliges Zisterzienserklöster, Westflügel

152: Dachstuhl über Kreuzgang  
 ehemalige Dormerfenster

152\_B1

Beschreibung:

- In der Ostwand befinden sich im Flur zugesetzte Wandnischen; diese sind über dem Kreuzgang als ehemalige Fenster zu erkennen
- im Kreuzgangdachstuhl sind an die Ostwand mehrere Dachansätze und Dachkonstruktionen ablesebar
- am liegenden Stuhlanker des Kreuzgangdachstuhls befindet sich ein Zapfenloch, das auf ein fehlendes Kopfband Richtung Norden hinweist

Interpretation:

- es lassen sich drei Bauphasen ablesen:
- 1280: bauzeitliche Fenstergliederung, unterhalb des Gesimses unter den Fenstern schließt ein Pfälzchen mit offener Dachstuhlkonstruktion an. Über die Konstruktions des ersten Kreuzgangs lassen sich keine Aussagen machen
- um 1520: die Fenster werden durch den Neubau des Kreuzgangs mit der verbundenen Dachaufhebung bis ca. zur Hälfte zugestetzt
- bei weiteren Umbauarbeiten um 1780 wird das Dach in der heutigen Form angeschiffet

- die bauzeitlichen Oberflächen sind noch erhalten: um 1280 steinsichtiges Bruchsteinmauerwerk mit Wandöffnungen aus Werkstein; im 16. Jahrhundert mit der ersten Anhebung des Daches verputzt mit farbig gefassten Werksteinen

Legend:

- Dachansatz und Oberflächen um 1280 (d)
- Dachansatz und Oberflächen um 1520 (d)
- heutiger Verlauf seit 1780 (d)

strebewerk, Schöbel Regler Lippig Partnerschaft Dipl.-Ingenieure Stand 01.09.2008, Seite 43

Excerpt from a sketch book for work on Santa Maria dei Miracoli in Venice: important features can be noted on site or can, for example, be entered onto pre-existing plan drawings.

Handwritten notes from the sketchbook:

*Stollenbauweise*

- Innen Putz mit Putzschichten unter +
- Putzschichten: Corning 1. Stockwerk, Putzschicht
- Putz und Bruchstein → 15% Mauerwerk
- Putz = Corning 1. Stockwerk 0-15%
- im 16. Jhd. Putz → Corning
- Tüpfelstruktur → 3-4 mm nur auf Stein?
- Putzschicht mit gelbem Feinwand
- Putzschicht 15% Mauerwerk

Corning besteht durch Anhebung der Luft für Aufspannen halten, bei der Struktur gegen sich

- Teile der Putzschichten (15%) in Höhe der Bruchstein Schichten 15% →
- 3. Putzschichtung d. Putzschicht 15% bis 10 mm bis die 15% Tüpfelstruktur
- Putzschicht 15% Mauerwerk
- Putzschicht 15% Mauerwerk

## 2. Feature Analysis and Feature Catalog

### Features

Features refer to any structural evidence for construction, age, time of construction, or the chronological sequence of construction work. These can, for example, consist of building seams which might suggest a subsequent addition of part of a building, or an added window or door opening which points to a later alteration. By exposing underlying support structures, the study of construction features can, for example, help to clarify the methods and materials used in construction.

In addition to construction features, the survey may also sometimes encounter object finds such as coins, containers, and other objects of daily use, sherds, the remains of textiles, printed papers, etc. These are often preserved near or on blind floors, openings which have been added later, and hard-to-reach timber connectors and are to be treated as archaeological finds. The exact position of the find should be mapped onto the plan drawing. The find should be designated with a find number and documented in the form of descriptions, drawings, and photographs. Afterwards, the find should be archived.

Depending on the nature of the features and the condition of the building, features can either already be visible before work begins, or may first need to be exposed by special methods of investigation. The excavation and analysis of the features should always be carried out by trained specialists.

### Feature Analysis

The investigation of features during restoration work sometimes makes use of so-called stepped layers, which involve the removal and documentation of the surface of a building element layer by layer from a small area of the surface. This method can help to establish a stratigraphy, that is, a sequence of surface layers which yield information on the layers of paint or plaster. The analysis of these layers for coloration, composition, material, etc. can also provide information on the history and use



*Stepped layers ("Be-fundtreppe"): minimally invasive examination of paint features in the historic structure of a building.*



*Sequence of layers of a wall and ceiling in the corner of a room used to establish their chronological sequence.*

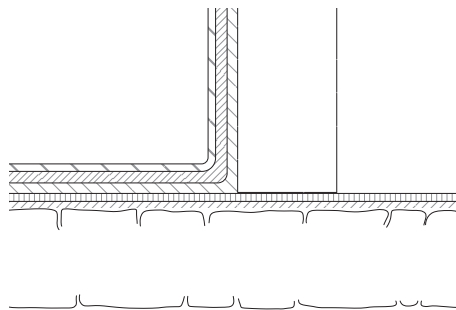

*Drawn documentation of the sequence of paint layers on a wall connection.*

of a particular room. Evidence can also be drawn for the time of construction and period of use of the particular configuration. The layers are assigned numbers from bottom to top (old to new). For a systematic analysis, multiple layers of paint or features in the building need to be synchronized. Characteristic layers, such as those which have been assigned a fixed date through connection with a dated door frame, can then be used to provide crucial information for dating.

Smaller openings made to expose individual features and meant to provide clearer information on building structures in walls,

*Example for a foundation excavation of a well system (top view, section); the individual strata (the sequence of layers) can clearly be read from the section.*

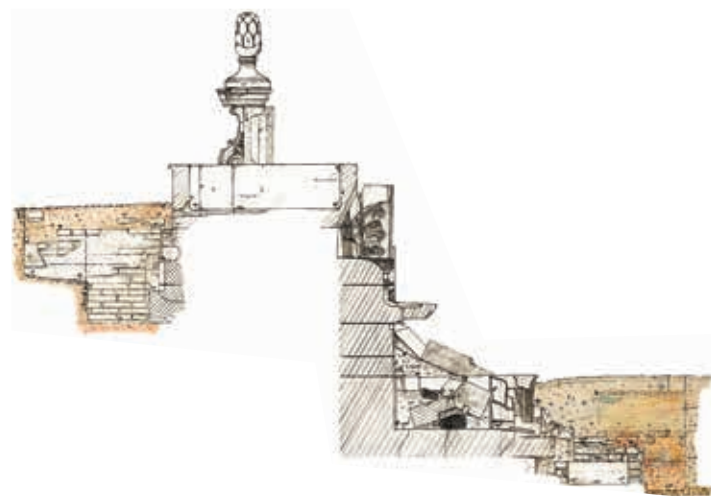
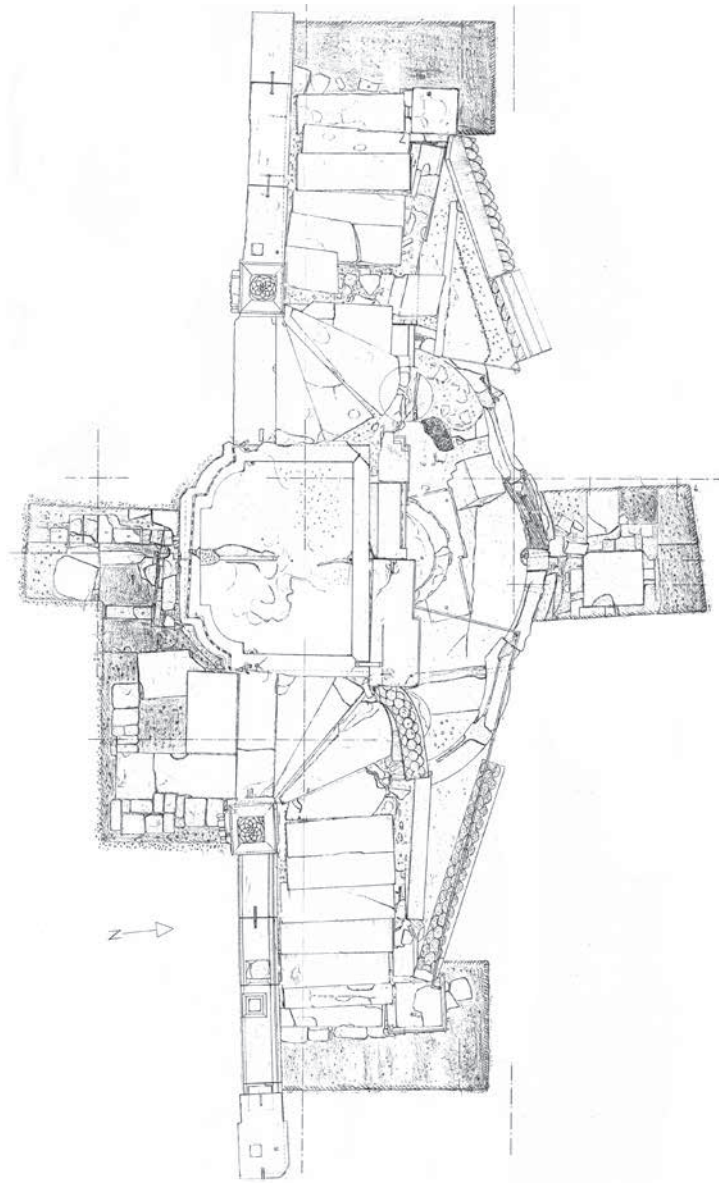

floors, and ceilings can also be expanded. This should, however, always be done carefully, and the opening should be kept as small as possible and restricted to areas where no valuable surfaces will be damaged.

#### Foundation Excavations

Foundation excavations serve to provide additional information on the initial construction and to assess the building method and capabilities applied in laying the foundations of a building. In order to carry out this work, it may be necessary to apply for formal approval from the responsible building authority. Technically experienced specialists such as architectural historians or designated archaeologists cut small soundings at several locations perpendicular to the exterior walls. These cuts are then expanded layer by layer until the lower edge of the foundation is clearly visible. The excavation trenches should be evened down vertically and cleaned, so that the foundation trenches, underfill, etc. can be read distinctly. The excavation trench should be drawn, possibly also in color if the soil findings require. The trenches should ideally be integrated into the building survey. Finds should be mapped, carefully labeled and archived, and, if necessary, discussed with a relevant specialist.

#### Feature Catalog

In contrast to a room data sheet, which aims at a complete and systematic documentation of all surfaces of a building, the feature catalog only records selected findings which are characteristic of the building under examination and directly relevant to the current project. The feature catalog reflects the building's main characteristics and makes no claim to providing complete and comprehensive documentation.

An overview plan in which the individual rooms are numbered, which shows the viewer with what room any features are associated, is important for locating any features. Room numbers should be assigned as an alphanumeric code according to the following scheme:

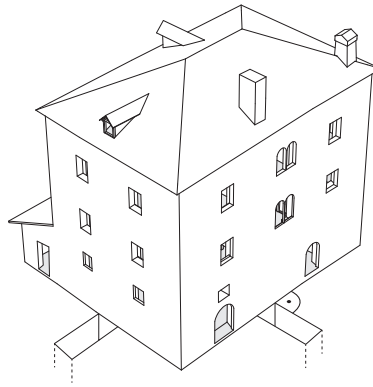

*Foundation excavation:  
Cuts perpendicular to the  
wall, never parallel to the  
course of the wall!*

1. place: building part (letter)
2. place: floor (number)
3. place: room (number)
4. wall (lettered clockwise from north: a, b, c ...)

A detailed explanation of how to assign room numbers can be found in the section on room data sheets (► Chap. F.3).

In order to define the features more precisely, these should be assigned not only a room number but a feature number. Feature numbers can either be assigned continuously or numbering can begin again to designate features in each room.

#### Thematic Structuring of Data

The feature catalog will ideally be presented as a table on a form sheet so that similar information can always be entered in the same place and format and thus remain clearly legible and easy to find. The feature number should always be entered onto the data sheet at the top right in order to optimize use of the catalog. It is important to locate the feature on an overview plan. Features are documented through a combination of short, descriptive texts using important keywords, informative photographs of details which include a scale and the feature number, and also, optionally, drawings made to scale. Depending on the project, the proportion of written texts to images may vary. The feature catalog can provide a good basis for cost estimates for renovations.

Example pages from a room data sheet for Meersburg (strebewerk. Architekten GmbH, Stuttgart).



Example pages from a room data sheet for Schloss Kirchberg/Jagst (strebewerk. Architekten GmbH, Stuttgart).

Raumbruch		Schloss Kirchberg/Jagst, Marzell	
Ma-EG01			
<b>Befunde</b>	Ma-EG01	Geschoss	EG
Raum	Ma-EG01	Geschoss	EG
Raumgröße	~ 5 m²		
Aktuelle Nutzung	Treppenhaus (Ma-Tr-10G) mit Vorraum (Ma-EG01)		
Wand Ww	Holzverkleidung bis ca. 2,00 m Höhe, oberhalb Tapete		
Wand Wb	Offener Durchgang, d.h. Wand Wb nur als kurzes Stück entlang des unteren Treppenauflaufes präsent, dort verputzt, gestrichen		
Wand Wc	Tapetiert		
Wand Wd	Verputzt, gestrichen		
Böden	Fliesen		
Decke	Verputzt, gestrichen		
Fenster/Türen	1 Fenster an Wand Wd (auf Höhe des Treppensockels); Holztür mit Oberlicht an Wand Wb (Ma-T-W-EG01) Abb. 2), die zu einem kleinen Hof an der Westseite des Marzells führt; Kellertür (Ma-T-UG01) liegt etwa hälftig unterhalb des Raumbodenniveaus in Richtung Wc, erreichbar über eine anebnfluge Treppe (Ma-Tr-EG)		
<b>Anmerkungen Bauforschung</b>	Die heutige Treppe entspricht einem modernen Einbau ebenso wie der Einbau des Fensters an Wand Wd auf Höhe des Treppensockels. Zwei Grundrisse aus den 1950er Jahren geben den eines umgekehrten Verlauf des Anstiegs wieder sowie eines Kaminschachts in Wand Wc, der in etwa dort verläuft, wo sich heute genanntes Fenster befindet (dieser Fenstereinfassung wiederholt sich im Stockwerk darüber). Der angegebene Abbruch der Treppe im Plan aus dem Jahr 1955 ist bis zur Planung von 1957 noch nicht ausgeführt, sondern der noch unveränderte Zustand verzeichnet (vgl. Grundrisse EG, Baugesuch 01/1955 und 10/1957, Kirchberg Baurechtsamt). Der Anstieg auf der Wandseite mit der noch in den 1950er Jahren verzeichneten Treppe dürfte dem bautechnischen Bestand entsprechen haben, wie er auch im Grundriss von 1829 festgehalten wurde (vgl. Planatz 1829).		
<b>Weitere Anmerkungen</b>	Raum Ma-EG01 und Ma-EG02a gehen annähernd flächend ineinander über; eine dreistufige Treppe markiert den Übergang (Abb. 3) und Wand Wb existiert dabei nur als kurzes Stück entlang des unteren Treppenauflaufes von Ma-Tr-10G.		

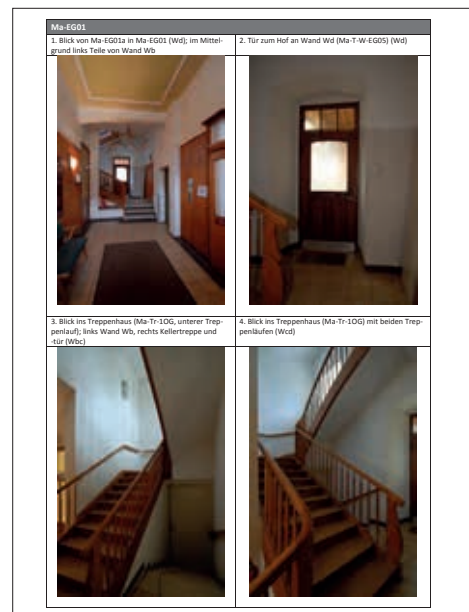

### 3. Room Data Sheets

Room Data Sheets provide a systematic overview of the constructional and decorative properties of an entire building, organized room by room. Over the course of a project, all work phases can be noted in the data sheets, from the inventory of the current state of the property, work proposals, or steps needed for safeguarding the property, up to the addition or removal of construction details. The documentation is recorded through short written descriptions, informative photographs, and

sketches drawn according to scale. This forms part of the archiving and to some extent the publication of the findings. Room data sheets can also serve as a basis for cost estimates. Room data sheets should be kept particularly for complex projects, which often continue work of over a century. Because of the large amount of time needed for creating and keeping comprehensive and systematic documentation, it is advisable to weigh the benefits of doing so for planning and

carrying out a project at the beginning. The creation of room data sheets in Germany is regulated by a set of guidelines devised by the Association of German Engineers (Verein Deutscher Ingenieure or VDI; Guideline 3817). It should, however, be noted that a reasonably useful structure for the documentation of an existing building should always be adapted to the requirements and goals of a particular project. The general guidelines can only be understood as providing a first basis for documentation.

#### Standard Data Sets

An intuitive depiction of individual phenomena and a meaningful integration of information into a quickly and easily comprehensible standardized data set are both crucial. Room data sheets often tend to develop into large, unfiltered collections of data which can be difficult to manage. Systematic processing of the data is the only way to ensure that the data sheets can serve as a useful tool. This includes the determination of a standard data set, which can slightly vary from project to project, but which should essentially combine three main types of content:

- Description of the entire building property together with the assignment of room numbers,
- Description of the constructional composition of walls, floors, and ceilings, including special features and facilities such as technical equipment or other facilities intrinsically connected to the site,
- Description and depiction of surfaces and signs of wear or use. During renovations, surfaces are often heavily altered or removed. The prior state of the building should thus be thoroughly documented beforehand.

It is essential that the location of each of the rooms described should be indicated on the general floor plan. A fold-out plan drawing can serve as an additional orientation to the rooms marked on the systematic floor plan on the data sheet, particularly when dealing with larger buildings or with a site composed of numerous individual buildings or sections.

#### Room Numbers

Room numbers allow for a transparent designation of a room and provide a good basis for the systematic organization of the site inventory. Room numbers usually consist of multi-digit numeric or alphanumeric codes. The first position in the code usually refers to the floor of the building, whereby 0 represents the groundfloor, 1 the first floor, etc. Basements or lower stories are indicated by negative numbers, accordingly. If the site consists of several distinct building sections which can clearly be distinguished from another, a prefixed letter or a number can be used to indicate the respective sections.

Two different systems have become customary for assigning room numbers within a floor. The first possibility is to number all rooms consecutively clockwise, beginning from the north. The second is to number all of the rooms in the order of their documentation. The number 1 is used to indicate the room directly behind the main entrance or entryway to the building. Whatever system is used, it is essential to follow a consistent method of assigning and recording room numbers within the layout plan. Once this is done, the walls should also be designated, using the compass directions as a guide: a for north, b for east, c for south, and d for west. Combinations of these letters can also be used for intermediate positions, such as ab for northeast, etc.

As an example, the standardized code „A0.12b“ can be read as follows:

A designates the part or section of the building.

0 designates the ground floor.

12 designates the consecutive numbering of the room (within the floor of the building).

b designates the east view within the room.

Doors and windows can either be numbered continuously for the entire project (window W1, W2, W3... and doors D1, D2, D3...) or separately according to the individual room or wall (for example, window A0.12W1a, 0.12W2c, etc.; doors labeled with D, accordingly).

### Example Template for the Structure of a Room Data Sheet

<b>1. Property</b>	Address, information on the property owner, as needed
<b>2. Exterior</b>	<p><u>2.1 Setting</u></p> <p><u>2.2 External grounds or facilities</u></p> <p><u>2.3 General layout overview</u></p> <p><u>2.4 Facade</u></p>
<b>3. Interior</b>	<p>General layout with all rooms and room numbers, beginning with the ground floor, numbered by floor either clockwise or according to the sequence of documentation.</p> <p><u>3.1 Documentation of individual rooms</u> Room numbers and basic measurements, size (m<sup>2</sup>), height, location within the general layout (floor plan).</p> <p><u>3.1.1 Walls</u></p> <p><u>Construction</u></p> <p>Masonry (e.g. baked brick, quarry stone, ashlar, graywacke)</p> <p>Masonry bond (e.g. header, block, stretcher, monk bonds)</p> <p>Timberwork (e.g. log construction, timber frame, mullion and transom construction)</p> <p>Infill (e.g. wattle, cob, dunnage, baked brick, brick)</p> <p>Reinforced or exposed concrete (e.g. board-marked, polished, masonry finished, washed)</p> <p>Drywall</p> <p><u>Surface</u></p> <p>Material (e.g. natural stone, ceramic tiles, wood paneling, wainscoting, plastering, wallpaper, paint, colored facades or wall paintings)</p> <p>in each case including description and details of height above the fixed floor from beginning to end of section.</p> <p><u>Openings</u></p> <p>Windows (e.g. double casement window, pivot window, skylight, glazing, material)</p> <p>Doors (e.g. panelled frame doors, ledged doors, material)</p> <p><u>Additional observations</u></p> <p>Transition areas to floor or ceiling</p> <p>Technical fixtures</p> <p>Damages</p> <p><u>3.1.2 Ceilings</u></p> <p><u>Construction</u></p> <p>Timber (e.g. beam ceiling, paneled ceiling, box girders)</p> <p>Massive ceiling (e.g. brick, concrete)</p> <p>Vaulting (e.g. Prussian vaulting, barrel vaulting, cloister vault, groin vault with or without ribs)</p> <p>Surface (e.g. earth, natural stone, plates, ceramic tile, brick, pavement, terrazzo, PVC, linoleum, wooden floor boards, parquet, carpeting)</p> <p>Other observations</p> <p>Technical fixtures</p> <p>Damages</p>

### 3.1.3 Floors

Construction

Surface (e.g. earth, natural stone, plates, ceramic tile, brick, pavement, terrazzo, PVC, linoleum, wooden floor boards, parquet, carpeting)

Format (cm), Farbe, evtl. Muster / Gestaltung

Other observations

Technical fixtures

Damages

### 3.1.4 Fixtures

Type

Short description

Location

### 3.1.5 Depending on the project, information on

Current use

History of construction and use

Available archival material, plans, documents

Evaluation of the building as a historical monument

Findings on restorative measures

Architectural concept

Findings from structural analysis

### 3.1.6 Photographic documentation of each room

All photographs should include a photo board and a scale.

### 3.2 Roofing (ideally including for each case schematic drawing and location on the general floor plan)

#### 3.2.1 Trusswork

(map results of tests for load capacity as well as any damages)

#### 3.2.2 Rafters

(map results of tests for load capacity as well as any damages)

#### 3.2.3 Purlins

(map results of tests for load capacity as well as any damages)



Photo board

a) prepared with adjustable panels



b) easily legible on the photograph so that the image can later be clearly associated with the section of the room depicted.



#### Processing the data

The room data sheets should be designed in such a way so that all of the information can be made available quickly and legibly. For this purpose, the data sheets can be structured in tabular form, in which each element is assigned its own field, so that the same information for different rooms can always be found at exactly the same place. It is particularly useful to specify the terms which will be used in the descriptions, so that this information is as standardized as possible. This can be achieved in most word processing programs or databases by using drop-down menus, pre-defined options, or specific written standards when the fields are filled in manually. The shorter and more concise the descriptions, the greater will be the utility of the room data sheets. Room data sheets can basically be prepared manually on site or with the aid of a computer. The continued development of information technologies makes it possible to prepare digital room data sheets as databases with specialized input forms, which can in turn be edited either offline as interactive pdf-forms or online as applications accessed through mobile devices.

The choice of method depends on the building property and on the working conditions on site. The room number should be placed at a prominent position in the table or entry form, for example in the upper right corner or in a header marked with a different color, since this will be the first essential reference point. General information on the room and its location within the overall floor plan should form part of the next section. The documentation should follow next, which can be divided into smaller tabular blocks and structured according to the goals of the project. It may thus be useful to describe each room as a whole, without going into details for every wall, or it may be useful to highlight particular details. Centrally stored digital databases of room data sheets simplify the process of updating the necessary information over the course of the project by various members of the project staff. They also reduce the risk of data loss when the data is transferred or copied to other members of the project and they permit additional files to be attached, such as archival material, literature, historic images or plans, or any site assessments which may have been composed earlier. The final photographic documentation supplements the description. It is important that all photographs are associated not only with the identification code of the room or wall but also with a specific compass direction.

#### Photographs and Photo Boards

As a rule, the comprehensive photographic documentation of a room includes six long shots: two diagonal shots to record the geometry of the room and its spatial contexts, four frontal shots of the individual walls, including connections to neighboring walls, floors, and ceilings. The documentation of the enclosing walls can be supplemented by additional pictures, which should ideally include as large an area as possible. Windows, doors, and characteristic features can be added through detailed views or close-ups. It has been practical to use a folding panel board, which can easily be manufactured from a spiral-bound notebook or pad. In

general, attention should be paid that the images are distorted as little as possible. Even lighting of a room and long exposure times are to be preferred over flash photography.

Over the course of a project, a large number of photographs will often be taken. If these are not managed in an organized fashion, it will become difficult to correlate them with the desired information. It is thus advisable to include the most important information within the image itself, since these data cannot be lost even if the associated files are renamed. Information which should be considered includes: a scale (e.g. a measuring rule integrated into the image), a north arrow, where appropriate, the room number, the wall number, date, and name of the property. If the photographs are taken digitally, particularly when the property contains a large number of rooms, care should be taken to balance image quality with the size of the resulting files. Attention must also be paid to good archivability of the photographic material as well as to the assignment of comprehensible file names and file structures.

#### 4. Mapping and Construction Phase Plans

Survey plans are often used as a further basis for mapping, since maps of damages and additional measures are fundamental to every restoration. Maps usually include information on materials, damages, and any associated measures to be undertaken. Maps of metals or stones, for example, are common. The latter usually show the diverent types of natural stone within a building, and thus can also show how particular types of stone were deliberately deployed during construction. Fundamentally, the mapping of different materials should be closely linked. The recording should also include, for example, damages to surfaces through the environment or frost, such as abrasion, flaking, scaling, etc. But they should also include damages to the stone structure such as humidity as well any indications of previous coun-



*Mapping damages to the Regiswindiskirche, Lauffen am Neckar (streberwerk. Architekten GmbH, Stuttgart).*

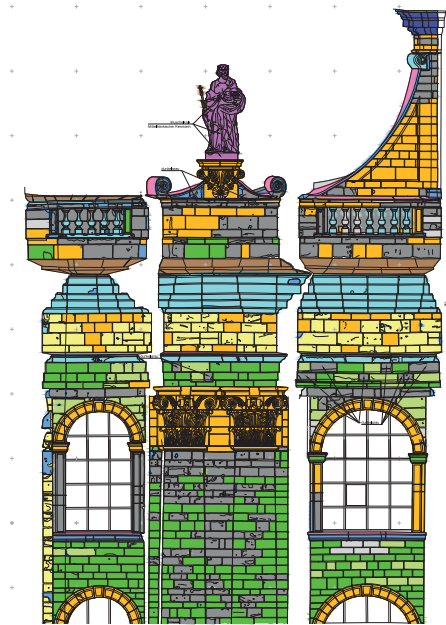

*The Basilica of Weingarten, mapping of stone materials (streberwerk. Architekten GmbH, Stuttgart), based on the plan drawings of Fischer Engineering Firm for Photogrammetry and Survey).*

termeasures (such as chemical moisture proofing). Ideally, the maps will be drawn by experienced specialists who are also able to suggest measures for repairing the damages and securing the preservation of the historical structures in separate sets of plan drawings.

Characteristic features drawn onto the map can be entered onto the line drawings created by the measured survey. These can be indicated by various colors

or hatchings which symbolize particular phenomena and which are explained in an accompanying legend. The markings can be entered manually onto printed plans or digitally with the help of special mapping software onto the CAD-plans.

Including all of the studies carried out within its framework, the building survey can result in a construction phase plan, which indicates the chronological sequence of the individual construction elements of the building and allows for conclusions on the development of construction and organization of a property. If the investigation of the structure has yielded good evidence for multiple building phases, each phase is assigned an

individual color and the corresponding building elements are marked accordingly on the plan drawing. The colors should be chosen from dark to light, with darker colors indicating older construction, lighter colors more recent work. The color scale should be explained in a separate legend. The phases can also encompass particular periods or ranges of time during which work was carried out, provided that these can be identified as distinct and coherent periods. The phases can also, however, indicate a relative chronology which shows that a particular element originated before or after another, without necessarily assigning a particular time-span to either.

*Vertical section of the "Unterer Yngramhof" in Mazon (South Tyrol), including indication of the construction phases. The original core of the building (blue) is clearly recognizable from the colored marking.*

- ca 1500
- 1642
- 1700-1800
- 19th century
- 2011



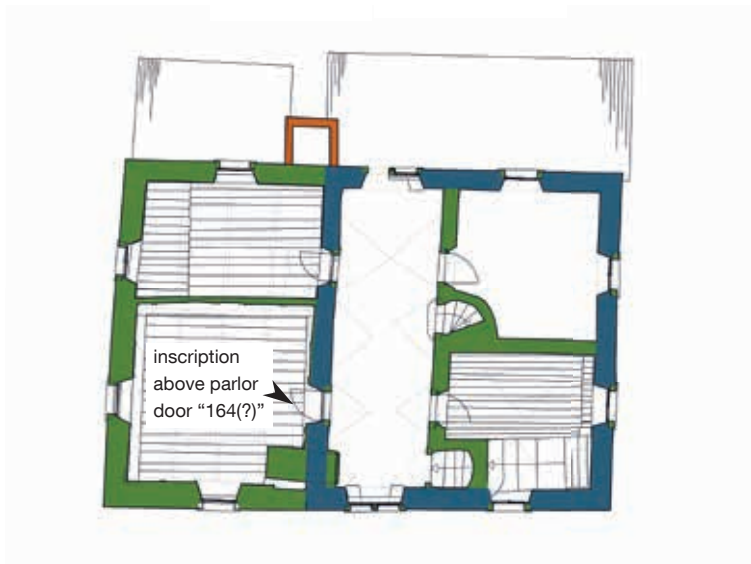

*Floor plans (ground floor, 2nd floor, 3rd floor) of the "Unterer Yngamhof" in Mazon (South Tyrol) with colored marking of construction phases.*

- ca. 1500
- 1642
- 1700-1800
- 19th century
- 2011





*Timber joinery and carpenter's marks in the roofing of the Liebfrauenmünster, Ingolstadt.*

## 5. Methods of Dating

Buildings or parts of buildings can be dated by various means. Evidence for dating can be found in the form of inscriptions on the building itself, in archives or building registries, or through conclusions drawn from decorative elements which can be linked to a particular period or style. Finds such as coins or dates found in newspapers can contribute evidence to support dating as well. Furthermore, the natural sciences provide two commonly used methods of determining the age of a building: dendrochronology and radiocarbon dating. Within a building, a relative chronology can be established for the relationship of individual building parts to one another, as is the case, for example, when construction seams suggest a secondary alteration or addition. These methods of dating will be presented briefly below.

Building inscriptions can be used to date buildings, parts of buildings, or interior furnishings. In timber frame constructions, inscriptions are often to be found in prominent corner posts, in masonry constructions, they are often engraved into the lintels of windows or doors. Dates are often found painted onto surfaces as well. These can contain the date of construction or renovation, the initials of the owner who commissioned the construction, or other names. Inscriptions need to be examined closely and critically, since they can also indicate later building sections or renovations.

The Ymgramhof contains two inscriptions, which record the dates: "1642" on the door lintel of the entranceway facing the street, and "164(?)" above the door of the parlor on the second floor.

Historical sources include published texts or illustrations and unpublished archival documents. These can provide pictorial evidence for determining the age of a building if the archival documents contain plans, drawings, or photographs which associate a particular condition of the building with a particular date. Invoices, house books, building descriptions, or

travelogs also often contain data on the dates of construction or of alterations. For more recent periods, cadastral maps and official construction files can also be a good source for dating.

Datable finds were already discussed in ► Chap. F.2. They can be mentioned here again briefly as a source for dating. Particularly in less frequently used rooms such as basements or attics or in blind floors, explicitly dated finds such as coins, documents, and newspapers or indirectly datable finds, consisting of objects typical of a particular period such as clothing, jewelry, or household objects, can be preserved for a long period of time. Newspapers or other waste-paper were often used to level the foundation surface of walls in preparation for more valuable wallpaper. These remnants of waste paper can also help at least to determine the age of the respective renovation or room decoration.

Thanks to particular buildings forms, ornaments, or forms of decoration, the period of construction can often be narrowed down solely based on art historical or stylistic considerations. This method includes, for example, the size and form of windows, the design of walls or ceilings with paintings, molding, or paneling, as well as ovens and heating elements, to name only a few.

For example, art historical considerations could be applied to the windows of the Yngramhof, which contains a biforate window on the second floor, and windows on the third floor with wooden frames and casements which show a graceful, professionally joined profiling typical of the Baroque Period. The specific manufacture of the glass planes and the way in which these are joined both also usually reflect particular characteristics which can be connected to a specific period. Fixtures installed into the walls such as decorative paneling in the living rooms of the second and third stories of the building indicate a particular phase of furnishings.

*Drill core sample from the “Unterer Yngamhof” used for dating the age of the timber (from top to bottom: transport tube, drill bit, core sample).*



The scientific methods of dating follow two separate paths. In the first, the precise measurement of the width of the individual year rings of wood samples can indicate the growth periods of the tree. In the second, the analysis of the rate of decay of the carbon isotope  $^{14}\text{C}$  can be used to determine the time which has passed since the end of biological growth.

Dendrochronological dating requires a sample to be taken from the object with a core drill. This sample has to fulfill particular requirements with respect to length, location of the sample, and means of sampling. The samples can be taken on site by the surveyor. Ideal targets are thick timber beams such as flexible foundation beams, roof beams, tie beams in vaulting, and posts from timber frame or roof constructions. Core drills can be found with various diameters of the bit, ranging from 2 cm to 5 mm. From the viewpoint of architectural history, thinner samples are generally preferred, since they cause less damage to the area. However, both thin drills and those cores which measure only a few millimeters are more delicate than the thicker ones. It is important to maintain a radial position when drilling in order to keep the sample of growth

rings as straight as possible. When more growth rings are included in the sample, the resulting dating will also be more secure. The date when the timber was felled can only be determined if the sample also includes the outermost ring or bark of the tree, the so-called wane. The sample can be analyzed by specialized firms, who grind and polish the sample and precisely measure the growth rings from the summer and winter growth phases with the aid of a microscope. The resulting measurements are transferred into a graph, which is then cross-matched with the values of the standard curve established for the last centuries. Standard curves have been established by a long-lasting series of studies for every common type of wood used in construction and have been verified by cross-reference to datings provided by historical sources. Since the curves differ from region to region, the samples should ideally be analyzed close to the property surveyed. The growth period of the tree can be identified by matching the sample with the standard curves. The age can ideally be determined to within an accuracy of a half-year period of growth. It should be noted, however, that timber is not necessarily used immediately for construction and may have been used for the construc-

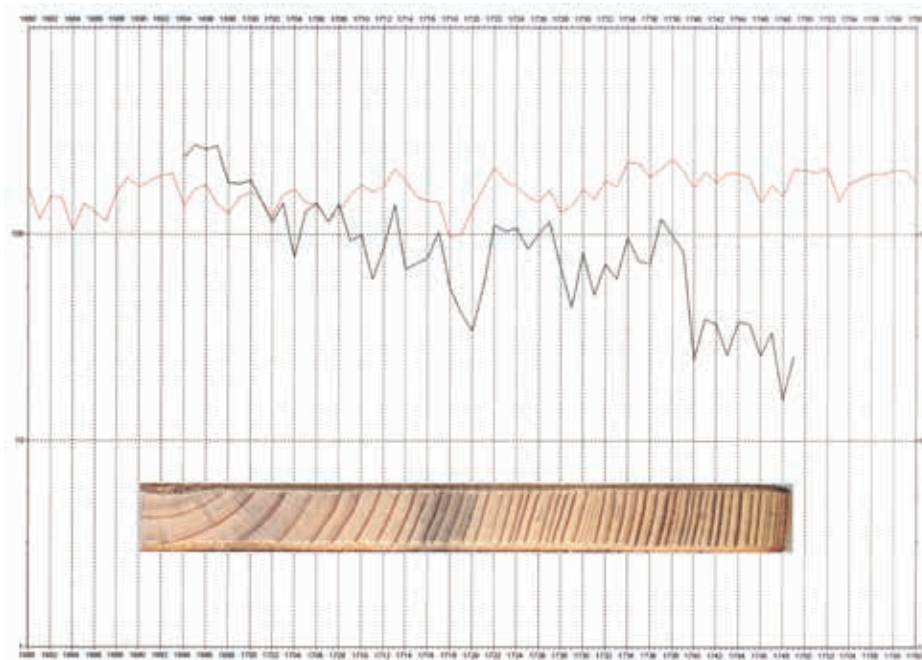

*Dendrochronological analysis by comparison of the standard curve (red) with the individual curve of the sample (black).*

tion secondarily. Seven wooden construction elements were sampled to determine the construction phases of the Yngrahamhof, of which only a small portion could be analyzed. The most salient date was derived from the tie beams of the ground floor, which yielded a date after the year 1491.

Radiocarbon Dating, first developed in 1946 by Willard Frank Libby, involves determining the age of carbon-containing, organic material by measuring the loss of  $^{14}\text{C}$  carbon atoms according to the standard rate of decay. Samples can be taken from all organic materials from the building under investigation: wood, plant fibers, construction materials derived from animals, etc. In living organisms, the special carbon isotope is constantly replenished by the supply of carbon from the environment. Its percentage thus remains constant until the death of the organism, when it begins to decrease. Since the specific half-life of atomic decay is known, special laboratories make use of an accelerator mass spectrometer to measure the remaining amount of  $^{14}\text{C}$  atoms and thus to determine the time which has passed since the organism's demise. The range of time which can be determined with radiocarbon dating is between 300 and 60,000

years. The resulting date is accurate to within several decades. Care should be taken that the sample is not contaminated with modern intrusions, such as woodbor-ing beetles.

In addition to these absolute dating methods, the building survey also makes use of relative chronology established by the relationship of the parts of the construction to one another. This was already discussed above in ► Chap. F.2 in the context of the analysis of features. Building features such as joints or seams, alterations, replacements, or additions of doors or windows can provide chronological evidence for the biography of the building based on their material or their established context. The context of the features plays a particularly important role here. As clearly shown in the image on ► p. 81 (above), the course of features may run behind walls which were added only later, while the more recent layers deviate from their course due to the newly formed corner. Based on the two different construction phases, it is possible on the one hand to determine the condition of the building before the later wall was added and, on the other hand, to narrow down the point of time when the alterations were made with respect to the overall building.



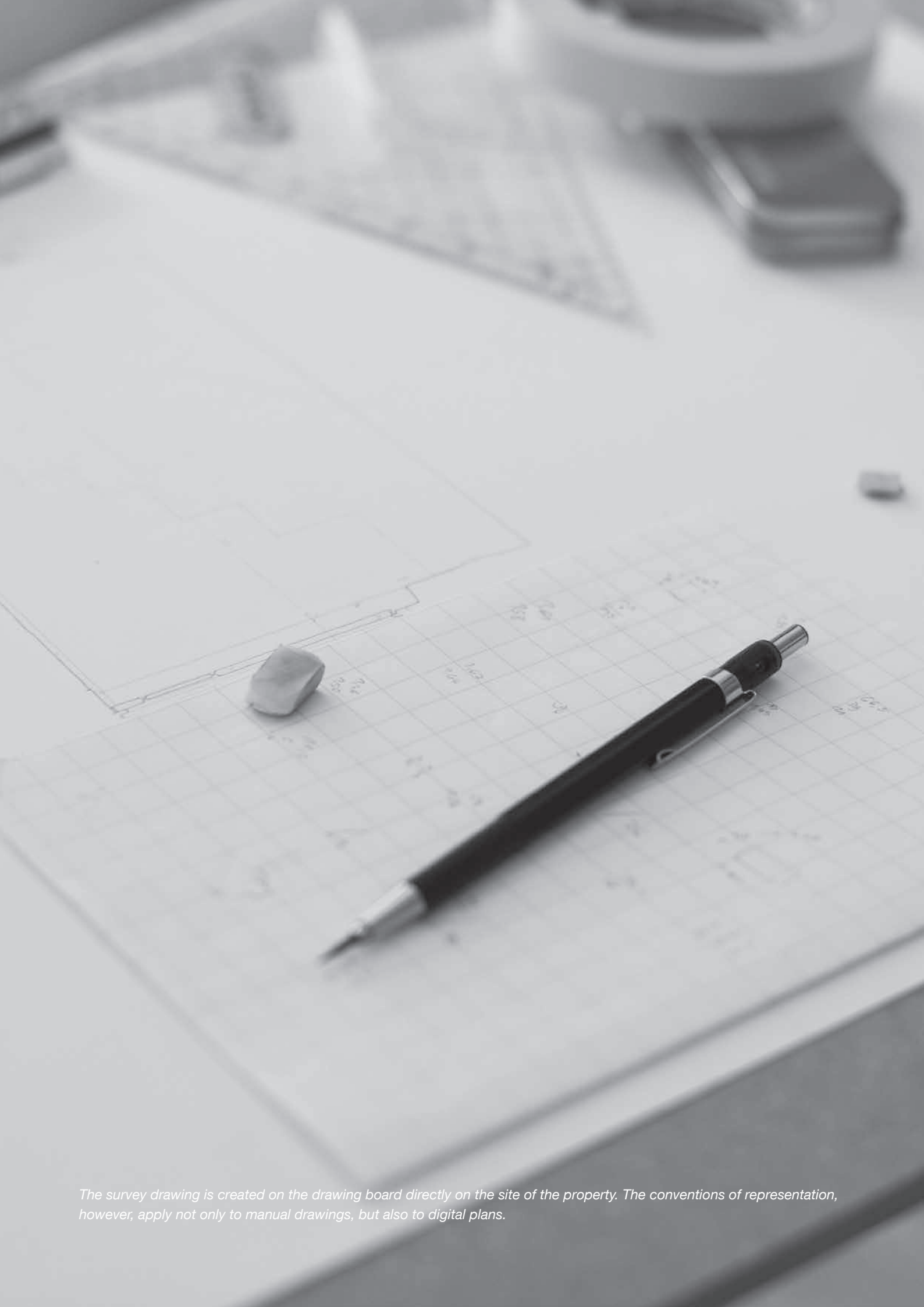

*The survey drawing is created on the drawing board directly on the site of the property. The conventions of representation, however, apply not only to manual drawings, but also to digital plans.*

## Appendix

### 1. Presentation

#### Drawing Conventions:

#### Types and Weight of Lines

Common standards and drawing conventions have been established in order to make drawings more legible. These prescribe the association of particular types and weights of lines with information on the content of the property depicted. Conventions for drawing do not deviate between plans of existing structures and those of new constructions, nor do they vary with regard to manual or CAD-assisted drawings. Anyone viewing a floor plan can thus recognize based on the lines used whether the object is contained within the measuring plane, that is, intersected, or whether it is located beneath it and thus viewed from above or depicted from a bottom view. Sections or views are associated with corresponding conventions.

Four combinations of types and weights of lines can be introduced here as obligatory drawing conventions:



Walls, supports, chimneys, and cabinets which reach the height of the ceiling, for example, are recorded as horizontal sections and thus drawn with a thicker, continuous line. Floors, steps, and similar features are recorded from a top view, and though they are also drawn with a continu-

ous line, the line should be noticeably thinner. In the section drawing, walls recorded as horizontal sections are drawn with lines thicker than those used to represent edge views or architectural features. When the section cuts through a wall with a door or windows, the wall and the intersected parts of the frame are drawn with a thicker line, while the course of the frame's profile is depicted as an edge view with a thinner line.

Projections of the objects above or behind the measuring plane, for example windows of greater height, ceiling joists, or vaulting, are depicted separately with thinner, broken lines. Broken lines are also used to depict the presumed courses of an object which have not been confirmed by measurement. Examples include seams or joints between parts of the building or areas inaccessible for measurement. Edges concealed by objects located either above or in front of them, such as the recesses of stairs, are entered into the drawing using broken lines.

If a traditional, manual survey recording is available, fine lines of alternating dots and dashes are used to indicate the plan of the measuring system. Both axes of string lines and laser levels in the main measuring grid and in any secondary measuring

#### Line types and weights

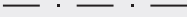
<i>Line</i>	<i>Type and Weight</i>	<i>Use/Meaning</i>
	thick, continuous	cut edges
	fine, continuous	side or top-viewed edges
	fine, broken	projections, bottom views, concealed edges
	fine, dot-and-dash	measuring system

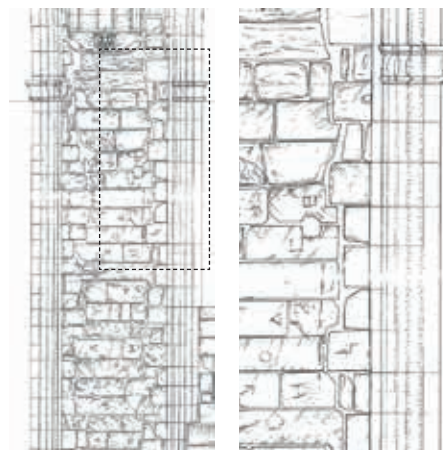
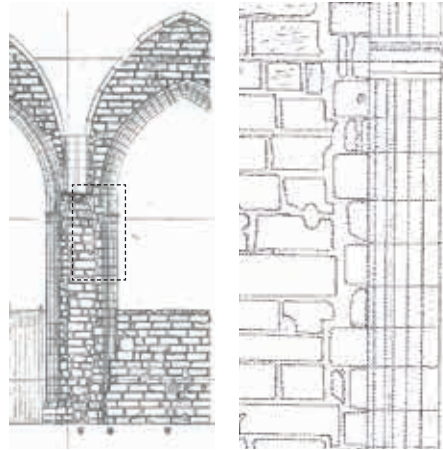

*Comparison of accuracy of representation:*

*Left are the reduced original plans (top: 1:50, bottom: 1:20), right the corresponding enlarged details with different levels of accuracy.*

grid are to be indicated on the drawing with very fine dot-and-dash lines using a hard pencil.

#### Levels of Accuracy

Several federal states in Germany and Austria mandate various levels of accuracy for a measured building survey. They prescribe the level of accuracy to be maintained in both measurement and depiction, which serves as a point of comparison for work estimates, particularly with respect to the calculated time required for the work. They thus represent the minimal standards to be maintained when carrying out a measured survey. These so-called levels of accuracy should thus be observed separately with respect to the specifications for accuracy in measurement and for accuracy in representation.

#### Accuracy of Measurement and Representation

Accuracy of measurement depends on various factors, including the method of measurement used, the (independent) measuring grid established to relate parts of the construction to one another, and the attention devoted to carrying out the work. During a traditional, manual building survey using a string measuring grid, the accuracy of measurement can be calibrated during measurement by checking the degree to which measured values are rounded up or down (precisely, 0.5 cm steps for a scale of 1:10, full centimeter values for a scale of 1:50, ...). The accuracy of measurement of a building survey carried out by using a tachymeter is usually greater than required for a depiction, since the values are always recorded up to the millimeter. Here, the person in charge of the measurement should have enough experience to decide what should be measured and how, keeping the goal of the measured survey in mind.

The accuracy of the representation is oriented towards the scale of the final plan or of the illustration as well as towards the most expedient degree of accuracy of the drawing, depending on the method used. Manual drawings on site usually conform

to an accuracy of about one half of a millimeter variance. Plans drawn on a larger scale, for example 1:10 or 1:20/25, can still include all relevant details. The smaller scales of 1:50 and 1:100, often preferred by architectural firms when subsequent processing is intended, demand a selection of which details are to be included so that the plan accurately represents the characteristic features of the building without overburdening the resulting drawing. Nevertheless, the care should be taken to maintain a standard of exact drawing and provide as much detail as possible even when using smaller scales. The more precise the drawing, the less information needs to be excluded. The decrease in accuracy in the representation remains problematic when using CAD-drawings, since these are usually visualized on the computer, in contrast to manual drawings on paper, which are drawn in the scale intended for the visualization. They thus quickly give an impression of being overly clumsy and lacking sufficient detail. At the same time, there also remains the danger of striving for too much detail, which can quickly overload the expression of information at the intended scale.

To summarize briefly, the established levels of accuracy can be characterized as follows (following Eckstein 2003, 11–13):

- **Level I:** Schematic representation without attention to damages to or deformations in the building (intended scale 1:100). The following information should be entered onto the plan: position and size of any openings in the wall, height of the floor ceilings and roof, thickness of the walls and ceilings; room geometry and angles are correctly represented through measurement of diagonals, simplified illustration of lattices, frames, or other constructions. The goal is the correct representation of a building type with an accurate outline of the floor plan, height gradation, and appearance as a first record of a building for planning a project or further measures without alterations in the structural fabric.
- **Level II:** Approximately faithful measurement (intended scale 1:50 or 1:100). The following information should be entered onto the plan: structural composition following correct proportions, including significant deformations; the representation of finishings and decorative details can be simplified according to their relevance; any indications of earlier structural conditions. Damages to the building and information on construction materials can be recorded as needed.
- **Level III:** Deformation-true measured survey (intended scale 1:50). In addition to the information listed under Level II, the following should be entered onto the plan: construction and structure of all parts of the building, including significant characteristics of surfaces, seams or joints, craftsmen's marks, representation of obscured areas of timber joints, indications of earlier structural conditions. Damages to the building, descriptions of construction materials of the construction itself, etc. can be added to the record as needed. Goal: exact drawing of the property with regard to any and all deformations with the aid of a system of three-dimensional measurement. This level of accuracy allows for the study of architectural history and provides the basis for any alterations on the building.
- **Level IV:** Deformation-true measured survey with detailed representation (intended scale 1:25 or greater). In addition to the information listed under Level III, the following should be entered onto the plan: highly detailed depiction of all structural and decorative details, for example by using double lines for stone masonry and timber frame joints as well as a depiction of all findings relevant to the history of the construction, including any remaining elements of earlier structures or their traces on the property. Goal: highly exact measured survey with high attention to detail and including any and all deformations, used as a basis both for difficult restoration or renovation work and for the scientific analysis of complex buildings.

Application of the Levels of Accuracy in Practice

The formulation of mandatory levels of accuracy in recording is designed to guarantee that results from the practice of building conservation by different persons and on different properties be comparable. The levels are irrelevant for scientific research. Advertisements for contracts which include a specific level of accuracy also allow the client to define the goal and, to some extent, the parameters of the expected costs and time involved. From the viewpoint of the practical experience of architectural firms, the levels are also associated with advantages as well as disadvantages. In principle, they prescribe only minimal requirements which need to be assigned and fulfilled. Private and public commissions are naturally always concerned with saving costs and will as a rule try to keep the associated outlay to a minimum, while the preservation of historic buildings usually gives preference to a recording of greater details. Compromised solutions often result in a lower level of accuracy than would be desired, particularly in documenting buildings of seemingly lesser value such as residential buildings or farmhouses. At present, the definitions of the levels of accuracy are in the process of being revised, particularly with regard to the large advances in technologically supported measurement and illustration.

Accuracy of Representation: Scales, Details, and Tolerances in Measuring

Drawings of measured surveys are usually made at a scale of 1:20 or 1:25 or 1:50. The choice of scale depends on the size and complexity of the building property to be surveyed as well as on the desired accuracy of details. The chosen scale can vary within a given project. In some cases, for example in large properties with complex room structures, it makes sense to illustrate the entire property at a scale of 1:50 or 1:100 in order to represent the dimensions and geometric relationships, but to illustrate selected parts of particular importance at a scale of 1:20 or as a detail drawing. The degree of detail and thus the

density of illustrated finds and information varies heavily depending on the chosen scale:

The scale of 1:20/25 is usually applied to smaller properties with a greater density of finds or to properties of exceptional architectural value. The scale of 1:10 is only used for special jobs (for example, portals or particularly important small buildings). This scale is also suited to supplement recordings drawn at a smaller scale with illustrations of patterned surfaces, wall sections, or special architectural details.

The representation should remain true to the masonry and to any deformations, that is, it should depict all individual elements of timber or stone constructions in their correct position and current condition, including all deformations, misalignments, and damages. Seams and joints are indicated as double lines with respect to the actual width of the seam. The surface structures of any materials are portrayed together with any features of the material and damages, while features such as mason's marks, assembly marks, or traces of tools are entered onto the drawing at their exact position. Windows and doors are measured and drawn including all profiling in the panes and frame.

Features related to the building's history, such as joints or later additions, are indicated and described in a brief text.

The scale of 1:50 is particularly suited to plans of larger properties or more complex structures, for example larger roof constructions or floor plans with numerous rooms. The drawings are detailed enough to depict the importance of the building for architectural history, but also take up less room than drawings at a scale of 1:20/25. The illustration remains true to the individual masonry and to any deformations in the construction, but is less detailed. Thus, the contours of any wooden elements or stones include only significant damages or deformations with an idealized representation of the gaps, which can, depending on the property, also be reduced to a single line. Windows and doors distinguish between movable panes

and frames. Features are usually marked as a circled number, which is explained in a legend at the edge of the sheet.

The scale of 1:100 is used for overviews. Walls and building structures are illustrated in their correct dimensions as double lines, larger deformations in the course of a wall are entered onto the drawing, and the room complex depicted with its actual geometry, that is, by taking the actual angles between parts of the construction or any misalignments and offsets into account. Overview drawings are usually supplemented by plans of individual parts of the building made in greater detail, so that together these plans form a meaningful set. Windows and doors can be indicated with symbols, but examples should at least be depicted in sufficient detail on a separate drawing if these have any value for the history of the building.

In addition, some plans are also drawn at a very large or very small scale. Detailed drawings up to a scale of up to 1:1 can form part of the building survey if particularly important features are present. These features can consist, for example, of particularly old windows or decorative elements, but also of details crucial for an

understanding of the techniques used in construction. Site plans at smaller scales, for example M 1:1000 to M 1:10,000, are usually only added to the survey portfolio as supplementary materials and do not form part of the main results of the actual survey.

The scale of drawing also determines the acceptable degree of accuracy tolerated during measurement. Drawings at a scale of 1:20/25 round off the measured values to the half-centimeter or centimeter. The scale of 1:50 allows for a tolerance of 2 cm, while the scale of 1:100 permits a tolerance of 5 cm.

Plan Layout: Heading, Labeling, Indicating Dimensions, North Arrow, Scale Bar

Labels on drawings should generally be kept to a minimum. The main means of communicating information from a measured survey is the accurate plan drawing. If absolutely necessary, for example for orienting finds, indicating heights, measurement values, or the dimensions of timber, the label should be written in clear, legible script in block letters as small as possible. Finds can either be entered directly onto the drawing or indicated with numbers on the drawing which are then explained in the margins, depending on

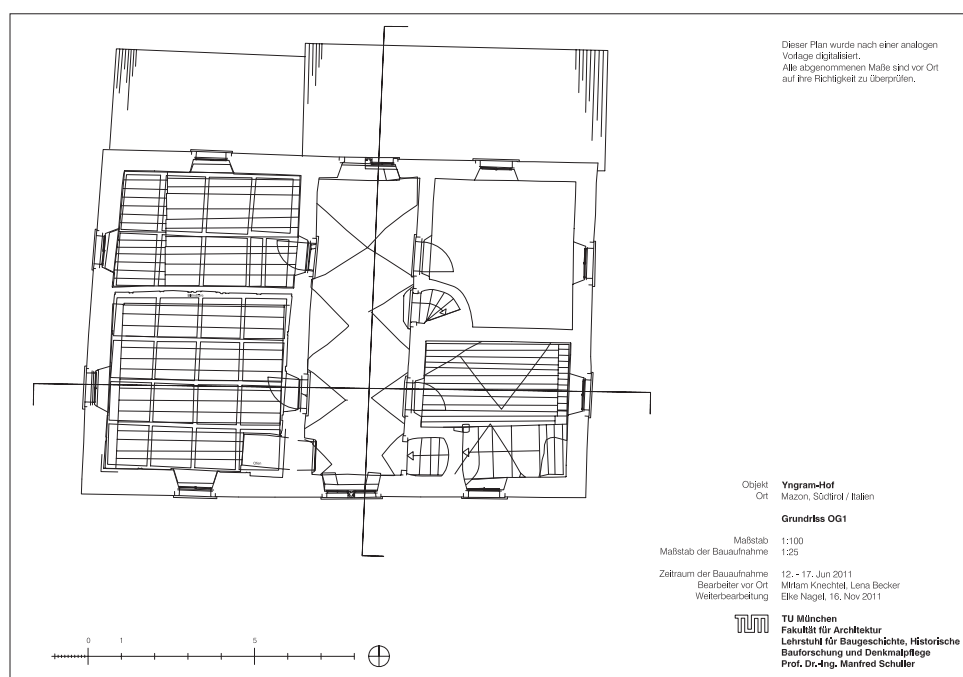

*Example of the layout of a plan, including scale, north arrow, and heading.*

the number of details contained in the plan and on the amount of space available on the drawing.

Dimensions are recorded exclusively in the form of the measurement values, either on extremely thin lines or small arrows which indicate the direction of measurement, not as chains of values listed in the margins.

Heights (elevations) are indicated by small triangles together with the relevant value. For this purpose, a zero-point is established on the property which serves as a relative benchmark for all further measurements of height.

If possible, this relative zero-point can also be referenced to absolute height above sea level, determined, for example, with the aid of nearby fixed points of the mapping survey of the respective region.

The location of section lines should be indicated on the floor plan. Any plan symbols or notation used which are not self-explanatory based on standard practices of architectural drawing, such as hatching for particular materials, should be explained on the sheet in a legend.

The heading of the drawing should contain all information important for the identification of the property, the method used in recording, and the illustration. This includes the following:

- on the property: name, location, address
- on the building survey: author, date, method of survey (manual, tachymetric, etc.)
- on the plan drawing: type of plan (section, floor plan, view), indicating the position within the building complex (ground floor, upper floor, section with view towards...) and compass direction (possibly including a north arrow)
- on the scale: numerical indication of scale and graphic scale bar (black-and-white blocks or line with dividing marks)

A north arrow should be drawn clearly visible at the edge of the drawing as an arrow, cross, or other unambiguous symbol in order to permit orientation of the plan.

A scale bar put on paper before the beginning of a building survey is absolutely essential for manual drawings. Since paper can warp considerably in length and width due to the effects of humidity and changes in temperature, a scale bar divided into small sections should be drawn onto two separate edges of the plan. All measurements can be taken from these scale bars with the aid of a compass. If the lengths are taken with plastic or metal ruler with constant length, errors may arise due to the "working" surface of the drawing. It is thus advantageous to draw the scale bar at the scale in which the drawing is made.

#### Post-Processing of Drawings

Post-processing of drawings includes not only the revision of manually drawn building recordings to produce final, submitted plans, scanning, and digitalizing manual drawings, but also the addition of details to raw CAD-plans in order to create digital plans of the building survey or renderings of photographs corrected for distortion to create photogrammetric plans.

Building surveys are recorded as manual drawings on site to include the complete level of detail required. If necessary, repetitive elements can be drawn only once on site as a template and subsequently added to the drawing at the required points. Post-processing of manual drawings generally results in final drawings, transferred onto tracing paper or drawing film by hand with ink or pencil. Final plans usually do not indicate information on the measuring system or the measurement values of the building survey recorded on the original drawings.

If at all possible, the now obsolete practice of ink tracing should be avoided, as it is both time consuming and can itself become a source of errors which should not be underestimated.

Many pencil drawings can be turned into publishable plans through the use of suitable methods of scanning. If hand drawings are scanned, the resulting images should afterwards be processed with image manipulation software in order to remove spots or blemishes and to correct tonal

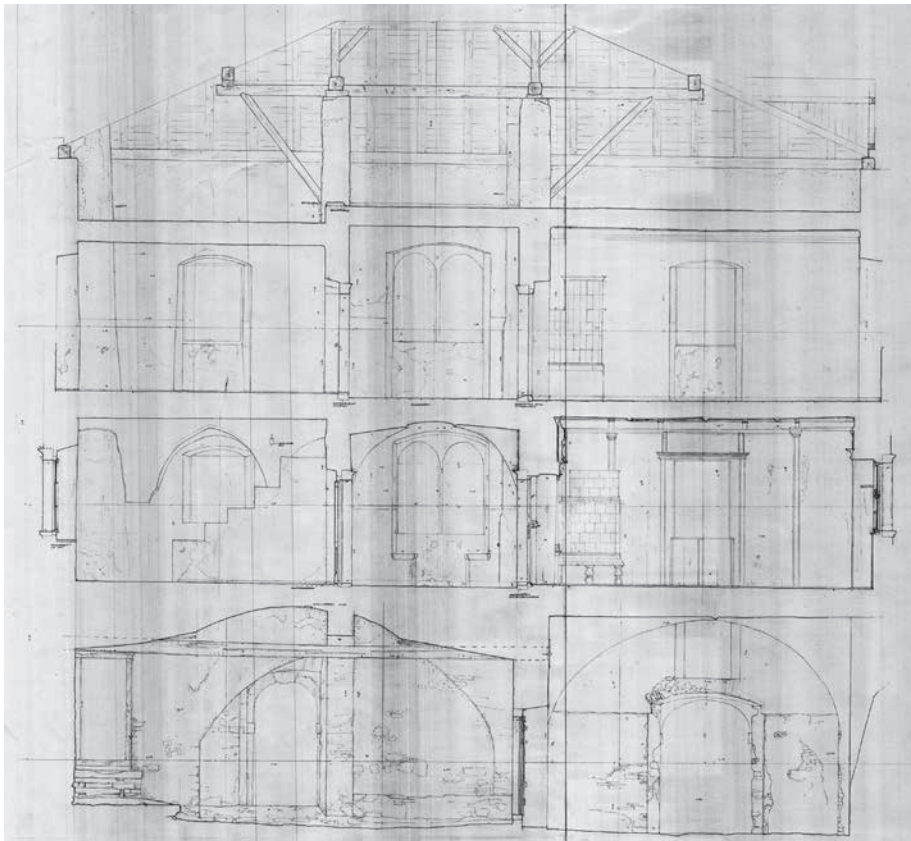

*Scan of a manual survey recording (pencil on cardboard).*



*Transformation of the manual drawing depicted above into a publishable original as a digital tracing.*



values and contrasts to be of publishable quality. The time invested in post-processing a scan from a manual drawing can be considerable, depending on the size of the original and accuracy of the processing!

An additional option for post-processing digital plans is provided by tracing scans in a CAD-program for vectorizing manual survey records. This method can be somewhat time-consuming, and may also lead to a significant number of errors. Particular care should be taken that the scale of the resulting plan is applicable to the level of detail required. CAD-programs can allow for a considerable zoom, which often leads to the temptation of pursuing a greater level of accuracy than the original may allow or than may be visible in the printed plan. It is usually necessary to transform the original into a vector drawing if the survey record is to be used by architects or other specialists as a basis for planning alterations or renovations.

If CAD-plans are already drawn on site during the building survey, the resulting raw data generally requires substantial post-processing. Common steps of post-processing include the intersection of lines to form building edges, processing corners, and straightening survey lines. The important goal is to depict all deformations of the measured building correctly without creating a false picture of deformations based on inaccuracies generated by the electronic instruments. Particularly when the scale of the final drawing will be at 1:50 or 1:100, lines of building elements should thus be straightened, sections of parts of the roofing should be simplified to

yield regular cut surfaces. A final detailing of windows, doors, or decorative elements is also usually required if these have been recorded on site with a manual drawing and were only subsequently added to the CAD-drawing during post-processing based on fixed points.

Since programs such as PhotoPlan were first introduced, which allow for the creation of single-image photogrammetries and distortion-corrected photographs, tracing corrected photographs has also become a common task. Particular attention should be given to the original so that the relational geometry of the property is rendered correctly. In particular, properties with several staggered floors require that the photographic distortion be corrected separately for every level (► Chap. E.2.). Though tracings of distortion-corrected photographs can provide a valuable basis for mapping, they by no means replace the measured survey. In each case, the methods used should be indicated on the plan drawing.

In general, attention should also be paid to archivability. Manual drawings should be made with a pencil on acid-free paper or cardboard. Suitable portfolios can be recommended for storage as well as for protection against light and humidity. Prints or copies are generally less suited for archivization, since the permanence of printer ink has so far not been confirmed empirically. If the work is to be archived digitally, care should also be taken to make use of sustainable storage media and to update the file formats used regularly to keep up with the newest standards.

## 2. Glossary

**Axis of Rotation :** Vertical axis of a survey instrument used to turn the ocular lens.

**C14 (Radiocarbon Dating):** Method of determining the age of wood by measuring the amount of  $^{14}\text{C}$  atoms in a material sample.

**Circular Bubble (or Spirit Level):** Tool used to control the horizontal position of other instruments.

**Control Point/Reference Point:** A fixed, clearly identifiable, and numbered point on a building used to position a measuring instrument or to control photographs for distortion.

**Dendrochronology:** Method of determining the age of wood based on the growth rings in comparison with a known reference curve.

**Distortion Correction:** Geometrical correct recalculation of a photograph based on reference values or points.

**Independent System:** ► Measurement Grid.

**Laser Level:** Device for the horizontal and vertical projection of laser lines onto surfaces to be measured.

**Leveling:** Determination of information on the height of desired points in relation to a predetermined zero-level.

**Measuring Plane:** Plane on a clearly defined height used as a basis for survey measurement.

**Measurement Grid:** Artificially established reference system with defined points or lines for deformation-true measurements.

**Measurement Points:** All measured points used for recording floor plans, views, and sections.

**Optical Lens:** Optical device which forms part of measuring instruments and is used to locate measurement points.

**Optical Level (or simply Level):** Instrument used to measure horizontal angles within the same plane; depending on the device used, distances and/or horizontal angles can be measured as well.

**Photogrammetry:** Method of gaining geometric information from photographic material.

**Single-Image Photogrammetry:**

A type of pseudo-photogrammetry which requires additional geometric information, with two-dimensional results.

**Stereophotogrammetry:** Determination of spatial information by comparison of identical points on two photographs, with three-dimensional results.

**Multi-Image Photogrammetry:** Determination of spatial information by correlation of identical points on multiple photographs. The results are three-dimensional and can also allow for the processing of complex geometries.

**Planation:** Projection of measurement points with x, y, and z-coordinates onto a defined plane. Planation allows for better processing than a 2D-drawing.

**Positioning:** Determination of the position of a measuring instrument at a particular viewpoint with reference to existing control or reference points.

**Rectified Mosaic:** A complete composite plan assembled from individual images corrected for distortion.

**Room Data Sheet:** System of distinctly designating rooms, walls, etc. within a building which includes a full documentation of all features and observations.

**Scale Bar:** Vertical and horizontal dimension lines added to the edge of a drawing, particularly manual drawings.

**Station Point:** Exact location point of the tachymeter. Each new location is calibrated and thus defined by precise x, y, and z coordinates.

**String Grid:** System of intersecting horizontal and vertical strings used in the measurement of historic buildings by means of a manual recording.

**Swivel Method:** Approach to determining the shortest distance from a point to a measuring line by using a folding rule.

**Tachymeter:** Instrument for measuring horizontal and vertical angles as well as the absolute distance between the station point location and a measurement point. Points can thus be located precisely in space.

**Theodolite:** Instrument for measuring horizontal and vertical angles.

**Tilt Axis:** The horizontal axis of a survey instrument used to tilt the ocular lens.

**Total Station:** Combination tachymeter and laptop/computer. Measured data can be processed immediately and displayed on the screen.

**Triangulation:** Means of control in transferring a measuring grid to a plan drawing.

**Tripod Head:** Upper surface of a tripod with a mounting plate for measuring instruments.

**UCS (User Coordinate System):** The coordinate system defined by the user in CAD-software.

### 3. List of Illustrations

Page 8: Letarouilly, Paul: *Edifices de Rome moderne*, Paris 1840

Page 10: Viollet-le-Duc, Eugène: *Dictionnaire raisonné de l'architecture Française du XI° au XVI° siecle*, Paris 1854–68

Page 11: Österreichischer Ingenieur- und Architektenverein: *Das Bauernhaus in Österreich-Ungarn*, Wien 1906

Page 80 top, 84, 89: strebewerk. Architekten GmbH, Stuttgart.

All other illustrations belong to the Chair of Building History, Building Archaeology, and Conservation, Technical University Munich.

## 4. Bibliography (selective, since 1990)

**Bedal**, Konrad: *Historische Hausforschung*, Bad Windsheim 1995.

**Breitling**, Stefan; **Giese**, Jürgen (Hrsg.): *Bauforschung in der Denkmalpflege. Qualitätsstandards und Wissensdistribution*, Bamberg 2018.

**Bruschke**, Andreas (Hrsg.): *Bauaufnahme in der Denkmalpflege*, Stuttgart 2005.

**Cramer**, Johannes: *Bauforschung – eine kritische Revision. Historische Bauforschung zwischen Marketing und öffentlichem Abseits*, Berlin 2005.

**Donath**, Dirk: *Bauaufnahme und Planung im Bestand*, Wiesbaden 2008.

**Eckstein**, Günter: *Empfehlungen für Baudokumentationen, Bauaufnahme, Bauuntersuchung*, Stuttgart 2003.

**Grossmann**, G. Ulrich: *Einführung in die historische und kunsthistorische Bauforschung*, Darmstadt 2010.

**Hassler**, Uta (Hrsg.): *Bauforschung. Zur Rekonstruktion des Wissens*, Zürich 2010.

**Hubel**, Achim: *Ausbildung und Lehre in der Denkmalpflege. Ein Handbuch*, Petersberg 2001.

**Hubel**, Achim: *Denkmalpflege. Geschichte, Themen, Aufgaben. Eine Einführung*, Stuttgart 2006.

**Klein**, Ulrich: *Bauaufnahme und Dokumentation*, Stuttgart 2001.

**Mader**, Gerd Th.: *Angewandte Bauforschung*, Darmstadt 2005.

**Marino**, Luigi: *Il rilievo per il restauro*, Milano 1994<sup>4</sup>.

**Petzet**, Michael; **Mader**, Gerd Th.: *Praktische Denkmalpflege*, Stuttgart/Berlin/Köln 1993.

**Schuller**, Manfred: *Building Archaeology, ICOMOS Monuments and Sites*, München 2002.

**Weferling**, Ulrich (Hrsg.): *Von Handaufmaß bis High Tech. Messen, modellieren, darstellen. Aufnahmeverfahren in der historischen Bauforschung*, Mainz am Rhein 2001.

**Weferling**, Ulrich: *Bauaufnahme als Modellierungsaufgabe*, Deutsche Geodätische Kommission, Reihe C, Heft Nr. 561, München 2002.

