

# ProsNet – a Modelica library for prosumer-based heat networks: description and validation

I Elizarov, T Licklederer

Munich School of Engineering, Technical University of Munich, Lichtenbergstr. 4a,  
85748 Garching, Germany

E-mail: ilya.elizarov@yahoo.com

**Abstract.** Prosumer-based heat networks are a new concept in district heating systems that uses the ability of prosumers to operate as either producers or consumers. This type of networks allows for utilizing distributed heat generation and renewable energy sources. A broad range of individual operating modes, heat generation technologies, and topologies determine complex thermo-hydraulic behavior of such networks. Simulations help gain insights into their properties. In this paper, a Modelica library *ProsNet* is presented for such simulations. It is designed to set up models of prosumer-based heat networks to investigate their dynamic and steady-state performance in a user-friendly way. Important models of the library are described in more detail. Finally, a successful validation of the developed components was performed by comparing simulation results with another software for modeling bidirectional heat networks in steady-state.

## 1. Introduction

District heating could contribute to the decarbonization of energy production and improve supply security by integrating renewable sources, storage, and energy coupling between different sectors. These features are commonly found in the newer generation of district heating systems. Implementations of such systems also includes an ability for bidirectional energy flow [1]. This means that the participants, or in other words prosumers, can produce or consume heat with respect to the heat network depending on a current operating mode. Prosumer-based heat networks promote distributed heat generation including renewables. Furthermore, they exploit the synergy between users and increase flexibility of the heat supply. Potentially, customers in such network could shift a market paradigm from a production-centralized model to a decentralized one where substations can freely exchange energy for a price [1]. Considering the complexity mainly associated with operation strategy and pressure difference limitations [2], there is a need for a toolbox that can effortlessly simulate this type of network. This will allow users to focus on the thermohydraulic operation, investigating new control concepts and various types of generation that are compatible with these networks. The paper describes the Modelica library *ProsNet* that was developed for this purpose.

The underlying scheme of a prosumer is shown in figure 1. It is based on an actual experimental setup at the CoSES lab at the Technical University of Munich. The prosumer is in production mode when the net heat flow rate on the secondary side  $\dot{Q}_{\text{net}}$  [W] is positive and vice versa for consumption mode. The net heat flow rate, in turn, is formed by heat supply  $\dot{Q}_{\text{source}}$  [W] and demand  $\dot{Q}_{\text{sink}}$  [W]:

$$\dot{Q}_{\text{net}} = \dot{Q}_{\text{source}} - \dot{Q}_{\text{sink}} \text{ [W]} \quad (1)$$



The plate heat exchanger hydraulically separates the secondary side from the primary side. The primary side is connected to a two-pipe heat network. The direction of the flow in the network is defined by control elements on the primary side: a control valve and a feed-in pump in parallel. They are active depending on the operating mode: in production mode, the feed-in pump is active, and the control valve is closed, for the consumption mode, the feed-in pump is shut down, but the control valve maintains the flow. On the secondary side, the direction of the flow is established by a pair of circulation pumps operating in opposite directions: production and consumption pump. At least one customer must be in production mode to maintain a pressure difference in the network.

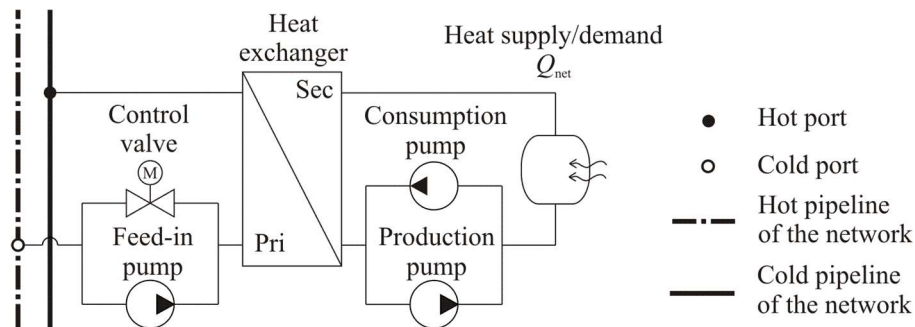

Figure 1. The underlying scheme of a prosumer.

## 2. Arrangement of the ProsNet library

The models in the library inherit components from the *IBPSA* library (version 3.0.0) and the *Modelica Standard Library* (version 3.2.3). Necessary components of the *IBPSA* library were copied to the library so it can be used with the default workspace available for every simulation environment. All fluid components are initialized with the incompressible water media model.

The overall structure of the library is given in figure 2. A prosumer model, as well as its base classes, are included in the *Prosumers* package. The *Controls* package contains control-related elements. The *Fluid* package consists of models for thermo-fluid flow. A liquid-to-liquid heat exchanger model (*LiquidToLiquid*), a control volume with prescribed outlet temperature independent of the flow direction (*ControlVolume\_T*), and a pipe model with thermal losses (*InsulatedPipe*) were developed for the library. Examples of prosumer-based heat networks are provided in the *Examples* package. Important models of the library are described below.

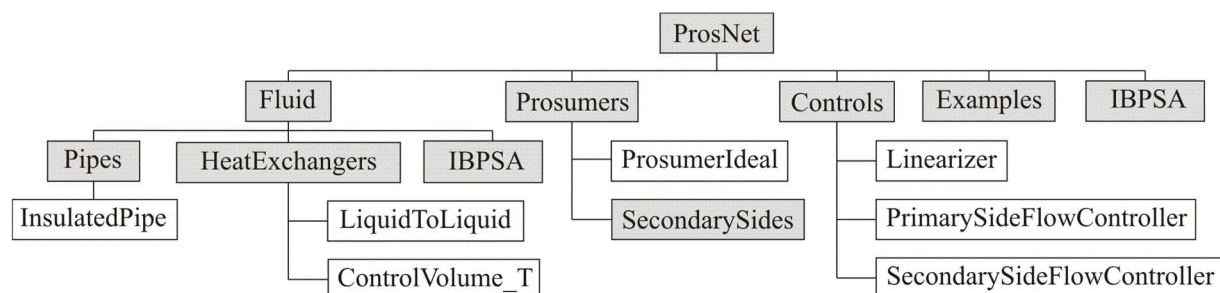

Figure 2. The overall structure of the ProsNet library.

### 2.1. Heat exchanger model

The *IBPSA* library does not contain a model or a function for calculating the overall heat transfer coefficient for liquid-to-liquid heat exchangers. This coefficient must be defined by the end-user. The *LiquidToLiquid* heat exchanger model extends from the *PartialEffectivenessNTU* partial model and provides the required value in *ProsNet*.

The derived expression for the overall heat transfer coefficient is based on the following assumptions. First, thermal resistance through the wall  $L/\lambda$  [(m<sup>2</sup>·°C)/W] is negligible compared to thermal resistance of convection on primary  $1/\alpha_1$  [(m<sup>2</sup>·°C)/W] and the secondary  $1/\alpha_2$  [(m<sup>2</sup>·°C)/W] side:

$$h = \frac{1}{\frac{1}{\alpha_1} + \frac{L}{\lambda} + \frac{1}{\alpha_2}} \approx \frac{1}{\frac{1}{\alpha_1} + \frac{1}{\alpha_2}} [W/(m^2 \cdot ^\circ C)] \quad (2)$$

Second, flow conditions predominantly determine the heat transfer for nominal and actual values of the convective coefficients:

$$\frac{\alpha}{\alpha_{\text{nom}}} = \frac{\text{Nu}}{\text{Nu}_{\text{nom}}} \sim \left( \frac{\dot{m}}{\dot{m}_{\text{nom}}} \right)^b \quad (3)$$

where  $\alpha$  is the actual convective heat transfer [W/(m<sup>2</sup>·°C)],  $\alpha_{\text{nom}}$  is the nominal heat transfer coefficient [W/(m<sup>2</sup>·°C)], Nu and Nu<sub>nom</sub> are the Nusselt numbers for actual and nominal conditions [-],  $\dot{m}$  and  $\dot{m}_{\text{nom}}$  are actual and nominal mass flow rates [kg/s].

Combining formulas (2) and (3), the actual overall heat transfer coefficient can be computed for any new value of mass flow rate other than the nominal one. The exponent  $b$  in formula (3) can be taken from an appropriate correlation for the Nusselt number for plate heat exchangers [3]:

$$\text{Nu} = A \cdot \text{Re}^b \text{Pr}^c [-] \quad (4)$$

where Re is the Reynolds number [-], Pr is the Prandtl number [-].

## 2.2. Flow controller

This model generates control signals for pumps and actuators depending on the operating mode and participation. The valve receives zero opening signal for production mode, while the production and feed-in pumps are active and vice versa for consumption mode.

## 2.3. Linearizer

When only a small pressure drop is allowed by a control valve, the most used valve type has an equal percentage inherent characteristic. The volumetric flow rate through such a valve can be expressed as:

$$\dot{V} = K_v \cdot f(op) \left( \frac{\Delta p}{SG} \right)^{1/2} [\text{m}^3/\text{h}] \quad (5)$$

where  $K_v$  is the flow factor [m<sup>3</sup>/(h·bar<sup>1/2</sup>)];  $f(op)$  is the inherent characteristic, which is a function of the opening [-],  $op$  is the opening of the valve [-],  $\Delta p$  is pressure drop at the valve [bar], and SG is the specific gravity of the fluid [-].

The inherent valve characteristic is non-linear. To linearize the flow rate with respect to the valve characteristic, the opening is substituted with its inverse:

$$op = f^{-1}(\kappa) \quad (6)$$

where  $\kappa$  is the actual flow coefficient, which varies between zero and one [-].

The flow coefficient  $\kappa$  serves as one of the inputs of the prosumer model. The function (6) is provided by the block *Linearizer* of the *ProsNet* library and is calculated as an inverse of the equal percentage valve characteristic from the *IBPSA* library.

## 2.4. Prosumer model

The prosumer model, shown in figure 3, is composed of primary and secondary side submodels. Seven inputs control the prosumer: operating mode  $\mu$ , participation  $\pi$ , the normalized velocity of the feed-in pump  $u$ , valve flow coefficient  $\kappa$ , mass flow rate on the secondary side  $\dot{m}_{\text{sec}}$ , and the outlet temperature of the heat supply/demand block  $T_{\text{sec}}$ . They can be individually set as parameters instead of accepting input signals.

The secondary side submodel represents technology-dependent heat generation and demand implementation. In the current release of the library, a prescribed outlet temperature control volume model (*PrescribedSecondarySide*) is available.

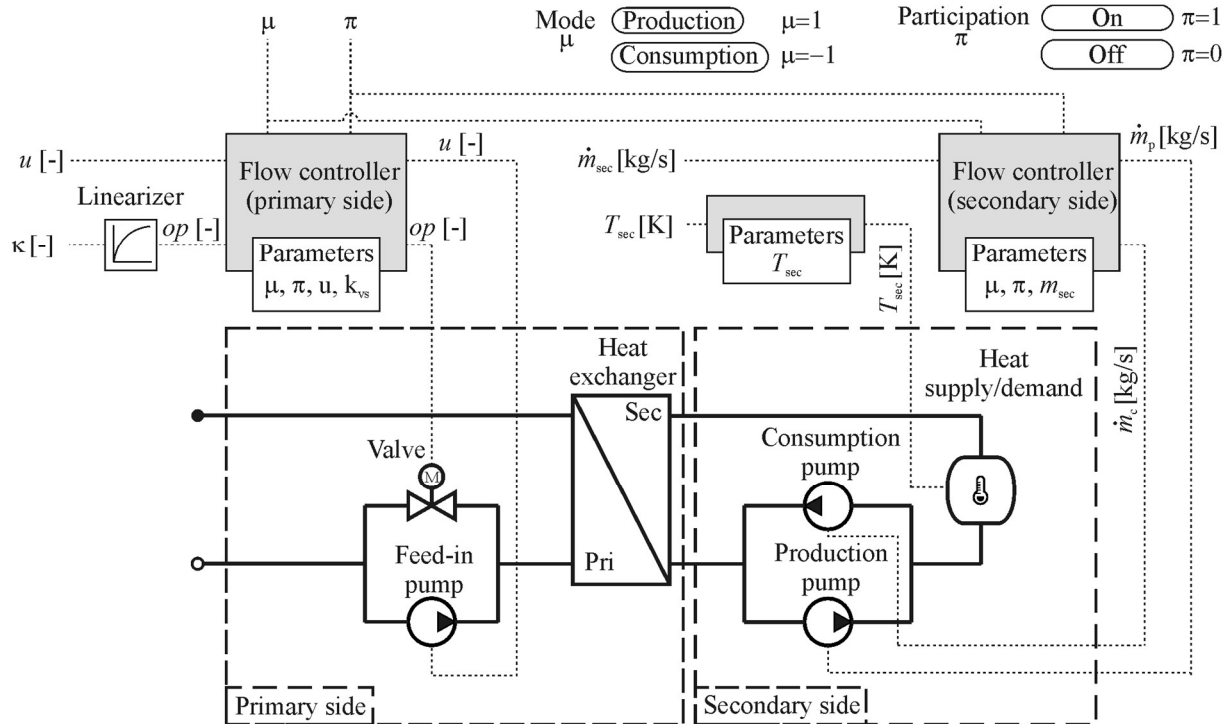

Figure 3. The prosumer model in the library.

### 3. Validation

To determine the accuracy of the developed models, validation was performed with the results acquired from the *ProHeatNet\_Sim*, a Python framework for simulating bidirectional heat networks [4]. In addition, the absolute and relative errors between the two were calculated. Three prosumer models were put together to form a radial heat network (see figure 4). A corresponding model for validation is provided in the library's *Examples* package.

The following essential parameters are set for components of the library and the framework. For the pipeline section, length is 10 m, diameter is 0.022 m, and local pressure loss factor  $\zeta$  is 3.5. For prosumers, the quadratic feed-in pump's performance curve has a shut-off head at  $402.21 \cdot 10^2$  Pa and a maximum flow rate of 55.33 l/min. The control valve's nominal flow coefficient  $K_v$  is 2.5 m<sup>3</sup>/h. The heat exchanger's nominal heat flow rate is 30 kW, inlet temperatures are 70 °C and 45 °C on the primary and secondary side, respectively. For both sides, nominal flow rates are 21.48 kg/min with a pressure loss of  $155 \cdot 10^2$  Pa. The ambient temperature for simulating thermal losses in the pipes is 12 °C, the thermal resistance of the insulation is 3.78 (K·m)/W.

To acquire comparative results from *ProsNet* and *ProHeatNet\_Sim*, two sets of operating modes are given in table 1. For both cases, the flow rate on the secondary side  $\dot{m}_{sec}$ , was kept 10 kg/min, and two values of the inlet temperatures on the secondary side  $T_{sec}$  were applied: 65 °C for production mode and 45 °C for consumption mode.

The *ProsNet* library can perform both dynamic and steady-state simulations, while *ProHeatNet\_Sim* is only capable of steady-state simulations. For this reason, the tested components were initialized in steady-state. There are minor differences in flow models of pipes and heat exchangers as well: the Darcy-Weisbach friction factor and the overall heat transfer coefficient in *ProHeatNet\_Sim* are defined for nominal conditions and kept constant. For this reason, some discrepancies between the results were expected.

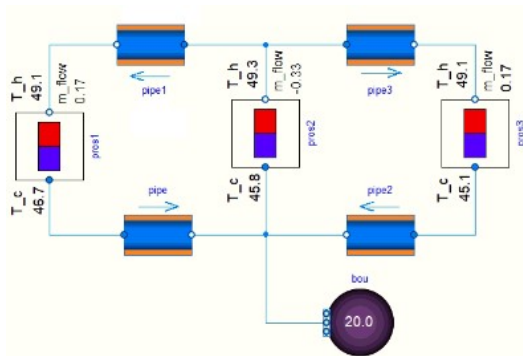
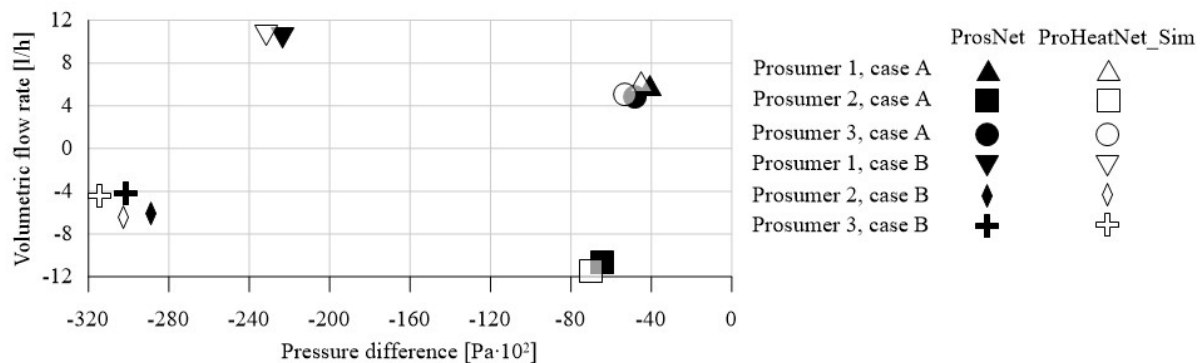

**Figure 4.** The prosumer-based heat network for validation.

**Table 1.** Operating modes and inputs for validation.

Case	Prosumer no.		
	1	2	3
A	Cons., $\kappa=0.9$	Prod., $u=0.6$	Cons., $\kappa=0.6$
B	Cons. $\kappa=0.6$	Prod., $u=0.9$	Prod. $u=0.9$

The compared pressure difference and flow rate for *ProsNet* and *ProHeatNet\_Sim* is shown in figure 5. The *ProHeatNet\_Sim* framework underestimates pressure losses due to the simplified flow model. The pressure difference at the connecting ports is lower for *ProsNet* because of the actual Darcy-Weisbach friction factor for hydraulic losses. For case A, maximum relative error for pressure difference between the models was found for prosumers 1 and 3: 11.7% and 11.6%, respectively. For case B, the relative error for prosumer 2 is 4.9%, and for prosumer 3 – 4.4%. Due to the quadratic law between the flow rate and pressure drop, the relative error for the volumetric flow rate is lower than for the pressure difference: 6.4%, 7.1% for prosumers 1, 3 in case A, for the same prosumers in case B: 3.2% and 3.7%.



**Figure 5.** The plot of flow rate and pressure difference at prosumers.

The heat flow rate through the heat exchanger of each prosumer is shown in figure 6. The flow rate through the heat exchanger for all the cases is significantly less than for the nominal value. A change in the flow conditions is not considered for *ProHeatNet\_Sim*, as a result, the heat flow is overestimated. On the contrary, *ProsNet* determines the change in the overall heat transfer coefficient. This, along with the decreased flow rates, explains lower thermal power for *ProsNet*. The calculated relative error between the results varies in the interval 10.4% - 9.9% for case A, and 9.45% - 8.16% for case B.

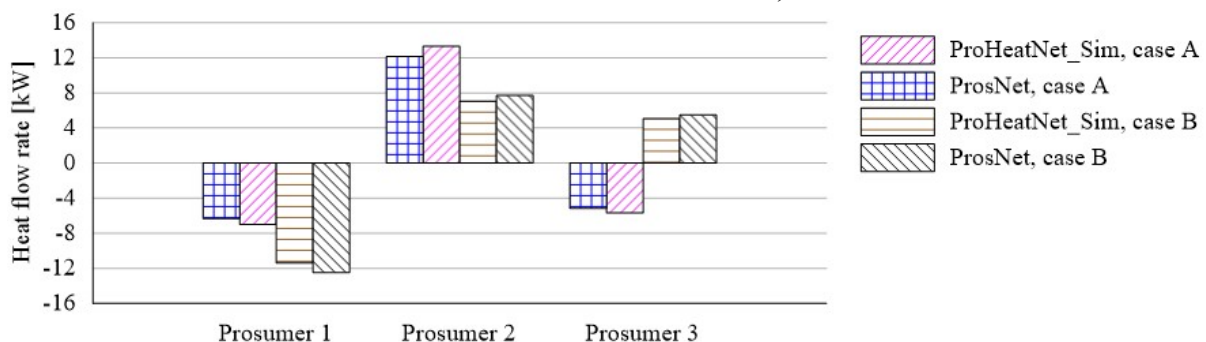

**Figure 6.** The plot of heat flow rate transferred to the network from prosumers.

The temperatures on the primary side of the prosumers are shown in figure 7. Note that due to the thermal losses in the pipelines, the temperature at the hot ports of the prosumers in consumption mode is lower than that for production mode. The error estimation showed that the maximum absolute error between the results for *ProsNet* and *ProHeatNet\_Sim* is 0.27 K and 0.65 K for prosumer 1 in case A and B for the cold port.

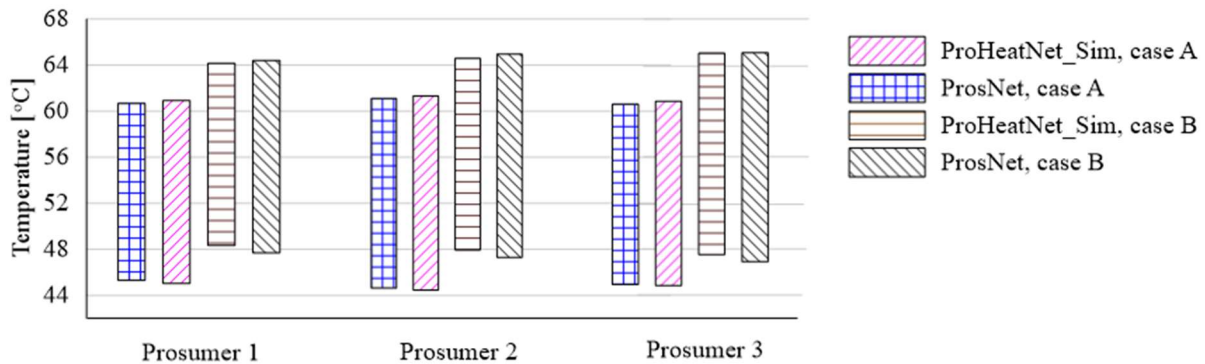

**Figure 7.** The plot of temperature at hot ports (top of the bars) and cold ports (bottom of the bars) at prosumers on the primary side.

#### 4. Conclusion

For the validation of the library, the results obtained from the *ProsNet* library and the *ProHeatNet\_Sim* framework were compared. Although the results demonstrated a certain discrepancy in the heat flow rate and pressure drop, the reasons for the differences were explained. In principle, the two approaches align and can predict the outcome of one another, but the distinctive features of both must be taken into consideration. The *ProsNet* library contains essential models to simulate prosumer-based heat networks. It allows for a dynamic and steady-state simulation of such networks in a user-friendly way. *ProsNet* is available at: <https://github.com/ilyaelizarov/ProsNet>.

#### References

- [1] Buffa S, Cozzini M, D'Antoni M, Baratieri M and Fedrizzi R 2019 *Renewable and Sustainable Energy Reviews* **104** 504-522
- [2] Elizarov I 2020 Master's thesis: Analysis, modelling, and control strategy development for prosumer-based heat networks DOI: 10.13140/RG.2.2.24851.71206
- [3] Yang J, Jacobi A and Liu W 2017 *Applied Thermal Engineering* **113** 1547-1557
- [4] Lickleder T, Hamacher T, Kramer M and Perić V 2021 *Energy* **230** article 120825