

# Multi-Sensor Fusion for a UAV/USV Tandem System for Spatial Data Collection of Waterways

Louis Makiello

Geodetic Institute and Chair for Computing in Civil Engineering & Geo Information Systems,  
RWTH Aachen University, Mies-van-der-Rohe-Straße 1, 52074 Aachen

E-Mails: Louis.Makiello@gia.rwth-aachen.de

**Abstract:** The aim of the RiverCloud research project is to develop an autonomous and networked unmanned tandem system consisting of an unmanned aerial vehicle (UAV) and an unmanned surface vehicle (USV) for the collection and provision of spatially and temporally high-resolution data for the development and maintenance of waterways and to support waterway management. The collected data will be analyzed by fusion with existing macroscale data and the results will be integrated into the models and workflows of users from the water management sector. An essential task to be solved for the practical use of the tandem system is the multi-sensor fusion for exact position and orientation estimation, especially of the USV, and for georeferencing of all collected data. For this purpose, data from GNSS, IMU and cameras are to be fused by means of dynamic state estimation. In this contribution the UAV/USV tandem system is presented. Particular attention is paid to the developed sensor fusion algorithm and the implementation using ROS.

*Keywords:* Multi-sensor fusion, visual odometry, ROS, UAV, USV

## 1 Introduction

### 1.1 Project overview

The RiverCloud research project brings together seven partner organisations to develop and evaluate a novel method of holistically monitoring inland water bodies as well as storing acquired data and making it available to stakeholders.

Data acquisition is to be carried out by two vehicles: a USV (unmanned surface vessel) and a UAV (unmanned aerial vehicle), operating either together (tandem mode) or alone. Four missions are to be undertaken:

- The first is carried out either by the USV alone or by the USV aided by the UAV. It consists of recording underwater topography using a multibeam echo sounder as well as flow velocity via ADCP (acoustic doppler current profiler) and water quality using a multiparameter sensor. All three sensors are mounted on the USV. A visual target is mounted on the USV and a camera mounted on the UAV is used to track the visual target. This will allow improved positioning of the USV in areas with poor GNSS signal.
- The second is carried out by the UAV alone. It consists of recording underwater topography using a bathymetric LiDAR. A camera placed on the UAV may also be used to record the surface flow velocity. This can be used to estimate river discharge.
- The third is to produce a Digital Terrain Model using a digital camera mounted on the UAV.
- The fourth is to record shore vegetation types using the panoramic camera mounted on the USV.

## 1.2 UAV/USV tandem mode

Before the River Cloud project, a similar project called “RiverView” was carried out with the goal of monitoring water parameters and depth as well as acquiring 360°-panorama images [1]. It was found that in certain circumstances, GNSS positioning accuracy was seriously affected by features such as tall buildings and trees on the shore or the presence of bridges. Overcoming this issue required the use of a total station placed on the shore and a prism placed on the USV. Although this solution provides optimal accuracy, it presents drawbacks and limitations. Using a total station, range is limited to line of sight locations and a single stretch of river may require the total station to be repositioned several times, resulting in a much slower survey process. Moreover, in certain situations, It may not be possible to find a suitable location for the total station due to terrain, obstructions or property law.

The RiverCloud project requires the presence of a UAV (Unmanned Aerial Vehicle) to fulfill certain missions such as aerial photogrammetry and river flow velocity measurement. When the USV is required to perform surveys in areas with poor GNSS signal, it is therefore possible to use the UAV equipped with a camera as well as visual markers placed on the USV to deduce the position of the USV using data from sensors placed aboard the UAV as well as the images taken by the camera. To achieve this, the UAV must fly while the USV carries out its surveying task. This is referred to as “tandem mode”. As result, the position of the USV can be calculated in real-time. In addition to enabling autonomous operation of the UAV, this eliminates the need to save the image data from the tracking camera, the size of which could grow to be very large.

An estimate of the position and state of the USV in real-time is to be further refined by fusing data from sensors onboard the USV. These include a dual antenna GNSS system, inertial measurement unit (IMU) and one or more stereo camera systems. For improving positioning in post-processing it is possible to use image data from a panoramic camera. The goal of real-time state estimates for

several vehicles simultaneous can be achieved by using a Robot Operating System (ROS) network connecting both vehicles with a Ground Control Station (GSC).

## 2 ROS – Robot Operating System

The Robot Operating System (ROS) is a flexible framework for writing robot software. It is a collection of tools, libraries and conventions that aim to simplify the task of creating complex and robust robot behaviour across a wide variety of robotic platforms. The ROS framework allows research groups and individuals to make use of each other's work. ROS is not an operating system in the traditional sense. Rather, it provides a structured communications layer above the host operating system for a heterogeneous compute cluster [2]. ROS was originally designed to meet the challenges faced by researchers at Stanford University and Willow Garage when developing service robots. It has since been shown to be applicable to a range of challenging endeavours such as autonomous drone flight, Autonomous Surface Vessels (ASVs), self-driving cars and robotic industrial manufacturing.

## 3 USV – Unmanned Surface Vehicle

The Hydrosurv Reav-16 USV is equipped with various sensor for autonomous positioning as well as for data collection of the water body both above and under water.

### 3.1 Sensors

The Sonic 2020 multibeam echosounder (MBES) manufactured by R2Sonic is used to measure bathymetry. This MBES has a resolution of  $2^{\circ} \times 2^{\circ}$  at 450kHz and  $4^{\circ} \times 4^{\circ}$  at 200kHz. The speed of sound at different depths needs to be measured in order to produce accurate survey data in bodies of water with variations in temperature and/or salinity at different depths. To determine this, a Swift Sound Velocity Profiler (SVP) is used. The speed of sound can be both directly measured using transducers or inferred from measurements of pressure, temperature and conductivity.

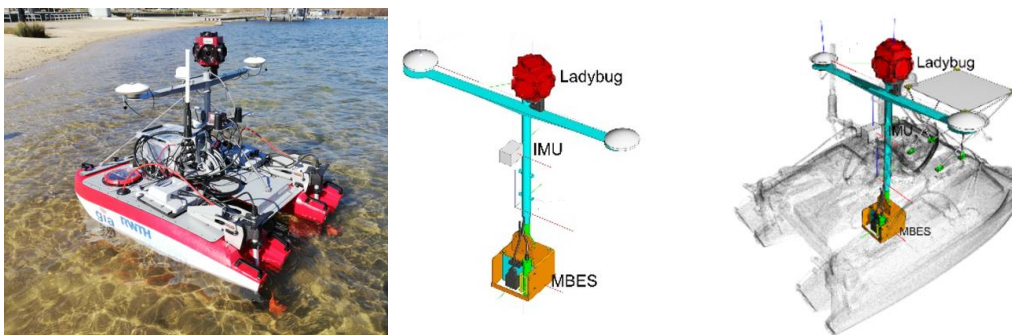

Figure 1: USV at the testing ground (left); Sensor configuration (middle & right)

The Novatel CPT7 combines an RTK-capable OEM7 dual antenna GNSS with a Honeywell HG4930 Micro Electro Mechanical System (MEMS) Inertial Measurement Unit (IMU). It can provide centimeter-level positional accuracy when GNSS signal is of sufficient quality. In the presence of poor GNSS conditions, it combines GNSS measurements with IMU measurements to provide a filtered state estimate. It also provides a heave estimate.

The Ladybug 5 panoramic camera combines six global shutter 5MP Sony ICX655 CCD sensors with fisheye lenses in a single housing. It can be connected to a computer via a single USB3 cable.

Figure 1 shows sensors installed onboard the USV.

Another camera system that is to be used additionally for position estimation purposes when GNSS is not usable is omitted in Figure 1 as it is still under development and not yet installed. The stereo system uses two OnSemi, global shutter 0.3MP MT9V022 sensors with 2.8mm or 6mm lenses both triggered simultaneously by an ARM Cortex-M4-based microcontroller. It is connected to a single board computer via two USB cables. The baseline between the cameras can be modified to be either 0.1m, 0.2m or 1m. Figure 2 shows a schematic of the stereo system.

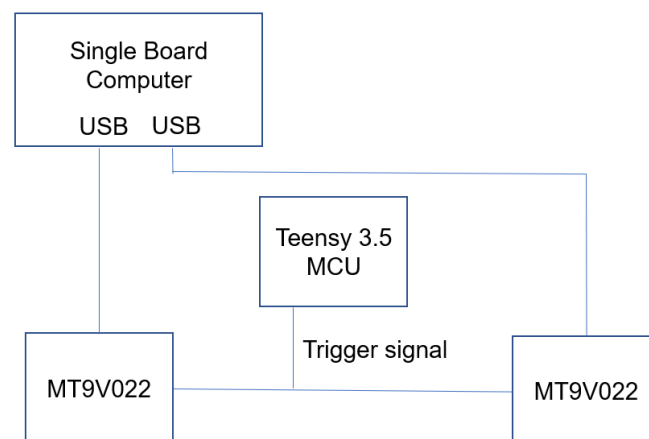

Figure 2: Stereo system diagram

### 3.2 Software

Qinsy is a survey planning, data acquisition, and real-time hydrographic data processing software package produced by Dutch company QPS. In order to acquire bathymetric data, Qinsy is interfaced with the MBES and Novatel GNSS+INS. This setup has the capability to measure bathymetry as well as provide data regarding river bed morphology and water column characteristics.

Teledyne FLIR, the manufacturers of the Ladybug 5 camera, provide the LadybugCapPro software. This application can be used to modify setting, record data and perform post processing tasks such as image rectification, image quality optimisation and image stitching.

In order to use images from the panoramic camera within the ROS network, a custom node is able to read the timestamps of the trigger pulses, convert the relevant images into ROS format and publish them on the ROS network.

## 4 UAV – Unmanned Aerial Vehicle

The Avartek boxer hybrid UAV is equipped with an RTK-capable Emlid M2 GNSS module and a Cube Orange IMU/barometer. For the purpose of tracking the USV, a Ximea 20MP camera is mounted on a Gremsy T7 gimbal. For photogrammetry missions, a Phase One ix M100 camera is used. For aerial bathymetric mapping, a Riegl BDF-1 can be deployed.

## 5 Simultaneous operation of USV and UAV

During tandem mode operation, an ix M100 camera located on the UAV is pointed towards nadir with the help of a gimbal. A Xavier NX computer located on the UAV detects two AprilTag markers placed on the USV and directs the UAV to fly vertically above the USV. Using the AprilTag markers in the image and the sensors on the UAV, the USV position is estimated.

For testing, a STIL (Software in the loop) simulator is initially used to simulate the UAV's Arducopter flight controller. The boat tracker node runs on the Xavier NX's GPU which is directly connected to the camera in order to speed up image processing. This node detects the markers and estimates the range to the USV as well as the position and attitude of the USV.

## 6 Inter-vehicle communication

In tandem mode, the surveying system consists of a UAV, a USV and a single GCS (ground control station). Command and Control of both vehicles as well as monitoring data acquisition is carried out from the laptop, which acts as the GCS.

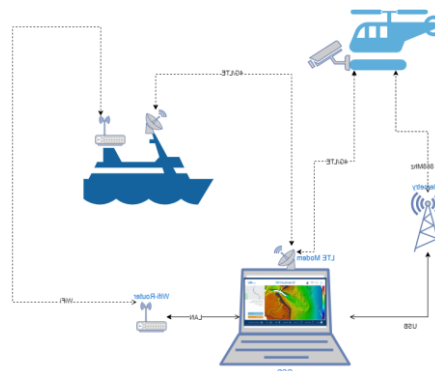

Figure 3: Diagram of inter-vehicle communication

Figure 4 shows the communication methods between the UAV, the USV and the GCS (ground control station). The UAV communicates with the GCS through an LTE modem and a 868Mhz telemetry link. In addition, a 2.4GHz Herelink system is used by the UAV pilot for video transmission and remote control. The USV communicates to the GCS through both an LTE modem and a Wifi connection. The wifi router allows multiple laptops to be connected simultaneously if necessary. There is no direct data link between the UAV and the USV.

## 7 Sensor fusion algorithm

Use of a ROS network facilitates the implementation, modification and testing of various existing algorithms. Methods tested so far include “Robot Localization”, which is a collection of Kalman Filters, “Rovio”, “ORB-SLAM2” and “ORB-SLAM3” which are visual odometry/SLAM algorithms and the “Aruco”, “Alvar” and “AprilTag” visual marker generation and detection methods. [3]

In the absence of the UAV, the position estimate of the USV is to be performed using “Robot Localization” and “ORB-SLAM3” [4]. In the presence of the UAV, an additional Marker detection algorithm based on AprilTag is used.

“Robot Localization” [5] is a ROS package created to estimate the state of robots through sensor fusion. It is versatile and has been applied to drones [6], deep sea Remotely Operated Vehicles (ROVs) [7] and bathymetric survey vessels [8]

The Robot Localization package contains an implementation of an Extended Kalman Filter (EKF). An unlimited number of inputs from multiple sensors can be fused using this package. It supports position, orientation, linear velocity, angular velocity and linear acceleration inputs. The package’s output is an estimation of the robot’s position, attitude, velocity and angular velocity.

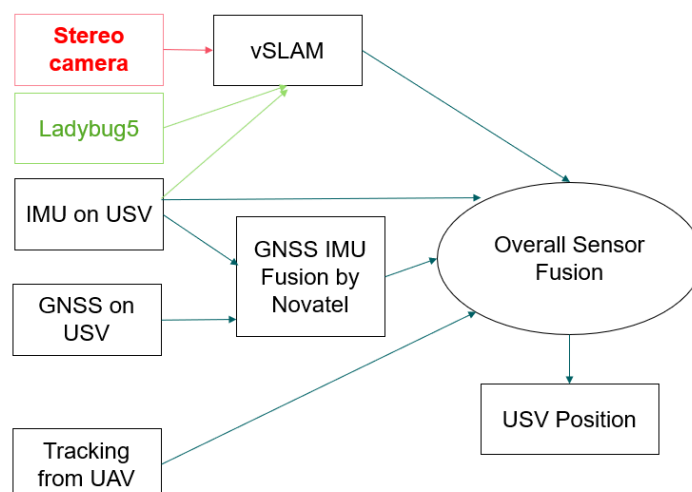

Figure 4: Sensor fusion methods using stereo (red) and monocular (green) visual odometry

The ORB-SLAM3 package is able to perform visual, visual-inertial and multi-map SLAM with monocular, stereo and RGB-D cameras, using pin-hole and fisheye lens models. Experiments performed by the ORB-SLAM3 authors have shown that, in all sensor configurations, ORB-SLAM3 is as robust as the best systems available in the literature and significantly more accurate. We shall be testing the stereo version of ORB-SLAM3 using lenses with various focal lengths incl. 6mm and 2.8mm as well as various baselines between the two cameras incl. 10cm, 20cm and 1m. Another possible sensor fusion method involves using images from the panoramic camera to perform monocular visual odometry and scaling the resultant track using data from other sensors such as the IMU. Figure 6 shows monocular visual odometry on a test dataset using images from the panoramic camera.

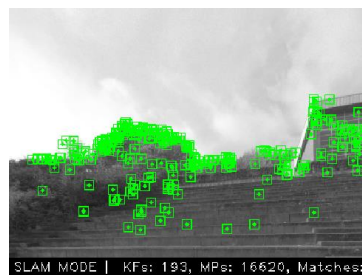

Figure 5: Monocular visual odometry test using panoramic camera

Two separate EKFs run onboard the UAV. One is used for estimating the state of the UAV and fuses data from two GNSS sensors, an IMU and a barometer. A second EKF is used to estimate the position and orientation of the camera. In addition to using the output of the previously described EKF, it integrates data from the gimbal encoders, the gimbal IMU and optical flow data derived from the camera.

## 8 Evaluation

Various surveys with only the USV were conducted on a lake near Aachen. These tests confirmed that the bathymetric survey system operated as expected (Figure 7). It also confirmed that it was possible to access data from the Novatel IMU through a ROS network running on a laptop with Ubuntu 18 and ROS Melodic. It was possible to create a rosbag file on the laptop.

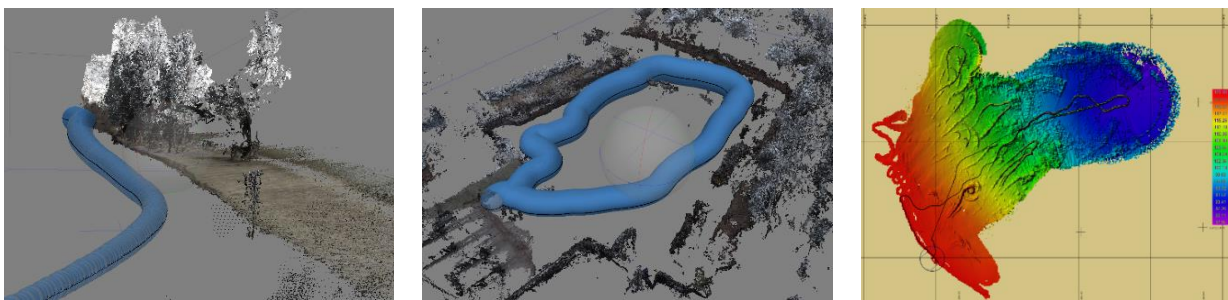

Figure 6: Pointclouds created (left & middle); Bathymetric map created using MBES (right)

## Acknowledgement

This research is funded by the German Federal Ministry of Digital and Transport, research initiative mFund, grant number: 19F2121A. We would like to thank you for the good cooperation at our project partners: Forschungsinstitut für Wasser- und Abfallwirtschaft e. V, IAV GmbH Ingenieurgesellschaft Auto und Verkehr, SEBA Hydrometrie, Orthodrone, Bundesanstalt für Gewässerkunde, Bundesanstalt für Wasserbau.

## References

- [1] R. Schwermann, C. Effkemann, N. Hein, G. Kutschera, J. Blankenbach, “Riverview - Monitoring of water parameters in small and medium-sized water bodies using USV”, 126. 136-146. 10.5675/HyWa\_2018.6\_5.
- [2] Quigley, Morgan & Conley, Ken & Gerkey, Brian & Faust, Josh & Foote, Tully & Leibs, Jeremy & Wheeler, Rob & Ng, Andrew. (2009). “ROS: an open-source Robot Operating System. ICRA Workshop on Open Source Software. 3.”
- [3] Olson, Edwin. (2011). “AprilTag: A robust and flexible visual fiducial system. Proceedings - IEEE International Conference on Robotics and Automation.” 3400 - 3407. 10.1109/ICRA.2011.5979561.
- [4] Campos, Carlos & Elvira, Richard & Gómez Rodríguez, Juan & Montiel, José & Tardós, Juan. (2020). “ORB-SLAM3: An Accurate Open-Source Library for Visual, Visual-Inertial and Multi-Map SLAM.”
- [5] T. Moore and D. Stouch, “A Generalized Extended Kalman Filter Implementation for the Robot Operating System”, Proceedings of the 13th International Conference on Intelligent Autonomous Systems (IAS-13), 2014
- [6] F. Kucuksubasia and A.G. Sorguc, “Transfer Learning-Based Crack Detection by Autonomous UAVs”, 35th International Symposium on Automation and Robotics in Construction, 2018
- [7] Mueller et al., “Dexterous Undersea Interventions with Far Distance Onshore Supervision: the DexROV Project”, IEEE Robotics & Automation Magazine Volume: 25, Issue: 4, Dec. 2018
- [8] Makiello, “Using a ROS-based low-cost system for bathymetric surveys”, Hydrographische Nachrichten Ausg. 116, 2020