

TECHNISCHE UNIVERSITÄT MÜNCHEN

Lehrstuhl für Baurealisierung und Baurobotik

Automated and Robotic Construction: Integrated Automated Construction Sites

Thomas Linner

Vollständiger Abdruck der von der Fakultät für Architektur der Technischen Universität München zur Erlangung des akademischen Grades eines

Doktor-Ingenieur (Dr.-Ing.)

genehmigten Dissertation.

Vorsitzender: Univ.-Prof. F. Musso

Prüfer der Dissertation: 1. Univ.-Prof. Dr.-Ing. (Univ. Tokio) Th. Bock
2. Univ.-Prof. Dr.rer.pol. F. Th. Piller, Rheinisch-Westfälische Technische Hochschule Aachen
3. Univ.-Prof. Dr. techn. P. E. Mayer (i. R)

Die Dissertation wurde am 11.02.2013 bei der Technischen Universität München eingereicht und durch die Fakultät für Architektur am 03.05.2013 angenommen.

Abstract

The background and motivation for this thesis was – in the view of the author – the urgently necessitated focus on automation and robot technology based On-site Manufacturing technology in the construction industry. Current developments in construction, in the field of product structures (for example through modularity, Design for Manufacturing), organizational strategies (such as Just in Time, Just in Sequence, Pulling Production) and informational aspects (such as Computer Aided Design/Computer Aided Manufacturing or Computer Integrated Manufacturing) are slowed down or even prevented through the lack of a technologically adequate and integrated manufacturing technology for the construction site. The construction site itself is significant, as the possibility of fully manufacturing complex buildings off-site is limited, due to the nature of buildings (i.e. size, weight and fixed location). Therefore, the research question was set, focusing on counteracting the identified lack of manufacturing technology by installing automatic/robotic machining or assembly centers on the construction site (in this thesis called: Automated/Robotic On-site Factories), and turning the construction site into a factory-like, structured, manufacturing environment. Automated/Robotic On-site Factories represent computer controllable and flexible manufacturing technology that removes the necessity for back and forth conversion from digital to analog information on-site, and is able to integrate and unfold the potential of all of the above mentioned complementary fields.

Based on the research question, and based on the knowledge and experience the author has gained through nearly six years in research, during which he contributed to a series of research projects covering all of the above mentioned fields, a variety of hypotheses were discussed. Firstly, it was discussed why and to what extent structured on-site environments outperform stand-alone technological solutions, such as prefabrication or single-task construction robot technology. Secondly, it was discussed how Automated/Robotic On-site Factories can be designed to manufacture all building topologies, and how they can be advanced to set up a construction industry which can deliver products in a near real-time manner. Thirdly, it was discussed why the novel technology – the more radical solutions – requires a drastic and co-adapted change to manufacturing, technology, organization, products and associated business models in construction. Although the changes and resources necessary to deploy Automated/Robotic On-site Factories can be considered to be enormous, they can be efficiently accomplished on the basis of existing technologies, and the overcoming of the associated challenges might eventually be able to turn the construction industry into an incubator for future manufacturing technology.

In order to find answers to the search for a novel On-site Manufacturing technology, and in order to be able to discuss the stated hypotheses, related terms and concepts were introduced and analyzed and the developments in off-site Building Component Manufacturing and Large Scale Prefabrication, as well as in other industries that manufacture complex products, existing approaches to automated/robotic on-site construction as Single-task Construction Robots and Automated/Robotic On-site Factories developed so far, were systematically identified and analyzed qualitatively and quantitatively. The analysis showed that basic technological elements for the deployment of Automated/Robotic On-site Factories are available but compared to productivity and efficiency improvements that accompanied the introduction of advanced manufacturing technology in other industries, the improvements accomplished by Automated/Robotic On-site Factories developed so far can still be considered as marginal. Henry Ford in contrast, for example, radically reduced lead time from weeks down to days and finally down to eight hours when he shifted from a crafts based to a systemized and machine based approach for manufacturing its Model T. Today, modern automation technology allows the production of much more complex automotive products with lead times of less than three-and-a-half hours (e.g. final assembly of the Smart car produced in Hambach/France).

Therefore, based on the identification of the strengths and weaknesses of 30 Automated/Robotic On-site Factories developed worldwide so far, in an exploratory study, novel possibilities for the deployment of highly structured on-site factory environments that reduce (as a basis for the successful implementation of automation and robotics) the on-site work task spectrum and work task complexity to a minimum, were tested. The proposed novel target system integrates off- and On-site Manufacturing technology and suggests a novel OEM-like industry structure for the construction industry. Automated/Robotic On-site Factories in various scenarios function as Original Equipment Manufacturers and create the basis for uninterrupted on-site production-line-like material flow (removing any idle time from the construction site, and thus allowing the full utilization the capacity of the machine technology), maximum reduction of on-site activities (including human labor) and activity complexity, and an extensive use of modularity. The proposed target system aims at reducing the time requirements to construct a complex building product as a high-rise building down to roughly one-tenth of the time required to construct a similarly complex building using conventional crafts based construction methods. Systematic variants of the target systems are developed, embedded into various expected future industry requirements scenarios and evaluated. A reference for the novel target system proposed was the plan of a major Korean company (with which the research institute of the author is in contact) to construct its company headquarters with more than 100 floors in Seoul by automated on-site technology, at a performance of more than one floor per day. This approach will later be used all over Korea (which has a huge demand for high rise buildings) as well as in Japan, where, as a result of the Tohoku earthquake, all major high-rise buildings will have to be deconstructed and re-constructed over the next decade under the premise of minimal building deconstruction and down-time demands. Similarly, the approach, can be utilized in metropolitan regions (e.g. in China) where skyrocketing demand for housing and building costs require novel solutions.

It is shown in the thesis, that the proposed novel target system would be able to counter the worldwide decrease of productivity and quality in construction. Technologically leading industrial nations (Germany, Japan, Korea, Scandinavian countries, the UK) but also emerging industrial nations such as China or Russia would profit from a strong technological orientation of the construction sector, by using it to strengthen the demand for their frontier technologies. A more complex novel construction technology could also create a competitive advantage, as it reduces the possibility of business fields being taken over or processes and technologies being imitated by competitors. Furthermore, the world's population growth and increasing demand for resources increasingly require construction in harsh environments (ocean, arctic areas, deep sea, deserts, and space). Large structures in those environments could be constructed by the proposed approach quickly and efficiently, and without interruption to which human work is usually subject to in those environments.

Furthermore, in this thesis, various innovation and technology management methods relevant to the realization of the proposed target system are systematically identified and discussed. It is shown that not only the opening up of novel markets in the construction industry could be of interest for technology providers, such as mechatronics and robotics manufacturers currently aiming at advancing their business to novel industry fields, but that concepts and technologies developed for automated construction hold a potential to be diffused into other manufacturing industries afterwards. As for the construction of extremely flexible, cost effective and robust manufacturing systems are in demand that allow the automatic (final) assembly of highly complex but individualized products; the construction industry could be used as a test bed for future manufacturing systems in general. Although the focus of this thesis was set on identifying, analyzing and advancing a novel On-site Manufacturing technology, it is also shown and discussed that a radical change in manufacturing technology also necessitates a radical and complementary change in product structures, organizational aspects and informational aspects. In particular, a steady increase in the product's complexity, its structure, quality and performance in construction is key to generating the necessity and demand for the proposed novel manufacturing technology. The author of this thesis intends to focus more on this aspect in future research.

Acknowledgements

First of all, I would like to extend my deepest gratitude to **Prof. Dr.-Ing. T. Bock**, my principal supervisor and guide in many respects, for his constant support and guidance throughout the last six years and for opening up so many doors. The work in his laboratory and the related participation in real-world research projects jointly conducted with industry, studies and consultancy reports, expert groups, conferences, teaching activity and countless site visits to top scientific institutions, research departments and factories around the world, has steadily equipped me with the information and tools that finally enabled me to write this thesis. It has to be mentioned that I feel honoured to be able to carry on a research direction and technological development with this thesis, for which the concept of **Robot Oriented Design**, the focal point of his doctoral thesis at The University of Tokyo, built the backbone. Prof. Dr.-Ing. T. Bock's many deep, personal and professional relationships with inventors, researchers and developers in the scientific and professional field key to the development of the Automated/Robotic On-site Factory approach (the focal point of this thesis) from the very beginning onwards, together with the information he equipped me with and the countless scientific discussions we had on the topic, have enabled me to complete the research summarized and presented in this thesis.

I would like to express my very sincere gratitude to **Prof. Dr. F. T. Piller**, whose rich and fascinating scientific work and publications in the field of Mass Customization inspired me, particularly at the beginning of my academic work, to search for ways to introduce such ideas into the construction field, and thus nurtured the development of my view on the construction industry as a manufacturing industry capable of producing advanced products and services. I would also like to express my very sincere gratitude to **Prof. Dr. P. E. Mayer** for his wise and precise advice from a construction management professional's and application oriented view, which was, from time to time, important in bringing visionary ideas down to earth. I express my very sincere gratitude to **Prof. F. Musso** for consistently sharing his research interest in industrialization in architecture and construction with me and motivating me to follow my research goals. I offer my very sincere gratitude to **Prof. Dr. K. Endo** for his support in many aspects during his one-year visiting professorship at the laboratory. He supported me considerably, both in personal and informational respects in the final and "hot" phase of writing this thesis. I am also sincerely grateful to **Prof. Dr. O. Maier** for the multitude of interesting discussions about industrialization and the use of machine technology in construction I had with him.

I am indebted to my colleague and "strategic advisor" **Dr.-Ing. C. Georgoulas** who shared with me his long scientific experience and personal integrity and equipped me with the tools that allowed me to reduce complexity during writing and put things in a systemic scientific framework. Without his care and advice, the finalizing of this thesis would have been impossible.

I thank the AUSMIP Consortium and the Professors and Institutions involved and related to them for supporting my research. In particular, I extend my thanks to **Prof. Dr. S. Matsumura, Prof. Dr. T. Yashiro, Prof. Dr. S. Murakami, Dr. S. Chae, Prof. Dr. S. Kikuchi, Assistant Prof. Dr. K. Shibata, Prof. Dr. H. Shimizu, Prof. Dr. S.-W. Kwon, Prof. Dr. M.-Y. Cho, Prof. Dr. D.-H. Hong, Prof. Dr. H.-H. Cho, Prof. A. Deguchi and Prof. B. Peeters** and their students and assistants for supporting me with information and organizing and enabling a multitude of important site visits. Furthermore, I gratefully acknowledge the **International Association for Automation and Robotics in Construction (IAARC)** whose yearly conferences, activity, publications and network provided a fruitful ground for my research and a motivation to follow my research direction. Furthermore, I gratefully acknowledge all institutions, companies and persons involved in the R&D consortia **LISA, GEWOS and PASSAge** and the institutions that financed and backed them (**BMBF, VDI, VDE and Innovation Alliance AAL**). Through the work in those projects, I acquired the ability to cope with the complex technology and innovation management challenges faced during the conducting of the research presented in this thesis.

I am sincerely grateful to my colleagues **A. Bittner, B. Pascalau, B. Georgescu, W. Pan, J. Meyer-Andreas, I. Arshad, T. Zhang, M. Avina and M. Rahaman** for their support, advice and friendship. I am also thankful to the innumerable international guest scientists and researchers that worked with me, and shared their knowledge. In particular, I would like to thank our (present and former) guest researchers and supporters **Dr. S. Y. Lee, K. Iturralde, A. Shrikathiresan, W. Ikeda and S. Miura**.

Last but not least, I would like to express my very sincere gratitude to my father **N. Linner**, an experienced "architectural manager" who consistently motivated me to head into new directions, change today's old-fashioned architectural and construction practice and to follow my goals. Furthermore, he provided me with personal and professional advice whenever I was in need.

Contents

Chapter	Topic	Page
1.	Background, Research Question, Research Method	1
2.	Introduction of relevant Terms, Concepts and Technologies	49
3.	Off-site Technologies necessary for an OEM-like Industry Structure in Construction and Manufacturing of Complex Products in other Industries	95
4.	Development of Elementary Technology (Single-Task Construction Robots, STCRs) and Transition to Integrated Automated Sites	131
5.	Integrated Automated/Robotic On-site Factories	181
6.	Towards real-time and building-integrated Automated Construction	391
7.	Acceleration of strategic and technological Development by R&D and Innovation Methodology	465
8.	Conclusion, Future Research	513
	References	523

1	Background, Research Question, Research Method	1
1.1	The Role of Complementarity of Products, Organization, Information and Machine Technology	3
1.2	Current State of Product Structures in Construction.....	7
1.3	Current State of Organization and Management in Construction	11
1.4	Informational Aspects in Construction.....	15
1.5	State of the Art Machine Technology in Construction	21
1.5.1	The Roots of Component Manipulation in the Middle Ages.....	25
1.5.2	<i>Bauschiffe</i> (from 1910 onwards)	28
1.5.3	Mechanized On-site Construction in Russia (since the 1940s)	30
1.5.4	7-Degrees of Freedom Manipulator Kinematics for Construction Purposes: Location Orientation Manipulator (1969)	32
1.5.5	Fusion of Prefabrication and Lifting Technology: BMW-Tower (1972).....	33
1.5.6	Zuse's Extendable/Retractable Helix Tower (1985-1995)	34
1.6	Research Question and Hypotheses: Focus on Machine Technology	35
1.7	Research Method and Structure of this Thesis	41
2	Introduction of Relevant Terms, Concepts and Technologies	49
2.1	Productivity, Efficiency and Economic Performance	51
2.2	Multilevel Modularity (Products, Processes, Organization and Machines)65	
2.3	Technology and Organization in Manufacturing.....	73
2.4	Automation and Robot Technology	85

3	Off-site Technologies Necessary for an OEM-like Industry Structure in Construction and Manufacturing of Complex Products in Other Industries	95
3.1	Building Component Manufacturing (BCM).....	97
3.2	Large-scale Prefabrication (LSP).....	101
3.2.1	Influence of Product Structure on Material Flow.....	103
3.2.2	Influence of Product Structure on Stations, End-effectors and the Factory internal Automation Ratio.....	104
3.2.3	Influence of Product Structure on on-site Assembly and the overall Degree of Automation.....	104
3.2.4	OEM-like Integration Structure.....	105
3.2.5	Efficiency/Productivity.....	107
3.2.6	R&D and Innovation Aspects	110
3.2.7	Flexible Degree of Customer Integration	110
3.2.8	Weaknesses of the Japanese LSP Industry.....	110
3.3	Complex Products in other Industries and Relevance of Fixed-Site/ONM Technology	113
3.3.1	Tunnelling by Tunnel Boring Machines (TBMs).....	113
3.3.2	Shipbuilding	115
3.3.3	Aircraft Manufacturing.....	118
3.3.4	Automotive Manufacturing	121
3.3.5	Comparative Analysis.....	123
3.3.6	Performance Multiplication by Mechanization, Automation and Robot Technology.....	124
3.4	Conclusion: Systematization of final Assembly by Combination of OEM and Factory Approach	127
4	Development of Elementary Technology (Single-Task Construction Robots, STCRs) and Transition to Integrated Automated Sites ..	131
4.1	Single-Task Construction Robots (STCRs).....	133
4.1.1	Earth and Foundation Work	138
4.1.2	Reinforcement & Rebar Production & Positioning	139
4.1.3	Concrete Distribution	140

4.1.4	Concrete Compaction	142
4.1.5	Concrete Levelling	143
4.1.6	Concrete Finishing	145
4.1.7	Site Logistics	147
4.1.8	Positioning of Components (Crane End-effectors)	149
4.1.9	Steel Welding	151
4.1.10	Facade Installation	152
4.1.11	Tile setting	154
4.1.12	Facade Painting	155
4.1.13	Interior Finishing	157
4.1.14	Fireproof Coating	159
4.1.15	Service, Maintenance and Inspection	160
4.1.16	Renovation and Recycling	162
4.2	Transition and Technological Reorientation towards Integrated On-site Manufacturing (ONM)	165
4.2.1	Development and Refinement of Automated On-site Logistics	166
4.2.2	Development of Climbing Robots	168
4.2.3	Refinement of Site-cover Technology	169
4.2.4	Introduction of Simulation and Real-Time Monitoring Technology in Construction	170
4.2.5	Introduction of Robot Oriented Design strategies in Construction	171
4.2.6	First Concepts for Integrated Sites: Cooperating Single-task Construction Robots	173
4.2.7	First Concepts for Integrated Sites: Factory Approach	175
4.3	Conclusion: From standalone Solutions to Systems integrated by Structured Environments	179
5	Integrated Automated/Robotic On-site Factories	181
5.1	Framework for technical Analysis	183
5.2	Technical Analysis & Categorization: Construction	185
5.2.1	Sky Factory (moving upwards) – supported by building	187
5.2.2	Sky Factory (moving upwards) on Stilts (extending)	223

5.2.3	Sky Factory Pulled up by Core (main factory and core factory moving upwards).....	233
5.2.4	Ground Factory (fixed location, vertically oriented building) and Building Push-up.....	243
5.2.5	Ground Factory (fixed location, horizontally oriented building) and Building Push-up.....	249
5.2.6	Off- and On-site Combined Factory (both in a fixed location)	261
5.2.7	Self-supported Ground Factory (horizontally moving)	267
5.2.8	Sky Factory (moving upwards) for Simple Tower Manufacturing	277
5.2.9	Centralized Sky Factory (moving upwards) in Combination with Conventional Construction.....	287
5.2.10	Decentralized Sky Factory (moving upwards) in Combination with Conventional Construction.....	297
5.3	Technical Analysis & Categorization: Deconstruction	307
5.3.1	Closed Sky Factory Supported by Building (moving downwards).....	309
5.3.2	Open Sky Factory Supported by Building (moving downwards)	321
5.3.3	Ground Factory (fixed place) and Building Lowering	335
5.4	Efficiency Analysis	341
5.4.1	Analysis Framework	341
5.4.2	Analysis According to Framework	343
5.5	Conclusion: Discrepancy between technical Capability and Efficiency	385
6	Towards Real-time and Building-integrated Automated Construction.....	391
6.1	Achievement of a Novel Level of Productivity and Efficiency by the Consequent use of Technology	393
6.1.1	General concept for target system.....	394
6.1.2	Uninterrupted and production-line-like material flow on-site	394
6.1.3	Maximum reduction of on-site activities and activity complexity	395
6.1.4	Maximum reduction of on-site construction time	397
6.1.5	Consequent deployment of modularity, self-adjusting and fast connector technology.....	401
6.1.6	Identification of novel elementary technology.....	403
6.1.7	Systemic development and discussion of approaches (Approach 1-4)	406

6.1.8	Relevance of the super-structure/sub-structure approach for target system	407
6.1.9	Through modular coordination to Approach 5	409
6.1.10	Sensor systems and AAMS	416
6.1.11	Analysis of construction speed of variants of target system	420
6.1.12	Analysis of evolution scheme of target system	421
6.1.13	Life-cycle and Building Integrated Manufacturing (Approach 6)	423
6.1.14	Comparison of various approaches for automated and non-automated construction by value analysis (scoring-model).....	426
6.1.15	Generation of novel business opportunities by automated construction: space structures, marine structures, arctic structures, sub-marine structures, desert structures.....	430
6.2	Synchronization of Organization, Building Structure and Manufacturing Technology by Robot Oriented Design.....	433
6.2.1	From Design for X (DfX) to Robot Oriented Design (ROD).....	433
6.2.2	Designing within capabilities of the manufacturing system.....	439
6.2.3	Dimensions of for and based through ROD.....	445
6.2.4	Reduction of kinematic/mechatronic complexity	445
6.2.5	Reduction of sensor, process measuring and control complexity	446
6.2.6	Reduction of organizational complexity	447
6.2.7	Reduction of Gripper-/End Effector Complexity.....	449
6.2.8	Reduction of information/computational complexity.....	452
6.2.9	Reduction of complexity throughout life cycle	453
6.2.10	Complexity reduction along the value chain by ROD	454
6.2.11	Application of ROD in various architectonic scales.....	460
6.3	Conclusion: Novel ONM technology necessitates drastic Change of Industry and its Products	463
7	Acceleration of Strategic and Technological Development by R&D and Innovation Methodology	465
7.1	Roadmap to Economic Feasibility of Automated/Robotic On-site Factories	467
7.1.1	Definition of parameters relevant for economic feasibility.....	468
7.1.2	Economic feasibility on different levels.....	472
7.1.3	Future Funding Program Strategy	474

7.2	Utilizing Innovation Science to Develop and Deploy Automated/Robotic On-site Factories.....	479
7.2.1	Innovation Mechanisms in General	479
7.2.2	Innovation Mechanisms in Construction.....	482
7.2.3	Realizing Innovation in Construction by 7-Dimensional View	486
7.2.4	Augmentation of discussed Approaches (1-6) by advanced Technologies and Strategies	488
7.3	Reverse Innovation – Using the Construction Industry as an Incubator for Future Manufacturing Systems.....	499
7.3.1	Current Strategy of Automation and Robot Technology Providers	499
7.3.2	The Idea of Reverse Innovation.....	501
7.3.3	Advanced Approaches to be Re-transferred from Automated Off/On-Site Construction.....	502
7.4	Conclusion: Concept of Life-cycle Integrated Manufacturing Technology	509
8	Conclusion, Future Research	513

References 523

Glossary

A

Assembly: Production of higher-level components or final products out of parts and lower-level components. The process of assembly of an individual part or component to a larger system involves positioning, alignment and fixation operations. Upstream processes dealing with the generation of elements and processes within assembly are referred to as production.

Alignment and Accuracy Measurement System (AAMS): An AAMS creates a feedback loop between a system that measures how accurate components are positioned and an alignment system (for example a motorized unit attached temporarily to the joint of a column component) that automatically moves or aligns the component into the desired final position.

Automated Guided Vehicle (AGV): Computer controlled automatic or robotic mobile transport or logistics vehicle.

Automated/Robotic On-site Factory: Structured factory or factory-like environment set up at the place of construction, allowing production and assembly operations to be executed in a highly systemized manner by, or through, the use of machines, automation and robot technology.

B

Batch Size: The amount of like or similar products produced without interruption before the manufacturing system is substantially changed to produce another product. Generally speaking, low batch sizes are related to high fixed-costs and high batch sizes are related to low fixed-costs.

Building Component Manufacturing (BCM): BCM refers to the transformation of parts and low-level components into higher level components by highly mechanized, automated or robot supported industrial settings.

Building Integrated Manufacturing Technology: Automation technology, microsystem technology, sensor systems or robot technology can be directly integrated into buildings, units or components as a permanent system. Technology used to manufacture the building can thus become a part of the building technology.

Bundesministerium für Bildung und Forschung (BMBF): Federal Ministry of Education and Research. The BMBF funds education, research and technical development in a multitude of industrial fields.

C

Capital Intensity: The capital intensity (also referred to as workplace cost) is calculated by dividing the capital stock (assets, devices and equipment used to transform/manufacture the outcome) by the number of employees in the industry. The construction industry has not only one of the lowest capital stocks, but capital intensity is by far the lowest compared to other industries in Germany.

Chain-like Organization: In a chain-like organization, individual workstations do not have a fixed flow of material, but a general directional flow of material (e.g. within a factory segment of a factory) is common.

Climbing System (CS): Automated/Robotic On-site Factories require, especially in the manufacture of vertically oriented buildings, a system which allows the *Sky Factory* (SF) to rise to the next floor level once a floor level has been completed. Most SFs, therefore, rest on stilts which transfer the loads of the SF to the building's bearing structure, or to the ground. Other CSs are able to climb along a central core, pushing up the building, or in the case of the manufacture of horizontally orientated buildings, for example, to enable the factory to slide horizontally. In some cases, in addition to climbing, CSs are used to provide a fixture or template for the positioning of components by manipulators. Due to the enormous forces necessary to lift SFs, hydraulic systems and screw presses are common actuation systems.

Closed Loop Resource Circulation: Systems for avoiding waste and reduction of resource consumption by integrating concepts such as reverse logistics, remanufacturing and recycling. Material or product flows on a factory level, utilization level and deconstruction level can be related back to the manufacturing system in order to close the loop.

Closed Sky Factory (CSF): *Sky Factory* (SF) which completely covers and protects the workspace in Automated/Robotic On-site Factories, thus allowing the installation of a fully *Structured Environment* (SE) that erases the influence of parameters that cannot be 100% specified (e.g. rain, wind).

Component: In a hierarchical modular structure, components can be divided into lower level components and higher level components. Components consist of sub-elements of parts and lower level components. Higher level components can be assembled into modules and units.

Component Carriers: Component carriers and pallets (special types of component carriers) play an important role in logistics. In many cases, parts, components or final

products cannot be directly handled or manipulated by the logistics system. Component carriers and pallets act as mediators between the handled material and the actual logistics system.

Computer Aided Quality Management (CAQM): Control of quality by software, made possible through the linking of manufacturing systems with computer systems.

Computer Aided Design/Computer Aided Manufacturing (CAD/CAM): From the 1980s on, the novel and highly interdisciplinary research and application field CAD/CAM was formed, which aimed at integrating computerized tools and systems from the planning and engineering field with manufacturing and machine control systems, in order allow for a more-or-less direct use of the digital design data for automated and flexible manufacturing. The field evolved further towards *Computer Integrated Manufacturing (CIM)*.

Computer Integrated Manufacturing (CIM): From the 1990s onwards, the combined *Computer Aided Design/Computer Aided Manufacturing (CAD/CAM)* approach evolved into the CIM approach. The focus was broader and the idea was that more and more fields and tools, and also business economic issues (e.g. computer aided forecasting or demand planning), could be integrated by computerized systems to form continuous process and information chains in manufacturing that spans all value adding nodes in the value system.

Connector System: The development of connector systems that connect complex components in a robust way to each other is a key element in complex products such as cars, aircrafts, and buildings in particular. In order to support efficient assembly, connector systems can, for example, be compliant or plug and play-like. Connector systems can also be designed to support efficient disassembly, re-manufacturing or recycling.

Construction: Activities necessary to build a building on-site. Construction, in this thesis, is interpreted as being a manufacturing process, and accordingly buildings are seen as products.

Cycle Time: Important on the workstation level: $\text{Cycle time} = \text{time} / \text{intended production volume}$. The cycle time refers to the time allowed for all activities performed by humans and machines at a workstation.

D

Degree of Freedom (DOF): In a serial kinematic system each joint gives the systems, in terms of motion, a DOF. At the same time, the type of joint restricts the motion to a rotation around a defined axis or a translation along a defined axis.

Depth of Added Value: The depth of added value (e.g. measured as a percentage of the total cost of the product) refers to the total amount of value adding activities, and thus in general to the amount of value adding steps, realized by the *Original Equipment*

Manufacturer (OEM) or final Integrator. A high depth of added value means that a large amount of value adding activities is being realized by the OEM (e.g. Henry Ford). A low depth of added value means that a low amount of value adding activities is being realized by the OEM (e.g. Dell, Smart).

Design for X (DfX): DfX strategies aim at influencing design relevant parameters in order to support production, assembly maintenance, disassembly, recycling and many other aspects related to the product's life cycle. In this thesis, DfX strategies are classified into four categories: DfX related to production, DfX related to product function, DfX related to product end-of-life issues and DfX related to business models. *Robot Oriented Design* (ROD) is seen as an augmentation or extension of conventional DfX strategies, consequently aiming more at the efficient use of automation and robot technology in all four categories.

Deutscher Kraftfahrzeug-Überwachungs-Verein (DEKRA): Major German consultant and surveyor association which evaluates technical artefacts, such as cars and buildings, and defines quality and the causes of defects.

E

Efficiency: Efficiency can be defined as the relationship between an achieved result and the combination of factors of production at input. Whereas productivity expresses an input to output ratio, with a focus on a single factor of production, efficiency considers multiple factors and their combination. Productivity can be an indication of efficiency, and efficiency itself for economic feasibility.

End-effector: The element of machines, automation systems or robot technology that makes contact with the object to be manipulated in manufacturing is called the end-effector. In most cases end-effectors are modularly separable from the base system.

F

Factory External Logistics (FEL): FEL refer to logistics systems that connect the supply network to the factory integrating and assembling the supplied parts, components, modules or units. FEL influences the organization of the manufacturing system, *Factory Internal Logistics* (FIL) and the factory layout.

Factory Internal Logistics (FIL): FIL refers to logistics systems that manipulate parts, components, modules, units or the finished product within a manufacturing set-up or factory, for example, for the transportation between various stations. Other examples

include mobile and non-rail-guided transport systems, overhead crane-type material transportation systems, fixed conveyor systems allowing a component carrier or the product itself to travel in a horizontal direction in fixed lanes, and fixed conveyor systems allowing a component carrier or the product itself to travel in a vertical direction in fixed lanes. Novel cellular logistics robots combine capabilities of the mobility type with horizontal and vertical transport capabilities and can travel freely and self-organize with other systems.

Factory Roof Structure: Structure which allows the workspace on the construction site to be covered, and thus creates the basis for structuring the environment. Often used as a platform for the attachment of other subsystems, such as a *Climbing System* (CS), *Horizontal Delivery System* (HDS) and *Overhead Manipulators* (OMs).

Final Integrator: Entity in a value chain or value system that integrates major components into the final product. Within the OEM model, the final integrator is called *Original Equipment Manufacturer* (OEM).

Fixed-site Manufacturing: *Off-site Manufacturing* (OFM) or *On-site Manufacturing* (ONM) system which stays at a fixed place during final assembly.

Floor Erection Cycle (FEC): Time necessary to erect a standard floor with an on-site factory.

Flow Line Organization: In a flow line organization the flow of material between individual workstations is highly organized and fixed, and a material transport system linking the stations exists.

Flow of Material: Refers to material and product streams in relation to space and time that take place during the completion of a specific product in a manufacturing system and the supply network connected to it.

Frame and Infill (F&I): F&I strategies are used in a variety of industries, including the aircraft industry, automotive industry and building industry. The idea of a F&I strategy is to use a bearing frame structure as a base element that is subsequently equipped with parts, components, systems, modules, etc. during the manufacturing process. The frame thus functions as a component carrier. In the aircraft industry, the fuselage is interpreted as such a frame, in the automotive industry it is the car body or chassis, and in the building industry it can be seen with, for example, two-dimensional (e.g. Sekisui House) or three-dimensional steel frames (Sekisui Heim).

G

Ground Factory (GF): Structured factory or factory-like environment set up on the construction site on the ground level of the building as part of an *Automated/Robotic On-site Factory*.

Group-like Organization: In a group-like organization, individual workstations are bound together in groups. Those groups can refer to workstations with similar means of production or to workstations with complementary means of production.

H

Horizontal Delivery System (HDS): System that transports, positions and/or assembles parts/components on the construction site on a floor level.

I

Idle Time: The unproductive standstill of a machine from end of completion to the beginning of the processing of the next material. Bottleneck operations may – when workstations are directly connected without a buffer – lead to other workstations that are faster in processing the material having to wait for a certain time until the next material can be processed, resulting in an unproductive standstill of this workstation.

Inbuilt Flexibility: The changes in a manufacturing system can be realized without major physical changes (e.g. exchange of systems, workstations, robots, end-effectors, etc.), but by reprogramming the existing system instead. A standard robot with 6 *Degrees of Freedom* (6-DOF robot) with an end-effector for welding, for example, has a high degree of flexibility and it can be reprogrammed for a variety of welding operations of different products.

J

Joint of a Manipulator: A manipulator consists of at least one kinematic pair consisting of two rigid bodies (links) interconnected with a joint. The following types of joints can be distinguished: Revolute joint, Prismatic joint and Spherical joint.

Just in Time (JIT): Stocks and buffers are eliminated, and parts, components and products are delivered from upstream to downstream work stations at the right time and at the right quantity. JIT can be performed internally within a factory, or in relation to a supplier of an *Original Equipment Manufacturer* (OEM).

Just in Sequence (JIS): Various parts, components and products are delivered from upstream to downstream work stations in the sequence in which they are handled or

processed when they reach the downstream work stations. JIS can be performed internally within a factory or in relation to a supplier of an *Original Equipment Manufacturer* (OEM).

K

Kinematic Base Body: The combination of links and joints forms kinematic bodies with a geometrically definable work space (for example cartesian manipulator, gantry manipulator, cylindrical manipulator, spherical manipulator). Those kinematic base bodies consider mainly the first three axes, and thus refer mainly to positioning activity. For orientation, further *Degrees of Freedom* (DOFs) and kinematic combinations can be added on top of those base bodies.

Kinematic Body Positioning and Orientation: For unrestricted positioning of an object within a defined space, or within x, y, or z coordinates, at least 3 *Degrees of Freedom* (DOFs) are necessary (also referred to as forward/back, left/right, up/down). For unrestricted orientation of an object around a “tool center point”, at least 3 *Degrees of Freedom* (DOFs) are necessary (also referred to as Yaw, Pitch, and Roll).

Kinematics: Kinematics focuses on the study of geometry and motion of automated and robotic systems. On the basis of this study, it describes parameters such as position, velocity and acceleration of joints, links and tool center points in order to generate mathematical models creating the basis for controlling the actuators. Manipulators are a kinematic system consisting of a multitude of kinematic subsystems, of which the kinematic pair is the most basic entity.

L

Large Scale Prefabrication (LSP): *Off-site Manufacturing* (OFM) of high-level components, modules or units in a large quantity on a production-line-based and automated factory network, interconnected in an OEM-like integration structure.

Link of a Manipulator: A manipulator consists of at least one kinematic pair, consisting of two rigid bodies (links) interconnected with a joint.

Logistics Systems: Logistics can be defined as the transport of material within manufacturing systems and supply networks. Logistics is a kind of manipulation of an object by human beings, tools, machines, automation systems and robots (or combinations of those), positioning and orientating objects to be transported in a three-dimensional space. However, logistics operations do not change or transform the material directly. Logistics systems can be characterized according to various scales, such as assembly system scale, factory internal scale (*Factory Internal Logistics*, FIL), factory external scale (*Factory External Logistics*, FEL).

M

Mass Customization (MC): MC strategies unify advantages of workshop-like and production-line-based manufacturing, and thus product differentiation-related competitive advantages, with mass-production-like efficiency. On the product side, MC demands that a product unifies customized and standardized elements, for example through modularity, platform strategies and *Frame & Infill* (F&I) strategies in order to be able to efficiently produce it in an industrialized manner. On the manufacturing side, MC demands highly flexible machines, automation systems or robot technology that removes the need for human labor in the customization process, and thus the main drivers for cost and lead times.

Manipulator: System of multiple links and joints that performs a kinematic motion. Depending on the ratio of autonomy and intelligence, embedded manipulators can be machines, automated systems or robots.

Manufacturing: In this thesis, manufacturing refers to systems that produce products. Manufacturing integrates production (parts or low-level component production) and assembly processes.

Manufacturing Lead Time: Total cycle times of workstations in a sequence.

Material Handling, Sorting and Processing Yard (MHSPY): Subsystem of an *Automated/Robotic On-site Factory*; often related to the *Ground Factory* (GF). An MHSPY can be a covered environment or/and can be equipped with *Overhead Manipulators* (OMs) and allows the simplification or automation of the picking up of components from delivering *Factory External Logistics* (FES) in a *Just in Time* (JIT) and *Just in Sequence* (JIS) manner. An MHSPY can also be used to transform parts and low-level components into higher level components on-site. In *Automated/Robotic On-site Factories* used to deconstruct buildings, MHSPYs can be used to transform higher level components into lower level components and parts.

Means of Production: Means of production can be classified into human resources, equipment and material to be transformed.

Modularity: Modularity refers to the decomposition of a structure or system into rather independent sub-entities. It can cover the functional realm as well as the physical realm. If structures or systems are nearly impossible to decompose, both on a functional and a physical level, the artifacts are referred to as “integral”. If systems can clearly be decomposed, both on a functional and a physical level, artifacts are referred to as “modular”. Real modularity is, in construction practice, still a rare phenomenon, and conventional buildings show basic characteristics of integral product structures. Automated/robotic on-site factories, however, require strict modularity.

Module: In a hierarchical modular structure, modules represent elements on a hierarchical level above high-level components. Parts, components and modules can be assembled into *units*, which are ranked higher than modules.

Modular Flexibility: The change in product and strategy exceeds the in-built flexibility and necessitates the exchange of means of production or their rearrangement. Modularity can be generic (predefined process or system modules) or unforeseen (exchange of completely new modules, new configurations).

N

nth, n-1, n-2, n-X floors: Inside the main factory (e.g. a *Sky Factory*, SF) of *Automated/Robotic On-site Factories*, work (component installation, welding, interior finishing, etc.) is done in parallel on several floors (n-floors). The nth floor represents the uppermost floor in which work takes place in parallel and the n-X floors represent the floors below this floor in which work takes place in parallel.

O

OEM-Model: An *Original Equipment Manufacturer* (OEM) relies on suppliers, which, according to their rank in the supplier chain, are called Tier-n suppliers. The model explains the general flow of material as well as the flow of information during development of the product and its sub-components.

OEM-like Integration Structure: Value systems or parts/components integration structures that do not fully follow the OEM-Model, but show characteristics of it.

Off-site Manufacturing (OFM): Components or complete products are manufactured in a structured (factory) environment distant from the final location where it is finally used. Components or complete products can be packed and shipped or are mobile (e.g. car, aircraft).

One-Piece-Flow (OPF): OPF refers to a highly systemized and production-line-based manufacturing system in which each component or product assembled can be different.

On-site Manufacturing (ONM): Products such as buildings, towers, bridges etc. have to be produced on-site at the location at which they are to be finally used - they cannot be moved or shipped as an entity.

Open Sky (OSF): *Sky Factory* (SF) covering and protecting the workspace in *Automated/Robotic On-site Factories*, and, in contrast to *Closed Sky Factories* (CSFs) only allows the installation of a partly *Structured Environment* (SE) that at least (compared to

conventional construction) minimises the influence of parameters that cannot be 100% specified (e.g. rain, wind).

Original Equipment Manufacturer (OEM): Integrates and assembles components and subsystems coming from sub-factories and suppliers to the final product within the *OEM-Model*. Value chains that do not fully follow the *OEM-Model*, but show characteristics of it, are also referred to as *Final Integrators*.

Overhead Manipulators (OMs): OMs operate within off- or on-site factory environments and in *Automated/Robotic On-site Factories* are often the central elements of the *Horizontal Delivery System (HDS)*. On the one hand, OMs (for example gantry type OMs) allow the precise manipulation of components of extreme weights and at high speed, which cannot, for example, be accomplished by currently available anthropomorphic manipulators. On the other hand, OMs require a simplification of the assembly process by *Robot Orientated Design (ROD)* as their workspace and their ability to conduct complex positioning and orientation tasks is limited.

P

Part: In a hierarchical modular structure, parts represent elements on a hierarchical level below components.

Platform Strategy: A platform is a basic framework, a set of standards, procedures or parts or a basic structure that contains core functions of a product. A platform allows for the highly efficient production of customized products, as it allows for the platform to be mass-produced and to wear individual modules on top of it, which can be customized.

Performance Multiplication Effect (PME): PME in this thesis refers to the multiplication of productivity or efficiency within an industry, followed by the introduction of advanced machine systems. Industries such as the farming industry, and tunnel boring and automotive industry have, with the switch from crafts based to machine based manufacturing, not only incrementally improved performance but multiplied it (for example by reducing lead time down to one tenth, reducing required human labor down to one tenth, etc.).

Production: In this thesis, manufacturing refers to the production of parts or low-level components. It includes transformation of raw material into parts. Downstream processes dealing with the joining of elements generated within production are referred to as assembly.

Production Line Organization: In a production line organization, the flow of material between individual workstations is fixed; a material transport system links the stations and the cycle times of the workstations are synchronized.

Productivity: $\text{Productivity} = \text{Output (quantity)} / \text{Input (quantity)}$. Productivity quantitatively expresses an input to output ratio, with a focus on a single (input) means of production or a single (input) factor of production. Productivity indices concerning the type of factor are, for example: work productivity, capital productivity, material productivity, resource productivity and machine productivity.

Pulling Production: Refers to a production system where products are only manufactured on the basis of actual demand or orders. Parts, components and products required are pulled from upstream, according to the actual demand. It might refer to the whole manufacturing system, as well as to individual workstations or groups of workstations. Examples: *Toyota Production System (TPS)*, Sekisui Heim, Toyota Home.

Pushing Production: Refers to the continuous production of elements/products in a certain fixed amount based on predictions or assumptions. Without taking into consideration the actual demand in downstream process steps, parts, components and products are pushed through individual stations. It might refer to the whole manufacturing system or to individual workstations or groups of workstations. Example: Henry Ford's Mass Production.

R

Radio Frequency Identification Tag (RFID): RFID tags are cheap tags that can be attached to components, modules, units or products. RFID-readers can be integrated into floors or placed over gates and can then identify the object passing by. They can be distinguished between simpler and low cost passive tags, and more complex active tags. Advanced readers can read multiple tags at once.

Real-time Economy (RTE): Macroeconomic view of the impact of the multitude of changes our economy, manufacturing technology and the relation between customers and businesses undergo. It targets the fulfillment of customer demands and requests in near real-time. Products and services are processed within a few hours and delivered within days.

Real-time Monitoring & Management System (RTMMS): Data from sensor systems, as well as from the servomotors/encoders of the *Vertical Delivery System (VDS)* and *Horizontal Delivery System (HDS)*, along with information obtained from cameras monitoring all activities (including human activities) in *Automated/Robotic On-site Factories* are used to create a real-time representation of equipment activity and of the construction progress. Furthermore, barcode systems often allow the representation and optimization of the material flow, allowing equipment (such as the automatic lift) to identify the component being processed. In most cases, real-time monitoring and management is done in a fully computerized on-site control center. An RTMMS simplifies progress and quality control, and reduces management complexity.

Re-Customization: Remanufacturing strategy that allows a building to be disassembled and for major components to be refurbished and equipped with new parts on the basis of mechanised or automated manufacturing systems in order to meet changed or new customer demands.

ROD (ROD): ROD is concerned with the co-adaptation of construction products and automated or robotic technology, so that the use of such technology becomes applicable, simpler or more efficient. The concept of ROD was first introduced in 1988 in Japan by Bock, T. and served later as the basis for automated construction and other robot-based construction systems/sites.

Rotation: A term used to describe a kinematic structure. A revolute joint allows an element of a machine or manipulator to rotate around an axis and in a serial kinematic system adds 1 *Degree of Freedom* (DOF) to the system.

S

Selective Compliance Articulated Robot (SCARA): Developed by Yamanashi University in Japan in the 1970s. It combines two revolute and one prismatic joint so that all motion axes are parallel. This configuration and the thus enabled allocation of the actuators are advantageous for the stiffness, repeatability and speed with which the robot can work. Due to its simplicity, the SCARA is also a comparably cheap robot system. It laid the foundation for the efficient and cheap production, and thus the success of Sony's Walkman.

Single-task Construction Robot (STCR): STCRs are systems that support workers in executing one specific construction process or task (such as digging, concrete leveling, concrete smoothing, and painting) or take over the physical activity of human workers that would be necessary to perform this one process or task.

Sky Factory (SF): Structured factory or factory-like environment set up on the construction site as part of *Automated/Robotic On-site Factories*. SFs cover the area where building parts and components are joined to the final product and rise with the upper floor of a building through a *Climbing System* (CS). SFs can enclose and protect the work environment completely (*Closed Sky Factory*, CSF) or only partly (*Open Sky Factory*, OSF).

Slip forming technology: moving or self-moving form that allows casting concrete structures as columns, walls or towers on-site in a systemized manner on the construction site.

Stilts: The *Sky Factories* (SFs) of *Automated/Robotic On-site Factories* often use stilts (made of steel) integrated within the *Climbing System* (CS) to be rested on the building which they are manufacturing. Stilts can be lifted and lowered via the *Climbing System* (CS), thus allowing the *Sky Factory* (SF) to move on top of the building's steel column structure.

Structured Environment (SE): In factories or factory like environments, work tasks, workspaces, assembly directions and many other parameters (e.g. climate, light, temperature, etc.) can be standardized and precisely controlled. The structuring of an environment creates the basis for the efficient use of machines, automation and robot technology.

Superstructure: The concept of dividing a building into superstructure and substructure is an approach which introduces the concept of hierarchies to a building's structure and components and thus can serve as a basis for possible modularization. Goldsmith introduced the idea of making the transmission of forces within high-rise buildings by the superstructure to a clearly visible architectural element in his thesis (1953). A superstructure can serve as a platform or frame that allows customization by further infill.

Supply Chain: the supply chain connects value added steps and transformational processes across the border of individual factories or companies. Its aim is to interconnect all processes and workstations to complete a product informationally and physically, in order to create uninterrupted on-demand or in-stock flow of material.

Sustainability in Manufacturing: Manufacturing systems can be designed to be efficient and to equally meet economic, environmental and social issues. In this thesis, sustainability in manufacturing refers predominately to the ability of a manufacturing system to reduce consumption of resources and the generation of waste.

T

Tier-n supplier: Suppliers are, according to their rank in the supplier chain, called Tier-n suppliers. A tier-1 supplier is a first rank supplier which relies on components from Tier-2 supplier; a Tier-2 supplier relies on components from Tier-3 suppliers and so on.

Tool Center Point (TCP): The End-effector is a tool which is carried by the kinematic system. For each End-effector, a tool TCP is defined as the reference point for kinematic calculations.

Toyota Production System (TPS): The TPS is a logical and consequent advancement of the concept of mass production to a more flexible and adaptive form of demand oriented manufacturing, developed by Toyota between the 1960s and 1970s. From the 1980s, TPS principles gained worldwide recognition and today it forms the conceptual basis for manufacturing systems around the world. Concepts such as *Just in Time* (JIT), *Kaizen*, *Kanban*, *Pulling Production*, failure free production and *One-Piece-Flow* (OPF) have their origins in the TPS.

Technology Diffusion: Technology Diffusion describes the step-by-step spread of a technology throughout industry or as for example computer technology throughout society. In order to simplify the adoption of novel technologies and increase their application scope

over time, novel technologies have to be made cheaper, less complex and split up into individual modular elements. Technology Diffusion therefor often is accompanied by a switch from centralized to rather decentralised applications of the novel technology.

Transformational Process: Any organization and its manufacturing system transform inputs (information, material) into outputs (products, services). The transformation is performed by the organization's structural setting and its means of production, which is a specific combination of workers, machines, material and information.

Translation: A term used to describe a kinematic structure. A prismatic joint allows an element of a machine or manipulator to move in a given trajectory along an axis and, in a serial kinematic system, adds 1 *Degree of Freedom* (DOF) to the system.

Tunnel Boring Machine (TBM): TBMs mechanize and automate repetitive processes in tunnel construction. TBMs are self-moving under-ground factories that more or less automatically perform excavation, removal of excavated material and supply and positioning of precast concrete segments. TBMs are equal in many ways to automated construction sites (and the production of a building's main structure by *Automated/Robotic On-site Factories*).

24/7-mode: The Operation of a factory, processes or equipment without major interruption 24 hours a day, 7 days a week. Requires the work environment to be structured and protected from influencing factors such as weather and the day/night switchover.

U

Unit: Parts, components and modules can be assembled into units, which are higher ranked than modules. Units are completely finished large sized three-dimensional building sections, manufactured off-site.

Unit Method: Sekisui Heim, Toyota Home and Misawa Homes (Hybrid) break down a building into three-dimensional units. Those units are realized on the basis of a three-dimensional steel space frame, which, on the one hand is the bearing (steel) structure of the building, and on the other hand can be placed on a production line where it can be almost fully equipped with technical installations, finishing, kitchens, bathrooms (plumbing units) and appliances.

Upstream/Downstream: Refers to processes or activities in a value chain or manufacturing chain which are conducted before (upstream) or after (downstream) a certain point

Urban Mining: refers to strategies that allowing the city and especially its building stock to be a mine for resources, parts and components. Systemized deconstruction of buildings

under controlled and structured conditions, as in automated construction sites, play a crucial role in urban mining.

V

Vertical Delivery System (VDS): System that transports parts/components on the construction site from the ground (e.g. material handling yard) to the floor level where the components shall be assembled.

W

Workbench-like Organization: the product stays at a fixed station in the factory where it is produced or assembled manually or automatically through the use of various tools. The means of production is organized around this one station.

Workshop-like Organization: In a workshop-like organization, the product and/or its components flow between workstations. The sequence is not fixed and the product has to go through each station to be completed.

Z

“Zero” Waste Factory: A factory that minimizes resource input and waste output and allows all generated waste to be recycled.

List of Figures

Figure 1-1: In the manufacturing industry in general, the integration of products, organization, informational aspects and machine technology is the key for automated product generation and the steady increase of efficiency, product quality and product complexity. Neither product structures (e.g. through modularity, design for manufacturing), nor organizational strategies (e.g. JIT, JIS, Pulling Production) or informational aspects (e.g. CAD/CAM or CIM) could unfold their full potential without the “M”: Manufacturing Technology.....4

Figure 1-2: Functional view: a combination of multiple functions in one complex machine that combines processes to a chain (as e.g. in farming and open cast mining) has not taken place yet in on-site building construction. The picture shows a machine integrating multiple functions in open-cast mining.23

Figure 1-3: Conventional construction in practice: Supervision of unit installation process by four workers (3 operational floors, 1 ground floor) and one tower/mobile crane operator. The installation of the unit took 25 minutes. Cadolto construction site, Augsburg, Picture: Linner24

Figure 1-4: Examples for use of manipulator technology in the Middle Ages.....28

Figure 1-5: use of gantry cranes to position prefabricated three-dimensional space frame units (according to **Ledderboge, 1962**) for the fast on-site completion of condominiums...31

Figure 1-6: First 7-DOF manipulator kinematics for construction purposes by Wachsmann. Scale model built by the Chair for Building Realization and Robotics.32

Figure 1-7: Schematic representation of the on-site fixed type manufacturing process used to construct the BMW-Tower in Munich (according to **Weller, 1986**).33

Figure 1-8: HT1 scale model, retracted (left) and extended (right). Zuse’s first approach concerning the design of an auto-extendable and retractable tower construction (photo courtesy of **Deutsches Museum München**; Picture Numbers: BN_60761, BN_60762)34

Figure 1-9: Gain in flexibility through integration of machine tools with electronics and computer technology (photo courtesy of **Deutsches Museum München**; Raboma Machine Tool, Picture Number: R2121-10; Machining Center Hermle UWF 902 H, Picture Number: CD63624).....36

Figure 1-10: Use of flexible and reprogrammable machining and assembly centers to construct buildings on the construction site37

Figure 2-1: Viewed economically and operationally, factors related to human labor and workforce are, concerning their performance, not 100% definable, predictable and calculable and thus state a certain risk for investment and optimization alike..... 53

Figure 2-2: Labor productivity in industry generally, and especially in the manufacturing industry is continuously rising; labor productivity in construction has been decreasing for decades. (according to **Construction Industry Handbook 2012, Japan**)..... 55

Figure 2-3: Relative weighting of parameters influencing construction tasks on a daily basis - concrete formwork installation (**Moselhi & Kahn, 2012**) 56

Figure 2-4: Raw Material Consumption (short tons) in the United States 1900-1995 (on basis of U.S. Geological Survey Institute, **USGS, 1998**) 58

Figure 2-5: Number and rate of fatal work injuries by industry sector, 2010 (on basis of **U.S. Department of Labor, 2012**) 59

Figure 2-6: Research and Development Investment (in €1,000s per employee in german key industries in comparison (figure according to **Züblin, 2003**) 61

Figure 2-7: Paulson’s graphical analysis of the rising costs when using labor-intensive versus capital-intensive methods in industry (according to **Paulson, 2004**)..... 64

Figure 2-8: Shows a cabinet with removed top plate and sensor infill (system for reading multiple RFID-tags). Each cabinet, and thus its sensor system infill, is connected to the basic wall unit (which also integrates a mini server as “brain”) by a USB connector. USB provides electricity as well as data transfer capability. Connector system developed by the author within LISA..... 68

Figure 2-9: OEM Model. OEMs rely on suppliers which are called Tier-n suppliers, according to their rank in the supplier chain. The model explains the general flow of material as well as the flow of information during development of the product and its sub-components (based on **Kurek, 2004**)..... 78

Figure 2-10: Modular manufacturing segments allow for re-configurability of the Smartville factory on basis of modular flexibility (graphical representation adapted and refined on basis of **Block & Greif, 2007**) 80

Figure 2-11: The number of industrial robots sold per year has been stagnating since 2005 (graphical representation based on graphic presented in **World Robotics Report, 2011**) .. 86

Figure 2-12: Shimizu’s SMART is a modular automated on-site factory with modular robotic (overhead) manipulators and modular exchangeable end-effectors. Apart from the flexibility allowed by modularity, the manipulators and the end-effectors integrate in-built flexibility (for example, through re-programmability) 88

Figure 2-13: While in the manufacturing industry generally, standard industrial manipulators are widely deployed, in the construction industry (due to factors such as component size and weight) more specialized solutions are required.	89
Figure 3-1: Inax assembles customized bath modules on the production line.....	106
Figure 3-2: Analysis of steel unit manufacturing process used by Sekisui Heim.....	109
Figure 4-1: Timeline showing activity of institutions participating actively in the development of STCRs (refined and complemented with own information on basis on basis of Cousineau & Miura, 1998 and 1998; Hasegawa, 1999)	134
Figure 4-2: Integration of Fujita subsystems and STCRs (visualization according to Construction Robot System Catalogue in Japan, 1999, p. 223).....	167
Figure 4-3: Concept for automatic facade lifting, positioning and finishing by Japan Industrial Robot Association (visualization according to Hasegawa, 1999, p. 245).....	167
Figure 4-4: First concepts of a combination of a climbing mechanism with a robotic manipulator, allowing floor-by-floor installation of columns and beams (visualization according to Obayashi, H. Teraoku).....	168
Figure 4-5: Fujita's Arrow Up allowed the subsequent push-up of a steel structure assembled on a ground floor level (visualization according to Construction Robot System Catalogue in Japan, 1999).....	169
Figure 4-6: Super Open Caisson System (SOCS) conducted jointly by 13 companies from the end of the 1980s onwards. The spanning and covering of on-site work by a gantry-type site factory, integrating multiple automatic subsystems, is shown (visualization according to Construction Robot System Catalogue in Japan, 1999).	170
Figure 4-7: Development of method of ROD by Bock, T. from 1985 onwards within WASCOR. Reduction of complexity of assembly process by reduction of parts and redesign of component structure. (visualization according to Bock1988)	172
Figure 4-8: Analysis of positioning process and related kinematics of the installation of a ceiling panel as a basis for automation. Researchers started to develop a construction specific kinematics science and to identify and specify DOFs, robot motions and robot trajectories necessary to install specific parts and components on the construction site. (Picture taken from Hasegawa et al., 1992)	172
Figure 4-9: Multiple cooperating construction robots are operated by a single human supervisor from a central box, Vision Sketch (picture courtesy of Japanese Research Institute, 1980).....	173
Figure 4-10: Multiple robots cooperating in damn construction. Concept by Shimizu (visualisation according to a Shimizu concept study presented on 5th ISARC)	174

Figure 4-11: Integration and cooperation of several robotic systems on the construction site to construct a reinforced concrete based building (visualization according to Hasegawa, 1985)	174
Figure 4-12: Integration and cooperation of several robotic systems on the construction site to construct a building on-site. Concept discussed within WASCOR (picture courtesy of Bock)	175
Figure 4-13: First concept studies for on-site SF and arrangement of OM system “Automatic Building Construction Floor” (visualisation according to Obayashi Research Institute, Teraoku)	176
Figure 4-14: First concept studies for on-site GF and building push-up approach (visualisation according to Fujita, Fukuda)	176
Figure 4-15: First concept studies for Super Construction Factory (SCF) approach. Integration of ground processing yard, VDS and SF and OM to a JIT/JIS component assembly system on-site (visualisation according to Shimizu, Mori)	177
Figure 4-16: Test of fully functioning SMART Prototype on Shimzu’s research testing area, 1988/89 (picture courtesy of Bock)	180
Figure 5-1: Comparison of time needed by different ABCS applications in various projects (Ikeda & Harada, 2006)	345
Figure 5-2: FES for standard floor and with system in full operation (Miyakawa et al., 2000)	345
Figure 5-3: Comparison of unit labor requirements per floor area (Miyakawa et al., 2000)	346
Figure 5-4: Rating of usability of features of sky factory approach. Comparison of rating of various classes of workers compared; a rating of 5 indicates negative opinion, whereas a rating of 1 indicates a positive opinion (Miyakawa et al., 2000)	348
Figure 5-5: Standard schedule (six-day process) (Ikeda & Harada, 2006)	349
Figure 5-6: Shorter schedule (five-day process) (Ikeda & Harada, 2006)	350
Figure 5-7: Comparison of labor requirement per floor area (Ikeda & Harada, 2006)	350
Figure 5-8: Welding Length (Ikeda & Harada, 2006)	351
Figure 5-9: Overall progress schedule and cycle process for a basic floor (Wakisaka et al., 1997)	352
Figure 5-10: FES (Wakisaka et al., 1997)	352

Figure 5-11: Comparison of the cycle time between automatic and manual control systems (Wakisaka et al., 1997).....	354
Figure 5-12: Productivity comparison of four construction methods (Wakisaka et al., 1997).....	355
Figure 5-13: Efficiency comparison between two tower cranes and parallel delivery systems (Wakisaka et al., 1997).....	355
Figure 5-14: Comparison between numbers of laborers (man/floor) regarding the time needed (Wakisaka et al., 1997).....	356
Figure 5-15: Surface temperature of workers' clothes and reinforcement (Wakisaka et al., 1997).....	357
Figure 5-16: Wind flow measurement (Wakisaka et al., 1997)	358
Figure 5-17: Work schedule (Yoshida et al., 1997)	360
Figure 5-18: Cyclic procedure of construction work (Yoshida et al., 1997).....	361
Figure 5-19: Comparison of Automatic/ Manual Conveying Time (graphical representation according to Yoshida et al., 1997)	362
Figure 5-20: Example of automation for construction (construction period comparison) (Sekiguchi et al., 1997).....	364
Figure 5-21: Process cycle for six days (Sekiguchi et al., 1997)	365
Figure 5-22: Construction work production rate comparisons (Sekiguchi et al., 1997)	366
Figure 5-23: Construction work production rate comparisons (Kajima, 2000)	367
Figure 5-24: Time required for installation of various components (Sekiguchi et al., 1997).....	368
Figure 5-25: Overall view of information integration system (Sekiguchi et al., 1997).....	368
Figure 5-26: Shortening of construction period: comparison between conventional and SMART system of construction (Maeda & Miyatake, 1997; Maeda, 1994)	369
Figure 5-27: Five-and-a-half day FES process (Maeda & Miyatake, 1997; Maeda, 1994).....	369
Figure 5-28: Five-day FES process (Maeda & Miyatake, 1997; Maeda, 1994).....	370
Figure 5-29: Conveying by conventional tower crane (Maeda & Miyatake, 1997; Maeda, 1994).....	370
Figure 5-30: SMART conveying strategy (Maeda & Miyatake, 1997; Maeda, 1994)	370

Figure 5-31: Reduction of man hours related to the construction of a standard floor manufactured by the system in full operation (Maeda & Miyatake, 1997; Maeda, 1994)	.372
Figure 5-32: Reduction of man hours related to the whole on-site construction work, from ground level onwards (Maeda & Miyatake, 1997; Maeda, 1994) 372
Figure 5-33: (left) Improvement of transportation and Installation time of members. (right) Improvement of the number of transportation (Maeda & Miyatake, 1997; Maeda, 1994)	373
Figure 5-34: Reduction of construction waste (Maeda & Miyatake, 1997; Maeda, 1994)	373
Figure 5-35: Generation of transportation paths and collision avoidance (Maeda & Miyatake, 1997; Maeda, 1994) 374
Figure 5-36: Overall work process chart (Morita et al., 1993; Fujii et al., 1995) 375
Figure 5-37: Overall work process chart (Morita et al., 1993; Fujii et al., 1995) 377
Figure 5-38: Basic construction procedure (Council for Construction Robot Research, 1999) 378
Figure 5-39: FES (Itou et al., 1994) 379
Figure 5-40: Time necessary for transporting and assembling structure (min/floor) (Itou et al., 2000) 380
Figure 5-41: Construction schedule for model building (Sakamoto & Kumano, 1991) 381
Figure 5-42: Construction process by a OM (Sakamoto & Kumano, 1991) 381
Figure 5-43: Labor productivity (Sakamoto & Kumano, 1991) 382
Figure 5-44: Construction time reduction (Sakamoto & Kumano, 1991) 382
Figure 5-45: Reduction in time for removing the welding machines (Sakamoto & Kumano, 1991) 383
Figure 6-1: General concept for target system - uninterrupted and production-line-like material flow on-site, easement of any idle time/down time on-site 394
Figure 6-2: Today's general module-supply structure in conventional construction represented in an abstract way 402
Figure 6-3: Module-supply structure of the developed and realized automated construction sites to date 402
Figure 6-4: Ideal module-supply structure suggested for target system (based on Bock, 1988) 402

Figure 6-5: Examples of buildings with superstructures	409
Figure 6-6: station for loading large sized units onto special transport trucks. Cadolto, 2011. (Picture Source: Linner)	412
Figure 6-7: Analysis of various measurement unit systems. Right: container measurement system. Bottom: current building units measurement system, Top: BMU	413
Figure 6-8: Mobile naval BMU manufacturing and delivering systems. Conversion of an aircraft carrier to a mobile naval BMU manufacturing and delivering system that is informationally directly integrated with the GF (Linner et al., 2010). Manufacturing takes place under the flight deck. Delivery of units to land or the site is possible via smaller transport ships and via helicopters or cargo airships.	414
Figure 6-9: Visualization of evolution scheme of the system proposed by Approach 5 (for further details see <i>A0 plan "Approach to real-time and building-integrated automated Construction"</i>)	415
Figure 6-10: idea of (visible) multiple/bundled tubes (Sears Tower, John Hancock Building)	425
Figure 6-11: ROD related to functional aspects. Efficient application of maintenance robots requires buildings to be designed taking into account the robot's specifications.....	442
Figure 6-12: Reduction of organizational complexity. Left: A Korean facade installation robot requires three workers to be operated and does thus not fulfill the requirements to reduce organizational complexity (picture courtesy of Lee, see also Lee, 2008). Right: ABCS uses connectors in combination with a robotic overhead crane, reducing the number of workers to only one worker supervising many parallel activities at once, and the need for assisting workers guiding the component has been completely removed (graphical representation according to Obayashi, 1993)	448
Figure 6-13: Reduction of gripper-/end-effector complexity. Left: A standard concrete element is enclosed by a heavy and powerful pincer-like gripper. Right: The gripper impales the concrete element, designed in accordance with ROD principles, resulting in gripper-/end-effector complexity.	450
Figure 6-14: Reduction of gripper-/end-effector complexity. The SMAS gripper compared to the ROCCO gripper shows lower kinematic and sensor, process measuring and control complexity. Left: SMAS, a specially designed stone allows the gripper to impale the redesigned stone and screw it onto the stone below. Right: The handling of a gripper of a standard and non-redesigned stone results in higher complexity of the gripper system.	451
Figure 6-15: Approach for the integration of building structure, construction technology and building design. (Graphical representation according to Bock and Centre Nationale de Recherches et Sciences/First National Committee Robotique en BTP, Paris, 1989).....	454

Figure 6-16: Complexity reduction along the value chain. In automation and robotics in construction, which sees the building to be created as a product, complexity is subsequently reduced along various steps in the value chain. We distinguish between pure production (usually an off-site process), prefabrication/pre-assembly (usually an off-site process) and on-site automation. 456

Figure 6-17: Complexity reduction through use of components on automated construction sites. Left: Prefabricated concrete component optimized for handling by robot. Right: rail-guided robot picking and positioning concrete elements..... 459

Figure 7-1: Left: female worker on the construction site remote controlling and supervising the operation of ABCS subsystems. Right: Worker in control room supervising processes and construction progress. 474

Figure 7-2: Classification of innovation generation frameworks developed within general (not construction specific) innovation science..... 480

Figure 7-3: 7-DCI Diagram (Dimension Construction Innovation Diagram)..... 488

Figure 7-4: Closed Loop Manufacturing: material or product flows at a factory level (BCM, LSP, and Automated/Robotic On-site Factories), utilization level and deconstruction level could be related back to the manufacturing system in order to close the loop. (Adapted and advanced on basis of **Steinhilper, 2007**). 508

Figure 7-5: Framework for the integration of automation and robot based manufacturing technology over the life cycle of buildings..... 510

Figure 8-1: Relation between improvement of production processes and enhanced product performance..... 519

List of Tables

Table 1-1: Modular building component systems and modular building structures, literature review	8
Table 1-2: “Computer aided” systems and software tools can assist in every life-cycle phase.....	16
Table 1-3: Historical view: Development of conventional and frequently used building construction on-site equipment.	23
Table 1-4: Evolution from machine elements to complex kinematic structures and finally to systemic mathematic analysis and synthesis methods, leading to modern robot control (fusion of information obtained from Ferguson, 1962; Laurenza et al., 2005; Moon, 2007; Galluzzi, 1996)	26
Table 2-1: Parameters determining productivity, efficiency and economic performance.	52
Table 2-2: The significantly low capital stock and capital intensity, when compared to other industries, is clear (Table on basis of Institut der deutschen Wirtschaft in Köln, 2012).....	62
Table 2-3: Comparison of characteristics of conventional and modular buildings.....	66
Table 2-4: Relation of hierarchical level, changeability class, manufacturing level, product level and time horizon (own interpretation on basis of EIMaraghy & Wiendahl, 2009	70
Table 3-1: Analysis framework BCM (concrete, brickwork, steel, wood).....	98
Table 3-2: Performance of Japanese LSP industry in 2011.....	102
Table 3-3: Comparison of manufacturing systems (final assembly stage) used to build complex products consisting of more than 10,000 parts.	122
Table 3-4: Switch of major industries from traditional crafts based to machine based manufacturing and improvement of production speed and labor productivity.....	129
Table 5-1: Framework defining parameters for technical analysis of integrated Automated/Robotic On-site Factories	184
Table 5-2: Efficiency analysis framework.....	342
Table 5-3: Specifications of parallel delivery system (Table according to Wakisaka et al, 1997).....	353

Table 5-4: OM specification (Yoshida et al., 1997).....	362
Table 5-5: Labor-saving result (Table according to Yoshida et al., 1997).....	363
Table 5-6: Specification of Z-Up, Z-Hand and Z-Carry (Hasegawa, 1999)	365
Table 5-7: Comparison of Yokohama project with Nagoya project (Maeda & Miyatake, 1997; Maeda, 1994).....	371
Table 5-8: Simulation for roof pushing construction chart to optimize performance cross all steps (graphical representation according to Morita et al. 1993; Fujii et al., 1995)	376
Table 5-9: Construction Capacity (Itou et al., 1994)	380
Table 6-1: Use of sensor systems to assist automated building manufacturing in various life-cycle phases.	418
Table 6-2: Available sensor technology,.....	420
Table 6-3: Weighting Criteria Value Analysis (Scoring-Model)	427
Table 6-4: Relation of Design for X (DfX) and Robot Oriented Design (ROD).....	434
Table 7-1: Strategy/Technology Field Modularity. Identification of strategies and technologies compatible with the approach to real-time and building integrated manufacturing, detailing of their potential and identification of innovation and technology management methods that can be used to support their integration.	489
Table 7-2: Strategy/Technology Filed Technology and Organization in Manufacturing. Identification of strategies and technologies compatible with the approach to real-time and building integrated manufacturing, detailing of their potential and identification of innovation and technology management methods that can be used to support their integration.	491
Table 7-3: Strategy/Technology Field Automation and Robot Technology. Identification of strategies and technologies compatible with the approach of real-time and building-integrated manufacturing, detailing their potential and identification of innovation and technology management methods that can be used to support their integration.	494

1 Background, Research Question, Research Method

In this chapter, firstly the background and motivation for this thesis, and the – in the view of the author – urgently needed focus on automation and robot technology based ONM technology in the construction industry is set out. It will be shown that neither current developments in construction in the field of product structures (for example through modularity, design for manufacturing), nor organizational strategies (such as JIT, JIS, Pulling Production) or informational aspects (such as CAD/CAM or CIM) are slowed down or even prevented through the lack of an technologically adequate and integrating manufacturing technology for the construction site. To explain this in detail, the role of complementarity of products, organization, information and machine technology is explained (see **1.1**) and for each field the current state of technological development is reviewed (see **1.2-1.5**).

Secondly, the research question is set out and focused on the possibility to encounter the identified lack of manufacturing technology by installing automatic and/or robotic machining or assembly centers (hereinafter called Automated/Robotic On-site Factories) on the construction site, and turning the construction site into a factory-like, structured manufacturing environment (see **1.6**). Automated/Robotic On-site Factories represent computer controllable and flexible manufacturing technology that erases the necessity for back and forth conversion from digital into analog information on-site and is able to integrate and unfold the potential of advancing product structures, organization and informational aspects. In construction, forms of integrated computer aided support, such as CIM, or more advanced forms such as machine system based industrialized customization, are currently not realizable due to the labor based and low-tech nature of the construction process. The approach presented and discussed in this thesis intends to build a scientific basis for the development of on-site factories that would represent an adequate solution for introducing the missing “M” (Manufacturing Technology) on construction sites.

Thirdly, based on the research question and based on the knowledge and experience the author has gained in nearly six years in research, during which he contributed to a series of research projects covering all of the above mentioned fields (automated manufacturing, advanced product structures, organization and management, informational aspects), a variety of hypotheses were formulated (see **1.6**). The author assumes that structured on-site environments outperform stand-alone technological solutions, such as BCM, LSP or STCR technology, can be designed to automatically manufacture nearly all building topologies, and can be advanced to set up a construction industry which can deliver products in a near real-time manner. The author also assumes that the novel ONM technology – the more radical solutions – require drastic and co-adapted change of manufacturing, technology, organization, products and associated business models in construction. Although the necessary changes and resources are enormous, they can be accomplished on basis of so far developed technologies and that the overcoming of the associated challenges might

eventually be able to turn the construction industry into an incubator for future manufacturing technology.

Finally, in this chapter, the research method is described and the structure of the thesis representing the relevant research steps is outlined (see **1.7**). In order to find answers to the search for a novel ONM technology, and in order to be able to discuss the stated hypotheses, related terms and concepts have been introduced and analyzed, the development in off-site BCM and LSP, as well in other industries manufacturing complex products were mapped and existing approaches to STCRs and Automated/Robotic On-site Factories systematically mapped and analyzed qualitatively and quantitatively. Furthermore, based on the identification of strengths and weaknesses of the analyzed approaches in an exploratory study, novel possibilities for the deployment of on-site factory environments have been tested. A reference for the explanatory study was the concrete plan of a major Korean company (with which the research institute of the author is in contact) to construct its company headquarter with more than 100 floors in Seoul by automated on-site technology and at a speed of about one storey per day. The approach developed for that purpose shall later be used all over Korea (which has a huge demand for high rise buildings) as well as in Japan where, as a result of the Tohoku earthquake, all major high-rise buildings will have to be deconstructed and constructed over the next decade, while causing minimal building downtime. Based on the analysis, categorization and explanatory study, the principles for ROD have been taken forward, and methods and approaches have been suggested for an R&D strategy that would allow the realization of the suggested manufacturing technology.

1.1 The Role of Complementarity of Products, Organization, Information and Machine Technology

In the manufacturing industry in general, the integration of products, organization, informational aspects and machine technology is the key to automated product generation and the steady increase of efficiency, product quality and product complexity. The strong relation between those factors is analyzed in detail later in this thesis (in particular, see **2.1**, **2.2**, **2.3**, and **2.4**). The integration of these factors is also the basis for the customization, or personalization, of products on the basis of automated manufacturing systems and by means of product modularity (e.g. integrated user and producer kits), organizational set-ups and computer aided closed informational chains. It can create systems that link demand and the customer more or less directly (and without the need to convert digital into analog/manual instructions and back) to the manufacturing machines that actually generate the product. Machine technology plays a central role in the constellation described, as major parts of the transformation of inputs to outputs are realized today in a systemic, fast, cost-efficient and high quality manner through machine technology.

Unlike human labor, machine technology (and with it its modern variants such as automation and robot technology) is a calculable means of production that guarantees time, cost and quality, and that naturally, unlike the human being, is potentially unlimited in terms of capacity and capacity improvement. Automation and robot technology, due to programmability, inbuilt flexibility and modular approaches can be adjusted (or can adjust itself) to product variations and even completely different products to be manufactured within short and long-term time frames (see **2.2**). Thus from a technical point of view, concepts such as MC of complex products can be realized today. Furthermore, step by step products, organizational systems and informational aspects are adapted to the novel possibilities created by the advance of machine technology (see **2.3**) and the applicability and efficiency of those concepts is enhanced.

In the construction industry, however, there has been no considerable and steady increase in efficiency and related parameters (productivity, quality, cost and time benefits, greater economic benefits). This is in addition to the lack of an establishment of building manufacturing systems that deliver customized buildings (which, from a manufacturing point of view, are the equivalent of highly complex and large scale “products”) on the basis of highly industrialized and complete (on- and off-site combined) automated manufacturing systems. Those advanced manufacturing systems haven’t been deployable in the construction industry, as the necessary machine technology hasn’t been in existence. Usually when manufacturing industry products, organizational systems, informational aspects (software tools) and machine technology co-evolve (see for example **Baldwin & Clark, 2000; Fujimoto, 1999**). In this chapter it will be shown that in construction industry planning tools, products, and organizational structures have been brought to an advanced state (“advanced” meaning an acceptable state, of course in many aspects it is not as advanced as the general manufacturing industry, but it is at least in some aspects

comparable) over the last few decades, whereas the development and implementation of machine technology has been neglected since the 1980s (especially in Europe and the US).

The use of technology and machines on the construction site - the final assembly place for all buildings – has decreased since the 1980s, while the use of human labor has increased and has tightened the labor-based characteristic of the construction industry. Interestingly it can also be shown that since the 1980s the labor productivity of major construction industries worldwide has decreased (for a detailed examination of labor productivity in construction, see 2.1). In the manufacturing industry, however, productivity in the same time period increased several times over, allowing manufacturing costs (and thus end prices for customers) and manufacturing times (relevant for availability of products and high value for the customer) to be lowered and at the same time for complexity, quality and strategies to deliver individual, customized products to be developed and implemented.

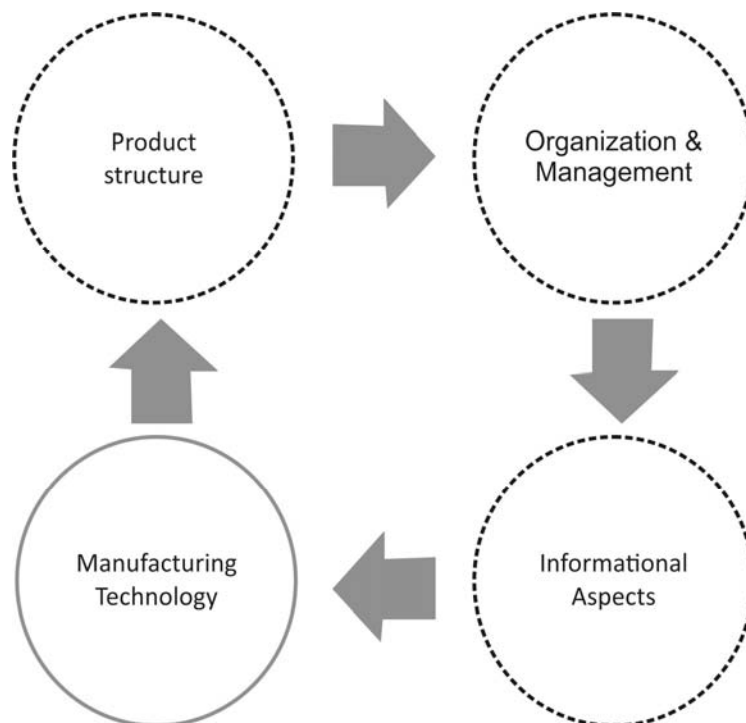

Figure 1-1: In the manufacturing industry in general, the integration of products, organization, informational aspects and machine technology is the key for automated product generation and the steady increase of efficiency, product quality and product complexity. Neither product structures (e.g. through modularity, design for manufacturing), nor organizational strategies (e.g. JIT, JIS, Pulling Production) or informational aspects (e.g. CAD/CAM or CIM) could unfold their full potential without the “M”: Manufacturing Technology.

Neither product structures (for example through modularity, design for manufacturing), nor organizational strategies (such as JIT, JIS, Pulling Production) or informational aspects

(such as CAD/CAM or CIM) could unfold their full potential without the “M”: Manufacturing Technology. According to Piller (2006), other industries have already made similar mistakes (for example the automobile industry with GM and Opel) in the past. In the 1980s, for example, major car manufacturers in the United States invested heavily in the newest manufacturing technology but at the same time did not change products and organizational forms, resulting in major losses in the following decades. Milgrom & Roberts (1990) described this phenomenon with the theory of complementarities, which sees products, organization, informational aspects, manufacturing technology and other aspects related to the generation of a product as a total system: major improvement or major underdevelopment in one entity of the system would make the system more complicated and less efficient. Other business or managerial strategies are targeting a similar direction today, for example as strategies for dynamic adaptation (see for example Cusumano, 2010) and complementary adjustment (see for example Tidd & Bessant, 2010) of the sub-entities of an enterprise or a firm. It is not solely the advance of an individual aspect that is important, but the steady and co-adapted advance of all aspects related to the creation, manufacturing and delivery of a complex product.

Interestingly, major Japanese companies have emphasized since the 1960s that the above described co-adaptation of all product generation processes, such as through a “Poka Yoke” (a design that permits wrong assembly), “Pull Strategies” (the customer and market initiates the manufacturing process) and “*Ringi Seido*” (feedback of information from manufacturing into management). The importance of co-adaptation by modularity and its potential in the general manufacturing industry is analyzed in detail in **chapter 2** (in particular, see **2.2**). Furthermore, the importance of the fusion of products and manufacturing systems to a complementary entity was analyzed by the author of this thesis, in (Bock et al., 2012). The current state of conceptual and technological development in the construction industry for the following fields will now be discussed, the relevant literature reviewed and the relations and interdependencies between the fields shown:

1. Product Structures
2. Organization & Management
3. Informational Aspects
4. **Manufacturing Technology (focus of this work)**

Firstly, the general function of each field will be identified, as well as its role, use and state of the art development in the general manufacturing industry. Then, for the product structure, organization and informational aspects fields, it will be shown how a lack or underdevelopment of machine technology impacts on the interdependencies and prevents efficiency and unleashing of the true potential of the involved fields. Afterwards, the state of the art in construction for each field including relevant development will be reviewed in detail. It will be seen that compared to the other 3 fields, manufacturing technology for on-site final assembly has been underdeveloped, preventing development and efficiency in or by those fields. The identification of the weakness of on-site “M” (manufacturing technology) provided the basis for the development of the focus of this work and the set-up of research question, hypotheses and the research method.

1.2 Current State of Product Structures in Construction

The product structure synchronizes user demands with producer demands and controls the ability to process and change the product throughout all life phases from planning, to manufacturing and use (for an examination of the role of modularity in this context, see **2.2**). In the manufacturing industry generally, a significant role of the product structure (over platform modularity, for example) is to allow systemized or automated manufacturing despite flexibility and product individuality issues. The growing importance of strategies such as DFP and ROD emphasizes the necessity of adapting the product structure to the manufacturing system and technology. Furthermore, today's software tools assist with the adjustment of the modular structure and the assignment of modules, for example, to manufacturing cells as well as the sequencing of the manufacturing process (for an analysis, see **1.4**).

As early as in the 1970s, the modular design of the Sony Walkman was optimized for assembly with a (at that time newly developed) robotic manipulator called SCARA, and thus became the first cheap and thus highly demanded portable music player (discussed in more detail in **6.2.4**). Also, the highly efficient manufacturing of the Ford Model T by Henry Ford can be seen as both an invention in the field of modular structures as well as in the field of manufacturing organization and technology (see **2.3**). The challenge for the designer and engineers involved in the planning stage is to fully synchronize manufacturing demands with design and functional aspects of modular designs. Modular structures require know-how and resources to be built up. Modular structures that are not explicitly used to support the manufacturing process and the use of advanced machine technology – through which input is actually transformed into output – lack a major component for the achievement of efficiency, productivity and economic performance, as they do not make full use of the potential of modularity.

The reviewed literature and current state of development in construction shows that the modular building component systems and modular building structures that have been developed are in tune with architectural aspects, off-site prefabrication processes and transportation/logistics requirements (*Table 1-1*). However, a synchronization of product modularity with on-site-manufacturing-like and machine-based manufacturing systems, in the conventional, non-Japanese and real world construction industry has not been practiced yet. On the construction site (compared to other industries or factory environments) simple organizational structures and simple mechanical and human controlled multipurpose equipment is used which requires no adjustment of the product. As will later be shown, however, those human labor-based manufacturing systems are subject to natural limitations.

Table 1-1: Modular building component systems and modular building structures, literature review

1	Containers and temporary architecture
	Slawik, H.; Bergmann, J.; Buchmeier, M.; Tinney, S. (2010) 'Container Atlas – a practical Guide to Container Architecture'. Berlin: Die Gestalten Verlag
	Klanten, R.; Feireiss, L. (2007) 'Space Craft – Fleeting Architecture and Hideouts'. Berlin: Die Gestalten Verlag
2	Industrialized concrete panel construction
	Heroldt, G. (1962) 'Plattenbauweise – industrieller Wohnungsbau'. Berlin: VEB Verlag für Bauwesen
	Kress, S.; Hirschfelder, G. (1979) 'Industrieller Wohnungsbau'. Berlin: VEB Verlag für Bauwesen
3	Building with reinforced concrete components
	Mokk, L. (1960) 'Bauen mit Stahlbetonfertigteilen- Hallen und Industriebauten'. Berlin/Budapest: VEB Verlag für Bauwesen Berlin/Ungarischer Verlag für Technik
	Mokk, L.; Löke, E. (1973) 'Montagebau in Stahlbeton – Industriebau 1: Konstruktion, Vorfertigung, Montage; Gesellschaftsbau'. Berlin/Budapest: Verlag für Bauwesen Berlin/Verlag der Ungarischen Akademie für Wissenschaften
	Mokk, L. (1968) 'Montagebau in Stahlbeton – Industriebau 2: Internationale Beispiele'. Berlin/Budapest: Verlag für Bauwesen Berlin/Verlag der Ungarischen Akademie für Wissenschaften
	Girmscheid, G. (2010) 'Off-site Production methods – Precast Plant Production'. In Girmscheid, G.; Scheublin, F. (2010) <i>New Perspective in Industrialization in Construction – A State-of-the-Art Report</i> ; CIB Publication 329. Switzerland/Zurich: ETH Zürich, pp. 207-231
4	Building with steel components
	Luig, G. T.; Lenze, V. (1998) 'Stahl im Wohnungsbau'. Berlin: Ernst & Sohn
5	Industrialized construction
	Kotulla, B.; Gropp, M. (1994) 'Industrielles Bauen- Bauwerke'. Renningen-Malmsheim: Expert Verlag
	Kotulla, B.; Gropp, M. (1987) 'Industrielles Bauen- Fertigteile'. Renningen-Malmsheim: Expert Verlag
	Kotulla, B.; Urlau-Clever, B.-T.; Kotulla, P. (1984) 'Industrielles Bauen- Grundlagen'. Düsseldorf: Werner-Verlag
	Weller, K. (1986) 'Industrielles Bauen 1'. Stuttgart: Verlag W. Kohlhammer
	Weller, K. (1989) 'Industrielles Bauen 2'. Stuttgart: Verlag W. Kohlhammer
	Wachsmann, K. (1989/Reprint des Originals von 1959) 'Wendepunkte im Bauen'. Dresden: Verlag

der Kunst

6 Building with systems

Ehrenkrantz, E. D. (1989) 'Architectural Systems – A Needs, Resources, and Design Approach'. New York: McGraw-Hill Publishing

Schmid, G.; Testa, C. (1969) 'Systems Buildings'. Zürich: Les Editions d'Architecture

Staib, G.; Dörrhöfer, A.; Rosenthal, M. (2008) 'Elemente + Systeme - Modulares Bauen: Entwurf, Konstruktion, Neue Technologien.' München: Edition Detail

Schittich, C. (2012) 'Vorfertigung', *Detail Zeitschrift für Architektur*, 20-6. München: Institut für Internationale Architekturdokumentation

7 Building with prefabricated components

Koncz, T. (1966) 'Handbuch der Fertigteilm Bauweise – Grundlagen, Dach und Deckenelemente, Wandtafeln'. Wiesbaden: Bauverlag

Koncz, T. (1967) 'Handbuch der Fertigteilm Bauweise – Hallen und Flachbauten, Wandtafeln'. Wiesbaden: Bauverlag

Koncz, T. (1970) 'Handbuch der Fertigteilm Bauweise – Mehrgeschossbauten der Industrie und Verwaltung, Schul- und Universitätsbauten'. München: Bauverlag

8 Industrialized buildings (with focus on design, architectural and societal aspects)

Bergdoll, B.; Christensen, P. (2008) 'Home Delivery – Fabricating the modern Dwelling', Exhibition Catalogue MOMA. New York, Basel/ Boston/ Berlin: Birkhäuser.

Center de Creation Industrielle (1983) 'Architecture et Industrie Passe et Avenir d'un Mariage de Raison. Exhibition Catalogue'. Paris: Center Georges Pompidou

Matsukuma, H., Inada, T., Yuzuhana, A., Tani, T. Matsuzawa, H., Ichida, T. (2006) 'Kuino Mayekawa Retrospective', [Exhibition Catalogue].Tokyo: The Japan Institute of Architecture

Maier, O. (2010) 'Konrad Wachsmann und Fritz Haller'. In Nerdinger, W. (2010) *Wendepunkte im Bauen*. München: Edition Detail

Nerdinger, W.; et al. (2010) 'Wendepunkte im Bauen', [Exhibition Catalogue]. München: Edition Detail

Powell, K. (2001) 'Richard Rogers – Complete Works, Volume 2'. New York: Phaidon Press Limited

9 Industrialized components and joining systems

Meijs, M.; Knaack, U. (2009) 'Bauteile und Verbindungen – Prinzipien der Konstruktion'. Basel: Birkhäuser

10 Prefabrication and sustainability

Shimizu, N. (2005) 'A House of Sustainability: PAPI - Intelligent House in the Age of Ubiquitous

Computing', Architecture and Urbanism (AU), Special Issue

Wimmer, R. (2009) 'Strategieentwicklung für eine industrielle Serienfertigung ökologischer Passivhäuser, Bericht aus Energie und Umweltforschung'. Wien: Bundesministerium für Verkehr, Innovation und Technologie.

11 Prefabrication and business aspects

Johnson, W. (2008) 'Lessons from Japan: A comparative study of the market drivers for prefabrication in Japanese and UK private housing development', [Master's thesis]. London: University College London

Musso, F. (2010) 'Wendepunkt und Wirtschaft'. In Nerdinger, W. (2010) *Wendepunkte im Bauen*. München: Edition Detail

12 Open and changeable buildings

Steger, B. (2007) 'Vom Bauen – zu Leben und Werk von Ottokar Uhl'. Wien: Löcker Verlag

Beyeler, T. (1988) 'Fritz Haller - bauen und forschen: Dokumentation d. Ausstellung / Kunstverein Solothurn im Kunstmuseum Solothurn'. Solothurn: Kunstverein Solothurn.

Habraken, N. J.; Boekholt, J. T.; Thijssen, A. P.; Dinjens, J. M. (1981) 'Variations – The Systematic Design of Supports'. Cambridge, Mass.: Laboratory of Architecture and Planning at MIT

Habraken, N. J. (2000) 'The Structure of the Ordinary – Form and Control in the Built Environment'. Cambridge, Mass.: The MIT Press

Kendall, S.; Teicher, J. (2000) 'Residential Open Building'. London: E & FN Spon for International Council for Building Research (CIB)

Larson, K.; Intille, S.; McLeish, T. J.; Beaudin, J.; Williams, R. E. (2004) 'Open Source Building – Reinventing Places of Living', *Building Technology Journal*, Vol. 22, 4: 87-200

Georgoulas, C.; Linner, T.; Kasatkin, A.; Bock, T. (2012) 'An Aml Environment Implementation: Embedding TurtleBot into a novel Robotic Service Wall', Proceedings of *7th German Conference on Robotics*. Munich (Germany), VDE Verlag

13 Futuristic concepts for industrialized buildings/architecture

Yatsuka, H.; Kikuchi, M.; Yoshiuki, Y.; and others (2011) 'Metabolism – The City of the Future'. Tokyo: Mori Art Museum & Shinken-chiku-sha

Klotz, H. (1986) 'Vision der Moderne – Das Konstruktionsprinzip'. Frankfurt: Deutsches Architekturmuseum

Cook, P. (1999) 'Archigram' Tokyo: Kajima Institute Publishing

1.3 Current State of Organization and Management in Construction

The main purpose of organization and management is to generate and control the interplay of the means of production (material, machines, and humans) during the transformation of inputs to outputs. The scientific view on manufacturing organization was introduced by Taylor's scientific management (**Taylor, 1911**, *The Principles of Scientific Management*) which started to systemize human work and synchronize it with machine systems. The structuring of work environments and the precise prediction and control of the work processes taking place in it are today the basis for highly efficient (both standardized and flexible) automated manufacturing systems. The PME in major industries (for further explanation, see **3.3.6**) is not only the reason for the evolution of machine technology, but also the co-evolution and development behind organizational ideas and strategies. In today's manufacturing industry in general, the focus is on the organization and management of enterprises around high-tech machine systems (for a detailed analysis of this topic, see **3.3**). Human work activity becomes a part of those machine systems and is used once flexibility is demanded which cannot be achieved by machines.

Due to the rising complexity of products, the quality and high speeds required, machine systems tend to supplement human workforce, even when workers are cheaply available. Long-term, organizational strategies aim at the self-organization of machine systems (cellular logistics, cognitive factories; see also **2.4**) and the banishing of human work activity from the manufacturing shop-floor in production and assembly. The organizational tendencies mentioned above, as well as the increasingly common switch to pulling organization, JIT and JIS, require a highly reliable and computerized manufacturing system from an organizational and management point of view. The lack or underdevelopment of machine technology means that organizational forms that allow the manufacturing of highly complex products efficiently, and thus to a reasonable cost, cannot be realized. Both organization and management would then have to focus rather on the problems arising from the fact that human work activity is not 100% calculable in terms of time, cost, quality and speed (presented in more detail in **2.1**).

The reviewed literature and the current state of development show that construction management (on-site) focuses on the "analogous" organization and management of human-labor-centered on-site construction activity (see for example **Nagel, 1998; Greiner et al., 2002; Gould & Joyce, 2008; Ahrens et al., 2010**). Interestingly, the manufacturing of buildings is still described as a project (e.g. project management in **Fewings (2012)**, amongst others) rather than as a repetitively and flexibly applied system. Furthermore, job site installation on the construction site is a neglected field and only a few researchers and practitioners are concerned with it in any event (see for example **Schach et al., 2011; König, 2011**), and the presented cases, strategies and tools build mainly on the organization and coordination of conventional, analog and low-tech construction machines such as tower cranes and bucket excavators. In Europe and the USA, the use of intelligent

and networkable construction machines (see for example **Frantzen et. al, 2010; Kirchbach et al., 2012; Cheng & Teizer, 2011**) or the use of RFID to control material flow and organization on the construction site (see for example **Helmus, 2010**) exists in research or in prototypes but are far away from market acceptance and deployment. Due to the analog and human labor based on-site construction processes, a real-time monitoring or precise prediction of the actual manufacturing on-site is not possible, which leads to:

1. Complex acceptance procedures (see for example **Hankammer, 2007**)
2. The development of complex, expensive and (still) error prone technology to measure the construction progress (see for example **Adan et al., 2011**)
3. Data acquisition technology that allows the converting of the actual construction product (created by analog machines and human labor) back into data, and models that allow comparison with the intended product (**Son & Kim, 2010**)

The need for a digital construction site has been identified (see for example **Günthner, 2011**), however, the machine technology necessary for its realization is missing. The labor centered organizational nature of the construction process also explains the thriving of new sciences during the last decade, as for example construction controlling (see for example **Leimböck et al., 2007**) and claim management (see for example **Plum & Dornbusch, 2012**) and the growing importance of lawyers and construction law knowledge.

Furthermore, due to the labor based nature of the construction process, the defect costs are enormous (for a more detailed review of defect cost, see **2.1**). In Germany, construction defects account for up to 3% of the investment volume in new construction and more than 3% of the investment in renovation. DEKRA has calculated and estimated defect costs in Germany to be about 2.8 billion euros plus associated costs, meaning that the total cost caused by defects is much higher (up to approximately €5 billion). DEKRA also points out that numerically from 2002, construction defects rose by more than 100%.

Despite the above-mentioned organizational deficits, research and development investment in the construction industry is among the lowest compared with other industries. On average, German construction companies, for example, only spend €590 per employee for R&D per annum compared to the €30,290 per employee spent by the aircraft and space industry (**for further details, see 2.1**). The situation in Germany concerning defect cost and low R&D spending reflects the situation on the international level (see for example **Construction Industry Handbook Japan, 2004, 2010 & 2012**).

All in all, the labor based nature of the on-site construction process represents a major risk for builders and developers (see for example **Lutz & Klapproth, 2003**). The rise of the percentage of cheap and unskilled labor worldwide, as well as the exposure of the on-site workforce to an unstructured, weather affected, and in terms of ergonomics, physically strenuous, hazardous, inappropriate work environment influences not only input factors and productivity but also quality (discussed in more detail in **2.1**). On the basis of the labor-based nature of the on-site construction process, the introduction of state of the art organizational strategies to the manufacturing industry as a whole (such as JIT and JIS,

pulling methods, cellular/self-organization) is not possible, as those require the precision, speed and computational capability of state of the art machine technology. Organizational concepts, such as lean construction (as promoted, for example, by the International Group for Lean Construction; Lean Construction Institute; European Group for Lean Construction) are not in tune with human labor activity and without a co-evolved machine technology are not efficiently deployable.

1.4 Informational Aspects in Construction

One of the main purposes of the informational and computational technology in the professional field today is the fast, cheap and automatic processing of information in and across (all) phases of the generation of products and services.

In the manufacturing industry in general, a major role of the computer is the control of manufacturing systems, including the involved means of production (material flow, machine systems and labor). In highly efficient manufacturing industries a further focus of the computer is on the control of machines and machine systems, rather than on the control of human activities. Even in highly flexible manufacturing as in the case of Dell and the VW Phaeton, where humans flexibly assemble individual end products, the automated logistics and delivery machine technology in the background is the key element (see also **2.3** and **2.4**). By computer controlled machine technology, information can be repetitively embedded into standardized and individual products. A lack of machine technology that can be computer controlled would prevent the automatic repetitive manufacturing of standardized and individual products, as well as the computer controlled integration of the manufacturing process with downstream or upstream processes, as well as customer/market demands.

The reviewed literature and current state of development shows that in construction industry, computer aided systems and tools have so far been mainly developed and deployed in the design, concept and engineering field. In construction, forms of integrated computer aided support, such as CIM, or more advanced forms, such as machine, system based industrialized customization, are not currently realizable due to the labor based and low-tech nature of the construction process itself, which necessitates a steady back and forth conversion from digital to analog and manual procedures. Due to the lack of “M” (Manufacturing/Machine Technology), “C” and “I” cannot unfold their potential. Furthermore, more and more complex products have developed on the basis of CAD (Computer Aided Design) and CAE (Computer Aided Engineering) planning tools, which have enhanced the complexity of the manually handled construction even more – which is in tune with the above stated concept of complementarities and co-adaptation.

Information can be seen as a common element of development, planning production and product. Based on the knowledge about a prospective customer, information is embedded in a product through design and production. Fujimoto, T., famous for his research on the TPS, even goes one step further and claims that consumers consume not goods or services but information: “...what he or she consumes is essentially a bundle of information delivered through the car rather than the car as physical entity” (**Fujimoto, 1999**).

Similarly, Piller describes production as a process whereby physical materials are transformed through machinery, organization and information into products (**Piller, 2006**). From this information point of view, it is necessary to see all steps of the value creation process as a set of complementary subsystems, which are jointly embedding information

and transforming physical materials through information in order to create value. Starting with CNC (Computer Numerical Control) and CAE, since the 1970s, computer aided systems and software tools in the manufacturing industry in general have allowed for new ways of efficiently handling of the flow and transformation of information in design, manufacturing and delivery operations (related to complex products). So far, “computer aided” systems and software tools have been developed and are continuously being refined to assist in every life-cycle phases and their related aspects (*Table 1-2*).

Table 1-2: “Computer aided” systems and software tools can assist in every life-cycle phase.

Product life cycle Phase	Computer aided systems and software tools
Design & Concept	CAD (Computer Aided Design)
	Rapid prototyping
	Computer aided demand forecasting
	Off- and on-line product configurators
	Software tools for collaborative design
Engineering	CAE (Computer Aided Engineering)
	FEA (Finite Element Analysis; analysis of functional aspects e.g. analysis of statistical aspects, heat transfer, motions, mechanics)
	Mass properties analysis
	ECA (Electronic Circuit Analysis, e.g. related to electronics products)
Manufacturing Preparation	DFMA Software (Design for Manufacturing and Assembly Software, e.g. analysis of module structure, cost, etc.)
	Software for analyzing tolerance, fit and interference of parts/modules components in the manufacturing process
	Software for simulation and optimization of manufacturing set-ups
Supply Chain Management	Computer aided MRP (Material Requirements Planning)
	Computer aided supply chain optimization
	Computer aided manufacturing resource planning
	ERP-systems (Enterprise Resource Planning)
	Computer aided manufacturing planning and control (in German: “Produktionsplanung und Steuerung”, PPS)

Manufacturing	CAM (Computer Aided Manufacturing, including CNC, robotic control, computer aided scheduling on shop floor level, automated generation of work instructions, etc.)
	Automated material handling (e.g. AGVs, cellular Logistics) and intelligent warehousing
	CAQ-Systems (Computer Aided Quality Systems)
	Machine and plant maintenance automation
Sales and Customer Relation	Sales-force automation
	Record of customer activity (interaction with company, preferences, habits, needs, etc.), recommendation engines (Google Amazon, etc.)
	Remote diagnostics
	CAFM (Computer Aided Facility Management)
	Computer aided maintenance scheduling
End of life	Modeling and simulation of disassembly operations
	Re-assembly simulation

Table 1-2 does not present all available tools, but gives a rough overview of the spectrum over which computers can assist in today's product generation process. A multitude of highly specific tools (industry specific, task specific, and product specific) exist and new tools are being continuously developed.

Today, besides the generation of highly specific tools within the fields categorized above, the integration of tools into interconnected tool systems that cover process chains spanning several fields categorized above (and thus life cycle phases) is the aim of CIM (see for example **Rehg & Kraebber, 2005**). From an historical/evolutionary point of view, the advance of computer technology has been allowed to shift from NC (Numerical Control) and DNC (Direct Numerical Control, e.g. simple punch card systems) of the activities, motions and speeds of machine systems (and means of production in general) to CNC (Computer-controlled Numerical Control, see for example **Kief & Roschiwal, 2011**). The integration of the computer with numerical control systems represented the introduction of a new control interface which allowed for simpler programming and re-programming, and thus for simplification of manufacturing operations and more flexibility (**Scheer, 1990**). From the 1980s onwards, a new highly interdisciplinary research and application field "CAD/CAM" was formed, which aimed at integrating computerized tools and systems from the planning and engineering filed with manufacturing and machine control systems (**Anderl & Castro, 1990**).

In the 1980s, attempts followed to automate the generation of parts lists and, bound to this, the scheduling of material flow and work instructions on shop floor level (e.g. Heim Automated Parts Pick-up System by Sekisui Heim). This development was followed by the deployment of so called ghost factories in Japan from 1985 onwards, in which 2 of 3 production phases were completely autonomous. In the Minokamo factory of the Yamazaki Corporation, and the Yamanashikomura factory of the Fanuc Corporation, all work tasks were done by robots and autonomous self-guided vehicles that commissioned flexible manufacturing centers (for further details, see **3.3.6**).

From the 1990s onwards, the “CAD/CAM” field evolved into CIM (see for example **Scheer, 1990; Klause, 1992**). The focus was now broader and the idea was that more and more fields and tools and also business economic issues (e.g. computer aided forecasting or demand planning) could be integrated by computerized systems to form continuous process and information chains. In the following decade, the idea of MC continued that idea by showing that even the customer (beginning and end point of any product generation) can become part of such process and information chains. With off- and on-line product configurators, for example, tools were developed which extend the idea of computer integration fully into the customer’s needs and activity field, allowing for more or less direct linking of the customer (and his activities and demands) to the manufacturing system. The concept of MC was advanced by researchers and companies alike (see **Piller, 2006**; see also **2.3**) and new ways for the computer based interaction of economic enterprises, manufacturing systems and customers were developed (see for example **Reichwald & Piller, 2009; Pine & Gilmore, 1999**). It was, on a greater economic level, complemented by the concept of the RTE (see also **2.3**).

In parallel, continuous advances in the automated transmission and processing of information (knowledge-based systems, artificial intelligence, see for example **Lämmel & Cleve, 2008**) were made, allowing for individual computer aided applications, as well as process chains to be made more and more autonomous. Recent approaches have been made, aiming at cognitive factories (**Zäh et al., 2009**) and the application of swarm robotics and cellular logistics in manufacturing (see for example Kiva System’s warehouse solutions or Dematic’s Multishuttle) in order to make autonomous manufacturing systems highly flexible. Besides the above given historical/evolutionary point of view, systems and tools can be considered from a macro/micro economic point of view. According to Scheer (**1990**), two major categories can be built, distinguishing between systems and tools related more to business operations (macroeconomic, e.g. computer aided demand planning) and those more related to technical aspects (micro economic, e.g. CAD, CNC, CAM, CAQ). Furthermore, according to Scheer (1990) it can be categorized into systems and tools supporting the planning phase and those supporting the realization phase. The table above (*Table 1-2*) – considering the more detailed life cycle phases and the addition of new phases - can be considered as an advance of this view. Similarly, CIM integrates macroeconomic systems, microeconomic systems of all life cycle phases. For successful integration knowledge from a variety of different backgrounds is necessary:

1. Designers and product engineers (in order to cover product related issues and changes)
2. Industrial engineers (having knowledge about manufacturing strategies, processes and machines)
3. Electrical engineers (information transmission and processing on hardware level)
4. Information and computer scientists (information transmission and processing on a software level)

In construction, computer aided systems and tools have been mainly developed and deployed in the design, concept and engineering fields (e.g. computer aided generation of geometries or functional distribution, computer aided optimization of cost, statistical systems, material properties, rapid prototyping, etc. – see for example **Hovestadt et al., 1989; Anderl & Castro, 1990; Hovestadt, 1994; Hovestadt & Hovestadt, 1998; Hovestadt 1998; Hemmerling & Tiggemann, 2010**). Additionally, during the last decade – according to interviews with members of board of directors of the International Association for Automation and Robotics in Construction (Interview with **Navon, 2010**) - papers handed in for the annual conference show that the research focus had shifted from “hard” machine technology (e.g. Automation and Robotics Applications, Robot Technology) to “soft” issues (automated data acquisition and monitoring, information and computational technology, management and social issues; see also **2.4**). Some rare research attempts have aimed at the simulation of construction processes (for example in some Japanese companies) or at the computer or RFID supported supply chain management, or construction management (see for example **Helmus et al., 2009; Caldas & O'Brien, 2009; Kazi, 2005**). A field of growing importance is also the computer aided management of the use phase (maintenance, repair, services) of buildings (also referred to as CAFM, see for example **May, 2006; Kazi, 2005; Wood, 2009**). Researchers are also working on the development of off-line and on-line product configurators (for example **Hvam et. al, 2008; Westerholm, 2009; Knight & Sass, 2010**). Furthermore, the field of Building Information Modeling (BIM, see for example **Eastman, 2008; Andersson et al., 2010**) is advancing fast and is developing methods and technologies for the processing and transfer of information between various steps, processes, tools and life-phases in construction.

However, all in all, it can be concluded that forms of integrated computer aided support such as CIM, or more advanced forms as MC and RTE, are currently not realizable in construction due to the labor based and low-tech nature of the construction process itself. The labor based construction process requires that digital information be converted into manually executed work procedures (and back; for example for on-site construction progress and quality control) and finally human activities that are not 100% predictable and controllable. The situation is worsened by the fact that the current conventional construction equipment represents, from the viewpoint of ICT, “dead” equipment that is purely human-mechanically controlled. Such equipment cannot be controlled in a CNC-like manner, nor can it be integrated in the sense of CIM (as has been deployed in the real world manufacturing industry for decades, as described above) with other upstream, parallel or downstream computer controlled or aided processes. Machine or manufacturing technology, especially on the construction site (where the majority of work activity and

assembly operations is conducted) represents the bottleneck for physically, informational and organizationally uninterrupted/continuous process chains that span the whole value chain (or the life-phase of the product) and would allow the linking of the customer (including his needs, activities and experiences) more or less directly to the executing manufacturing system.

1.5 State of the Art Machine Technology in Construction

Machine technology is one of three central means of production (material, machines, human labor, for a more detailed examination, see **2.1**). In industries which manufacture complex products (e.g. the automotive industry, aircraft industry, TBM based tunneling, shipbuilding industry, for an analysis of this topic, see **3.3**) and which have in the past made major improvements in efficiency and related costs for products, machine technology has become the preferred means of production and has evolved in tune with product structures, organization and information technology. In general, the manufacturing industry and in particular the implementation of scientific management and line-based manufacturing, developed further to automation technology and finally to robot technology based manufacturing, which can both be seen as advanced forms of machine technology (see also **2.4**). Automation and robot technology, along with modular approaches (from both machines and products), inbuilt flexibility, intelligence and new organizational forms (e.g. pulling production, variant production, MC) today enable more and more the individualization of products on the basis of highly industrialized manufacturing systems.

An underdevelopment or a complete lack of machine technology would not allow the efficient closing of the value chain loop in manufacturing. With rising complexity of products, inbuilt function technologies and materials, the use of machine technology and its precision is a must. Additionally, unlike human labor, machine performance is much more calculable in terms of time, precision, quality and cost. Furthermore, whereas the human being and systems involving human beings are subject to natural physical and cognitive limitations, machine technology is basically unlimited in performance and incremental or disruptive performance increases. According to Scandinavian researchers (see **Ahman, 2010; Lindl & Song, 2010**), in a labor based construction, through the optimization of organization and management, a maximum increase in productivity (i.e. work productivity, time, etc.) of 30% (at best!) might be possible. The manufacturing industry has already proved that machine technology allows for significant increases in certain types of productivity (see **3.3**) which can then be a driver of the financing elements for innovations related to the product itself (presented in more detail in **7.2.1**).

The reviewed literature and state of the art development in construction technology show that when considering the aircraft or shipbuilding industries as mechanized industries that are on the transition to automation, the building construction industry in general can be considered as never having reached the level of mechanization-adequate machine technology on the construction site – the final “assembly line” in construction. It can be shown that (except for the approaches developed in Japan from the 1980s on) the construction industry has been time and locally restricted (e.g. Sommerfeld’s *Bauhelling* in Germany in the 1920s, or mechanization attempts in USSR’s construction industry in the 1960s/1970s) in the attempts to develop a mechanized level. Approaches to automated or robotic construction have not overcome the research or prototype level and even the use of networked and GPS guided “conventional” construction machines (which is, for example, already a reality in precision farming in the USA, see **3.3.6**) is in construction still a

farfetched vision. Thus, the integration of construction equipment with advanced organizational concepts (JIT, JIS, pulling production, digital construction site, and integrated real-time quality control) and forms of CIM are also not efficiently realizable.

The focus in this work is on on-site building construction processes which can be considered as an assembly or final (fixed site) assembly process (for a breakdown of manufacturing types, see **2.3**), where the majority of parts and components are put together. Although more and more components can be produced off-site (see **3.1**) in conventional construction (housing, offices, high-rise buildings, public buildings, etc.) the majority of work is done on-site and labor based. Even in major prefabrication industries (see **3.2**) only a tiny fraction of companies manage to move up to 80% of the work to off-site factory or factory-like environments. The remaining 20% of work is conventionally done on-site, and is labor based, and at the end accounts for most of the time necessary to deliver the building.

Conventional building construction machines (see for example **Chors 1995; Kunkel, 2009; Schach et al., 2011; Hellstern, 2011; Chors, 2012; Browning, 2012**) are, in the majority, multipurpose machines that are from an informational point of view “dead” equipment (no GPS, no communication with other equipment, manual input of operation information by workers, no servomotors with encoders, no sensor systems, etc.) which do not even fulfill the criteria of mechanized manufacturing (such as within the aircraft industry as shown in **3.3**) and is a long way from being intelligent, automatic or robotic. Complex special purpose machines that are to some extent mechanized, intelligent and integrating multiple functions in a production line like manner as in use in open cast mining (see for example **Chors & Oberdrevermann, 2004**) are usually not used in building construction. *Table 1-3* briefly depicts the development of on-site building construction machines. The table shows that from a historical/development point of view, on-site building construction machines have never reached the level of computer controlled, automatic or robotic equipment. A combination of multiple functions in one complex machine that combines processes to form a chain (as, for example, in farming and open cast mining; see *Figure 1-2*) has not taken place in building construction. Interesting approaches from the 1960s and 1970s, such as overhead conveyor excavators (e.g. Komatsu D 50-6, Homag K 90) that tried at least to improve the movement of soil from an excavator to the carrying loader were later abandoned (**Chors 1995**).

All in all, complexity of current on-site building construction machines can be considered as low, both concerning its technological advancement as well as concerning the functional integration into connected process chains. *Figure 1-3* shows that the relation of machines to humans on the construction site has so far been even worse than a 1:1 ratio (one operator to one machine) and for example the positioning operations conducted by tower cranes or mobile cranes often involve a group of workers to conduct the positioning operation. The tendency towards small scale equipment (mini diggers mini excavators), the lacking functional integration, the 1:1 (or worse) operator – machine ratio along with the above described lack of computerization or communication ability, limits the capability generating a PME as in other industries, (see **2.3** and **3.3**) to a very basic level.

Table 1-3: Historical view: Development of conventional and frequently used building construction on-site equipment.

Time Period	General Direction of Development
e.g. Egypt, construction of pyramids	Masses of humans + simple tools
Before Middle Ages	Humans + mechanical equipment powered by animals
From Middle Ages onwards	Humans + mechanical equipment powered by wind/water
From 1800 onwards	Humans + mechanical equipment powered by steam engine (first rail-guided, later “free”)
From 1900 onwards	Humans + equipment powered by electrical motors and diesel motors
From 1930s onwards	Humans + equipment powered by electrical motors and diesel motors, equipped with pneumatic tires and chains
From 1950s onwards	Humans + small scale equipment (e.g. mini excavators, mini caterpillars) – hydraulic technology
From 1980s onwards	Humans + large scale and high payload (hydraulic) equipment (e.g. rear dump trucks, hydraulic excavators)



Figure 1-2: Functional view: a combination of multiple functions in one complex machine that combines processes to a chain (as e.g. in farming and open cast mining) has not taken place yet in on-site building construction. The picture shows a machine integrating multiple functions in open-cast mining.



Figure 1-3: Conventional construction in practice: Supervision of unit installation process by four workers (3 operational floors, 1 ground floor) and one tower/mobile crane operator. The installation of the unit took 25 minutes. Cadolto construction site, Augsburg, Picture: Linner

Table 1-3 shows that building construction equipment is not yet (as with the general manufacturing industry from the 1960s onwards) computer controllable and reprogrammable. Furthermore, instead of integration of processes and an adjustment of products (such as lightweight technology), as can be seen in other manufacturing fields such as the automotive industry, the increase of force and payload has been in the focus of machine development in the building construction industry since the 1980s. Neither approaches for either integration of processes by construction equipment or the development of more complex computer controlled equipment have been attempted.

The above described conventional building construction equipment is controlled (at best) in a 1:1 manner and the possibility of supervisory control of advanced machine systems that exists today (for a more detailed analysis of the potential of supervisory control, see **2.4** and in particular **6.2.6**) is not even considered. Even worse is the situation with smaller machines and tools used on the construction site (e.g. wheel-barrows, shovels, standard Hilti-equipment). This equipment is low-tech and not embedded in best practice work procedures, which have become the standard in manufacturing since Taylor's time-and-motion studies. Compared to Dell-like high-tech workbenches, where workers assemble highly complex and customized computers (see also **2.3**) the low-tech nature of on-site building construction becomes even more obvious. Although this is hard to prove, one gets the impression that the situation on construction sites, especially in central Europe, in terms of organization, work conditions, reputation, quality assurance, salary, productivity) could be considered to be worse than the situation in the continuously in our media criticized Chinese factories that produce our electronics, textiles and appliances.

The current standard in conventional construction machine technology as outlined above is embarrassing considering the fact that the roots of modern machine technology (and thus also the computer technology, automation technology and robot technology) lie in the architectural and geometry based sciences (Da Vinci, Brunelleschi, Ghiberti, Willis), providing the basis for the continuous evolution and finally digitalization of machine kinematics and machine systems. An exception to this phenomenon can be observed only in the field of road, bridge and dam construction, as well as in tunneling where linear and less complex products allow the rather easily setting up of SEs, JIT JIS and finally automated systems on the construction site (see therefore as an example a detailed analysis of the linear, on-site and machine based TBM tunneling process in **3.3.1**).

Below, the roots of modern machine technology (which is today deployed in almost all industries except the construction industry) will be briefly depicted. Then, some rare approaches and prototypes for machine-centered and systemized ONM will be reviewed and analyzed. It will be seen that approaches to on-site machine centered and factory-like manufacturing – except for the approaches discussed later on, and developed in the main part of this thesis - have not advanced beyond the prototype phase or small scale application. Levels of advanced mechanization, as in the shipbuilding industry, aircraft industry and the TBM – tunneling industry (which also manufacture on-site/fixed-site-like), or even stages of automated or robotic on-site production or assembly, have not yet been achieved.

1.5.1 The Roots of Component Manipulation in the Middle Ages

The evolution from simple machines to advanced computer controlled robotic manipulators is also the story of the evolution of a methodology of kinematic synthesis. Kinematic synthesis (**Ferguson, 1962**) refers to the geometrically organized combination of machine elements in forming an intended motion for a particular work activity. With the evolution of machine systems, one can further see the separation of the geometric (kinematic) view from a forces related view (dynamics). With the rise of potentially unlimited and consistent power sources on basis of the steam engine, the focus shifted towards research in kinematic synthesis as a force to power a mechanism was from then on broadly available. Force transmission, therefore, although not completely inseparable from kinematics, was not in the main focus of interest any more. The evolution from machine elements to complex kinematic structures, and finally to systemic mathematic analysis and synthesis methods, directly leading to modern robot control can be subdivided into phases as outlined in *Table 1-4*.

Table 1-4: Evolution from machine elements to complex kinematic structures and finally to systemic mathematic analysis and synthesis methods, leading to modern robot control (fusion of information obtained from **Ferguson, 1962; Laurenza et al., 2005; Moon, 2007; Galluzzi, 1996**)

Time Period	Achievement	Description of Achievement	Key Person(s)
1500s	Description and classification of machines	Da Vinci started to scientifically describe and analyze existing mechanisms and made initial attempts to classify machines. On the basis of his work he invented, developed and envisioned machines for a multitude of fields ranging from construction to military.	Da Vinci
1600s	First phase of machine synthesis by problem analysis	Introduction of principles of mechanical engineering. Development of machines according to systemic abstractions of the problem, task or process and its transformation into machine systems.	Brunelleschi; Ghiberti
1800s	Tables for kinematic pairs	Classification of mechanisms according to the type of conversion from one type of motion into another type of motion (e.g. rotary into linear motion). Tables as provided by Monge and Hachette were popular among practical machine builders	Monge; Hachette
1820s	Definition of machine elements and rules for application in element chains	Introduction of six orders of machine subdivided into classes and species <ol style="list-style-type: none"> 1. Recepteurs (receivers of motion from prime mover) 2. Communicateurs (transmitting elements/links) 3. Modificateurs (modifiers of velocity) 4. Supports 5. Regulateurs (governors) 6. Operateurs (tool at the end) 	Borgnis
1841	Start of mathematical kinematic analysis and description	Willis, R. can be seen as the father of theoretic kinematics and laid down his principles in the book <i>Principles of Mechanisms</i> Focus on “pure mechanism” and development of concept of relative displacements of machine elements.	Willis

		Every machine can be broken down into interconnected machine elements.	
1880s	Use of mathematical models for kinematic synthesis	Reuleaux advanced mathematical models for kinematic analysis on the basis of the work of Willis Reuleaux introduced the concept of inversion as a mathematical model for kinematic synthesis	Reuleaux
1965	Homogenous transformations and rotation matrix applied to robot kinematics	Allows coordinate values of each part of robot to be described according to a common reference frame. Creates the basis for the control of the actuators by microprocessors, computers etc.	

Interesting to note is that a clear separation of the construction and architecture fields from the field that was concerned with machine technology and machine synthesis as we know it today took place after Reuleaux. Leonardo Da Vinci was active in nearly all fields of invention and some of his inventions for the military (e.g. the Wall Defense System presented in Codex Atlanticus, **Laurenza et al., 2005**) are architectural constructs with in-built machine elements. Brunelleschi conceived the architect as a “dictator” who has to plan or control the design as well as the machine systems that build the design. Monge at the Ecole Polytechnique was concerned with the application of geometrical descriptions in a multitude of fields. Willis at Cambridge University, Professor of Natural Philosophy, and famous for his achievements in the mechanical engineering field (see for example **Willis, 1841**), wrote several architecture related books and was finally asked to form a civil-engineering faculty at Cambridge. Reuleaux was also a man with broad interests and was a supervisor of generalists such as Karl Benz and Hugo Junkers (**Moon, 2007**). The analysis (*Table 1-4*) shows also, that the roots of the science of kinematics and thus the development of machine technology, as well as automation and robot technology (which can be seen as advanced machine technologies, for further explanation, see **2.4**), were clearly related to developers that had a strong foothold in construction industry, such as Da Vinci, Brunelleschi and Ghiberti, and later also Willis and Reuleaux.

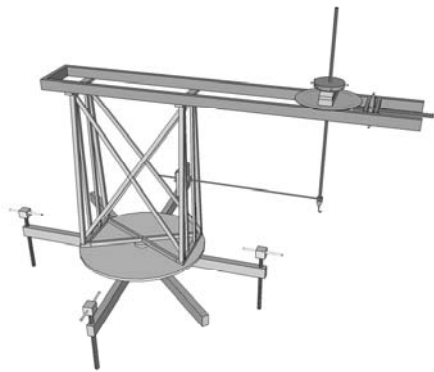

Da Vinci's mobile manipulator for positioning and orientation of building blocks in a three-dimensional working space (according to **Galluzzi, 1996**).

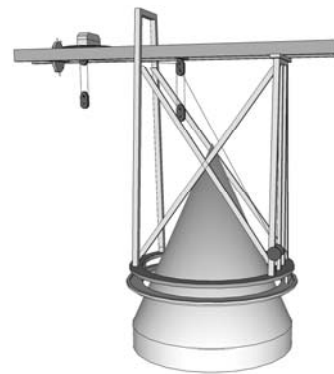

Ghiberti's fixed type OM for positioning and orientation in cupola roof construction (according to **Galluzzi, 1996**).

Figure 1-4: Examples for use of manipulator technology in the Middle Ages.

However, its potential for construction, especially in later phases, was not utilized further. Da Vinci, Brunelleschi and Ghiberti planned and realized machines for construction which could be seen as early types of manipulators. As stated in **2.4**, manipulators allow for a combination of more or less complex positioning and orientation operations (kinematic body positioning and orientation). The complexity and sophistication of those construction type machines at that time can be considered to be on a similar level as machine technology developed for other industrial fields (e.g. the military, **Laurenza et al., 2005**). Just as robot technology in the 1980s was considered in Japan to be a new type of machine technology that held the potential to be utilized in the construction industry (see also **2.4**), machine technology at the time of Da Vinci, Brunelleschi and Ghiberti was also considered to be a core technology that could be introduced in any industrial field and made "ubiquitous". In that context Da Vinci's mobile manipulator for positioning and orientation of building blocks in a three-dimensional working space and Ghiberti's fixed type OM for positioning and orientation in cupola roof construction can be mentioned as an example of the use of object manipulation technology from 1600 onwards (*Figure 1-4*).

1.5.2 *Bauschiffe* (from 1910 onwards)

During the 1920s, architects and contractors were fascinated by the idea of Taylorism and industrialization. This was prompted by a housing shortage after the First World War. The aim was also to rationalize handcraft, architecture and industry, as well as to provide an interdisciplinary link between them. At this time, well-known architects like Walter Gropius also dealt with this idea. More interesting are those who put their ideas into practice. From

the 1920s onwards, a few architects and constructors transferred the idea of the *Bauschiff* to construction. A *Bauschiff* is a frame construction that spans the site where large ships are built and thus establishes a kind of factory environment that provides overhead cranes working platforms and logistics systems. The first highly advanced *Bauschiff* that provided the possibility of operating multiple cranes in parallel was Harland & Wolff's shipbuilding yard, which constructed the Titanic and its two sister ships, and introduced the idea of scientific management to fixed-site ship manufacturing (for a detailed analysis of Harland & Wolff's shipbuilding yard, see 3.3). It can be assumed that the *Bauschiff* concept adopted by construction was inspired by Harland & Wolff's approach, in particular.

1. **Adolf Sommerfeld's Bauhelling** (from 1920 onwards): The building contractor Adolf Sommerfeld was born in 1886 in Colmar and completed an apprenticeship as a carpenter. After that, different jobs followed and he established a construction company in 1910. Sommerfeld was not only a contemporary of Gropius but also a good acquaintance of him. Both were interested in the optimization of organization and logistics of production processes in the building industry (Kress, 2008). This included also the standardization of components and the development of industrial assembly methods with a focus on an inexpensive and fast production (Kress, 2008). He was also specialized in suburban development areas and concentrated also on serial single-family houses. In 1928, for example, he commissioned Gropius for the project to plan a "house factory". Also, the development department of Sommerfeld's construction company looked into developing a system for serial houses. They thought that rational planning and corporate organization as well as an increasing degree of mechanization would lead to rising flat production figures and a reduction in construction costs by fewer workers (Krass, 2011). One idea was the *Bauschiff* (Schlee & Michels, 1929) which literally means "building ship" in English. This system was realized in the building up of the settlement in Merseburg. The *Bauschiff* is a construction system with gantry cranes on tracks. Parallel to the tracks for the gantry cranes, a second track system, which is connected to the train station was constructed to optimize the delivery process. With these tracks it was possible to transport the building materials directly to each site. The special construction technique influenced also the urban design. The unusual construction method limited the design flexibility. The challenge for the architects was to combine the requirements of the user with the possibilities of realization. The settlement in Merseburg comprises 750 flats over 90,000m² and was constructed in eleven months. At the time, the *Bauschiff* was a major step forward. Also, the policy at that time was interested in evaluating such techniques in the building industry and propagating those ideas (Junghanns, 1994). They established a specialized association, with well-known people from the time, like Walter Gropius, Ernst May and Adolf Sommerfeld himself. Although these *Bauschiffe* were successful in Merseburg, this idea was not further developed; only the architect Ernst Neufert tried to optimize this system and published the whole procedure in his book '*Bauordnungslehre*'.

2. **Neufert – *Bauschiff/Hausbaumaschine* (1943):** In 1943 Neufert published the book '*Bauordnungslehre*' and summarized in it collected data about units of measurement, and tried to systematize measures in architecture of different cultures. In 1943, this book seems to have been at least equally successful as the book '*Architects' Data*'. As late as 1960 Gotthelf's expectation was still that '*Bauordnungslehre*' would be the main work of the author (**Gotthelf, 1960**), but in 1965 the third and final edition was published. When comparing construction techniques, the practical sections with the accompanying examples in the first edition are very interesting. Neufert explained in his examples how to optimize the constructing process of a building. He was thereby probably inspired by Walter Gropius and Adolf Sommerfeld and designed a *Hausbaumaschine*, which literally means a "house constructing machine" in English. This idea has many parallels to Sommerfeld's *Bauschiff*. Both have the idea of installing the factory directly on the building site and of using tracks and something similar to gantry cranes to span the object being built on it. The main difference is that Neufert optimized and rationalized the whole construction process. Every step was given in detail, with the exact time needed. The main part was a steel construction holding the formwork for *in situ* concrete and could be compared to Sommerfeld's gantry cranes. With a special slide mechanism, this steel construction could also slide on tracks (**Neufert, 1943**). Each worker was to be specialized in his working step in order to save time. First, the foundation was to be built and then workers were to install the steel construction on rails. After that, floors were to be successively constructed in parallel processes. A defined production schedule would ensure an optimal completion date. The construction would run day and night, 24 hours a day, seven days a week. Although Neufert planned the whole process in detail, the project has never been realized.

1.5.3 Mechanized On-site Construction in Russia (since the 1940s)

In the former USSR, and especially in Russia itself, from the 1940s onwards prefabricated and especially precast concrete element technique and systems were used in combination with a systemized/preplanned organization of the on-site workplace and innovative on-site machine settings. OFM techniques were developed (precast concrete element technique and systems for individual buildings and for mass housing) as well as complementary fast-joining mechanisms. The upgrade in off-site technology was accompanied by an upgrade of on-site methods. On-site specialized crane end-effectors for the positioning of precast and prefabricated elements, portal cranes, tower cranes positioned on rails, pull up and covered workspaces (for winter construction) were deployed. Those methods were used frequently for the construction of functional buildings (industry buildings, offices) and for condominiums and mass housing. Furthermore, they were accompanied by systemic research and science concerning the improvement of off and on-site construction methods. The development in Russia at that time thus showed the use of prefabrication on a large scale and thus a tendency towards the (complementary) mechanization of on-site construction processes. However, with the decline of Russian political influence, and the

split up of the USSR most efforts were abandoned and the desired level of automation in on-site construction was not achieved.

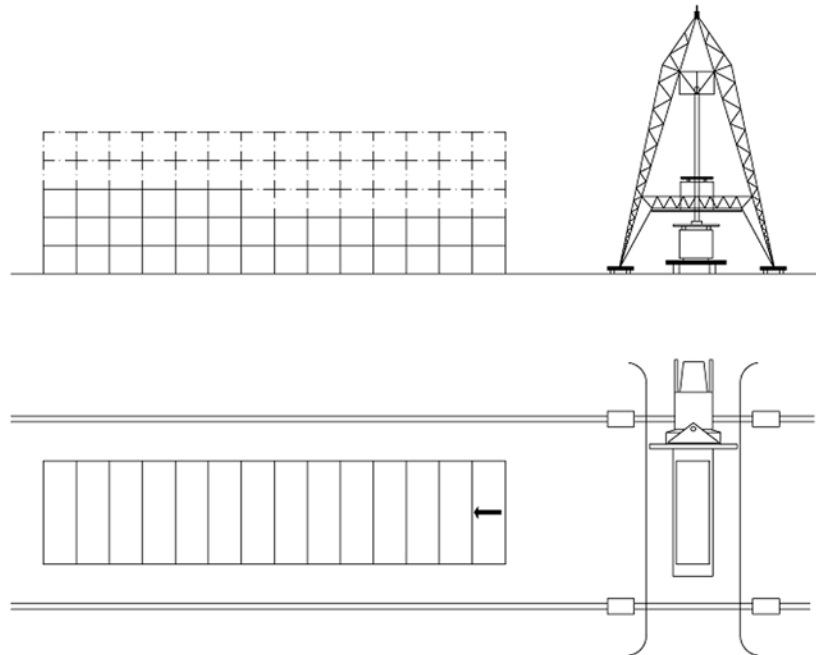

Figure 1-5: use of gantry cranes to position prefabricated three-dimensional space frame units (according to **Ledderboge, 1962**) for the fast on-site completion of condominiums.

The following machine-supported methods for on-site construction were used by the Russians to complement prefabrication:

1. Use of rail-guided gantry crane systems for element positioning
2. Positioning of tower cranes on rails in connection with completely preplanned and systemized on-site process
3. Use of gantry cranes to position prefabricated three-dimensional space frame units (see also *Figure 1-5*)
4. Lifting up of roofs manufactured on ground along columns
5. Lifting up (from roof along columns) of floors manufactured on ground
6. Winter construction projects and covered/closed worksites

An interesting method with high relevance to the topic of this thesis was the use of gantry cranes to position prefabricated three-dimensional space frame units. The space frames (steel or concrete) were completely prefabricated in the factory and delivered by trucks to the site. Trucks were able to position themselves under the gantry crane. The gantry crane would then pick up the unit and positioned it following a predefined sequence. Site of the building, size of transportable elements and size and design of the gantry crane were fully

synchronized. A detailed analysis of the mentioned construction techniques in Russia was conducted by Ledderboge (1962).

1.5.4 7-Degrees of Freedom Manipulator Kinematics for Construction Purposes: Location Orientation Manipulator (1969)

In 1969, one of the first 7-DOF manipulator kinematics for construction purposes was designed by Wachsmann and his students Bollinger and Mendoza. Except for some exhibitions in the seventies, in which this project was briefly described, the Motion Machine or Location Orientation Manipulator (LOM) remained largely unknown. The LOM and its kinematic structure were fully modularized, so that it has the potential to be adjusted to various requirements (see also *Figure 1-6*). A combination of several LOMs can form a group of cooperating assembly machines (Bock et al., 2010). It is highly likely that the LOM was developed by Wachsmann as a system that would be able to position and align elements of his factory-produced and prefabricated systems (e.g. the Mobilar Structure). The realization of 7 degrees indicates that complex assembly operations were intended.

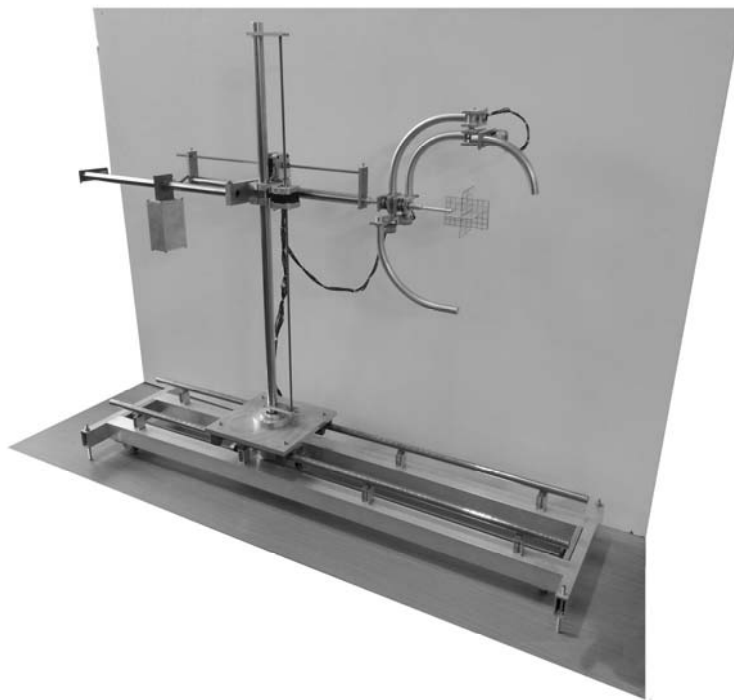

Figure 1-6: First 7-DOF manipulator kinematics for construction purposes by Wachsmann. Scale model built by the Chair for Building Realization and Robotics.

1.5.5 Fusion of Prefabrication and Lifting Technology: BMW-Tower (1972)

The BMW-Tower, headquarters of BMW in Munich, was erected by a highly innovative construction method which synchronized the construction technique and the (structural) design of the building. The individual office floors were suspended by massive steel cables from a central function and supply core (see also *Figure 1-7*). In contrast to other approaches from that time (and later) in high-rise construction, the structural design was also used as basis for the construction technique:

1. First the massive concrete core was built by vertical slip forming technology
2. An on-site GF (fixed site type) was installed
3. Within the GF, the individual floors were assembled (ground level) and finished (including the installation of fully prefabricated the 6th – 7th floor facade elements within the GF)
4. The suspending system was used to push up the constructed floors; the installation and de-installation of a push-up mechanism, as used by Kajima and Skanska for example (see 5.2.4 and 5.2.5), was not necessary.

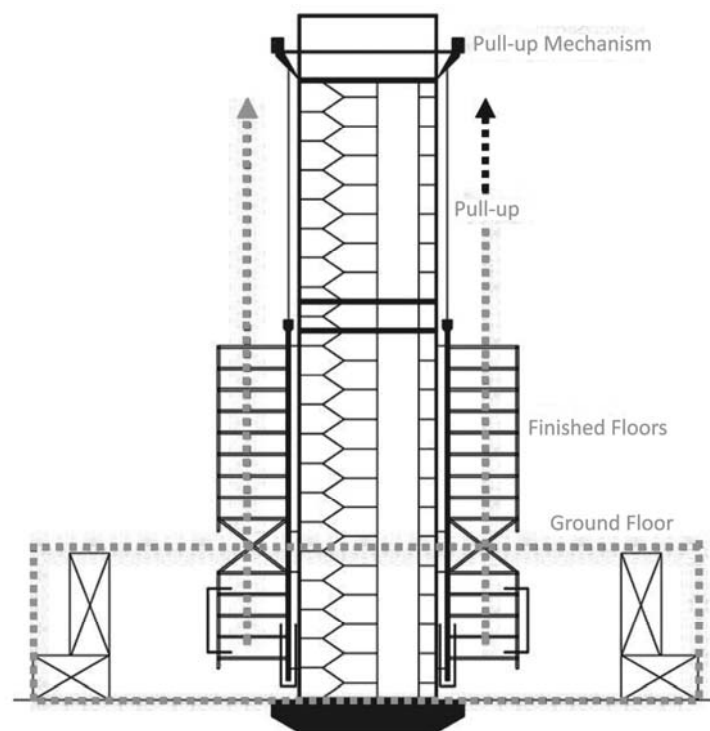

Figure 1-7: Schematic representation of the on-site fixed type manufacturing process used to construct the BMW-Tower in Munich (according to **Weller, 1986**).

1.5.6 Zuse's Extendable/Retractable Helix Tower (1985-1995)

Apart from achievements in the field of computer technology, Zuse, through his background in civil engineering, was interested in developing methods for automated construction. From 1985 onwards he made his ideas more concrete and started to work on the construction of high buildings that could be retracted or varied in height (*Figure 1-8*), to enable them to withstand strong storms, for example. Subsequently, Zuse developed fully functioning prototypes (Helix Tower 1 and Helix Tower 2, scale 1:30), of towers that could be extended and retracted automatically. The core element of the system was a magazine at the bottom of the tower that accomplished the positioning of metal segments and the lifting up of the structure. The design and the modularity of the individual segments were fully integrated with the positioning and lifting mechanism. Conceptually the magazine represents a fixed type of on-site factory, and seen from the location of the site factory and perspective of the general work flow therefore equals Kajima's and Skanska's automated construction approaches (for a more detailed examination of this two approaches, see **5.2.4** and **5.2.5**). A detailed analysis of the positioning and lift-up mechanism, magazine system and the design of the segments of the Helix Tower was done by Eibisch (**Eibisch, 2010**) as part of a restoration and rebuild project of the Helix Tower prototypes.

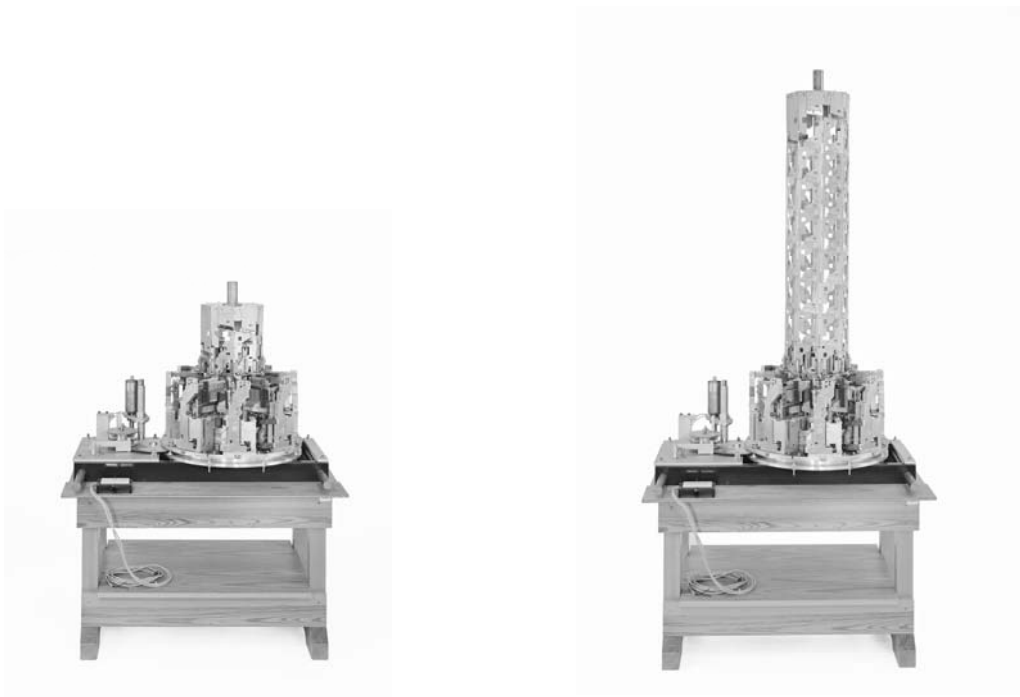

Figure 1-8: HT1 scale model, retracted (left) and extended (right). Zuse's first approach concerning the design of an auto-extendable and retractable tower construction (photo courtesy of **Deutsches Museum München**; Picture Numbers: BN_60761, BN_60762)

1.6 Research Question and Hypotheses: Focus on Machine Technology

On the basis of the current state of technology in the construction industry it was shown previously in this chapter that the critical parameter or chokepoint for the realization of advanced and continuously evolving product structures, organizational forms and informational aspects in the construction industry is the underdeveloped and largely absent machine technology, which would permit the integration of efficient product modularity and efficient organizational structures with efficient digital and automatic manufacturing. Current conventional construction machines are mainly multipurpose machines that are “dead” from an informational point of view (no GPS, no communication with other equipment, manual input of operation information by workers, no servomotors with encoders, and no sensor systems, etc.). In terms of achievement, as shown in **2.1** and also in **3.3.6**, labor based work activities are at certain levels of efficiency, productivity, quality and overall performance (including the ability to mass-customize) subject to natural limitations.

That the use of machine technology and the production of individualized and complex products do not exclude each other can be shown by the development in the machine tool field. Up to the 1960s, machine tools (e.g. for boring or milling) were mainly mechanical equipment with no more than four DOFs. From the 1960s onwards, computerized control was introduced, allowing those machines to not only be operated fully automatically, but also to be reprogrammable – laying the foundation for the combination of automation and flexibility (for example **Allwang, 2002**). With the advance of computer technology, the program and re-programmability was continuously improved. This development culminated in the generation of fully computerized machining centers with more than four DOFs and exchangeable tool heads (see also *Figure 1-9*).

Japanese ghost factories in the 1980s showed that multiple machining centers can be connected to fully automatic factories (for more details on ghost factories, see **3.3.6**). Robot technology today adds further flexibility to automatic machine centers through inbuilt flexibility, and through the shift to modularity and the fast and simple plug and play connections of individual robot segments (for further explanation, see **2.4**). Robotic logistics systems (e.g. cellular logistics; see also **2.4**) replace the rigid chain-like organization and the production line. Today they can connect multiple machining centers and automate the individual armament of those with material and specialized machine tools. Robotic machine centers, through integration with the above described developments particularly in the information management field (informational aspects, e.g. CIM, CAQM), enhance not only the flexibility, but also the quality and the speed with which products can be made.



Typical mechanical and non-computer machine tool with less than four DOFs and limited flexibility (1960s).



Advanced computer controlled reprogrammable machining center with more than 4 DOFs

Figure 1-9: Gain in flexibility through integration of machine tools with electronics and computer technology (photo courtesy of **Deutsches Museum München**; Raboma Machine Tool, Picture Number: R2121-10; Machining Center Hermle UWF 902 H, Picture Number: CD63624)

The central research question which arises, given the above discussed developments in general manufacturing industry and construction industry, concerns what advanced machine technology that integrates aspects of automation with the need for flexibility, quality and cost effectiveness could look like. As buildings are products that are always finalized on-site, and whose parts or components can only be prefabricated to a certain extent, machine technology for the construction site shall be a further focus of this thesis.

As shown above, machine technology for the construction site capable of integrating and processing the incoming parts and components is underdeveloped. It was shown that compared to the other three analyzed fields (product structuring; organization and management; and information management), manufacturing technology for on-site final assembly is not only underdeveloped, but that the lack of “M” (manufacturing technology) on-site prevents the possibility of integration and thus efficiency in or by concepts and technologies from the other three fields. Machine or manufacturing technology, on the construction site in particular (where the majority of work activity and assembly operations is conducted), represents the bottleneck for physically, informationally and organizationally uninterrupted/continuous process chains. These span the whole value chain (or the life-phase of the product) and would allow the linking of the customer (including his needs, activities and experiences) more or less directly to the executing manufacturing system.



Computer controlled machining and assembly center sitting on top of the building and rising with it (on-site SF), Shimizu Corporation, Japan

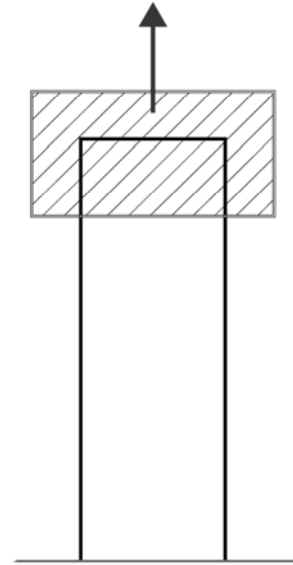

Schematic representation of the concept of on-site factories. On-site factories can have different locations and working directions and thus be used to manufacture all types of buildings.

Figure 1-10: Use of flexible and reprogrammable machining and assembly centers to construct buildings on the construction site

In this work, the possibility of installing automatic and/or robotic machining or assembly centers (later called on-site factories) on the construction site, and turning the construction site into a factory like manufacturing environment, is discussed. An example of the implementation of an automatic and robotic machining and assembly center to construct a high-rise building is shown in *Figure 1-10*. Such manufacturing environments integrate aspects of OFM with on-site assembly of parts and components in highly structured on-site environments. This is achieved predominately by, or with the support of, machine technology and machine systems on the construction site.

The hypotheses of this thesis therefore are as follows:

1. **Systems outperform stand-alone technological solutions:** The integration of STCRs to whole systems in on-site factories is the basis for on-site structured and factory-like work environments that reduce the use of the “risk factor” of human labor considerably. The means of production of human labor negatively impacts on the fast, cost efficient and high quality manufacturing of a complex product such as a building.

2. **Automated/Robotic On-site Factories can be developed for manufacturing any building typology:** Automated/Robotic On-site Factories can be installed at various locations on the construction site (on the ground, on top of buildings) and can progress in various directions (i.e. vertically upwards or horizontally) thus allowing solutions for almost any building typology.
3. **Automated/Robotic On-site Factories can mass customize buildings:** On-site factories can be used to automate the construction of individual and/or mass-customized buildings. Like any manufacturing environment, in the general manufacturing industry they can be developed as modular kits consisting of subsystems with in-built (robotic) flexibility or with modular flexibility (e.g. end-effector change) that can be fully synchronized with the buildings modular structure.
4. **Large-scale deployment requires the radical and co-adapted change of manufacturing, technology, organization, product and associated business models.** In order to be developed and deployed on a large scale, automated on site-factories need to be able to not only improve or double productivity, but to multiply performance (e.g. reduction of construction time to 1/10th compared to conventional construction, zero-waste, defect free product). This can be achieved by on-site factories which allow for continuous, JIT JIS material flow on-site on a 24/7 basis, reducing any idle or downtime in the site factory.
5. **Automated/Robotic On-site Factories can be the basis for RTE in construction:** Automated/Robotic On-site Factories can lay the basis for a construction industry which is able to produce or change buildings according to customer demands with minimal delay in a near real time manner. Subsystems of the on-site factory can be integrated as building technology into the building and reactivated for change, re-customization and deconstruction.
6. **Switch to an OEM-like industry structure:** In current construction practice, neither real modularity nor applications of connectors that allow for simplified and fast connection are common practice. In order to structure the on-site environment and reduce complexity on-site (e.g. through the number of assembly operations, or kinematic complexity) an OEM-like industry structure, shifting the creation of components, modules and units to internal and external company suppliers and integrating the principles of ROD has to accompany the introduction of Automated/Robotic On-site Factories.
7. **Instant realization of Automated/Robotic On-site Factories through coordinated R&D and technology transfer possible:** The economic feasibility of automated on-site construction has so far not been the focus of R&D activity in the field. A combination of short-term funding, long-term funding of industry consortia representing the whole value chain, in combination with innovation and technology transfer strategies, can create economically feasible approaches for automated/robotic on-site construction.

- 8. Reverse innovation:** A manufacturing technology that is able to mass-customize highly complex products such as buildings in a near real-time manner can be used for the individual, automatic and OPF, as is the case with the manufacturing of other complex products such as cars or aircrafts. The overcoming of the challenge to automatically manufacture buildings could not only necessitate the transfer of the technology to the currently underdeveloped industry, but also lead to concepts and technologies which are of high interest for the manufacturing industry as a whole.

Automated/Robotic On-site Factories represent computer controllable and flexible manufacturing technology that erases the necessity for forth and back conversion from digital into analog information on-site and is able to integrate and unfold the potential of advancing product structures, organization and informational aspects. In construction, forms of integrated computer aided support, such as CIM, or more advanced forms such as machine system based industrialized customization, are currently not realizable due to the labor based and low-tech nature of the construction process. The approach presented and discussed in this thesis intends to build a scientific basis for the development of on-site factories that would represent an adequate solution for introducing the missing “M” (Manufacturing Technology) on construction sites.

The approach presented in this thesis does not contradict recent developments in the fields of product structuring in construction (building with prefabricated parts and components), organization in construction (construction management techniques, lean construction, systemized controlling techniques, etc.) and informational management in construction (computer aided planning and cost optimization tools, building information management, digital construction site, etc.) but provides an approach for the construction site which would allow the integration of those approaches and allow for the increasing of their possibilities. Furthermore, the approach presented is fully compatible with approaches from the rapid manufacturing field that allows individualized, personalized parts and components to be produced off-site and integrated over structured modularity (chassis and infill approaches, platform approaches) into the building. However, this approach stresses that buildings are highly complex products that consist of a multitude of parts and components that are assembled on the construction site and which thus limit the possibility of rapid manufacturing technology or prefabrication approaches of being able to fully “produce” the building.

1.7 Research Method and Structure of this Thesis

In order to find answers to the search for a novel ONM technology introduced above, and in order to be able to discuss the stated hypotheses, existing approaches to STCRs and automated/robotic on-site factories have been systematically mapped, and analyzed qualitatively and quantitatively. Systemic analysis frameworks both for technical analysis and for analysis of productivity and efficiency related aspects were set up after the research in automated on-site factories was concreted about four years ago and had been continuously refined. Based on the analysis, a categorization framework was developed which considers the building typology, the location of the on-site factory and its general working direction. The categorization framework not only classifies the analyzed approaches but also gives an orientation framework for future developments by showing which types of approaches are feasible for constructing a certain type of building.

Furthermore, based on the identification of strengths and weaknesses of the analyzed approaches in an exploratory study, novel possibilities for the deployment of on-site factory environments have been tested. A reference for the explanatory study was the plan of a major Korean company (with which the research institute of the author is in contact) to construct its company headquarter with more than 100 floors in Seoul by automated on-site technology and by a performance of more than one floor per day. This approach shall later be used all over Korea (which has a huge demand for high-rise buildings) as well as in Japan where, as a result of the Tohoku earthquake, all major high-rise buildings will have to be deconstructed and re-constructed over the next decade under the premise of minimizing downtime. Similarly, the approach can be utilized in metropolitan regions (e.g. in China) where skyrocketing housing demand and building cost require novel solutions. In China, currently a major real estate developer (China Vanke Co., Ltd) and a major building technology manufacturer (Broad Group) have cooperated and demonstrated by a 30 floors high prototype building they constructed on the basis of high-level prefabricated components that they will soon be able to construct extremely large high-rise buildings (a 220-storey high-rise building is planned to host 30,000 people and another 636 floors high mega structure; for more details, see **Sheldon, 2012**) on the basis of their methods. The project is supported by the Chinese Ministry of Construction (Council of Human Settlement) in order to counterbalance the impact of increasing cost of land and allow developers and contractors to realize (despite this development) buildings to reasonable cost as well as own return on investment.

Based on the analysis, categorization and explanatory study of the principles for ROD (introduced by Bock in 1988, and later forming the basis for the development of integrated automated construction sites by major Japanese contractors from 1990 onwards) have been taken forward, and methods and approaches have been suggested for an R&D strategy that would allow the realization of the suggested manufacturing technology for construction sites.

As part of his work as the Chair for Building Realization and Robotics at Technische Universität München, the author contributed to, coordinated or set up three large university-industry research consortia (GEWOS, 3.5 million euro project, LISA, 1.2 million euro project, PASSAge, 3.9 million Euros project cost; for further details, see **chapter 8**), in which complex technological solutions were developed and prepared for market. Furthermore, the author of this thesis during 2009, 2010 and 2011 was a member of a working commission of the Ambient Assisted Living (AAL) funding program and supported the German Ministry with studies in the strategic orientation of the program. Through both the contribution to research projects and the AAL program, the author of this thesis became familiar with concepts and techniques of systemic innovation generation and management, and was able to build up knowledge that was subsequently utilized in the research conducted for this thesis, and which served as basis for the identification and evaluation of approaches presented herein. The functioning interaction of interdisciplinary research consortia, universities, companies and funding structures is considered by the author of this thesis as crucial for the subsequent and incremental implementation of the suggested, necessary manufacturing technology in construction.

This thesis, representing the relevant research steps, is structured as follows:

- **Chapter 2 - Introduction of Relevant Terms, Concepts and Technologies:** The terms, concepts and technologies relevant to the understanding of the approach of setting up Automated/Robotic On-site Factories and the evaluation of concepts and parameters are introduced. The area of knowledge considered as relevant for the field covers the following aspects: productivity, efficiency and economic performance (see **2.1**), modularity (see **2.2**), technology and organization in manufacturing (see **2.3**) and automation and robot technology (see **2.4**). As the approach to Automated/Robotic On-site Factories is a highly interdisciplinary field that requires adapting knowledge from various fields (robotics, mechanical engineering, electrical engineering, management, and informatics) into the architecture and construction fields, relevant concepts and technologies have been analyzed and introduced.
- **Chapter 3 - Off-site Technologies necessary for OEM-like Industry Structure; The Manufacturing Process of Complex Products in Other Industries:** The concepts, technologies and developments in the field of Building Component Manufacturing (BCM, see **3.1**) and Large Scale Prefabrication (LSP, see **3.2**) are outlined. The author of this thesis has conducted several pieces of research (including long-term and short-term research visits to Japan and Korea) and released a multitude of publications prior to this thesis. The author does not consider there to be any evident knowledge gaps in this field and therefore only briefly outlines the concepts, technologies and developments field in the main part of this thesis. However, the field can be considered as relevant for the deployment of Automated/Robotic On-site Factories, as only an advanced BCM and LSP industry can reduce on-site complexity and thus build up the supply backbone in an OEM-like industry structure, which can be considered as a prerequisite for the implementation of Automated/Robotic On-site Factories. In the same manner, a brief comparison of the manufacturing systems of other relevant

industries manufacturing complex products was conducted (see **3.3**). Tunneling, shipbuilding and aircraft manufacturing have significant similarities in terms of product structure, manufacturing strategy and manufacturing systems to the approach of automated robotic component integration on the construction site.

- **Chapter 4 - Development of Elementary Technology (Single-Task Construction Robots, STCRs) and Transition to Integrated Automated Sites:** After the first experiments to large-scale industrialized, automated and robotized pre-fabrication of system houses were conducted successfully in Japan, and the first products (e.g. Sekisui M1) also proved successful in the market, the main contractor Shimizu, 1975 in Tokyo, set up a research group for construction robots. The goal was now no longer the mere shifting of complexity into a SE as in LSP, but the development and deployment of systems which were able to be used locally on the construction site to create structures and buildings. The focus initially was set on simple systems in the form of STCRs that can execute a single, specific construction task in repetitive manner (see **4.1**). The fact that STCRs operated task specific made them on the one hand highly flexible (they could be used along with conventional work processes and did not necessitate that the whole site is structured and automated), but also represented a major weakness. As they were in most cases not integrated with upstream and downstream processes, demanded safety measurements and hindered parallel execution of work tasks by human workers in the area where they were operated, productivity gains were often equalized. Above all, the set-up of the robots on-site (equipment, programming) was time consuming and demanded new skills. Furthermore, the relocation of the systems on-site was in many cases complex and time consuming.

The evaluation of the first generations of developed and deployed STCRs and the identification of the above mentioned problems led step-by-step from 1985 onwards to the first concepts for integrated automated/robotics sites (see **chapter 4**). Concepts for Integrated automated construction sites integrated STCRs and other elementary technology as subsystems into and SE set up on the construction site. The development of STCRs, elementary technology, and a concept for structuring on-site environments by ROD was analyzed and supported by Bock from 1984 to 1989 (**Bock, 1988**).

As the development of STCRs, elementary technology and alternatives created the basis for, and paved the way for, the realization of integrated automated/robotic construction sites from the 1990s onwards, the development is reviewed in the chapter. Furthermore, as the development of STCRs parallel to or as subsystems of integrated automated construction sites continued up to today, 140 STCRs have been identified, analyzed and categorized. Furthermore, in this chapter the conceptual and technological reorientation towards integrated automated construction sites, initiated by WASCOR (WASeda COstruction Robot group) and joined researchers of all major japans construction firms and equipment is shown.

- **Chapter 5 - Integrated automated Construction Sites, comparative technical analysis, comparative analysis of productivity, efficiency and economic performance, categorization:** In this chapter 30 approaches to Automated/Robotic On-site Factories have been analyzed in detail (24 on-site factories for construction, six on-site factories for deconstruction). The systems were analyzed systematically according to a technical analysis framework (see definition of framework in 5.1 and detailed analysis in 5.2 and 5.3) and a framework for the analysis of productivity, efficiency and economic performance (see 5.4). The analysis covers following parameters:
 - Evolution Scheme (location of SFs and GFs, general working direction, general work flow)
 - Elevation (detailed vertically organized work flow, Parallel work on various levels, Configuration of main and sub-factories, Analysis of the component installation process)
 - Ground plan (detailed horizontally organized work flow, Configuration of main and sub-factories)
 - Subsystems (on-site factory structure, working platforms, vertical logistics, horizontal logistics, manipulators, climbing mechanism, subsystem modularity, etc.)
 - End-effectors (types of end-effectors, end-effectors modularity), system variations (realized system variations, possible system variations, inbuilt flexibility, changeover ability)
 - ROD (ROD on component level, ROD on building level, ROD on urban level).
 - The analysis of productivity, efficiency and economic performance covers following parameters:
 - Erection speed (project realization speed, FEC)
 - Configuration (technical data speed of equipment, experiments concerning ration of automation)
 - Productivity (productivity workers/time, learning effects)
 - Resource efficiency (products and process monitoring, safety physical strain, weather influence)
 - Usability studies (e.g. Evaluation of usability of on-site factory and equipment by workers/operators)

The data used in this analysis were acquired from various sources, such as company internal project descriptions, publications by companies and their R&D staff, publications by researchers that analyzed systems, by expert interviews with company staff and by site visits. Furthermore, as a basis for the analysis served documentary material in the form of plans, project descriptions and a picture archive of the Chair of Building Realization and Robotics that documents the application of nearly all systems. Based on the technical analysis a categorization framework was developed which considers the building typology, the location of the on-site factory and its general working direction. The categorization framework not only classifies the analyzed approaches (eleven main categories) but also gives an orientation framework for future developments by showing which types of approaches are feasible for constructing a

certain type of building. Based on the analysis of productivity, efficiency and economic performance it was concluded that improvements compared to conventional construction were significant but not significant enough yet to justify the development of such a complex and cost intensive technology.

- **Chapter 6 - Explanatory Study of Approach to Real-time and Building-integrated Automated Construction; Principles of ROD:** In the former chapter it was shown that, on the one hand, that basic concepts and technologies have been developed and can be carried on, and, on the other hand, that for large scale deployment more radical solutions and co-adapted change of manufacturing, technology, organization, product and associated business models are needed. It was shown that the current generation of automated construction sites are, on average, able to achieve improvements in terms of productivity and efficiency of about 50% compared to conventional labor-intensive construction methods. Relative to strategies that aim at better management and organization of the conventional labor-based construction industry, the gains in productivity and efficiency are enormous. Relative to other industries that manufacture complex products and the force multiplication, productivity and efficiency achieved in those industries (see 3.3), a 50% gain in productivity/efficiency is low. This is reflected further by the fact that the current generation of automated construction sites has not yet reached the level of economic feasibility. The resources necessary to develop and deploy these systems outweighs the considerable but not yet high enough gains in productivity and efficiency. Nevertheless, the basis for the multiplication (not only marginal improvement) of productivity and efficiency can only be built by the consequent emphasises of technology and a maximized reduction of human labor on-site.

In this chapter, therefore, an approach is presented which builds on the idea of automated on-site construction but advances the idea and relates it to the idea of LSP (and in particular unit based prefabrication) in order to form a continuous manufacturing chain (see 6.1). In an exploratory study, a system was developed which would not only improve (e.g. as the above motioned management approach) or double productivity, but which would be able to multiply performance. A technological system is proposed which is in tune with actual and future technological developments and which has the ability to be continuously advanced in the future. The general idea of the approach is the installation of a system on the construction site that allows a continuous and uninterrupted assembly of customized building blocks on the construction site to a (high-rise) building. The target system follows following main principles:

1. Uninterrupted and production-line-like material flow on-site
2. Consequent easement of *any* idle time on the construction site
3. Maximum reduction of on-site activities and activity complexity
4. Maximum reduction of on-site construction time
5. Extensive use of modularity and self-adjusting/ fast connector technology

Furthermore, it will be explained how ROD can support efficient research, development and deployment of automated/robotic construction (see 6.2).

- **Chapter 7 - Roadmap to Economic Feasibility of automated Construction; R&D and funding strategy, Acceleration of strategic and technological development by systemic innovation; Reverse Innovation.** In this chapter it is first discussed, that the achievement of economic feasibility of automated construction will be a key issue for future development phases and that a targeted funding project could minimize the risk for companies in a transition period from conventional to automated construction (see 7.1). The economic feasibility of automated on-site construction up to today has not yet been the focus of R&D activity in the field. The LSP industry in Japan achieved economic feasibility from the end of the 1970s onwards in the housing market and was from then on not interested in developing its technology further, or advancing to other markets than the housing market. The first wave of R&D in automation and robotization of on-site processes by STCRs was concerned primarily with the analysis and imitation of construction processes and the technically focused development of elementary technology. The second wave of R&D from 1985 on which intended to network elementary technology to integrated automated sites was mainly concerned with the aspect of integration and its implications on the construction process, building component structure and design. Based on the analysis conducted in chapter 5, the explanatory study presented in chapter 6 and the setting up of a roadmap to economic feasibility, a funding program strategy is suggested that would allow the instant and/or near future deployment of on-site factories.

As stated earlier it is important that a novel attempt to automation in construction reaches economic feasibility and technological robustness faster than the systems developed during the 1990s in Japan. Therefore, further in this chapter innovation mechanisms and technology transfer strategies are analyzed and adopted to the suggested approach for real-time and building-integrated construction (see 7.2). The suggested mechanisms allow in terms of time, resources and financial input efficient build-up of strategies and technologies necessary to deploy Automated/Robotic On-site Factories. Furthermore, it is shown that the overcoming of the challenge to develop and deploy Automated/Robotic On-site Factories could finally generate novel concepts and technologies for the manufacturing of complex products which could be of significant interest for other industries (see 7.4).

- **Chapter 8 - In the Conclusion the Most Important Findings of the Thesis are Summarized.** It is concluded that basic concepts and technologies for automated robotic on-site factories have been developed, and that the approach would be able to replace the currently underdeveloped machine technology in construction, and allows for integration with and unfolding of the potential of development for example in the field of Computer Aided Manufacturing. Through integrated flexibility (for example reprogrammability, multiple DOFs of subsystems and manipulators), changeover/modular flexibility (modularity of subsystems, modularity of end-effectors), the existing approach already integrates characteristics that would allow improved for

flexibility and variety – even if conceptually and technologically. However, large-scale deployment and economic feasibility necessitate novel and more radical approaches and a consequent co-adjusting/synchronization of products, management strategies and business models. Coordinated R&D, funding strategies and innovation and technology transfer methodologies have to accompany the development of novel approaches in order to support their advance to marketability.

Roadmaps for possible configuration of future on-site factories, the products, management strategies and business models and for coordinated R&D, funding strategies and innovation and technology transfer have been developed and outlined in this thesis. The thesis thus presents an approach which is able to close the technological gap identified and shows methods for the realization of this approach. Future research will focus on the set-up of interdisciplinary research consortia (for example similar to those set up for the projects GEWOS, LISA and PASSAge in the Ambient Assisted Living field to which the author of this thesis contributed) that form value systems able to transfer the approach into the market.

- **References:** In this section literature from which information has been obtained of which influenced the work conducted as part of this thesis is presented.
- **Additional Research Documents Part:** An additional research documents part completes the above introduced chapters and gives prove of the analysis conducted as part of this thesis. In order not to disturb the flow of argumentation in the main part, detailed analyses are outlined here. Abstracts and summarizations of these analyses were integrated in the main part of this thesis. The additional research documents part details research and analysis in following fields:
 1. Productivity, efficiency and economic performance
 2. Modularity
 3. Technology and organization in manufacturing
 4. Automation and robot technology
 5. Downstream off-site technologies necessary for OEM-like industry structure
 6. BCM in construction
 7. LSP in construction
 8. Manufacturing process of complex products in other Industries
 9. Analysis of productivity, efficiency and economic performance of Automated/Robotic On-site Factories.

As the approach to Automated/Robotic On-site Factories is a highly interdisciplinary field that necessitates adapting knowledge from various fields (robotics, mechanical engineering, electrical engineering, management, and informatics) into the architecture and construction, the additional research documents part will serve later as documents for courses and scripts in teaching that outline basic strategies and technologies necessary to develop and deploy novel ONM systems in construction.

The structure of this thesis is outlined visually on the following page.

Chapter 1

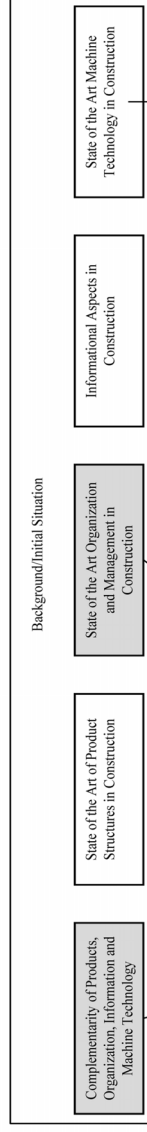

Chapter 2

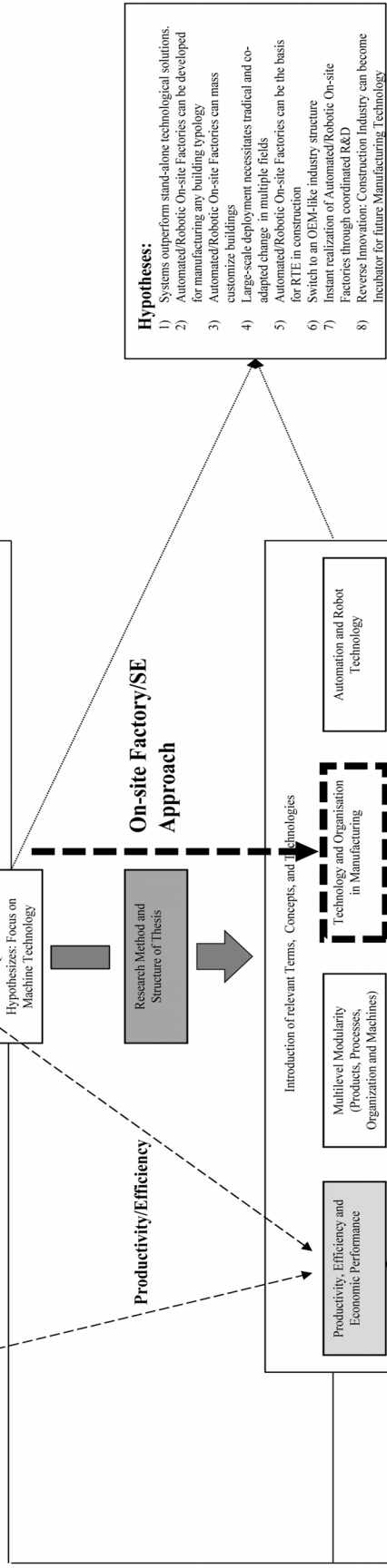

Chapter 3

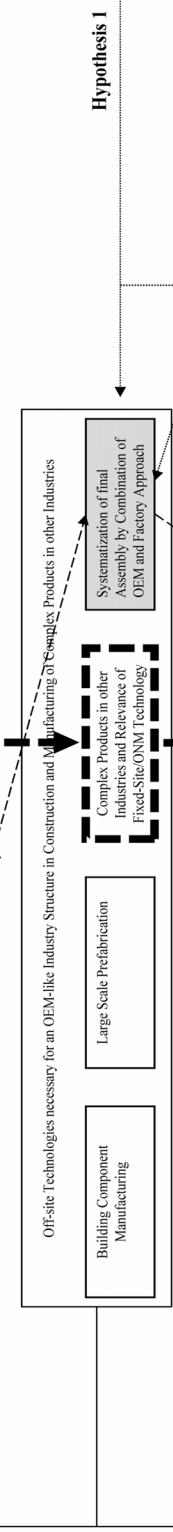

Chapter 4

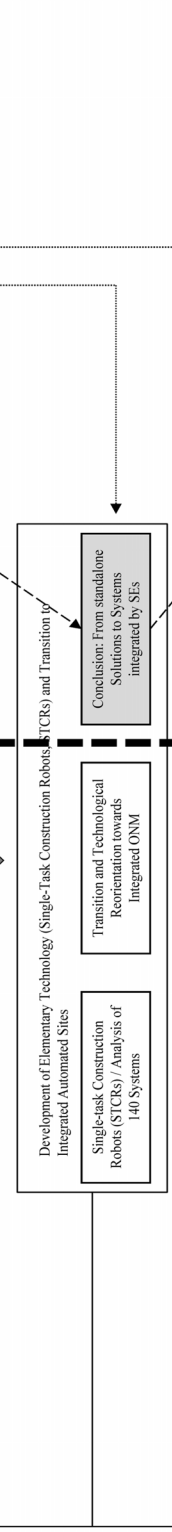

Chapter 5

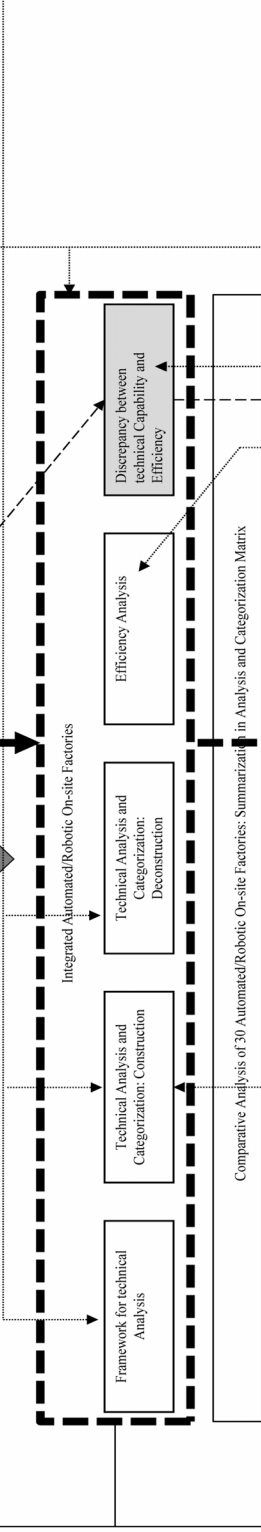

Chapter 6

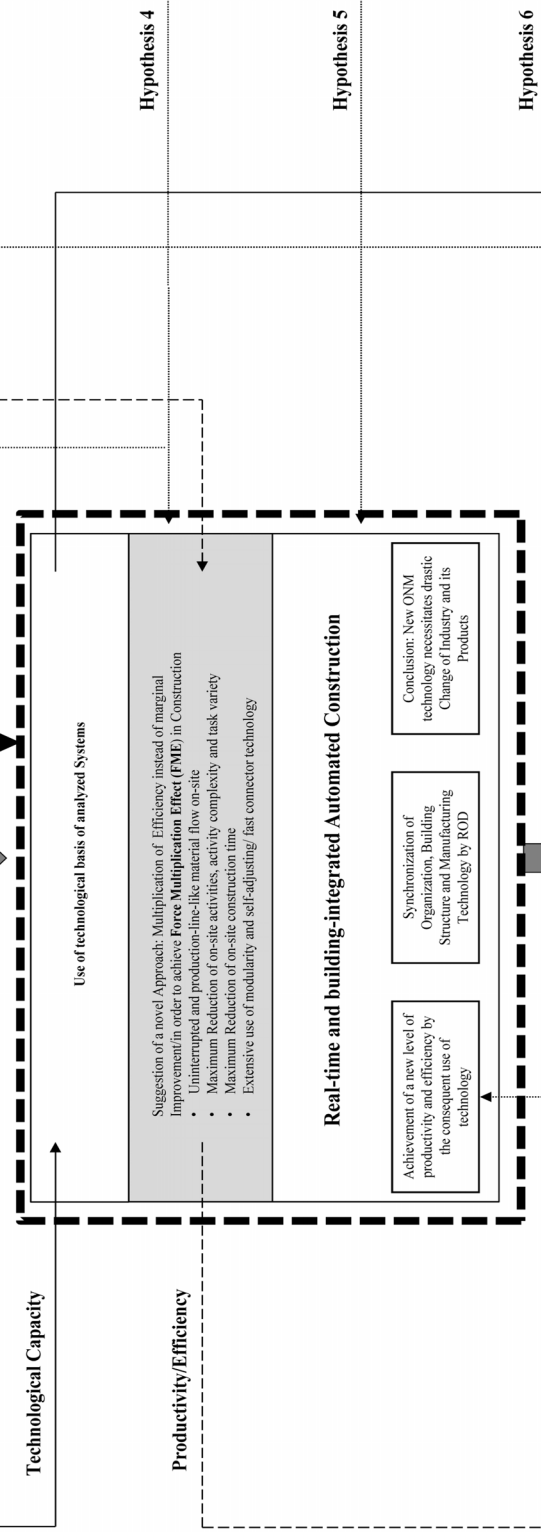

Chapter 7

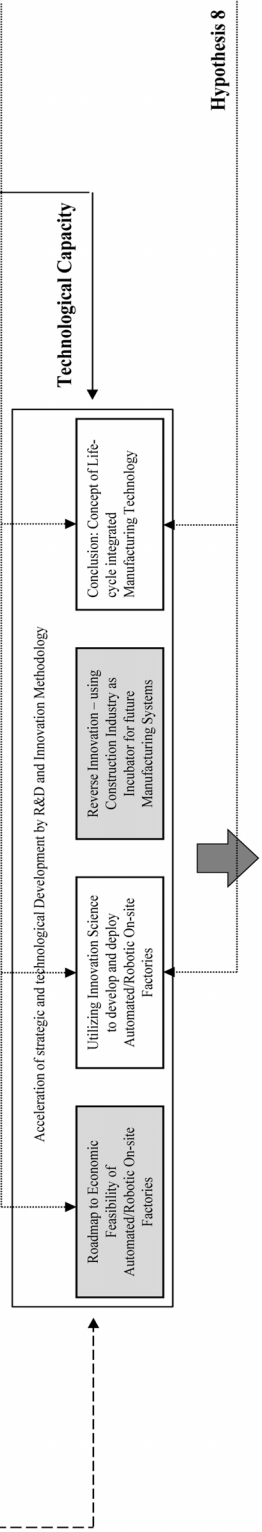

Chapter 8

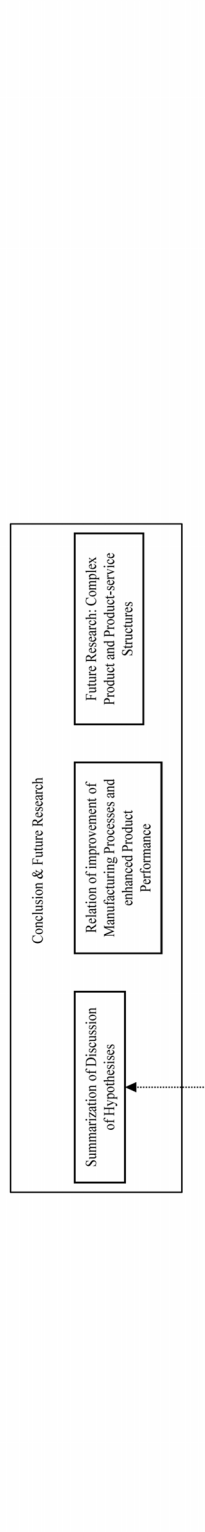

Structure of this Thesis

2 Introduction of Relevant Terms, Concepts and Technologies

In this chapter, concepts and technologies relevant to understanding the approach of setting up Automated/Robotic On-site Factories and the evaluation of related technical, organizational and economical concepts and parameters are introduced. The following areas of knowledge are relevant to the field, and are covered by this thesis, together with the listed aspects:

1. **Productivity, Efficiency and Economic Performance:** organizational and operational structure, means and factors of production, productivity, efficiency, health and safety, economic feasibility; investment, strategy and appraisal; capital intensity (workplace cost); cost of defects in construction, a view on different levels – *overview of the situation in the manufacturing industry generally as well as in the construction industry.*
2. **Multilevel Modularity (Products, Processes, Organization and Machines):** types of modularity, ratio of standardization, platform strategies, modularity and ratio of customer integration, role and design of connectors, integration versus modularity, matching modules and manufacturing systems, F&I strategies; future topic in modularity – *current state of technology in manufacturing industry generally, as well as in construction industry.*
3. **Technology and Organization in Manufacturing:** case studies (Ford, TPS, Smart, Dell, Sekisui Heim, VW, Airbus, etc.), views on manufacturing systems; factory layouts and process design; logistics and supply chain management, changeability in manufacturing (for example inbuilt flexibility, modular flexibility), important technical terms, environmental and social dimensions of manufacturing; future concepts - *current state of technology in the manufacturing industry generally, as well as in the construction industry.*
4. **Automation and Robot Technology:** definitions of machines, automation and robotics; facts and figures, industry development, robot composition and kinematics basics, sensors & actuators, end-effectors, modularity in robotics, human-robot cooperative manipulation, robotic logistics; future concepts – *current state of technology in the manufacturing industry generally, as well as in the construction industry.*

As the approach to Automated/Robotic On-site Factories is a highly interdisciplinary field that requires the adapting of knowledge from various other fields (robotics, mechanical engineering, electrical engineering, management, and informatics) into the architecture and construction field, relevant concepts and technologies were analyzed in detail. In the

following sections the relevant aspects are briefly overviewed and the relevant terms, concepts and parameters are introduced.

Within each field of knowledge, the *current state of technology in the manufacturing industry generally, as well as in construction industry*, is referred to. Further concepts, technologies and developments being relevant for highly flexible manufacturing settings (e.g. inbuilt flexibility and modular flexibility of kinematic main structures and end-effectors, open source, fast re-programmability, cellular approaches, etc.) that allow for product individualization in general and/or industrialized customization in the construction (e.g. in off- or on-site factories) have been analyzed within each knowledge field.

The introduced knowledge fields also serve as a basis for the set-up of frameworks for analyzing manufacturing technology in BCM (see **3.1**), LSP (see **3.2**), non-construction industry (see **3.3**), STCR technology (see **4.1**) and Automated/Robotic On-site Factories (see **5.1**, **5.2**, **5.3** and **5.4**). Throughout the chapter, in particular, the relevance of the introduced terms, parameters, concepts and technologies for the Automated/Robotic On-site Factory approach being the focal point of this thesis is highlighted.

Although impulses for advanced technologies and organizational forms currently come predominately from non-construction industries, in nearly all manufacturing related aspects introduced in this chapter, approaches for mechanization, automation and robotics in construction can be identified. Most advanced construction related approaches are not deployed in large-scale but are breakthroughs by individual firms showing that a shift in construction to a fully manufacturing based industry has potential and is anything but farfetched.

2.1 Productivity, Efficiency and Economic Performance

The analysis of productivity, efficiency and economic performance of new technological solutions for different application scenarios and application scales is key for the general manufacturing industry and helps to determine risk, necessary strategies, resources and the related risks. The deploying of automated robotic on-site factories represents the introduction of capital-intensive technology which requires a major change in the industry, as opposed to the current low-cost labor based construction with its non-specialized and simple multipurpose equipment. Later, the concepts and parameters introduced in this section will be used to set up the framework for the analysis of the productivity and efficiency of Automated/Robotic On-site Factories, which can in most cases be directly related back to its technical and organizational configuration.

Concerning their performance, economically and operationally, factors related to human labor and workforce are not generally 100% definable, predictable and calculable, and thus represent a certain risk for investment and optimization alike. The conventional construction industry relies heavily on the human workforce and in contrast to all other major industries over the last decades even demonstrates decreasing labor productivity. The rise of the percentage of cheap and unskilled labor worldwide, as well as the exposure of the on-site workforce to an unstructured, weather affected, and from an ergonomic perspective, physically strenuous, at times unsafe, inappropriate work environment, influences not only input factors and productivity but also quality. However, the construction industry is currently not only showing poor performance in relation to the means of production (human work), but also concerning the processing of input material (compared to other industries there is a high amount of input compared to a relatively low monetary product output) and concerning equipment (lowest capital cost of all industries and thus lowest value of the used equipment).

Robotic/Automated On-site Factories can, under certain conditions, be an alternative to conventional construction and therefore a solution to the above mentioned problems and tendencies. In order to be able to analyze the productivity, efficiency and economic performance of Automated/Robotic On-site Factories under certain conditions, and to make suggestions for the advance of the Automated/Robotic On-site Factory approach and the introduction of a R&D and funding strategy, relevant terms and parameters are introduced in this section. The parameters that determine productivity, efficiency and economic performance under certain conditions can all be viewed, measured and modified on different scales, which are detailed in *Table 2-1*.

Table 2-1: Parameters determining productivity, efficiency and economic performance.

Parameter Category	Work-task/ machine level	Project/factory level	Firm level	Greater economic level
Organizational and operational structure	Organization and processes surrounding a machine or workstation	Organization and processes in a project or factory	Organization and processes on a firm level	Organization and processes in an industry
Means and factors of production	Factors of production active at a workstation	Factors of production active at a project or factory level	Factors of production active at a firm level	Factors of production available in an industry or economy
Productivity	For example, work productivity related to a single machine or task	For example, work productivity related to a project	For example, work productivity of a company	For example, work productivity of an industry (locally/worldwide)
Efficiency	For example, technical efficiency of a workstation	For example, technical efficiency of a factory	For example, technical efficiency of a firm	For example, potential for technical efficiency in a specific industry
Health and Safety	Accidents and injuries	Increased physical strain decreases productivity	Compensation for construction defects	Cost of damage to health and early retirement
Economic Feasibility	Economic feasibility on workstation level	Economic feasibility of a project	Economic feasibility of firm in a certain time period	Economic feasibility of a greater network of firms or OEM structure
Investment Strategy and Appraisal	Investment in new tools and machines	Investment in new factories	Investment in new factory networks	Investment in new logistics infrastructure
Capital intensity (workplace cost)	Capital intensity of individual process	Capital intensity of a specific manufacturing facility	Capital intensity within a company	Capital intensity of an industry
	Daily basis/short-term	Mid-term	Mid-term	Long-term, e.g. 1 year, decade

Means of Production: Organizational and operational structures can be considered as two different views of a firm’s means of production, namely the structuring and interplay of human workforce, equipment, and material to be transformed. A firm’s transformational process (the transformation of input to output) is created by a specific combination of means of production (factor combination). Means of production can be classified into:

1. Human resources – human activity on different levels (R&D, engineering, manufacturing, sales, management, etc.)
2. Equipment – from owned land down to buildings, factories, machines, robots, tools, fixtures, warehouses, logistics systems, etc.
3. Material to be transformed – raw material, parts, components and other materials that become part of the output product

The specifically applied means of production in each category (e.g. the different types of equipment and human resources on different levels) are referred to as factors of production. Factors of production which fall under the equipment and material to be transformed categories are considered as highly reliable factors, as cost for use as well as the performance of the factor can be specified precisely (**Wöhe, 2010**). Factors of production which fall under the human resources category are considered to be less reliable factors, as human work performance cannot be determined as precisely in terms of cost and output as, for example, machine activity. In general, economically and operationally speaking, factors related to the performance of human labor and the workforce are not 100% definable (*Figure 2-1*), predictable or calculable and thus represent a certain risk for investment and optimization alike.

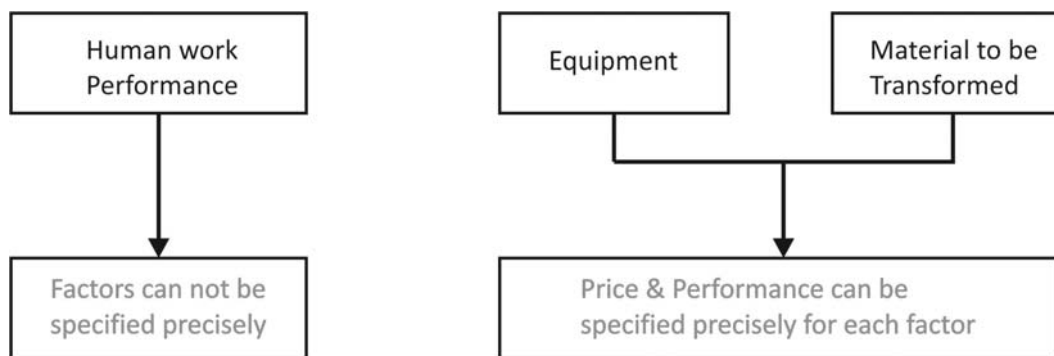

Figure 2-1: Viewed economically and operationally, factors related to human labor and workforce are, concerning their performance, not 100% definable, predictable and calculable and thus state a certain risk for investment and optimization alike.

The construction industry relies heavily on the human workforce and in contrast to all other major industries over the last decades, even shows decreasing labor productivity. The increase of cheap, unskilled labor worldwide, as well as the exposure of the on-site workforce to an unstructured, weather affected, and in terms of ergonomically speaking,

physical strenuous, dangerous, inappropriate work environment, influence not only input factors and productivity but also quality.

Productivity: Productivity expresses and measures quantitatively an input to output relation with a focus on a single (input) means of production or a single (input) factor of production. Productivity can be defined as follows:

Productivity = Output (quantity) / Input (quantity)

The measurement of productivity according to the OECD (2001) is key for the identification of

1. Technological Change
2. Efficiency
3. The potential for cost savings.

Productivity indicators concerning type of factor are:

1. Work productivity – for example, value added or number of produced products per employee in a specific time frame (labor productivity related to value added; labor productivity related to gross output).
2. Capital productivity – for example, return on investment per invested capital amount
3. Material productivity – manufactured product per specified input material amount (e.g. steel input)
4. Resource productivity – more general than material productivity, considers not only the material transformed but also waste, energy, etc.
5. Machine productivity: Machine hours per product or any other specified amount of outputs

Productivity indicators concerning reference parameters:

1. Technical productivity – for example, work productivity expressed in non-monetary output (e.g. amount of produced products per worker)
2. Economic productivity – for example, work productivity expressed in monetary output (e.g. return on investment in Euros) per worker

Due to this focus, productivity can only give an index or a hint concerning possible efficiency, technological change or potential for cost savings, but cannot actually prove the efficiency of a firm, project or manufacturing system. So, for example, while work productivity in a firm could be high, machine and work productivity could at the same time turn out to be low, resulting in an inefficient system. Thus, productivity indices alone are not able to accurately portray economic feasibility or profit ratios. However, it is presumable that a system or firm that is highly productive concerning a specific factor of production, or productive concerning multiple factors of production, is efficient and economically feasible.

An important indicator in the construction industry for efficiency is labor productivity. Moselhi & Kahn (2012) state that the construction industry is highly labor intensive but that

labor productivity has been decreasing over the past 40 years, whereas in the manufacturing industry, labor productivity has improved exponentially. A similar development was identified by the Japan Federation of Construction Contractors in 2012 (Figure 2-2). While labor productivity in Japan in industry overall, and especially in the manufacturing industry, is continuously rising, labor productivity in construction has been decreasing for decades. Labor productivity in construction is not only below average in highly industrialized high-wage countries, but also in emerging economies, for example labor productivity in the Romanian construction industry is considerably below average compared to other industries.

In **chapter 5**, besides the technical aspects, various types of productivity gains accomplished by Automated/Robotic On-site Factories are systematically analyzed. It will be shown that the approaches conducted so far have mainly addressed solely technical productivity and that the gains (depending on the system and the project in which it was applied (in many cases only 10-50%) compared to other industries relying heavily on automation and robot technology were relatively low. In **chapter 6**, therefore, a more radical approach is suggested.

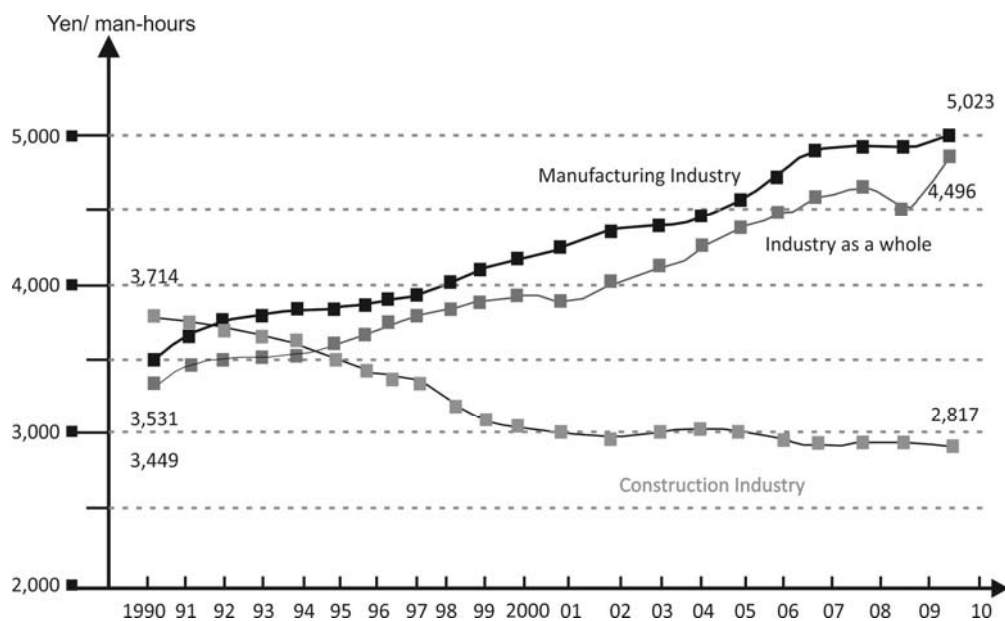

Figure 2-2: Labor productivity in industry generally, and especially in the manufacturing industry is continuously rising; labor productivity in construction has been decreasing for decades. (according to **Construction Industry Handbook 2012, Japan**)

In general (short-term, mid-term, and long-term; task unspecific), the following parameters influence labor productivity:

1. Weather conditions (e.g. temperature, humidity)

2. Coordination/supervision intensity
3. Involvement of various professions/trades and independents
4. Over-manning and congestion of the construction site
5. Equipment
6. Crew size
7. Overtime (as this causes fatigue and accidents, for example)
8. Timing of changing orders
9. Complexity of work-task or work type.

Research has indicated that the timing of changing orders (**Moselhi et al., 1988**), overtime (**Thomas, 1992**) and weather conditions (**Thomas & Sakarcan, 1994**) are highly influential parameters. Moselhi & Kahn (**2012**), on the basis of a comprehensive study on labor productivity in construction, conducted a study identifying and ranking parameters influencing concrete formwork installation. Although the study was task specific, it indicates the importance and relative weight of parameters:

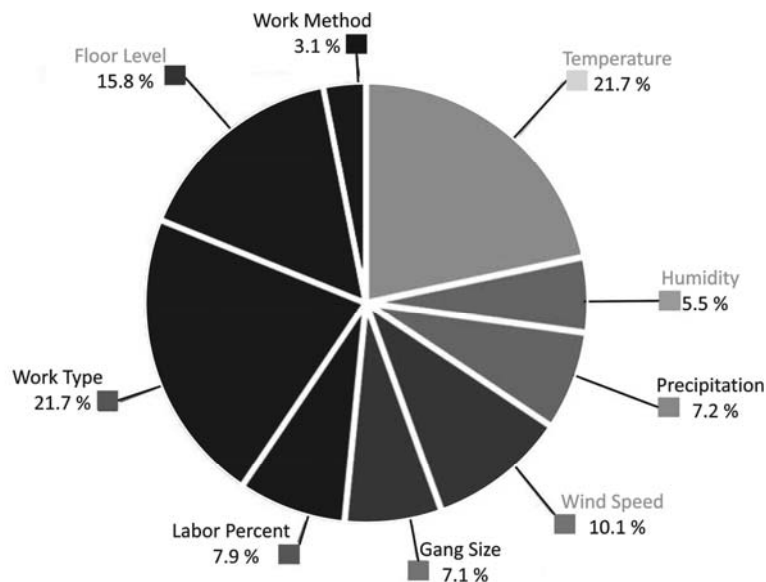

Figure 2-3: Relative weighting of parameters influencing construction tasks on a daily basis - concrete formwork installation (**Moselhi & Kahn, 2012**)

Figure 2-3 shows that only with the introduction of a covered site (which has been introduced by most on-site factories, see 5.2) major parameters that obviously influence productivity (floor level, temperature, humidity, Wind Speed) can be addressed. Furthermore, the use of automated/robotic subsystems allows additional parameters to be influenced and adjusted by the available workforce (work method, work type, gang size).

Efficiency: Whereas productivity expresses an input to output ratio with a focus on a single factor of production, efficiency considers multiple factors and their combination. Productivity can be an indication for efficiency, and efficiency itself for economic feasibility. Efficiency can be defined as the relation between an achieved result and the input combination of factors of production (ISO 9000:2000). Herrero & Pascoe (2002) define efficiency as the result of an optimal combination of input factors. The following type of efficiency can be identified:

1. Technical Efficiency – optimization of input factor combination to generate a (non-monetary) amount of output or products.
2. Allocation Efficiency – considers not only the optimization of the factor combination but also the individual process of the factors
3. Economic Efficiency – technical efficiency and allocation efficiency are a pre-requirement for economic efficiency

Although the projections for product related costs for input material in industries are much higher on average than the cost for personnel (in Germany, the cost for material input accounts for 35-45%, the cost for personnel account for 22-35%; (**Institut der deutschen Wirtschaft in Köln, 2012**), the improvement of work productivity and work efficiency has dominated activities over the past few decades (**Baron, et al., 2006**). However, since 2009, resource efficiency in manufacturing and production has become a major topic for the European manufacturing industries, as well as for their equipment suppliers. On a national (BMBF) and international (EU FP7) level, since 2009, several hundred million euros of research funds have been distributed with the goal of improving the strategic position of companies in the field. Resource efficiency in manufacturing covers the following topics:

1. Reduction of input material that becomes part of final outcome - can be achieved either by material savings or by recycling
2. Reduction of additives (e.g. welding consumables) – can be achieved either by material savings or by recycling
3. Reduction of energy consumption by reduction of energy consumption of machines or manufacturing systems
4. Reduction of energy consumption by process improvement (e.g. reduction of idle times, storage, etc.)

In order to enhance resource efficiency, both an economic design of the product and the transformational process that generates the product hold potentials and are often closely or synergistically related to each other. The concept of ROD (discussed in detail in **6.2**) shows how those aspects can be unified and implemented within Automated/Robotic On-site Factories.

The Construction industry has a low productivity of raw material input (**Wimmer, 2009**) and about 40% - 50% of raw materials globally are used for the construction of our environment. The above figure shows that the consumption of raw materials related to the construction industry (construction materials) in the USA since 1950 has tripled and still is

on the rise (Figure 2-4). Later on, it will be shown how Automated/Robotic On-site Factories are able to address issues related to resource efficiency in a much more convenient way than conventional construction through structuring on-site work environments and integrating them with OFM, deconstruction and re-manufacturing approaches.

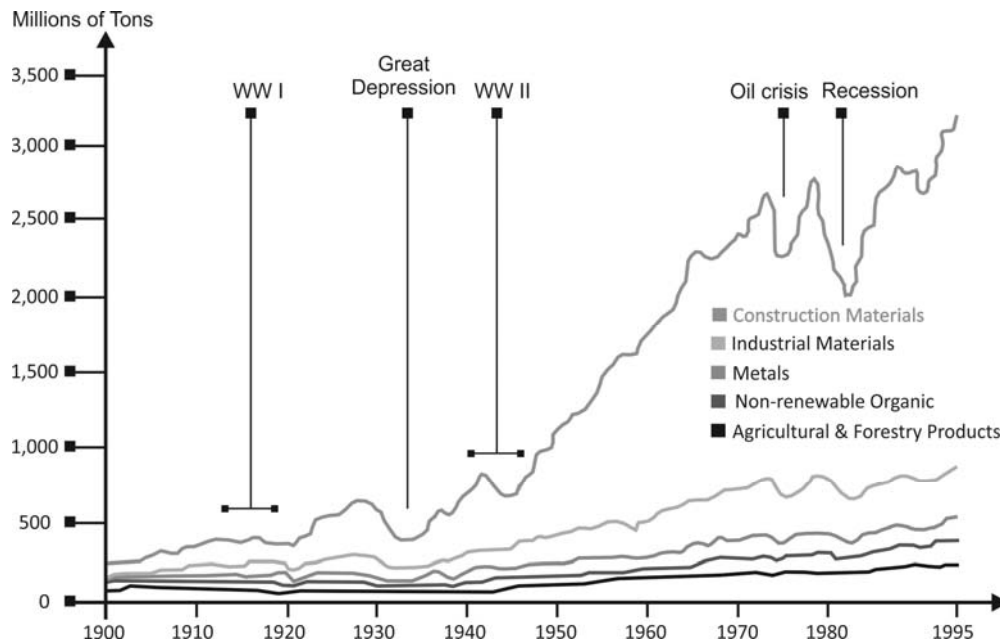

Figure 2-4: Raw Material Consumption (short tons) in the United States 1900-1995 (on basis of U.S. Geological Survey Institute, **USGS, 1998**)

Health and Safety: Health and safety issues are often neglected in construction, and their monetary and non-monetary impact in relation to injuries and fatal injuries as well as their impact on productivity, efficiency and product quality are underestimated. However, in this section we will show that it influences the four main parameters of construction management (quality, quantity, cost and time) and moreover brings tremendous costs to social security and public health systems. Furthermore,, the long-term impact of the poor image and social reputation of construction work is leading to a steady decrease in skilled labor that is hard to foresee and is likely to further decrease productivity and quality in the construction industry. In the German construction industry, around 120,000 injuries (2011: 116,686) and around 100-150 fatal injuries (2011: 99) occur yearly (**BG Bau, 2012**). That is an enormous amount, and is even worse considering the fact that the main construction field, where most of the accidents happen, currently employs an average of 715,000 people. Most fatal injuries are caused by excavation and below-ground work, wrongly suspended loads, maneuvering heavy equipment and falls related to facade and roof work. The cost of fatal and non-fatal injuries (excluding losses in productivity and quality, image etc.) is in the billions and has to be borne predominantly by social security systems (the

public) but also by the firms in the form of insurance contributions and temporary compensation of the injured workforce.

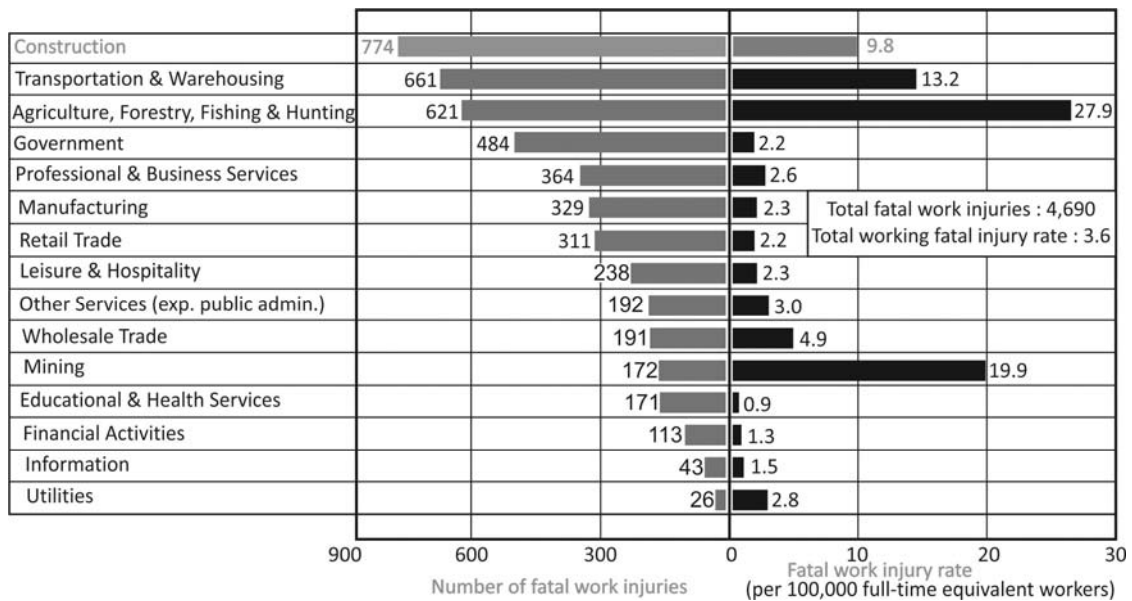

Figure 2-5: Number and rate of fatal work injuries by industry sector, 2010 (on basis of **U.S. Department of Labor, 2012**)

The amount of fatal injuries in construction compared to other industries is shown above by a comparison of the U.S. Department of labor (*Figure 2-5*). As the USA can be seen as a country with a normal and uniform distribution of industries (as is also the case in Europe) the comparison reflects a general, worldwide symptom. Accordingly, construction accounts for the highest number of fatal injuries. It has the fourth highest fatal work injury rate (9.8 fatal injuries per 100,000 workers per year) and can thus be seen as the fourth most dangerous industrial sector (**U.S. Department of Labor, 2012**). Yearly, fatal and non-fatal accidents account for more than 10 billion US Dollars (**Dong, 2005**).

Besides the visible monetary and non-monetary impacts of fatal and non-fatal injuries, health and safety issues influence productivity, efficiency and product quality. Various researchers stress the impact of physical strain (due to physically demanding work and ergonomically critical postures, machines and workstations) on work productivity and the quality of the work conducted (**Ryoo & Chung, 2011, Gatti, 2012**). New technologies that measure vital signs, such as the heart rate or pulse by placing sensors on the body allow for the precise measurement of physical strain and for it to be related back, for example, to work tasks, work hours and thus work productivity (**Migliaccio, 2011**). According to Gatti (**2012**), physical strain leads to fatigue, inattentiveness, poor judgment and thus to a considerable decline in work productivity and the quality of the conducted work. It can thus be said, that it influences the four main parameters of construction management: quality,

quantity, cost and time. By providing a structured work environment which is monitored in real-time, in which robot systems take over difficult and dangerous tasks and which provide safe working platforms, on-site factories are an effective solution for enhancing health and safety on the construction site (analyzed and discussed in detail in **5.4**).

Quality and Construction Defect Rate: As discussed in the introduction, the already high, and still increasing (for more than a decade) number of construction defects can be partly related to poor work performance, lack of skill and miscommunication on the construction site. In Germany, construction defects account for up to three percent of the investment volume in new constructions, and for more than three percent of the investment in renovations. The amount of construction defects is considerable. In the housing industry in particular, the cost for compensation of construction defects accounted for a total of €1.4 billion in 2008 (31 defects on average per housing unit with an approximate defect cost per housing unit of €10,000). The impact of not functioning buildings (e.g. offices or public buildings) on work processes, building down-time and efficiency of the greater economic environment have not yet been included in that statistic. Considering the fact that additional associated costs accompanying the actual defect costs (like cost for lawyers, expert opinions, defect approval certificates, court costs) can account for up to the three-times the actual defect cost, it can be assumed that the actual cost caused by construction defects are between 2-3 billion euros per year – only taking residential buildings with a net dwelling area of up to 2000m² into consideration. Considering all above ground construction (including office buildings and public buildings), DEKRA (**DEKRA, 2008**) calculated and estimated defect costs of about 2.8 billion euros plus associated costs (described above), meaning that the total cost caused by defects is much higher (up to approximately €5 billion).

DEKRA also points out that numerically from 2002, the amount of construction defects rose by more than 100%. On-site factories are SEs in which the systemized work and equipment operation can be recorded and monitored in real time and thus provide a basis for the reduction of defect rates quality and construction to nearly zero.

R&D Spending in Construction: As discussed in the introduction, Despite the above-mentioned organizational deficits, research and development investment (immaterial investment) in the construction industry is among the lowest compared with other industries. On average, German construction companies, for example, only spend €590 per employee for R&D per annum compared to the €30,290 per employee spent by the aircraft and space industry (*Figure 2-6*). The situation in Germany concerning defect cost and low R&D spending reflects the situation on international level (see for example **Construction Industry Handbook 2004, 2010 and 2012, Japan**). The introduction of Automated/Robotic On-site Factories, and the necessary increase in R&D spending in construction will be discussed later. The set-up of a funding program that supports short-term and long-term research efforts could be established to spark the interest of construction firms and automation and robot technology providers to introduce a new manufacturing technology.

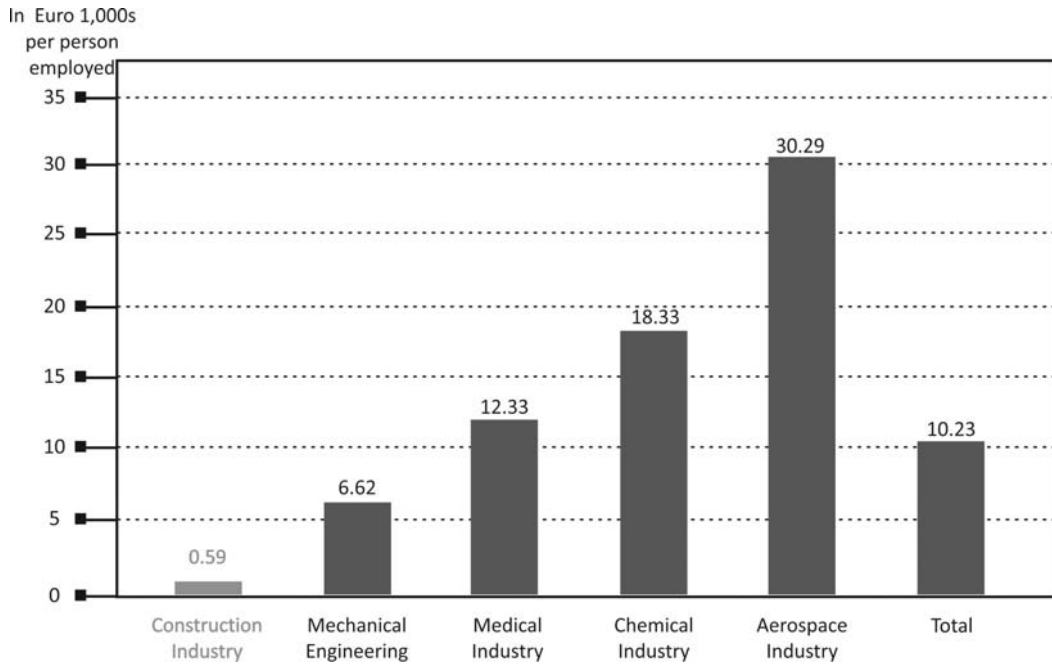

Figure 2-6: Research and Development Investment (in €1,000s per employee in German key industries in comparison (figure according to Züblin, 2003)

Investment Strategy: The above-mentioned departure from the regular, systemized and predictable creation of a product that is currently increasing in conventional construction represents a huge risk for investment, developers, planners and customers. In the development phase, calculations can be performed on the basis of location, intended use and the amount of usable space intended to be created, and investment options can be generated (on the basis of process analysis) and the investment strategy can be set. In order to realize the investment and the intended return on investment, integration along the value chain is necessary so that each phase bears as little risk as possible with respect to derivations concerning quality, quantity, time and cost. Using conventional planning and construction methods, the risk of derivation cannot be reduced to the extent as is usual in other manufacturing industries. However, it will later be shown, that integrated automated construction sites are able to reduce the mentioned risks to practically zero on the one hand, while significantly enhancing construction speed, work productivity, quality and material efficiency on the other (in particular, see an analysis of the efficiency of Automated/Robotic On-site Factories in 5.4 and 5.5 as well as further discussions in 6.1 and 7.1.1).

Table 2-2: The significantly low capital stock and capital intensity, when compared to other industries, is clear (Table on basis of Institut der deutschen Wirtschaft in Köln, 2012).

Capital stock, Capital output Ratio & Capital Intensity *	Year	Capital stock In € billions ¹	Capital output Ratio ²	Capital Intensity In € 1,000 ³	
				Category A	Category B
				Overall Economy	
	1917	2,201.1	2.7	82.9	-
West Germany	1980	3,338.9	3.2	123.8	-
	1990	4,334.6	3.3	152.2	-
	1991	4,537.2	3.1	117.5	105.8
F. R. of Germany	2000	5,457.4	3.3	139.4	139.1
	2008	6,104.0	3.5	151.6	160.8
				Change in % annually	
West Germany	1970-1980	4.3	1.5	4.1	-
	1980-1990	2.6	0.3	2.1	-
F. R. of Germany	1991-2000	2.1	0.7	1.9	3.0
	2000-2008	1.4	0.6	1.0	1.8
F. R. of Germany	2008			According to economic sector	
Overall economy		11,784.6	5.9	292.6	322.0
Agriculture, forestry, fisheries		242.2	11.2	281.5	325.8
Manufacturing industries		1,367.9	2.7	170.4	178.9
Mining		25.1	2.7	310.0	325.6
Processing industry, including:		956.6	2.1	124.8	129.8
Food industry & tobacco industry		99.9	2.2	103.7	110.7
Printing & publishing industry		75.9	2.2	144.6	140.8
Chemical industry		118.3	2.9	255.6	296.6
Metal industry		113.3	1.6	96.7	107.0
Mechanical engineering		94.6	1.3	79.9	81.5
Electrical industry, producing office machinery		114.4	2.2	105.9	106.1
Automotive industry		169.4	2.9	174.1	178.0
Energy & water industry		386.2	7.4	1,374.3	1,474.0
Construction industry		74.7	0.6	34.1	35.4
Trade, transport, catering trade		1,036.0	3.1	103.1	104.3
Financing, rating, company service providers		898.3	2.2	137.1	133.6
Public & private service providers		2,485.0	5.5	204.7	227.3
Dwelling services		5,680.9	25.7	12,403.6	14,175.1

*Annual average values ¹Gross fixed capital, price in year 2000 ²Relationship capital stock to real gross value ³Capital stock per employee **A**: expressed in (year) 2000 prices **B**: replacement cost for workplace

Low Capital Intensity of the Construction Industry: Capital intensity statistics in Germany reflect the above outlined situation in construction. The capital intensity (also referred to as workplace cost) is calculated by dividing the capital stock (assets, devices and equipment used to transform/manufacture the outcome) by the amount of employees in the industry. *Table 2-2* shows, that the construction industry has not only one of the lowest capital stocks (€74.7 billion) but that the capital intensity (and thus workplace cost) is by far the lowest of all listed industries at €35.4 billion. The Automotive industry for example has a capital intensity which is nearly five times that. These numbers clearly reflect the fact that the construction industry has, so far, not used advanced mechanized or automated manufacturing equipment, but has relied predominantly on labor and cheap multipurpose equipment. Above all, the capital-output ratio reveals that the factor combination and the transformation of input to output is inefficient compared to other industries. The construction industry has the only capital-output ratio below 1 (2008: 0.6), whereas most other industries have a capital-output ratio between 2 and 5 (average 2008: 3.5). In 2002, the capital-output ratio of the construction industry was 0.7 (see also **Institut der deutschen Wirtschaft in Köln, 2012**). The decrease of the capital-output ratio correlates with the decrease in labor productivity as well as the increase in construction defects, together with the increase in cost overruns and delays in major projects over the last decade.

Capital intensive methods as implemented for example by the Japanese LSP industry show that productivity could be multiplied and that the construction defect rate could be reduced (e.g. through TPS integrated quality control) to a minimum (**see 3.2**). Similarly automated robotic on site factories are able to reduce the construction defect rate by structuring the construction environment and by real-time on-site progress management (for example, see **5.4**) to near zero.

Studies have shown that capital intensive methods in construction – even in low-wage countries such as Pakistan – can under certain circumstances be more economic than labor-intensive methods (**Paulson, 2004**). Paulson (2004) produced a graph showing the unit production cost rise for capital-intensive methods and for labor-intensive methods with rising labor costs in the industry as a whole (*Figure 2-7*). The graph shows that with rising labor costs, capital intensive methods provide a clear advantage. From the perspective of high wage countries, such as Germany or Japan, they could, given stable or rising labor costs in construction, profit from an enhancement of the capital stock and investment in construction technology.

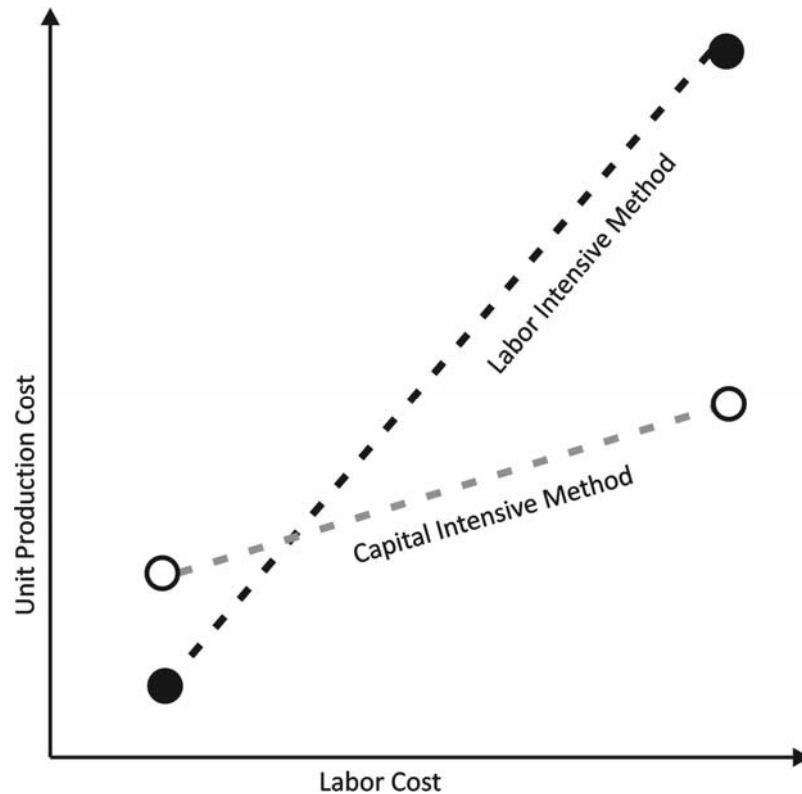

Figure 2-7: Paulson’s graphical analysis of the rising costs when using labor-intensive versus capital-intensive methods in industry (according to **Paulson, 2004**)

However, an increase in capital intensity would also increase workplace costs and thus entry barriers, as well as the necessary expenditures for R&D and innovation. The introduction of Automated/Robotic On-site Factories would require or lead to an enormous amplification of the capital intensity and thus require a complete restructuring of the organizational structure or workforce. A restructuring of the industry and the interrelationship of players in the industry would result. Many capital intensive industries have, over time, converted to an OEM-Tier-n like organizational structure (in particular, see **3.3**). Automated/Robotic On-site Factories (see **chapters 5 and 6**), as discussed in this thesis, would be a capital-intensive method that would address the high labor costs and the availability of technology in developed, high-wage countries; it would, through the set-up of entry barriers, create a competitive advantage.

2.2 Multilevel Modularity (Products, Processes, Organization and Machines)

Modularity plays an important role in the set-up of Automated/Robotic On-site Factories. Modularity comes in to play when the in-built flexibility and re-programmability of the organizational setting, automation and robot technology does not cover the individuality of buildings and their components. Modularity allows, for example, subsystems and end-effectors of Automated/Robotic On-site Factories to be exchanged or adjusted to fit the individual requirements of a building product. Modularity can further be used to adapt future building products to the OEM-like integration structures required by Automated/Robotic On-site Factories. In general, modules are entities that are composed of sub-elements. Sub-elements (if they are not modules themselves) forming a module cannot be clearly distinguished from each other, whereas the actual modules are clearly separable elements. Modules show in themselves rather strong relations of elements to each other, whereas links to other modules are rather reduced and clearly defined. Furthermore, modular systems often refer to systems where individual modules can be adapted, exchanged or recombined – and thus apart from supporting parallelized manufacturing operations, one of the major advantages of modular systems is the evolution capability.

The concept of modularity is used in a variety of industries, however the front-runners in the structuring of highly modular systems are: the computer industry, automotive industry, aircraft industry and the military. In the conventional building industry, modularity has so far only played a minor role and conventionally built buildings are rather “integrated” products. However, in order to introduce advanced manufacturing technologies, automation and robotics, the introduction of modularity in construction is a pre-requirement, as the analysis of Automated/Robotic On-site Factories will later show (see 5.2 and 5.3). The high input of resources (investment, know-how, development time, etc.) needed to create automated and robotized systems needs modularity as a basic element to structure processes, synchronize products with production systems and to guarantee re-usability in multiple projects or over time – and of course to ensure a variety of products.

A helpful way to define modularity is to distinguish between modular and integral products. Modularity can cover the functional reality as well as the physical realm. Where systems can barely be decomposed, both on functional and physical levels, they are referred to as “integral”. If systems can clearly be decomposed both on functional and physical levels, they are referred to as “modular”. In practice, real modularity is still a rare phenomenon in construction and conventional buildings show basic characteristics of integral product structures (for further details, see *Table 2-3*). Japanese prefabricated buildings are modular buildings but integrated Automated/Robotic On-site Factories demand (especially in terms of interface/connector design and dimensions) their own kind of modularity and design of the modular elements.

Table 2-3: Comparison of characteristics of conventional and modular buildings.

Conventional building	Modular building
Integral system	Modular system
Put together from low-level parts or modules	Put together from high-level modules
Parts and modules themselves are manufactured or cut on-site	A major part of the construction work is shifted to factories and suppliers, delivering high-level modules
Construction process - dominated by coordination of professions, but not modules	Production process – dominated by modules.
No clear decomposition of physical elements; no clear decomposition of functional elements	Complex modules might involve various professions working together/cooperating
	Synchronization of physical and functional modularity

On-site machining and assembly centers (on-site factories) process highly complex, prefabricated, components, modules and units on-site – that sometimes even allow a plug and play like installation on-site - as this leads to a reduction of complexity, finally allowing the efficient use of automation and robot systems on-site. An on-site factory functions thus as a kind of OEM that puts together pre-manufactured modules coming from Tier-1 suppliers (see more on this topic from a manufacturing and organisational view in 2.3, aspects of the relevant automation and robot technology are discussed in 2.4). Tier 1-suppliers (e.g. suppliers of facade elements or bath modules) themselves manufacture their modules by the combination of sub-modules and parts from Tier-2, Tier-3, Tier-4, etc. suppliers. In relation to automated construction sites, those suppliers are sometimes company internal suppliers (e.g. both Kajima and Obayashi in the past had their own concrete element factories before concrete elements became commoditized and those businesses were outsourced). To coordinate the integration of parts and components along the value chain, across factories, Tier-n suppliers and their manufacturing systems, the coordinated decomposition of the final building product, and thus the formation of modular systems is essential.

On-site factories demand – especially in terms of interface/connector design and dimensions – their own kind of modularity and design of the modular elements and the modular structure. As no standards or commonly accepted guidelines exist for the modularity needed thus far for automated construction sites, each company that has deployed an automated construction site has developed different modular structures for the building product, as well as for the manufacturing systems. In order to understand the modular structure of products and manufacturing systems of Automated/Robotic On-site Factories, some relevant principles and concepts related to modularity are presented in this chapter.

Outside the construction industry, modularity is already a ubiquitous principle. Interestingly, highly advanced industries with a fast pace of innovation and development, such as the computer industry or automotive industry, are based on highly complex modular systems and methods to advance modularity and modular processes surrounding them. Modularity covers not only the products or services to be delivered but also its production systems (development, manufacturing systems, automation systems, robot systems, end-effectors, organization, processes, etc.).

Types of modularity are manifold and modularity can be described from a multitude of viewpoints. Types of modularity can be defined according to a product life-cycle view, the ability to customize the modular system, to realization steps, to product architecture, to bottom-up or top-down system generation approaches and according to the intensity of hierarchy manifested in a modular system. Advanced modular systems are based on platform strategies and/or F&I strategies.

The modular structure of a product has an impact on all phases of its life cycle: development, planning, production, sales and use/customer. Thus, modularity is an important means of managing the product and control its success over the whole life cycle and overall value-added steps. Various types of modularity can be distinguished according to the product life cycle phase or value-added steps in which the modular arrangement is useful. Generally, one can distinguish between a modularity which serves the planner/manufacturer (producer kit) and a modularity which serves the customer (user kit). However, this simplified classification does not explain how modularity could be used in all life-cycle phases to support related activities. Therefore, the following classification is suggested:

Modularity related to production:

1. Modularity in development
2. Modularity in production
3. Modularity in logistics/ modular sourcing

Modularity related to product use:

4. Modularity in sales
5. Modularity in use
6. Modularity for end-of-life

Modularity in one of the six identified categories can be identical, similar or different from modularity in all other identified categories. A modular structure used in development, for example, can, but does not have to be identical to the modular structure (for example, in production or logistics) – however in many cases it is practical that a modular structure is synchronized with activities in all life-cycle phases, and thus with all of the six identified categories. Later on (**chapter 6**) it will be shown that a synchronization of the structure of buildings over most of the mentioned life-cycle phases would also be advantageous for the

efficient deployment of Automated/Robotic On-site Factories and could, in particular, force future product-life-cycle oriented manufacturing systems.

Interfaces play a basic role in any modular system, as they connect the individual module to each other, whether conceptually, physically or informationally. In complex products in particular, such as cars, aircrafts and buildings, the development of connector systems that robustly connect not only information or simple elements (such as cables, storage systems, etc. in computers), but also physically complex shaped and sometimes heavy or bulky components to each other is a challenge. As part of scientific work as the chair for building realization and robotics, the author has contributed to 3 research projects (GEWOS, LISA, PASSAge; for more details, see **chapter 8**), which targeted, amongst other objectives, modular manufacturing oriented product development and at developing standardized interface and connector systems in construction in order to modularize the infill of buildings (see for example *Figure 2-8*). In **6.1.5** in particular, it will be shown that the development of connector systems, which allow full modularization of buildings and the integration of high-level components by automated/ robotic on-site factories that advance into the role of a final-assembly factory or OEM, are a key element for the realization of approaches discussed in this thesis.



Figure 2-8: Shows a cabinet with removed top plate and sensor infill (system for reading multiple RFID-tags). Each cabinet, and thus its sensor system infill, is connected to the basic wall unit (which also integrates a mini server as “brain”) by a USB connector. USB provides electricity as well as data transfer capability. Connector system developed by the author within LISA.

Modularity can be used to adapt and change products, organizations and manufacturing systems over time. Similar to products themselves, production systems today are modularized. Quickening innovation cycles and the need for adaptability concerning product variants and individual products demand for changeable and reconfigurable manufacturing system and related change strategies. According to ElMaraghy & Wiendahl

(EIMaraghy & Wiendahl, 2009) following types of changeability and adaptability to products and market changes can be identified:

1. **Changeover Ability:** adjustability of a single machine
2. **Flexibility:** refers to a predefined changeability within the constraints of given production system/combination of machines: for example, time schedules, production capacity, throughput time, size of processed modules within the scope of given machinery.
3. **Re-configurability:** In reconfigurable manufacturing systems combinations machines, process modules, process stations and thus organizational patterns can be changed.
4. **Transformability:** Changeability of the whole factory structure and the factory layout
5. **Agility:** changeability of a company and its supplier network

As discussed previously, Toyota, which advanced from a loom producer to a car manufacturer, and now to a home maker with Toyota Home, has demonstrated that companies can, and if they want to survive long-term, need the ability to enter even new product fields with their knowledge. According to Fujimoto (**Fujimoto, 1999**) Toyota has an evolutionary learning capability (see also **2.3**). Another changeability class can therefore be added:

6. **Evolutionary Changeability:** refers to the ability of complete transformation of the company (e.g. from looms to cars)

The changeability of manufacturing systems has several dimensions. It can be considered on various scales ranging from the scale of the individual workstation to the company scale. Furthermore, change can be considered related to different means of production as processes, machines, personnel and management structures, production planning software, etc. Of course in reality a change related to one means of production in most cases also necessitates change of other means. In respect to all these dimensions change of product and production strategies can be realized by a manufacturing system through:

1. **Inbuilt Flexibility:** The manufacturing system has an in-built flexibility and the change in product and strategy can be realized without physical changes (e.g. exchange of systems, workstations, robots, end-effectors, etc.) but by reprogramming the existing system. A standard 6-DOF robot with an end-effector for welding for example has high flexibility and it can be reprogrammed for a variety of welding operations of different products.
2. **Modular Flexibility:** The change in product and strategy exceeds the in-built flexibility and necessitates the exchange of means of production or their rearrangement. Modularity can be generic (predefined process or system modules) or unforeseen (exchange of completely new modules, new configurations).

Change of manufacturing systems is efficient when the product structure is designed in respect of foreseen possible changes and synchronized with the structure of processes,

structure of machines and structure of supply. Current drivers for synchronizing the changeability of product and manufacturing systems are quickening product and innovation cycles, demand for customized and individual products (a key for success, especially in the building industry) and reusability of more and more complex manufacturing technology over several product generations. Both manufacturing strategies and products themselves can be broken down into levels or hierarchies. Six levels on which manufacturing can be viewed can be distinguished (Wiendahl 2002; Westkämper, 2006; Nyhuis et al., 2005). ElMaraghy & Wiendahl (ElMaraghy & Wiendahl, 2009) relate them to 6 product levels and the previously outlined changeability class. In Table 2-4 the relation is represented visually and extended by the changeability class defined by Fujimoto (Fujimoto, 1999) as well as the idea of relating modular structures to hierarchical levels and time levels as discussed above.

Table 2-4: Relation of hierarchical level, changeability class, manufacturing level, product level and time horizon (own interpretation on basis of ElMaraghy & Wiendahl, 2009)

Hierarchical level	Manufacturing level	Changeability class	Product level	Time level
Higher-level hierarchy	Company	Evolutionary/ revolutionary Changeability	Industry level	Decades
	Supply network	Agility	Product portfolio	
	Factory	Transformability	Product group	Years
	Segment	Flexibility Re-configurability	Product	
Lower-level hierarchy	System	Flexibility Re-configurability	Modules	Days
	Cell	Flexibility Re-configurability	Components	
	Station	Flexibility Change-over ability	Parts	Minutes

It can be generalized that different changeability classes (and thus changes on a manufacturing and product level) are related to different time horizons. Whereas a change on a station level occurs on a regular basis, change on a company level has to be viewed on a decade's level. It will be shown later on (in particular, see chapter 5) that

Automated/Robotic On-site Factories can be designed as highly modular systems that can be adapted on lower hierarchical levels (e.g. end-effectors) or on higher hierarchical levels (e.g. factory level: subsystems, configuration, length/width). Through the concept of ROD the modularity of on-site factories can be synchronized with the modular structure of buildings (e.g. ROD on component level, ROD on building level, ROD on urban level; analyzed in **5.2** and **5.3**, and discussed in particular in **6.2.11**) allowing the on-site factories to be efficiently adapted from project to project to enable various buildings to be constructed. Through the combination of inbuilt-flexibility (e.g. re-programmability, workspace of manipulators, inbuilt dexterity of end-effectors) with modular-flexibility as described above, on-site factories function as highly flexible manufacturing cells.

2.3 Technology and Organization in Manufacturing

With the introduction of Automated/Robotic On-site Factories, organizational forms on the construction site, as well as in upstream and downstream value-added steps, have to be changed as in any other industry when new machine systems are introduced. In order to be able to understand those changes, to explain parameters that will later be analyzed, and to advance the Automated/Robotic On-site Factory approach, relevant technology and organizational aspects in manufacturing will now be introduced and explained.

Manufacturing strategies and systems are evolving and, due to changing economic requirements, new strategies, processes and subsystems are continuously being invented and added to or being combined with existing ones. Reasons for change are manifold, however, changing demand in terms of variety (or customization) and novel manufacturing technologies are the main drivers. In 1915, Ford, for example, delivered only one Model in one color (Model T), whereas in 2005 Ford delivers more than 60 models with a huge amount of variations for each model. New manufacturing technologies allow human beings and technology to be combined into highly flexible and efficient manufacturing systems. Automation and robot based systems can now be so flexible that they are able to manufacture individual customized products with nearly the same efficiency of mass production.

Ford's concepts were advanced step-by-step into more demand and customer oriented manufacturing systems by the TPS, Smart's Production System and Dell's Production System. Toyota Home and Sekisui Heim transferred OPF concepts to production-line based manufacturing of customized buildings. VW (Volkswagen) with its manufacturing of customized Phaeton Cars has gone one step further and uses human beings as a flexible assembly system that is backed by a completely automated logistics and parts/component delivery system. The manufacturing of the Airbus A380 (see **3.3.3**) and Kajima's AMURAD (see **5.2.4**) clearly show that the above described manufacturing technology and organization can be adapted to the fixed or on-site assembly of highly complex customized products. The advance from mass production over-demand oriented approaches and factory based (off-site) customized production to customized fixed site (on-site) production can be considered as a step-by-step development. Although this evolution cannot be fully covered within this thesis, and being aware of the fact that manifold inventions and trials contributed to it, important steps in this evolution are highlighted by giving representative examples.

The ideas and organizational forms of the TPS diffused in Japan in the 1970s, 1980s and 1990s into almost all industries. Toyota itself transferred the TPS into the construction industry by applying it within Toyota Home to the production-line based LSP of individual buildings (see **3.2**). TPS principles served also as the basis for the organization (set-up, material flow, strictly phased component on-site assembly by equipment, flexibility, etc.) of Automated/Robotic On-site Factories from 1989 onwards (see also **4.2** and in particular **chapter 5**). Already, from 1985 onwards, the application of TPS principles was being

discussed within WASCOR and other working groups in the transition phase from STCR applications to Automated/Robotic On-site Factories (for further details, see 4). The advance and implementation of TPS principles further formed the basis of the approach for real-time and building integrated automated construction, which is discussed in 6.1.

The TPS is not a counter concept to Ford's production system, but a logical and consequent advancement of the concept of mass production to a more flexible and adaptive form of production. Ohno, the supervisor of the implementation of TPS at Toyota explains in his book about TPS that the foundation for the system was laid by Ford's production system (Ohno, 1978). Ohno and other Toyota engineers after the Second World War studied the production systems of US automotive producers and then fused it with Japanese strategies and technologies (Shingo, 1982). Basic elements of the TPS, such as the principle of continuous flow of materials and products and a high level of intelligent and adaptive automation could already be found within the Toyoda Automatic Loom Works, the parent company of Toyota Motors Corporation, which was officially founded in 1937 as a spin-off and which today is the main business of the Toyota Corporation.

1. Principle of Continuous Flow of Materials: Toyota Loom Works was already more focused on connected sequences of machines and processes than on single high performance systems. Machines of Toyota Loom Works not only focused on looms but provided a solution for the automation of the whole process chain from raw wool processing to the weaving process. This principle of continuous, smooth and uninterrupted flow of materials is also one of the main concepts of the modern TPS. It allows for waste in the form of stock and resting materials to be erased. In the final assembly lines of Toyota Motors and Toyota Home, the products to be finalized are continuously moving with the effect that human beings (seen as part of the production system) are also continuously moving. The principle of the continuous flow of material, together with the idea of reducing stock and associated costs has led to the idea of a JIT and JIS organized factory (internal) and connected factory (external) logistics and material flow.
2. Principle of Intelligent and Adaptive Automation: The principle of intelligent and autonomous automation is one of the main reasons for the high labor productivity that Toyota achieved after the full deployment of TPS in the 1980s, compared to the productivity of US automotive companies, such as GM. Ohno analyzed the processes and machines of the US automotive companies and found that many complex machines still had to be supervised by a human worker in order to maintain the quality of the products (Ohno, 1978). TPS then built systems into machines that could work to a high degree of autonomy and were equipped with a multitude of sensor systems, reducing the need for human supervision, automation and robot technology. This strategy is often presented as having been introduced by TPS. However, it was a strategy whose foundations had already been laid by Sakichi Toyoda and the inventions he made for the textile industry. Until 1924, under his guidance Toyoda equipped looms with automatic shuttle loaders and systems that could automatically detect irregularities, thus reducing the need for human supervision. Then, in 1924, Toyota's loom Type G

Automatic Loom became the first loom with a proprioceptive (mechanical) sensor system that could stop automatically in the case of malfunction during weaving and thus erased the need for supervision completely. The invention was later licensed to the UK and the money received for the license formed the basis for building up Toyota's automotive section.

3. From Push to Pull: One of the main ideas of the TPS was the shift from mass production that produces, in terms of components and final products, in-stock (pushing production) to a new form of production that produces on-demand (pulling production). TPS adopts the mass production approach of splitting up the production into main lines and sub lines as pioneered by Ford and refined by GM. However, TPS on the basis of the formerly explained concepts (continuous and uninterrupted flow of materials, intelligent automation) reverses the flow of information, meaning that the information about the product is sent to the final production line and from there (by means of *Kanban*) the production systems pull components from upstream process chains (therefore also referred to as "pulling" production).
4. One-Piece-Flow (OPF): TPS also pioneered the concept of OPF, implying that each product on the line is at least slightly different. As stock is minimized or reduced, different products on the production line give internal or external suppliers more time to supply a component. As Toyota, unlike US automotive Companies such as Ford or GM, assumed fast changing markets, it did not follow the strategy of incorporating as many value-added steps as possible (Ford). Rather, Toyota educated their suppliers in the use of *Kanban* and TPS to ensure that they could be embedded fully into their pull and continuous material flow strategies necessary for components to be delivered on demand and JIT JIS.
5. *Kanban* as a means of controlling complexity: *Kanban* was introduced as a system in TPS to reduce the need for detailed top-down production planning. In pulling production with OPF, this would create an enormous control complexity. *Kanban* was originally a simple card system that connected individual work processes. Once a component was, for example, picked or installed on the production line, the *Kanban* was fed back to the upstream process chain where it triggered reordering or rebuilding of the component. Today the *Kanban* principle can also be implemented in electronic form (*e-Kanban*) and many Enterprise Resource Planning tools (for example SAP) have integrated *Kanban* functions.
6. Making Use of the Intelligence and Flexibility of the Worker: From Ford onwards, the task of human workers was continuously simplified and the role of the human beings in the production process was "mechanized". TPS, however, emphasized the strengths of the human worker again, and fully integrated them as an important force in the production system. The strength of the human being, in contrast to mechanical automated or robotic systems (so far), is his flexibility and his intelligence. The "Andon" system refers to the human flexibility and allows the worker to adjust the speed of the production line and to call colleagues for help once an assembly process is too complex

or takes too long – an efficient strategy, especially in a flexible production system with OPF and changing products. The *Kaizen* system means that human intelligence and workers are motivated to make improvements and suggestions for improvement of the processes in the factory in order to continuously improve the production process. Both “Andon” and “Kaizen” integrate the human being as a highly intelligent sensor and feedback system into the production.

7. Fusion of Product and Tool Used to Produce it: Seen from a long-term perspective, Toyota advanced from a tool maker (looms) to a producer of the final product (car). The tool maker knowledge was important for Toyota for development of the TPS, which is not only a production strategy in terms of organization and management, but also requires, for example, the strategy of intelligent automation so that the right tools are developed. With the increasing need to automate production processes in order to increase work productivity, Toyota was able to use and refine its knowledge as a tool maker. It is surely not a coincidence that Toyota was one of the first companies worldwide to use automatic and robotic manipulators extensively from the 1970s. Toyota continues to develop highly customized automation and robot solutions in close cooperation with the companies that develop and provide those Systems for Toyota’s plants. In 1985 Toyota was one of the first companies worldwide that introduced a solution for automatic positioning, adjusting and welding of the body parts to a full car body (Flexible Body Line).
8. Development of Toyota’s own Design Methodology Complementary to its Production System: Toyota, in combination with TPS, developed a design methodology that was intended to optimize design and engineering of cars for the application of its production strategy. Toyota thus pioneered concepts such as DfX and ROD. “Poka Yoke”, “Jidoka” and “Andon” are not only production strategies but require products to be designed to ensure continuous flow of material and assembly errors. Toyota’s TPS compatible design strategy is explained in detail in **6.2**.
9. Continuous Change and Adaptation: The TPS implies the “Kaizen” capability. Kaizen refers to the process of continuous improvement of the manufacturing processes. Those improvement processes can be triggered by suggestions of workers, as well as by engineers or managers. According to Fujimoto, Kaizen as a routine capability on a manufacturing level does not explain Toyota’s capability of disruptive change over longer periods of time (**Fujimoto, 1999**). Fujimoto thus systematically explains that for the first time since its time as a loom manufacturer, Toyota had cultivated a capability that was never explained internally or externally. This might be due to the fact that the acceptance of change is part of the Japanese culture. Shrines, like in Ihse for example, are not preserved but are demonstratively rebuilt within certain time frames to showcase the handover of knowledge. Japanese cities are also an example of fast and continuous change – preservation is not in the mind of any planner of governmental institutions. Furthermore, in the Japanese Shinto religion (a fusion of buddhistic elements and old Japanese nature oriented religions) a positive attitude towards continuous change can be found.

Once construction is seen, as in this thesis, as a manufacturing process rather than a construction process, the principles of TPS, which today form the basis for advanced manufacturing systems around the world, can be fully applied. TPS principles are especially useful for the manufacturing of highly individual products, such as buildings within on-site factories, as it aims at reducing the complexity of final assembly with efficiency of speed and resources.

Analyzing Manufacturing Systems: Manufacturing systems can be analyzed or developed from different views. To characterize more complex manufacturing systems, multiple viewpoints are necessary. Thus, in the additional analysis document section, the most important viewpoints (organizational view, product variation view, order oriented view, location oriented view), which also represent recurring themes in manufacturing, are outlined. Furthermore, factory layouts, process design strategies and logistics strategies and technologies are core themes in technology and organization in manufacturing. Factory layouts are the framework for the arrangement of the means of production (workstations, human beings, tools, storages, supply, logistics, material, etc.), determine processes and material flow patterns, and are thus of especially high importance for the manufacturing of complex physical products. Process design strategies can structure factory layouts on various levels, ranging from the micro level to the macro level (machine level, workstation level, group/cell level, segment level, factory level, network level). Manufacturing layouts and processes are in particular subject to the technical analysis of Automated/Robotic On-site Factories in 5.2 and 5.3.

Logistics and OEM Model: Logistics can be defined as the transport of material within manufacturing systems and supply networks, representing a kind of manipulation of objects by human beings, tools, machines, automation systems and robots (or combinations of those) that position and orientate objects to be transported in a three-dimensional space. However, logistics operations do not change or transform the material directly. Thus, apart from warehouse and storage operations, operations that are not directly adding value, have thus to be reduced or at least designed as efficiently as possible. Logistics operations can be distinguished according to the scale in which they take place (and thus according to the general type of strategies, tools and machines used). Apart from internal factory logistics, external factory logistics and the integration of supply chains, or the integration into supply chains or networks determines the organization of the manufacturing system and the layout of processes on all levels. In industries where highly complex products are manufactured in particular (automotive, aircraft, building) individual components are themselves so complex that a supplier has to rely on other suppliers, leading to the OEM-Model (*Figure 2-9*).

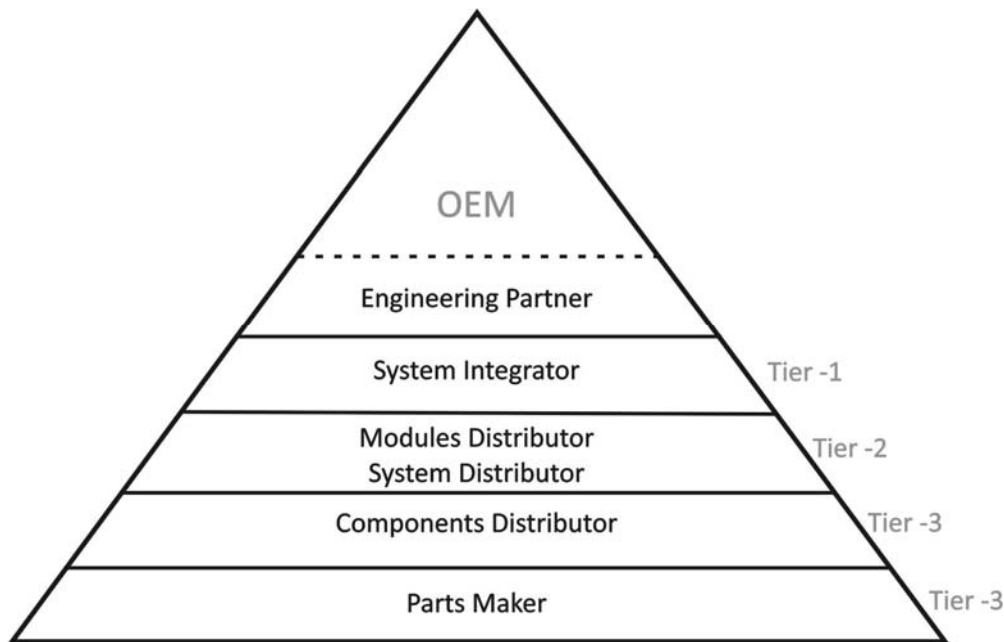

Figure 2-9: OEM Model. OEMs rely on suppliers which are called Tier-n suppliers, according to their rank in the supplier chain. The model explains the general flow of material as well as the flow of information during development of the product and its sub-components (based on **Kurek, 2004**)

According to this model, an OEM relies on suppliers, which according to their rank in the supplier chain are called Tier-n suppliers. A Tier-1 supplier is a first rank supplier which relies on components of Tier-2 suppliers; a Tier-2 supplier relies on components of Tier-3 suppliers and so on. If an OEM performs final assembly then a Tier-1 supplier integrates parts and components for systems. Tier 2 suppliers manufacture modules used in those systems and rely on components of Tier-3 suppliers. Tier-4 suppliers would be equal to parts makers and Tier-5 suppliers are also raw material providers. Formations of Tier suppliers of different ranks supplying a component or system to the OEM are called a supply chain. However, even in the automotive industry, a unique definition of what a system or a module or a component is does not exist, and all major car manufacturers (VW, Toyota, BMW, etc.) interpret those terms differently. Those terms are also interpreted differently in other industries and their individual manufacturers. So, it is best to say that the model represents a general hierarchical structure that can be found today in many industries.

Furthermore, in major manufacturing industries, a development from hierarchical chain structures to more decentralized network structures, and thus a shift from fixed supply chains to more flexible supply networks can currently be observed (see more on this topic from a product structure and modularity point of view in **2.2** and from an automation and

robot technology point of view in 2.4). OEM or OEM-like structures are in this thesis a subjects of analysis and discussion in all following chapters.

Flexibility and Adaptability of Manufacturing Systems: In modern manufacturing and despite the paradigms of demand oriented manufacturing, a decrease in batch sizes and quickening innovation cycles, the changeability of manufacturing systems is playing an increasingly important role. Changeability can be considered on various scales, ranging from the scale of the micro level (e.g. individual workstation) to the macro level (e.g. supply network). Change can be considered in relation to different means of production, such as processes, machines, personnel and management structures, production planning software, etc. Different types of changeability can be realized within the above described scales or means of production, such as changeover ability, flexibility, re-configurability, transformability or agility (for more information on changeability, see 2.2). The co-adaption of changeability of products, processes, organization and manufacturing technology can be realized through inbuilt flexibility or through modular flexibility. The flexibility and adaptability of manufacturing systems is a fundamental element of advanced manufacturing systems both in non-construction industries (for further details, see 3.3) as well as for automated/robotic construction (discussed in detail for STCRs in 4.1 and for Automated/Robotic On-site Factories in chapters 5 and 6).

Swatch pioneered a manufacturing concept based on intelligent modularization F&I strategy that allowed producing fashionable and high-quality watches to reasonable prices on the basis of modular flexibility of the product. After the success in the watch industry, swatch intended to transfer similar concepts to the car industry and consequently, during the 1980s formed a joint venture with Mercedes Benz to develop a cheap, fashionable and “micro” compact car. In the beginning of the 1990s therefore the Micro Compact Car GmbH was founded and in 1996, the Smartville factory in Hambach (France) was opened (**Smart GmbH, 2008**). Micro Compact Car GmbH (in 2003 renamed into Smart GmbH) not only introduced an innovative car but also an innovative manufacturing concept. The TPS can be seen as an important step in the evolution of manufacturing systems to demand oriented pulling manufacturing systems. The Smartville factory followed the concepts and technologies pioneered by the TPS and applied them even more intense. Some even spoke, therefore, of the “smart” revolution in the automotive industry (see, for example, **Radke et al., 2004**).

The Smartville factory connects processes on the basis of its *Produktionsplanungs- und Steuerungssystem* (PPS; in English: production planning and control system) to a demand oriented process “pearl chain” (**Barth & Wollert, 1998**). Furthermore, socio-technical aspects as organized and situation oriented team work is considered in a systemized form. In the factory, a completion of a Smart necessitates 140 work stations, which are completed in 3.5 hours lead time (**Smart GmbH, 2008**). The Smartville factory interprets the integrator role of the OEM in an extreme way and brings the depth of added value realized by the OEM down to 5% (even including adjunct supplier assembly bases and work conducted on the assembly line by suppliers only about 20% of added value is realized within the Smartville factory). The Tier-1 suppliers not only deliver highly complex

readymade components but also install them by themselves on the production line. Furthermore, Tier-1 suppliers are required to develop the components and ensure the integration of low-level components of other suppliers to complete and failure-free high-level components or systems. A McKinsey study states that the reduction of the manufacturing depth is a general and very strong trend in German automotive industry and predicts that the depth of added value by the OEM viewed over all segments (for example interior/instrumentation segment, engine segment, chassis frame segment, car body segment) will be reduced from 35% down to 25% until 2015 (**Radke et al., 2004**). In the engine segment, the impact will be the highest and the depth of value added by the OEM will be reduced down to 9% (today: 24%). According to the McKinsey study, OEMs in the future will provide “Cross-OEM-Platforms” with predefined interfaces and the development of high-level components within certain specifications (including their installation on the final assembly line of the OEM) will be under the responsibility of the suppliers. With a depth of value added by the OEM lower than 15% in total, Smart is already today far ahead of the trend.

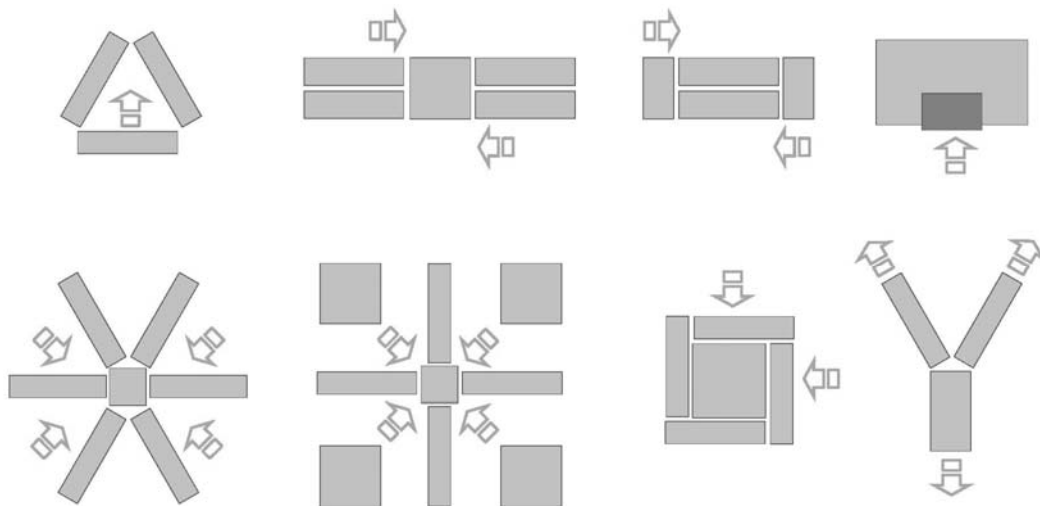

Figure 2-10: Modular manufacturing segments allow for re-configurability of the Smartville factory on basis of modular flexibility (graphical representation adapted and refined on basis of **Block & Greif, 2007**)

Furthermore, the Smartville factory was designed as a combination of modular manufacturing segments that potentially allow a multitude of combinations and thus layouts (**Block & Greif, 2007**) to be generated. In the case products or process change over time or other or new suppliers are integrated into the manufacturing process, the modular factory allows for minor and major changes and extensions of the factory around its central core (*Figure 2-10*). The analysis and discussion of Automated/Robotic On-site Factories in **chapter 5** and in **6.1** will show that a modular flexibility of the factory layout and the

application of an advanced Smartville-like OEM-Model in which the factory on the construction site states the OEM are key to the success of automated on-site construction.

Manufacturing and Sustainability: Besides changeability, environmental and social issues gain more and more importance in manufacturing, influencing technologies and organization alike. The paradigm of sustainability gradually pervades all industrial sectors, all levels of value creation and all aspects of daily life, leading to a new type of industrial revolution, where the importance of environmental and social factors finally becomes equipollent to plain economic efficiency (**Bock, et al, 2009**). Manufacturing systems can be designed to efficiently meet environmental and social issues. Also in construction, industrialized structures and technologies in construction could help to enhance resource productivity, reduce waste, improve safety and working conditions, support the supply of affordable housing and enable deconstruction, reuse and recycling. Both the structuring of off- or on-site factory environments and the switch to demand-oriented manufacturing strategies can reduce resource consumption. Furthermore, manufacturing systems allow for large scale and coordinated energy harvesting, reverse logistics, re-customization and closed loop-resource circulation and thus outperform unstructured approaches. Considering the fact that 40-50% of global raw materials are used for the construction of our environment, the introduction of advanced manufacturing strategies in construction, the introduction of manufacturing technology, and on-site factories hold a potential that goes far beyond the mere reduction of cost, the enhancement of productivity, the improvement of working conditions and/or quality, and the introduction of MC (for more details on the ability of Automated/Robotic On-site Factories and their potential to be sustainable, see **5.3** and **5.4**, and in particular **7.3.3**).

Future Concepts in Manufacturing: Finally, completely new and emerging concepts and organizational forms in manufacturing can be used to augment current manufacturing know-how. Emerging concepts, such as mass-customization, decentralized, miniaturized and mobile factories and personal fabrication are on the increase and have the potential to lead to more and more decentralized, pull-like and customer-oriented manufacturing systems that exceed the capabilities of predecessors such as TPS, Dell and Smart like concepts. Together with approaches that try to link services closely to products and use them for long-term customer relation and innovation creation, it is likely that an era often referred to as the “RTE” can be initiated by those emerging organizational forms in manufacturing. RTE aims at fulfillment of customer demands and requests in near real-time. Products and services shall be processed within a few hours and delivered within days. Companies such as Amazon which process orders immediately and often are able to ship a product that is in stock on the next day already have advanced in the direction of RTE. Future development in the direction of RTE would demand that not only more companies adopt such a model but also that customized and on demand manufactured products that are not in stock but that have to be produced can be delivered within less time as well. On the manufacturing side, the RTE necessitates manufacturing systems that are digitally closely linked networks of manufacturers and suppliers that guarantee a fast flow of materials on demand, and in order to fulfill individual demands modularity, flexibility and interchangeability of manufacturing and supply units that potentially could form different

value networks for different orders. Furthermore, a high degree of automation and autonomy of the manufacturing systems would be necessary. In case a customized product is, for example, manufactured by hand in a low cost economy the translation of the digital information about the product into work tasks and the execution of the work would require several weeks - too much in an RTE. Machines however could start immediately after the order start to produce at high speed on basis of available digital information on which the RTE is based.

In order to be able to cope with fastening innovation cycles and small batch sizes, especially in the field of innovative or customized products, concepts that aim at flexible miniaturized and/or mobile manufacturing systems more and more get into the focus of researchers and developers. In the following, therefore, approaches conducted outside construction industry are shortly outlined. Furthermore, in **chapter 5** and in **6.1**, it will be shown that flexibility, compactness, mobility and the ability of factories to be assembled and disassembled on-site rapidly are key to Automated/Robotic On-site Factories as well.

- Advanced Modular Micro-production System (AMMS): The purpose of the AMMS concept (**Gaugel & Dobler, 2001**) is to provide a manufacturing system kit for the production of miniaturized laboratory and clean room products. As batch sizes as well as component and product sizes become more and more downsized, the capacity of many large factories can hardly be fully utilized and fix cost tend to rise. Large factories also cannot respond fast and flexible enough to innovations. The AMMS kit, however, allows building up customized mini-manufacturing systems that can be used to assemble and inspect extremely small batches of miniaturized opto-electronic sensors or bio chips.
- Mobile Parts Hospital (MPH): The MPH is a self-sustaining and transportable (C-130) manufacturing system developed for military purpose (**Gady, 2005**). It is capable of repairing parts and producing spare parts (on basis of a data base as well as by reverse engineering). The newest version of MPH can even produce completely new parts demanded or invented bottom-up on-site on the battle field. The MPH is synchronized with the standard military container system and thus fully mobile.
- Mobile Field Factory: Within the EU funded international and university-industry cooperative research project Manu Build (the Chair of Building Realization and Robotics, for which the author of this thesis works, was part of this consortium) a ultra-compact and mobile field factory was developed, which allows that building block are prefabricated close to or at the construction site. Both the project and the field factory approach are described in detail by Kazi et al. (**2009**).
- Floating Factories: The oil and gas industry more and more counts on swimming factories. Newly discovered oil and gas reservoirs can increasingly be found in the maritime area. The oil industry thus starts integrating drilling equipment and drilling towers into huge ships, and the drilling equipment stays thus fully mobile. The

processing of oil and gas during the transport turns logistics operations (during which the product usually is not transformed) into a value adding manufacturing process.

- Fab Labs and Personal Fabricators: Gershenfeld (2005) outlines how he started at MIT in the 1980s and 1990s to work on personal fabricators. He draws an analogy between the development in the computer industry (which advanced from mainframes to minicomputers, PCs and today even smaller devices) and the manufacturing industry. Gershenfeld's fab labs were deployed so far in small villages in not- industrialized local areas, where people could on the basis of that technology start to innovate from bottom-up and produce their own specialized and urgently needed goods and devices.

From **chapter 6** onwards, and in particular in **chapter 7** it will be shown that the approach of installing automated on-site factories could be advanced to be in tune with, or even ahead of, the mentioned future concepts in manufacturing.

2.4 Automation and Robot Technology

“The end of the information age will coincide with the beginning of the robot age. However, we will not soon see a world in which humans and androids walk the streets together, like in movies or cartoons; instead, information technology and robotics will gradually fuse so that people will likely only notice when robot technology is already in use in various locations.”

Ishiguro (2012)

Robotic systems are advanced types of machines characterized by capabilities such as re-programmability, autonomy, flexibility and situational awareness. Seeing the advances robot technology is currently making, it is very likely that robot technology will undergo a similar development to the personal computer in the nineties. Now, robots are becoming more user friendly, cheaper, task adapted, smaller, more widely distributed and seamlessly integrated into work processes and devices. One can today acquire modular kits of open source robot hardware and interface robot systems directly to a computer via USB. The transitions between machines, automation systems and robot technology are becoming seamless. Robots are often no longer visible, complex standalone devices, such as the classical 6-DOF industrial robots, but can now consist of a network of interconnected, distributed and sometimes invisible sensor and actuator systems (including, for example, things such as mobile phones or appliances), meaning that individual devices functioning as machines can cooperate as a network to manipulate or achieve goals (for example by manipulating energy flows as smart grids do) autonomously as a robot system.

With the continuous evolution of the field of research, new technical capabilities (modularity, lightweight concepts, wearable robot technology, and social robot technology) have been explored and fused with existing manipulation oriented automation and robot technology. Thus, over time, the ability of robot systems has grown, allowing them to work more and more in comparably unSEs, to those in which human beings operate. This leads to the fact that robot technology, apart from the classical manufacturing industries, can now be introduced and deployed in a multitude of new fields, such as aircraft production, farming, the construction industry (*focal point of this thesis*) and health care sector. New capabilities not only extend the application area of robotics, but also allow robot systems to be used e.g. in factory-like environments, and to become more dexterous and adaptive, thus building a basis for the production of customized and individual products. Faster product life cycles and the increasing demand for flexible production systems able to produce customized products has also lead to refined modularization, plug-and play like capabilities of subsystems, open source approaches, concepts for self-configuring and self-organizing robot systems and cellular robotic logistics.

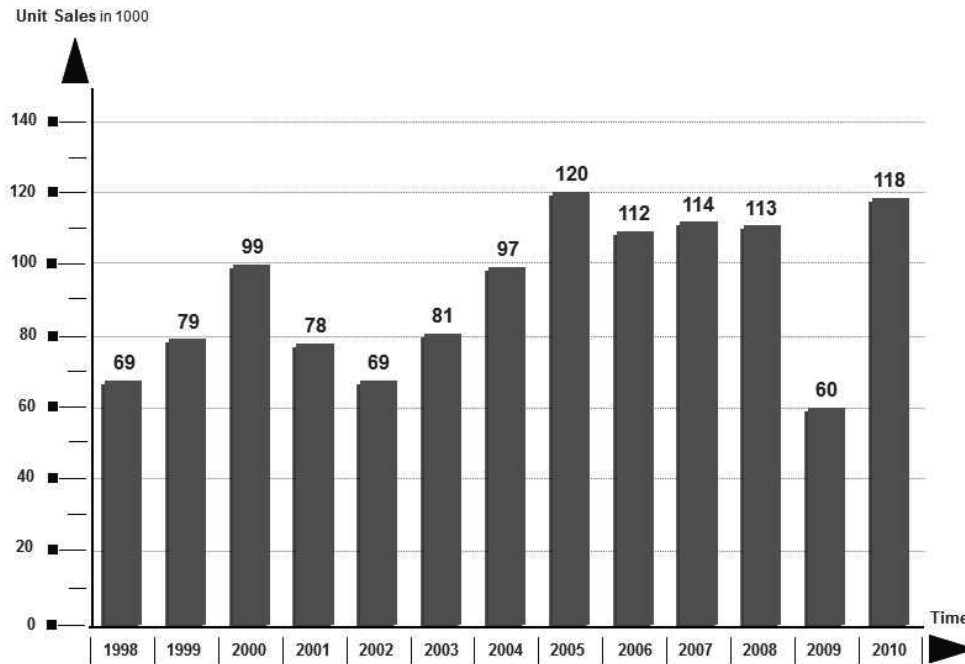

Figure 2-11: The number of industrial robots sold per year has been stagnating since 2005 (graphical representation based on graphic presented in **World Robotics Report, 2011**)

On the one hand the industrial robot sector is stagnating (*Figure 2-11*) and the service robotics field, due to the simplicity of robots to be delivered, is weak in terms of transaction volume and existing demand. On the other hand, the construction industry can be seen as an ideal target market for expansion of the robot market in the short- and mid-term. The construction industry is, in terms of the requirements between the industrial robot market and the service robot market, allowing strategies and technologies to be developed for both markets which could be applied to the construction sector.

If it was possible to structure construction environments, for example by the approach of on-site factories (the focal point of this thesis, in particular, see **chapters 5** and **6**), it would also be possible to apply the robust versions of flexible and dexterous service robot technology currently available or under development. Also, industrial robot technologies already deployed in structured factory environments in the manufacturing industry generally, would then become applicable in the construction industry. In terms of market volume, it has to be considered that the construction sector worldwide is the only major industrial sector remaining which is predominately reliant on human labor, thus providing – once pre-structured and demand has been created – a huge market for automation and robot technology and the associated microsystems and mechatronics components.

Considering that such technologies are the figurehead of leading high-wage industrial nations, distinguishing their industries from emerging industries with low labor cost, it would

be an obvious or almost natural strategy to create a huge novel market for our microsystems, mechatronics, ICT, specialized machine technology, automation and robotics engineers and suppliers within the construction sector. A major goal of this thesis is to discover and advance concepts and organizational forms for structured on-site factories that allow the extensive utilization of such technology to a large scale (see **chapters 6 and 7**).

The analysis of the evolution of machine and robot technology (see also **1.5.1**) reveals that the application of such technology in the field of construction has been seen as obvious and natural at various points in history. Until the 19th century, research in machine technology, kinematics and automation was not separated from the architecture and construction field as much as today. In Japan in the 1970s, during the first robotics boom (**Mathia, 2010**) it was obvious to professionals, companies, researchers and the government that this technology had to be applied in the construction sector as well as in any other industrial sector. This led to the formation of the Waseda Construction Robotics Research Group (WASCOR), the setting up of research institutes and laboratories at Japan's top Universities (e.g. the Laboratory of Prof. Uchida dedicated to "building production" at the University of Tokyo), the large scale deployment of automation and robotics in Japan's housing LSP industry and finally to the deployment of automated construction sites in the 1990s. Furthermore, a "natural" development line leads from Japan's "Karakuri Ningyo" technology (Mechanical Puppets, a pre-form of automation and robot technology, see **Wißnet, 2007** and **Bock, 2012**) – via Toyota's automatic looms, Toyota Motors Corporation and the TPS directly to the (for Toyota) more or less natural application of automation and robot technology within Toyota Home in the 1980s. The application of automation, robot technology and TPS within Toyota Home inspired other prefabrication companies and construction firms to apply similar strategies and technologies during the 90s.

As is usual in other industries relying on automation and robotics, construction can be broken down into a multitude of production and assembly operations, and thus also into mathematical kinematic descriptions of operations. On that basis, automation and robot systems can be composed of combinations of links, joints, actuators, sensors, control concepts and end-effectors that fulfill some or all of that operations by manipulating parts, assemblies and sub-assemblies. Robot composition strategies can be applied to the development of robot-subsystems in general, and also to approaches and subsystems developed for or within the construction industry.

It can be shown that since the beginning of the application of automation and robotics in the construction industry in the 70s, a multitude of construction specific compositions and subsystems have been developed and/or deployed (see analysis of BCM technology in **3.1**, analysis of LSP and its manufacturing technology in **3.2**, STCR technology in **4.1** as well as technical analysis of Automated/Robotic On-site Factories in **5.2** and **5.3**). However, developments for other industries where processes were more structured and automated were manifold and provided a rich ground for the transfer of technology into today's construction industry. Once the construction industry is elevated to a more structured level

(for example, by shifting construction processes to factory environments or by structuring sites through the setting up of site factories as with on-site factories), the range of available automation and robot technology and related production knowledge for the construction industry will be increased significantly.



Figure 2-12: Shimizu's SMART is a modular automated on-site factory with modular robotic (overhead) manipulators and modular exchangeable end-effectors. Apart from the flexibility allowed by modularity, the manipulators and the end-effectors integrate in-built flexibility (for example, through re-programmability)

In particular, concepts, robotic technologies and developments being relevant for highly flexible production settings (e.g. inbuilt flexibility and modular flexibility of kinematic main structures and end-effectors, open source, fast re-programmability, cellular approaches) that allow for product individualization in general and/or industrialized customization in construction (for example in off- or on-site factories) were analyzed by the author of this thesis (see for example Shimizu's on-site factory approach outlined in *Figure 2-12*). The analysis shows that while in the manufacturing industry generally, standard industrial manipulators are widely deployed, in the construction industry (due to factors such as component size and weight) more specialized solutions are required (*Figure 2-13*).



Kuka Standard 6-DOF industrial manipulator



Construction adapted and highly specialized OM used in on-site factories in construction, Shimizu, Japan

Figure 2-13: While in the manufacturing industry generally, standard industrial manipulators are widely deployed, in the construction industry (due to factors such as component size and weight) more specialized solutions are required.

In the following concepts in robotics that are necessary to understand the technical analysis, and to advance the Automated/Robotic On-site Factory approach (presented in **chapters 5** and **6**) which are introduced below.

Kinematics: Kinematics focuses on the study of geometry and motion of automated and robotic systems. On the basis of this study it describes parameters as position, velocity and acceleration of joints, and links and tool center points in order to generate mathematical models building the basis for controlling the actuators. Vepa describes a robot as a kinematic system consisting of a multitude of kinematic subsystems of which the kinematic pair is the most basic entity (**Vepa, 2009**). A kinematic pair consists of two rigid bodies (links) interconnected with a joint (forming the concept of Links and Joints). The following types of joints can be distinguished:

1. Revolute joint: allowing for rotation around an axis – 1 DOF
2. Prismatic joint: allowing for translation along an axis – 1 DOF
3. Spherical joint: allowing for 3-D rotation of a link around a point- 3 DOFs

In a serial kinematic system each joint gives the systems, in terms of motion, a DOF and the type of joint restricts the motion to a rotation around a defined axis or a translation along a defined axis. One key objective of kinematic systems is the manipulation of objects within a geometrically defined space. Manipulation comprises positioning and orientation:

1. Positioning: For the unrestricted positioning of an object within a defined space or x, y, z coordinate frame; at least 3 DOFs are necessary (also referred to as forward/back, left/right, up/down).
2. Orientation: For unrestricted orientation of an object around a so called tool center point; at least 3 DOFs are necessary (also referred to as yaw, pitch, and roll).

Positioning and orientation of objects are the main objective of any manipulator. For simple pick and place tasks, manipulators only need to have the first three or fewer DOFs (DOF 1-3) and thus a less complex robot system with less actuators, links and control system might be enough. Welding tasks in the automotive industry on a 3-D car body, however, imply that the welding tool can not only be positioned but also orientated, and thus necessitates manipulators with more than 3 DOFs. In construction, ROD is concerned with reducing the complexity of assembly tasks in order to reduce the number of DOFs needed (presented in detail in **6.2**). In Automated/Robotic On-site Factories, manipulators of the V/HDS try to cope with 3 DOFs to locate/position the components, so that simpler more robust kinematic main bodies (such as gantry type manipulators) can be used. When more DOFs are needed to orientate components, robotic end-effectors with additional DOFs are applied or the complexity is reduced by designing building and components according to ROD.

The combination of links and joints forms kinematic bodies with a geometrically definable work-space. Siciliano et al. (2010) analysed in detail examples of kinematic base bodies and identified following categories:

- Cartesian Manipulator (3 prismatic joints: P-P-P)
- Gantry Manipulator (3 prismatic joints: P-P-P)
- Cylindrical Manipulator (1 revolute, 2 prismatic joints: R-P-P)
- Spherical Manipulator (2 revolute, 1 prismatic joint: R-R-P)
- SCARA Manipulator (2 revolute, 1 prismatic joint: R-R-P)
- Anthropomorphic Manipulator (3 revolute joints: R-R-R)

Those kinematic base bodies consider mainly the first three axes and thus refer mainly to positioning activity. For orientation, further DOFs and kinematic combinations can be added on top of those base bodies. All base bodies have their advantages and disadvantages. Manipulators based on Gantry, Cartesian and SCARA base bodies are advantageous in terms of rigidity and repeatability but provide less flexibility in terms of approaching an object. Cylindrical, spherical and anthropomorphic manipulators provide less rigidity but more options in terms of positioning and approaching. The design of an object to be manipulated and related (assembly) processes (for example through ROD; for further explanation, see **6.2**) can foster the utilization of a specific base body. For example, assembly or other operations can simply be performed by an activity along the vertical axis and SCARA manipulators can be used, which are well known for high-speed, repeatability and low price at the same time. In Automated/Robotic On-site Factories, gantry type manipulators can often be found (in particular, see technical analysis of Automated/Robotic On-site Factories in **5.2** and **5.3**) due to the necessity to precisely manipulate components

of extreme weights and at high speed, which cannot be accomplished, for example by currently available anthropomorphic manipulators.

Actuators: Actuators, apart from links and joints, are a basic element of automation and robotics. Concerning the allocation of the actuators, various strategies are common. The one extreme is that actuators can be allocated near or at the joint. The other extreme is that the actuators are located at the base of the robot or outside the kinematic structure, and that the actuation force is transmitted via cables, gears or racks, for example. The first strategy is advantageous in terms of repeatability, as the actuation force can be directly transmitted, but has disadvantages in terms of the weight of the robot, as links and other actuators need to be more powerful in order to be able to manipulate joints with actuators integrated. The second strategy is advantageous in terms of the weight of the kinematic structure, as the kinematic structure itself does not need to manipulate actuators attached to its joints. Currently common types of actuators are electrical servo motors, hydraulic actuators and pneumatic actuators. New types of actuators in research and development include electroactive polymers, piezzo motors, shape memory alloy, micro geared motors, elastic nanotubes, and actuated wires. In Automated/Robotic On-site Factories the vertical and HDSs, manipulators and end-effectors are, in most cases, actuated by servo motors, whereas the (robotic) CSs, due to the forces required, are actuated by hydraulic actuators (see technical analysis of Automated/Robotic On-site Factories in **5.2** and **5.3**).

Sensor and Process Measuring Technology: Automated and robotic systems are, apart from by links, joints and actuators, specified by the integration of proprioceptive (internal) sensor systems, exteroceptive (external) sensor systems for measuring, and control systems interpreting data gathered by the sensor systems and regulating feedback. Proprioceptive (internal) sensor systems measure internal states of the system, such as angle of rotation, rotational speed or internal heat. Exteroceptive sensor systems, such as vision systems, laser scanners, ultrasonic and GPS help both to generate a picture of the environment and to determine positions of robots (including end-effector and actual positions, and angles of joints and actuators) and work pieces as a basis for robot motion planning. Both categories of sensor systems can be local (attached to the robot or end-effector) or global (distributed in the environment or somewhere in the site factory) (**Bräunl, 2008**). When dexterity, precision and repeatability are required, it is usual that data of different sensor systems are fused to generate a better picture of the environment and the state of the robot system. Furthermore, dexterity, precision and repeatability require signals to be interpreted quickly or even in real time, which means that sophisticated controllers and algorithms are necessary. Both are available today, but are still costly and error prone. Furthermore, generally each sensor system added to the system enhances the computational complexity. Although the development and integration of new sensor systems is important to enhance cognition and intelligence of automated and/or robotic systems, and the on- or off-site construction factories in which they are integrated, it will be shown later (see **6.1.10** and **6.2.5**), that it is possible to reduce sensor complexity in order to generate production systems which are more efficient in terms of performance and cost.

End-effectors: The element of the robot that gets in touch with the object to be manipulated is called the end-effector. In a serial kinematic system the end effector is usually the last element of the kinematic chain. The end-effector is a tool which is carried by the kinematic system. For each end-effector, a tool center – called Tool Center Point (TCP) – is defined. Forward and inverse kinematic representations and calculations are often related to the TCP, for practical reasons. End-effectors for all assembly task steps are available in many industries that deal with physical products (to which buildings belong): logistics, positioning, alignment, fixation and quality control. In most cases end-effectors are modularly separated from the actual automation or robot systems. Robot suppliers are not necessarily the supplier of end-effectors, which are often developed or supplied by different companies or at least specialized sections or spin-offs of robot companies (for example, Kuka Systems). This specialization has created a huge variety of end-effectors for each industry. Following basic strategies for coupling end-effectors with automation or robot systems can be identified:

- Fixed or integral end-effector
- Changeable end-effector with magazine
- Rotating end-effector (e.g. turret head)
- Parallel end-effector

On the one hand, end-effectors can be unique, customized tools, built only for a specific task or object to be manipulated. On the other hand they can be tools that are standardized (or put together by standardized modules). In reality, end-effectors are often mixtures of customized and standardized elements. In Automated/Robotic On-site Factories the changing of end-effectors allows subsystems or manipulators to be adapted to a variety of subsequent work-tasks (e.g. the subsequent positioning of columns, beams and floor slabs) or even to individual components. It will be shown that end-effectors are building material, and component type, specific (see **3.2.2**) and are an important element for achieving flexibility in off-site (see **3.1**) as well as in ONM (see **4.1** as well as **5.1**, **5.2** and **5.3**) in automated/robotic construction. End-effector technology is also the subject of analysis of the manufacturing process in other industries (see **3.3**).

Work pieces can be treated by automated or robotic manipulators and their end-effectors in a serial or parallel manner. Applying the parallel method means that a work piece is able to, for example, form a stamping mold in one motion-sequence and within a few seconds. The serial process refers to a process where a sequence of motion is needed to form a work piece. An example for this method is robotic 3-D-printing. Parallel processes are robust and fast but inflexible (molds are expensive and effort is needed to change them). Serial processes are highly flexible but inefficient in terms of time needed to form the work piece. Serial and parallel processes also require different end-effectors. End-effectors for parallel processes have to be robust and of high strength. End-effectors for serial processes are often fine-grained and relatively error prone tools. Concerning automation and robotics in construction, both serial and parallel processes are applied. In off-site production, parallel processes dominate, whereas on-site (e.g. automated construction sites) processes are rather routine. In an OEM-like integration, structure (with, for example, Automated/Robotic

On-site Factories integrating components produced off-site; discussed in detail in **6.1**) both the potential of the parallel method (such as productivity, speed, etc.) and of serial processes (such as flexibility) can be exploited.

3 Off-site Technologies Necessary for an OEM-like Industry Structure in Construction and Manufacturing of Complex Products in Other Industries

In this chapter, concepts, technologies and developments in the field of Building Component Manufacturing (BCM) based on concrete, brickwork, wood, and steel as building materials and Large-scale Prefabrication (LSP) holding the potential to deliver the complex components required by Automated/Robotic On-site Factories are introduced and discussed. Additionally, concepts and technologies of manufacturing systems of other industries are analyzed concerning their relevance for the implementation of Automated/Robotic On-site Factories. The author of this thesis has conducted several research projects (including long-term and short-term research visits to Japan and Korea) and has released several publications prior to this thesis in this field (**Linner & Bock, 2009; Linner et al., 2010, Linner et al., 2011-a; Linner & Bock, 2012**). The author does not consider an evident knowledge gap in this field and therefore only shortly outlines the concepts, technologies and developments in this chapter. However, these three fields can be considered as relevant for the deployment of Automated/Robotic On-site Factories as only advanced components provided by a strong BCM and LSP industry can reduce on-site complexity and thus build the supply backbone in an OEM-like industry structure which can be considered as a prerequisite for the successful implementation of Automated/Robotic On-site Factories.

Tunneling, shipbuilding and aircraft manufacturing have significant similarities in terms of product structure, manufacturing strategy and manufacturing systems to the approach of automated robotic component integration on the construction site. Those manufacturing systems deliver complex products consisting of more than 10,000 parts, and are – similar to the construction industry - required to produce more or less individual solutions of those complex products with mass-production-like efficiency at a reasonable cost and within reasonable and predictable time frames. The analyzed systems show that the systematization and automation of the manufacturing process of large sized complex products requires not only a high ratio of prefabrication of components, but also outstanding solutions for the final assembly as fixed-site manufacturing (e.g. “building ships”, A380 fixed-site assembly) and on-site factories (for example TBMs).

In the following, the author’s findings in the fields of BCM (manufacturing of low and medium level components; see **3.1**), LSP (medium and high-level BCM; see **3.2**) and manufacturing of complex products in other industries (focus on fixed site and on-site final assembly; see **3.3**), having relevance to the approach of deploying Automated/Robotic On-site Factories, are summarized. The chapter is concluded by the finding that the manufacturing of complex products can be systemized best by the combination of an OEM structure with a fixed-site factory approach (see **3.4**).

3.1 Building Component Manufacturing (BCM)

BCM refers to the transformation of parts and low-level components into higher level components by highly mechanized, automated or robot supported industrial settings. Definitions of components are interpreted differently by different industries and even by individual companies (see also 2.2). However, definitions of components share a common element – that they are a more or less complex combination of individual pre-existing parts and or lower level components. Pure BCM can be, on the one hand, distinguished from the transformation of raw material into parts (e.g. production of bricks or simple concrete blocks). On the other hand, component manufacturing can be distinguished from the manufacturing of highly complex modules or units (e.g. prefabrication of a finished cockpit unit or wing unit by a supplying factory in A320 manufacturing, prefabrication of highly complex modules as in the case of suppliers to the *Smart* automotive factory in Hambach). In this thesis, BCM is clearly distinguished from the manufacturing of high-level building blocks, such as building modules (e.g. prefabricated bath modules or assistance modules which can also be referred to as building subsystems) and building units (such as the LSP of fully finished three-dimensional building sections, e.g. Sekisui Heim, Toyota Home, Pana Home, Misawa Hybrid).

For highly automated units, LSP, according to the OEM model (see 2.3), component manufacturers represent Tier-1 or Tier-2 suppliers. Tier-1 suppliers would deliver components directly to companies such as Sekisui Heim, whereas Tier 2 suppliers would supply, for example, the suppliers of bath or assistance units. For current automated integrated construction sites, component manufacturers again represent Tier-1 or Tier-2 suppliers, where Tier-1 suppliers deliver components directly to the site, whereas Tier-2 would supply, for example, a supplier of bath or assistance units. In relation to the approach of real-time and building integrated manufacturing, later discussed in **chapter 6**, BCM would take the role of a tier-2 or tier-3 manufacturer, as on-site – in order to keep complexity according to ROD to a minimum – only high-level components and units are processed. As stated earlier (see 2.3), in this thesis the term “manufacturing” is used as an umbrella term which covers both production (a process or set of processes which transforms raw material into treatable parts) and assembly (a process or set of processes which joins various parts or components). BCM thus covers the transformation or preparation of individual materials and parts as well as their combination with other elements in a factory or factory like environment.

The analysis framework (*Table 3-1*) was set up to be able to identify and analyze the relationship and interplay of products, manufacturing strategy and manufacturing technology. The previously identified and discussed relevant topics in the areas modularity (see 2.2), technology and organization in manufacturing (see 2.3) and automation and robot technology (see 2.4) created the basis for the analysis in this chapter. Furthermore, the possibility to support automated and robotic processes by ROD and the possibility to generate customized (or better industrially customized) products by industrialized and highly automated manufacturing systems is analyzed. The analyzed manufacturing

strategies are additionally related to the greater context of the construction industry (current situation, market shares, and history) as well as emerging topics and innovations.

Table 3-1: Analysis framework BCM (concrete, brickwork, steel, wood).

Field of analysis	Analysed parameters
Current situation and market shares	Industry shares Manufacturing volumes Raw material consumption
History	Timeline Beginning of industrialized manufacturing Key persons and periods
Range of products	Classification based on geometry Classification based on complexity Classification based on function
Manufacturing methods	Workshop and group-like manufacturing methods Flow-line like, chain like and production line based manufacturing General strategies
Factory layouts	Comparison of various organisational settings and layouts Modularity
Subsystems, End-effectors	Subsystems (e.g. assembly lines, logistics systems, crane systems, handling devices, warehouse systems) Subsystems (e.g. welding, bolting, material gripping, material distribution, material orientation, measuring)
Emerging topics in the field	Innovations in the field due to new manufacturing methods, technologies and materials
Possibility to industrially customize	Possibility to customize product by modular approaches Possibility to customize products by automation and robot technology
End-of-life strategies	Reverse-logistics Re-manufacturing Recycling

The off-site BCM of low and medium level components with concrete and brickwork as the basic building material is discussed in detail also by Bock & Linner (2010a & 2010b). The OFM of medium and high-level components, building modules/subsystems and three-dimensional building units that use predominately wood and steel as basic building materials are discussed in the following section on LSP (see 3.2). In general it can be said that wood OFM and steel off-site manufacturing allows the OFM of components with higher added value (and thus higher level components) than brickwork and concrete OFM. As the large-scale OFM of building blocks based on steel frames (e.g. Sekisui House) or three-dimensional steel units shows, steel structures allow the generation of a carrier element or carrier frame, which can subsequently be equipped in a structured and production-line-like environment with other parts and components. Furthermore, steel is a material which can easily be processed (due to its weight and compactness, for example) with high precision in an off-site environment. The use of automated systems, robots and end-effectors for the processing of steel in SEs has been almost perfected in a large number of industries, making a huge set of strategies, processes and technologies available (see chapter 2). The restructuring of the construction industry according to an OEM-Model with on-site factories as final integrator steel based building systems can thus be considered as advantageous.

For end-effectors within the construction industry, the scale varies, as during prefabrication rather small parts and components have to be manipulated, whereas on automated construction sites, complex and rather heavy and large components have to be manipulated. On construction sites (STCRs and Automated/Robotic On-site Factories) in particular, the modularity of gripper systems is an important topic, as the building is not moving along a chain or line and it is more common, therefore, to change the tool frequently, instead of delivering the product to another machine with a fixed tool. ROD provides methods to reduce the complexity of the gripper system by the appropriate design of processes and components to be processed (for further explanation, see 6.2.7). The following examples show that end-effectors vary with material and according to the production step. Additionally, from LSP to STCRs, and from STCRs to Automated/Robotic On-site Factories, end-effectors evidently change in scale due to the dimensions and complexity of the components being processed.

3.2 Large-scale Prefabrication (LSP)

A combination of large-scale, high degree of mechanization and automation, and new (meaning not based on traditional design strategies) manufacturing optimized product structures in the Japanese LSP industry enables the generation of buildings of a generally higher quality and higher degree of individuality than the locally and tradition oriented German LSP industry. The Japanese LSP industry demonstrates that large-scale, high degree of automation and the abandonment of tradition are – contrary to the commonly accepted thinking in the German architecture and construction industry – the drivers and enablers of high value, high quality and individuality. Additionally, employment structure and salary levels in such an industry meet the requirements of a high-wage and leading industrial nation. However, a disadvantage of the LSP industry (even in Japan) is that on-site assembly processes are still human labor based, which still represent about 50% of the necessary work for companies, such as Sekisui House and Daiwa House. They are also not fully structured and the systematization and automation approaches applied in the off-site factory environment are not consequently applied on-site as well.

One particular characteristic of the Japanese LSP industry that ought to be emphasized is its OEM-like integration of parts, components and modules in the off-site factory environment. Although, German LSP companies such as Weber Haus and Baufrizt achieve a high degree of automation and excellent control of quality in their factories, due to the missing concentration of large companies and comparably low output, they do not achieve the OEM-like integration structure on which the Japanese LSP industry today is based on. The OEM-like integration structure allows for them manufacturing of components economies of scale and is a pre-requisite for the production-line based and automated final assembly in OPF manner. In Japan, LSP companies run several factories distributed throughout Japan. Each factory predominantly produces the types of houses required in the surrounding region (for example, a factory in Hokkaido is optimized for building types demanded in the region and for buildings with additional layers of insulation).

A high concentration of factories can be identified around in the Nagoya-Osaka area. This is strategically advantageous as the area is located right in the center of Japan, and factories located in that area can supply both Honshu and the Shikoku area. Major companies such as Sekisui House, Daiwa House and Sekisui Heim operate additional factories in Kyushu and in Hokkaido. Numbers and facts showing the large scale of the Japanese LSP industry are summarized in *Table 3-2*.

The manufacturing process of Japanese prefabrication companies is characterized by the shift of major work activity to a structured and automation supportive factory work environment. In contrast to conventional off-site structured construction factory environments, this is also a basis for high resource efficiency. Remaining waste is fastidiously sorted for reuse. Most Japanese prefabrication companies operate zero-waste-factories. Furthermore, all Sekisui Heim buildings can be accepted as trade-ins for new

Sekisui Heim buildings. Sekisui Heim takes back its units, disassembles the finishing and equips them on the production line with new finishing (re-customization).

Table 3-2: Performance of Japanese LSP industry in 2011.

	Founded in	Business volume/year (in mil. Yen) In mil. Euro	Output/ year	Employees (not including e.g. on-site assembly sub- constructors)	Range of products	Price range (in 10,000 Yen/tatami unit)	Number of factories
Sekisui House	1960	(1,530,577) 15,064	48,071	15,302	Steel Wooden	55-85 50-80	5
Sekisui Heim	1947	(449,000) 4,417	(14,600) 10,200	8,820	Steel Wooden	60-85 60-80	6
Toyota Home	1975	(131,871) 1,297	(5,400) 4,142	3,402	Steel	45-80	3
Daiwa House	1942	(1,116,665) 10,987	(43,000) 41,004	13,592	Steel Wooden	55-85 55-80	10
Misawa Homes	1967	(378,500) 3,724	12,353	(8,917) 694	Steel Wooden	60-80 45-90	12 (Hybrid: 1)
Mitsui	1974	(216,838) 2,133	5,230	2,326	Wooden	50-80	7
Pana Home	1963	(250,777) 2,467	10,753	4,264	Steel	50-80	2
Tama Home	1998	(153,719) 1,512	9,216	2,784	Wooden	30-50	1

A major advantage of the products of the Japanese LSP industry is their high value due to the high degree of customization and personalization achieved, and due to the continuous build up of customer knowledge. Companies generate the design together with the customer and on the basis of scientific data gathered about the user and his living habits; the company then generates the building's layout and functions. Additionally, the marketing research divisions of Sekisui House, Daiwa House, Sekisui Heim and Toyota Home generally check the customer's acceptance of the offered products and services every six months. The results of these investigations are fed back into design development stage and

are used to continuously improve the (highly modular) products (and related manufacturing and service processes). The building manufacturers try gradually increasing the degree to which customers are involved in production and development issues.

Attracting and retaining clients is essential for the success of any customization oriented strategy. Through the customization process, the companies receive detailed information about the customer and establish a strong relationship with them. Japanese LSP companies establish and maintain the relationship by extended life cycle oriented services (handover services, quality certificates and warranties, maintenance for up to 60 years, upgrade services, renovation and rearrangement services, re-customization). A common characteristic of manufacturing systems of the LSP industry is that the building systems have been changed dramatically in relation to conventional or traditional products in order to optimize them for: automated manufacturing; the strictly controlled quality assurance in the factory; the reduction of material input and waste generated by the manufacturing process (zero-waste factories) as well as the synchronization of end-of life; recycling and remanufacturing possibilities (such as the Sekisui Heim system reuse house) within the manufacturing system. The comparison of the above analyzed manufacturing systems reveals the strong relation between product (building and component structure) and the manufacturing technology (material flow, stations, end-effectors, automation ratio, on-site assembly).

The outcome of the analysis and comparison of LSP approaches that have relevance for the development and deployment of on-site factories can be summarized as follows:

3.2.1 Influence of Product Structure on Material Flow

The analysis and comparison shows that steel systems in general, and especially three-dimensional space frames (both represent a break from conventional building structures), allow for a production line based or chain like and uninterrupted material flow (flow manufacturing) throughout the whole manufacturing process.

1. In contrast to panelized systems, three-dimensional steel space frames, in particular, concentrate the manufacturing activity on a few units flowing through the factory (e.g. for a building: about 15 units versus 40-50 panels and other parts and components) and thus simplify and focus the material flow in the factory. Additionally, the three-dimensional steel space frames act as a stiff “carrier element” (similar to the car body in automotive manufacturing, for example) functioning as a kind of component carrier, which can be equipped subsequently with parts, components and modules (e.g. plumbing units). Three-dimensional space frames provide a structural element that allow interior-wall and facade elements to be clamped and fixed.
2. Two-dimensional steel frames (Sekisui House, Daiwa House) and two-dimensional wood panels also function as a carrier element in the factory; however, as these elements do not represent semi-full rooms or parts of rooms, unlike the three-

dimensional space frames, the amount of parts and components that can be attached to them is limited. Larger equipment, appliances, furniture and modules such as plumbing units cannot be carried or taken up by them.

3. Three-dimensional wooden frames (Sekisui Heim Two-U product line), like panelized steel and wood systems, do not allow for stringent organization along one main line from beginning to the end, as the production of a wooden frame's bottom, side and top panels as well as their assembly into a three-dimensional space frame involves workshop like activity. However, once the three-dimensional wooden space frames are set up, applying the finish and equipping them with technical installations, appliances and furniture can be done JIT and JIS on the production line as in the final assembly of units based on steel. In Sekisui Heim's new factory in Sapporo, three-dimensional wood and steel frames therefore already share one final assembly conveyor belt, where final assembly takes place.

3.2.2 Influence of Product Structure on Stations, End-effectors and the Factory internal Automation Ratio

The use of steel as the structural basis for prefabricated buildings (panels, three-dimensional space frames) in the factory prefabrication phase has a positive influence:

- on the use of automated systems and robot technology
- the application of JIT and JIS throughout the whole OFM process

The use of automated systems and robot technology is simplified by steel as a multitude of systems for automated positioning, adjusting and fixation of steel elements are available and proven technologies (e.g. various welding technologies). Sekisui House for example uses robots to assemble, adjust and weld the bare steel frames. Sekisui Heim uses a 3-dimensional system (similar to the automatic car body assembly line, also called Flexible Body Line, FBL, in use at Toyota Motors) to automatically position, adjust and spot weld the bottom, top and side elements of the steel units (see *Figure 3-2*, row one). Due to the stiffness and compactness of the steel (compared. to wood) steel reduced the amount of parts to be assembled, enhances accuracy and speed which then influences in series connecting and clocking of steps or processes.

3.2.3 Influence of Product Structure on on-site Assembly and the overall Degree of Automation

Three-dimensional fully equipped units simplify the amount of on-site work as well as the time needed to complete the building and allow for high quality standards, as most of the work can be conducted in the factory and thus in a structured and automation supportive environment (for further details on the OFM on basis of three dimensional steel units, see *Figure 3-2*) The high degree of prefabrication (factory based work) does not negatively influence the individuality of the building, as each unit is equipped in a OPF manner, with individual finishing, installations and equipment. However, three-dimensional units have the

disadvantage of increasing cost and effort for the transport from the factory to the site. Sekisui Heim is the only company so far that is able to partly compensate for this disadvantage by its factory network (six factories distributed throughout Japan) by assigning the manufacturing of the units to the factory located nearest to the site.

3.2.4 OEM-like Integration Structure

Companies as Sekisui Heim, Sekisui House, Toyota Home and Misawa Homes (Hybrid) in particular, which have altered the building structure as well as the manufacturing process dramatically compared to conventional construction, are embedded into an OEM-like structure where sub-factories or suppliers deliver parts, components and modules that are themselves preassembled or prefabricated. Toto and Inax (both major suppliers of bath equipment) prefabricate plumbing units (especially bath cells). The use of prefabricated plumbing units in the form of completely equipped three-dimensional cells is widespread in Japan. Prefabricated plumbing units can be considered as subsystems of buildings and are referred to in this thesis as modules.

The industrial manufacturing of bathroom and kitchen modules began in approximately 1920 in the Scandinavian countries (Sweden, Finland, Norway). Long winters and short summers, and thus also short periods in which final on-site construction was possible, necessitated the use of prefabricated elements. In Germany the industrial production of high installed, three-dimensional subsystems became popular in the early 1960s. The creation of plumbed rooms on construction sites is still often a bottleneck, because up to ten trades must be coordinated at the same times in an often limited space and to do precision work. Pre-fabrication of plumbing units, however, can take place, without friction losses and disturbance of the actual construction process, off-site and in parallel. Prefabricated subsystems, were, in the beginning used especially in the construction of hotels, hospitals, and nursing homes and especially in Japan for construction of high-rise buildings.

Today the use of prefabricated subsystems (high-level components, in this thesis also referred to as modules) is no longer limited to a specific construction type and high-end prefabricated plumbing units (Hitachi, Toto, Inax, Deba) can hardly be distinguished from a conventionally built bath. Prefabricated units of the company Deba for example are also used in large passenger ships. The three-dimensional prefabricated plumbing modules can be delivered as compact modular unit or modularized as panel system. In Japan plumbing units are already prefabricated on a production line where the modules are customized by finishing, bath equipment and appliances to individual needs (*Figure 3-1*). Bottom plates, which become part of the plumbing units, function in this process as component carriers which are subsequently equipped with parts and components.

As plumbing modules are high-level components and reduce the amount of parts and work activities in downstream processes, their use in respect to an intended systematization or automation off- or on site is advantageous. In the Japanese LSP industry, the delivery of

fully equipped plumbing units is embedded in OEM-like structure with companies as Sekisui Heim or Sekisui House as OEMs and Toto Corporation or Inax Corporation as Tier-1 suppliers.



Production of waterproof plastic bottom plates



Equipping of bottom plates with technical installation

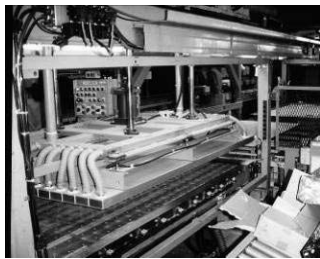

Automated production of interior finishing panels, wall panels



Assembly of (sandwich) wall panels



Completion of three-dimensional bath cell unit on a production line



Product leaving the production line: fully equipped bath cell unit (customized product)

Figure 3-1: Inax assembles customized bath modules on the production line.

Plumbing modules are demanded in conventional construction as well as by all major LSP companies, which integrate fully equipped bath cells as sub-assemblies in the factory (Sekisui Heim, Toyota Home, Misawa Homes Hybrid) or on-site (Sekisui House, Daiwa House, Misawa, Mitsui). The stringent organization along the production line in the case of Sekisui Heim in particular supports an OEM-like structure as it allows the material supply to

be entered into the final assembly and sequenced and clocked over dedicated spaces and gates along the production line. How this approach could be advanced and used to re-structure a construction industry around Automated/Robotic On-site Factories is presented and discussed in **6.1.8**, **6.1.9** and **6.2.10**.

3.2.5 Efficiency/Productivity

The analysis has shown that work productivity (output/employee) increases with the scale of the company and the number of houses built. However, the numbers do not 100% reflect the reality (due to missing inclusion of local sub-contractors in employment statistics), the work productivity of Japanese LSP companies compared to German LSP companies is enormous (output/employee per year - Sekisui House, Daiwa House: 3,2; Sekisui Heim, Toyota Home: 1.6; Kampa Haus: 1.3; Weber Haus: 0.8; Baufriz: 0.7). The figures become even more impressive considering the German LSP company with the highest productivity (Kampa Haus) produces houses of extremely low quality. The quality (and cost) of a Baufriz house is comparable to the average quality of Japanese prefabricated houses. The business volume (turnover) of Japanese LSP companies, which for each company is in the billions (Euros), clearly shows the scale of this industry. All in all, it can be said that products of the highest quality are manufactured by a minimal input of means of production - human labor and a minimal input of material. As mentioned previously in this thesis, increased productivity is an indicator of technological change. The systematization of the construction process in a structured off-site factory environment, and the use of automation and robotics in those environments is the backbone of the Japanese LSP industry. This is reflected by the given figures. Furthermore, it is remarkable that the average salary of employees of Sekisui House or Daiwa House is more than €70,000 per year after taxes (**Nikkei BP, 2009**). This is more than double the salary of, for example, an electrician in Germany. The average salary of Sekisui House and Daiwa House is on the same level as the average salary in the Japanese automotive industry (Honda, Toyota) or even slightly exceeds it (Nissan, Subaru). The fact that both companies do not include sub-contractors in their salary statistics is related to the high competition among companies to attract young and skilled engineers, who are likely to choose companies as employers who offer high salaries.



Automated profile sorting



Assisted and automated profile alignment



Assisted welding



Automated generation of 3-D space frames



Automated spot welding



Automated sending of 3-D space frame along assembly line



Assisted exterior wall assembly



Assisted placing of insulation



Step-by-step cabling on production line



Interior finishing



Assisted positioning and alignment of prefabricated bath modules



JIT and JIS delivery of parts and components to factory gates



Buffer space beside the assembly line



Preparation for shipping



Preparation for shipping



Quality control interior

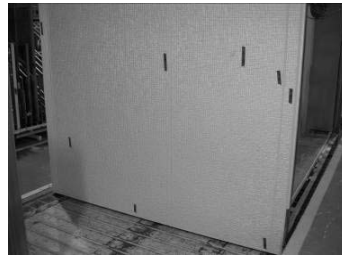

Quality control exterior



Fastidious sorting and recycling



Release of finished and packed unit



Positioning of unit on transportation truck



On-site assembly

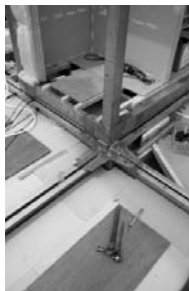

On-site assembly



On-site assembly



Finished product

Figure 3-2: Analysis of steel unit manufacturing process used by Sekisui Heim.

3.2.6 R&D and Innovation Aspects

The analysis has also shown that most German LSP companies are relatively old companies (founded 1900-1950) which have not considerably changed the structure of their products. This is in contrast to the relatively young Japanese manufacturers (see also *Table 3-2*) that have conducted a radical change from traditional wood based construction to radically new product structures such as steel panels, three-dimensional steel frames, and three-dimensional wood units. Apart from the young age of the Japanese LSP industry, the consequential modularization of products and manufacturing systems can be considered as major driver for the fast development of the Japanese LSP industry. How, on the basis of modularization, manufacturing technology and close and continuous customer relationships over time, the Japanese LSP industry is innovating further, and might eventually change from a product based industry into a service based industry, is analyzed and outlined in detail in Linner & Bock (2012).

3.2.7 Flexible Degree of Customer Integration

Japanese LSP companies allow their customers to individually choose their preferred degree of customer integration. Yet the degree of customer integration (still) determines the price. If the customer reverts to one of the basic types, chooses a standard floor plan and standard finishing for interior, windows and facade elements, the price for the house will be at a minimum. However, it is up to the customer. Japanese LSP companies are able to prefabricate on basis of their production line based and automated manufacturing systems houses with specific floor plans, special shapes, customer determined or even customer-designed individual finishing. Continual process improvements aim at gradually lowering the price impact of customization.

3.2.8 Weaknesses of the Japanese LSP Industry

A disadvantage in the Japanese LSP industry is the “exclusiveness” of the systems offered. A building built by three-dimensional steel units (by, for example, Sekisui or Toyota) has to be built up fully using those units, and the units can only come from this one manufacturer. Also, while mixing with panels or conventional construction methods (for example) is avoided by the manufacturers, this practice contradicts the advantages of different manufacturing types. Usually companies delivering buildings based on three-dimensional space frames earn money with bath and kitchen units (high amount of installation and equipment) and loose efficiency with the other rooms. On the other hand, companies that work with panels face disadvantages concerning the rooms with a high amount of equipment as those have to be integrated on-site, in a rather unstructured environment, and gain efficiency wherever simple wall panels can be combined. A combination of three-dimensional units for kitchens, bathrooms and panels for other rooms would thus unify the advantages of both systems. Currently no Japanese LSP company would be able to deliver such kits in a material uniform manner (only Misawa would be able to deliver steel units and wood panels). Another disadvantage of the LSP industry is that on-site assembly processes

are still human labor based (which, in the case of companies as Sekisui House/Daiwa House, still represents about 50% of the necessary work), are not fully structured and that the consequent systematization and automation approaches applied in the off-site factory environment are not consequently applied on-site as well. In particular in **chapter 6** it will be shown that on-site factories could integrate both off-site automation and on-site automation.

All in all, it can be concluded that the combination of large-scale, high degree of mechanization and automation, and new manufacturing optimized product structures are able to generate buildings of higher quality and higher individuality than a locally oriented and tradition oriented German LSP industry. The Japanese construction industry thus shows that large-scale, a high degree of automation and the abandoning of tradition – contrary to the commonly accepted thinking in the German architecture and construction industry – are the drivers and enablers of high value, high quality and individuality. Additionally, employment structures and salary levels in such an industry meet the requirements of a high-wage and leading industrial nation. Therefore, in **chapter 6**, an approach is discussed which aims at combining the strengths of the Japanese LSP method (in particular the unit prefabrication method) with the strength of the Automated/Robotic On-site Factory approach. The combination would be able to eliminate major weaknesses of the LSP approach (for example exclusiveness and in-ability to cover on-site processes; discussed in **3.2.8**) and the Automated/Robotic On-site Factory approach (for example lack of reduced on-site work task spectrum and work task complexity within the current generation of Automated/Robotic On-site Factories; discussed in **chapter 5**).

3.3 Complex Products in other Industries and Relevance of Fixed-Site/ONM Technology

Tunneling by TBM, shipbuilding and aircraft manufacturing, the automotive industry and automated construction sites represent the overcoming of arts and crafts based buildings by building on Tayloristic ideas, leading to mechanization, automation and finally the use of robotic systems. Furthermore, tunneling, shipbuilding and aircraft manufacturing have significant similarities in terms of product structure, manufacturing strategy and manufacturing systems to integrated automated construction sites. Also, significant similarities between LSP (e.g. Sekisui Heim & Toyota Home types, analyzed and discussed in detail in **3.2**) and the automotive industry can be identified. Tunneling, shipbuilding, aircraft manufacturing and the automotive industry deliver complex customized products consisting of more than 10,000 parts, and are required to produce more-or-less individual solutions of those complex products with mass production like efficiency to reasonable cost and within reasonable and predictable time frames. In the following sections, therefore, those industries will be analyzed according to parameters (product structure, manufacturing strategy, manufacturing system, subsystems, end-effectors, ROD, performance multiplication and productivity/efficiency) were similarly used in this thesis to analyze BCM (see **3.1**), LSP (see **3.2**) and Automated/Robotic On-site Factories (see **5.1** and **5.4.1**). It will be shown that, in particular, shipbuilding, tunneling and aircraft industry have developed methods to systemize and automate the manufacturing of customized large-sized complex products by fixed-site/ONM.

3.3.1 Tunnelling by Tunnel Boring Machines (TBMs)

Tunnels are extremely long products with a high degree of repetition of individual elements achieved by modularization. Horizontally moving TBMs (and the highly mechanized production of tunnels by them) are equal in many ways automated construction sites (and the production of a building's main structure). The mechanization of Tunneling and the introduction of Tunnel Boring Machines started in the 1980s. TBMs mechanize and automate repetitive processes as boring, segment supply and segment positioning. Leading TBM supplier are the German companies Herrenknecht and the Japanese company Mitsubishi Heavy Industries. TBMs are self-moving underground factories that more or less automatically perform excavation, removal of excavated material and supply and positioning of precast concrete segments.

Product: Besides the excavated tube itself, the tunnel consists of a reinforced concrete shell providing an F&I as e.g. traffic lane, light systems, aeration systems and traffic control system. The tunnel tubes and the concrete shell are formed by the repetition of same or similar elements and processes. Additionally, although tunnels bored by TBMs vary in diameter (5-19m), the generation of the "frame" (tube and the concrete shell) is basically the same for each tunnel. Infills, however, can be substantially different (traffic lanes, water pipes, etc.). TBMs exploit this division into frame (repetitive elements and processes) and

infill (lower degree of repetition, technical elements, etc.) by automating the production of the frame and by providing a safe workspace for the finalization of the tunnel by infill in downstream processes. Although tunnels vary in terms of diameter, boring length, soil condition and use, the F&I approach allows the very basic production principle that all TBMs follow and thus underlying engineering concepts and manufacturing technologies to be efficiently applied to a multitude of tunneling projects. Furthermore, the extreme length of tunnels supports the payoff of the on-site time and resource intensive set up of a complex and expensive manufacturing system that TBMS state.

Manufacturing Strategy: The erection of the tunnel frame as described above can be split into two major process sets:

- Prefabrication of reinforced concrete segments: they can be produced off site in a factory or - as most of that equipment today is mobile- on site.
- Boring and Segment Erection by TBM: can be operated by 15 workers in three shifts nearly continuously (2 shifts boring and segment erection, 1 shift maintenance)

The TBMs Boring and erection system is dependent on the continuous supply of concrete segments. In many cases, automated on site logistics/delivery systems are installed which transport the segments from the ground level to the erector behind the boring head. Japanese companies use ground-level, large-scale automated warehouses, which store segments delivered to the site and hand them over to the logistics system transporting them to the erector, JIS. The TBM itself provides a safe and – compared to other boring methods – healthy working environment.

Manufacturing System:

Subsystems:

- Boring Shield Mechanism
- Forward Pushing Mechanism
- System for removing excavated soil
- Betonite suspension distribution system
- Lining Segment Erector
- Bolt tightening machine/robot behind erector (Japanese companies sometimes)

End-effectors:

- Lining Segment Erector is equipped with a vacuum gripper that is able to grab and release the heavy segments. The vacuum gripper demands segments of high quality with smooth surface.
- Boring Shield is equipped with cutter disks
- Pushing Mechanisms can be equipped with end-effectors to push the TBM along on top of the segments (EPB Shield) or by pushing against the concrete shell from within the TBM (Gripper TBM).

Besides the above mentioned subsystems and end-effectors, TBMs today are equipped with sophisticated self-alignment and positioning systems that allow highly precise boring along the foreseen trajectories.

ROD: The tunnel frame is built up by the stringing together of concrete rings. Each ring is decomposed into a set of segments which can be handled and positioned by the on-site logistics system and the erector. Each ring is a chamfered cylinder.

- If the tunnel trajectory goes straight, the chamfered cylinders are twisted into an exactly opposite direction to each other.
- If the tunnel goes along a curved trajectory, the chamfered cylinders are twisted into a not exactly opposite direction to each other.

Through that alignment method each ring positioned in the tunnel is the same. The segments –although different within each ring- can thus be mass produced. If a ring consists of ten different segment parts, for example, ten different mold types can be used to produce all the segments of the tunnel. This standardization of design on ring and segment level allows for stable processes in segment prefabrication and in the TBM (line segment erection process) and states thus an example for ROD.

3.3.2 Shipbuilding

Shipbuilding had already changed from being an arts and crafts based industry, focusing on design rather than on efficient manufacturing, to a systemized and mechanized industry by the beginning of the 20th century (**Thiesen, 2006**). Drivers of this change were the shift from wood used as basic material to build ships to iron and steel as well as the upcoming demand for warships. Ships always had and still have many similarities with buildings: size, structure, materials used, providing shelter, etc. and huge ships are even organized similar to whole (floating) cities. Automated construction and deconstruction systems are often complex combinations of horizontal and vertical process, assembly and logistics sequences. The combinations of those horizontal and vertical sequences also characterize today's advanced ship manufacturing.

Product: Completed ships are mobile products, which is also referred to as large-scale modularization (**Lamb, 2003 p. 25-2**). In contrast to buildings, ships can thus be built off-site in dedicated manufacturing facilities as dry docks or “building ships”. Ships show many similarities with buildings and large cruise liners can in terms of construction, use and integrated functionalities even be compared to small cities. Large cruise liners or aircraft carriers provide shelter, food and life support for up to 7,000 people. The following similarities can be identified:

- Similar to buildings, ships and their inner structure are built up by the addition of walls, columns, beams and floor elements.

- Similar to the construction of high-rise buildings (e.g. by automated construction sites), steel as basic construction material necessitates the positioning, alignment of steel elements as well as their fixation by automated and not automated welding operations.
- Similar to buildings, ships are characterized by a F&I approach. The steel main body is filled with interior finishing. The frame has a very long life cycle (comparable to that of buildings) whereas the infill, and thus the ship, can be renewed for example, in 10-20 year cycles.

According to Lamb “the product variety and variability within shipbuilding is much closer [compared with commercial aircraft manufacturing facilities] to that of commercial building and factory construction.” (Lamb, 2003). Due to the characteristics of ships, shipbuilding shows many similarities to the construction of buildings by mechanized or automated building construction sites: “A typical shipyard must be able to deal with some significant degree of variation among ships of a type, and could very well also require the flexibility necessary to handle multiple product types.” (Lamb, 2003)

Manufacturing Strategy: Large ships are produced off-site in a ship yard. Especially during the manufacturing of larger ships (cargo ships, oil/gas tankers, cruise liners) the final assembly is done directly in a dry dock. During final assembly – due to size and weights – ships usually rest in place and assembly and logistics processes are organized around them (fixed site). According to the US Marine Board and the commission of engineering and technical systems (NRS, 1996), the following standard shipyard manufacturing process technologies can be identified:

- Material Handling
- Accuracy Control
- Steel Fabrication
- Block assembly and Erection
- Outfitting
- Testing

Outfitting is, in most cases, done in a fitting out basin in order to de-block building ships and docks. Processes and technologies are explained in detail in (Spicknall, 2003). Similar to automated construction sites, the manufacturing of ships is characterized by horizontal and vertical oriented work-process related to the manufacturing of the ships main body. In professionally organized large scale ship production four basic manufacturing strategies can be identified:

1. **Floor-by-floor assembly:** The ship is constructed layer by layer. Similar to construction process columns, beams, wall elements and floor elements are positioned, aligned and fixed by welding.
2. **Assembly by segments:** the ship is assembled in the dock by a combination of small and medium sized components and sections that have been prefabricated in other factory parts or by suppliers. Small and medium sized components and sections support the use of automated welding systems during prefabrication as

Ship Final Assembly by Building Ship

Harland and Wolff, England

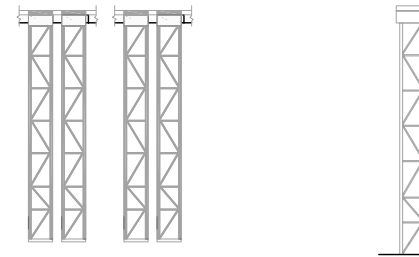
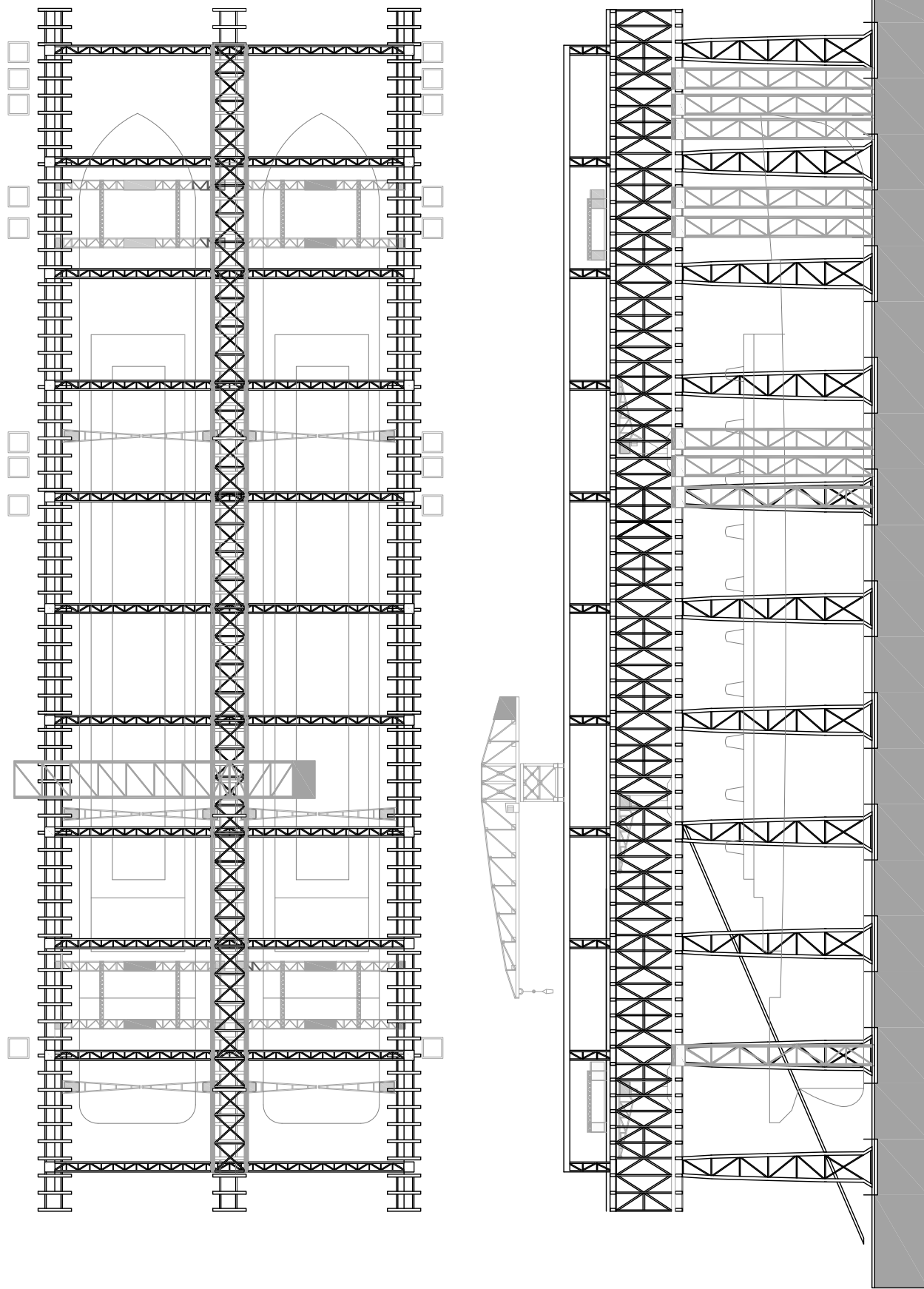

Vertical Delivery System

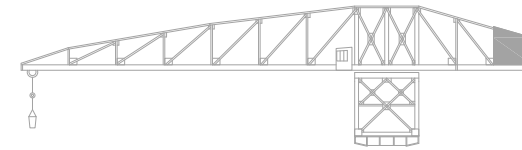

Overhead Manipulator 1

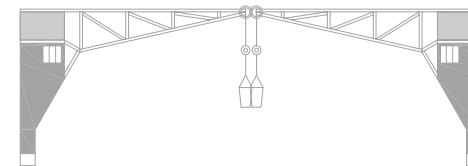

Overhead Manipulator 2

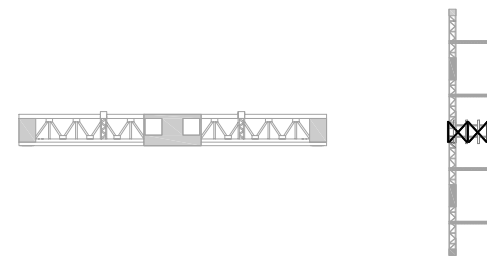

Overhead Manipulator 3

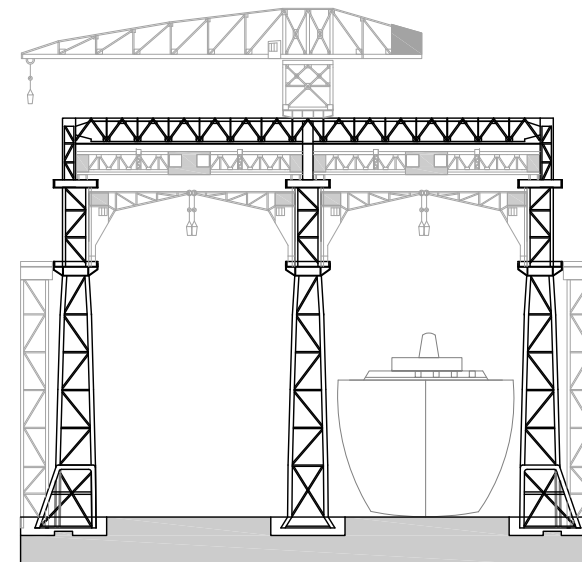

Factory Layout, Vertical Section

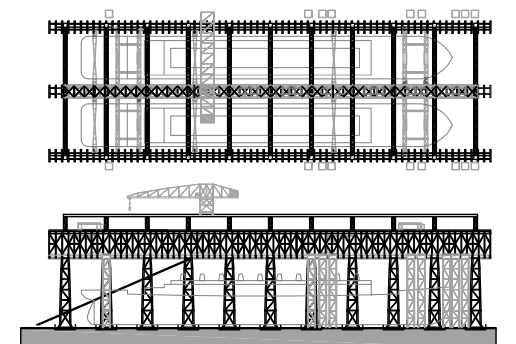

Evolution Scheme

Off-site Manufacturing of Components

Fixed-site Manufacturing (Final Assembly)

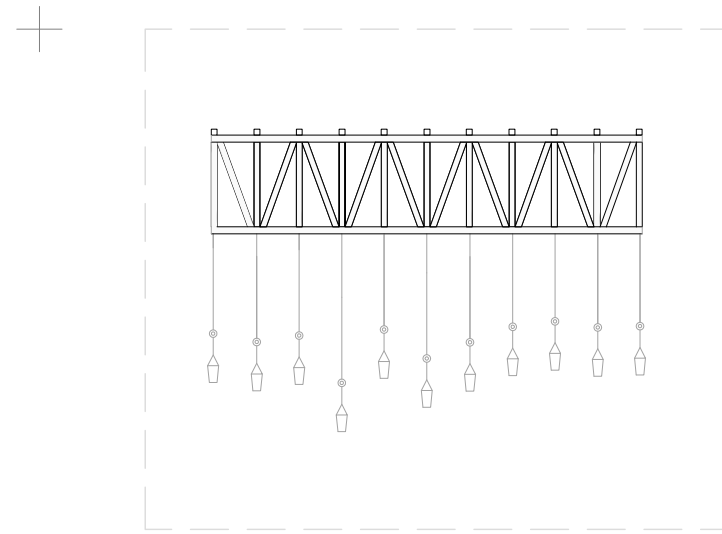
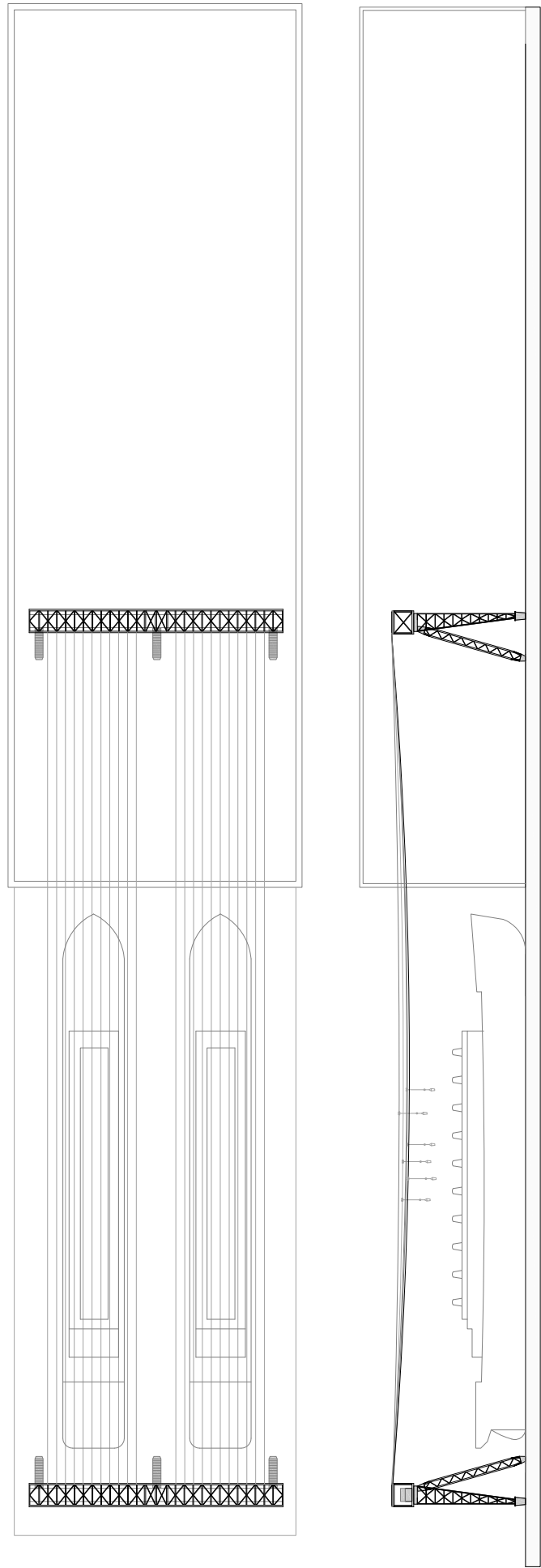

Trolley Hoist Manipulators

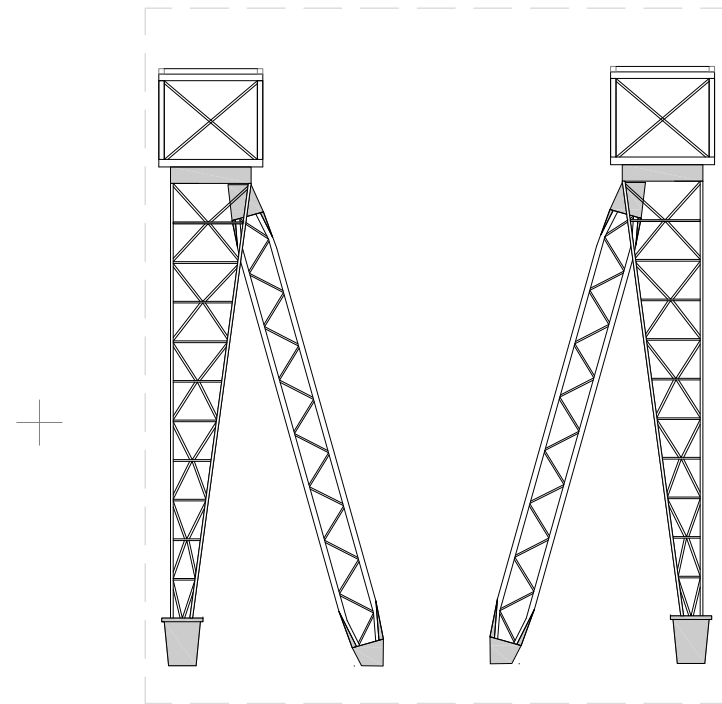

Factory Structure

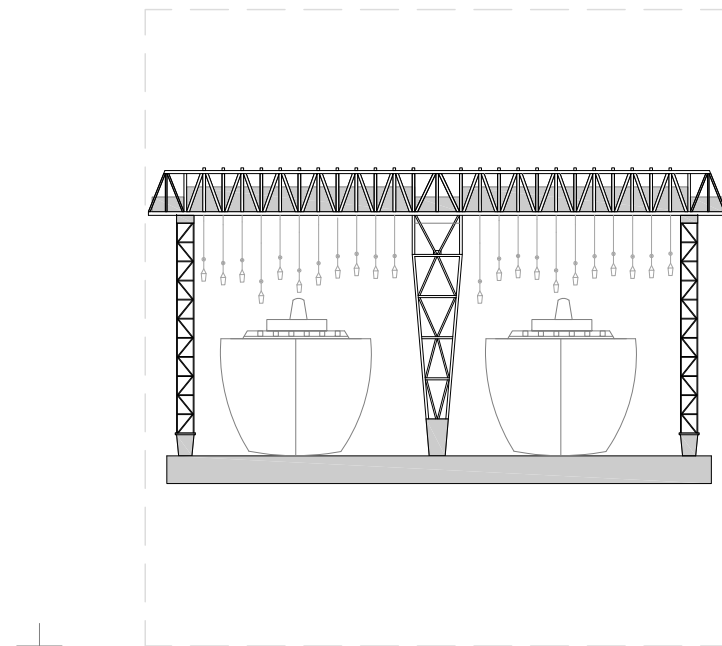

Factory Layout, Vertical Section

Ship Final Assembly by Multi-Trolley Hoist System

Warno Warft, Germany

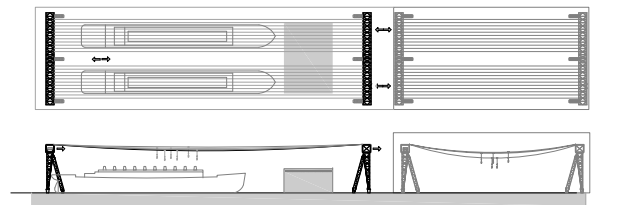

Evolution Scheme

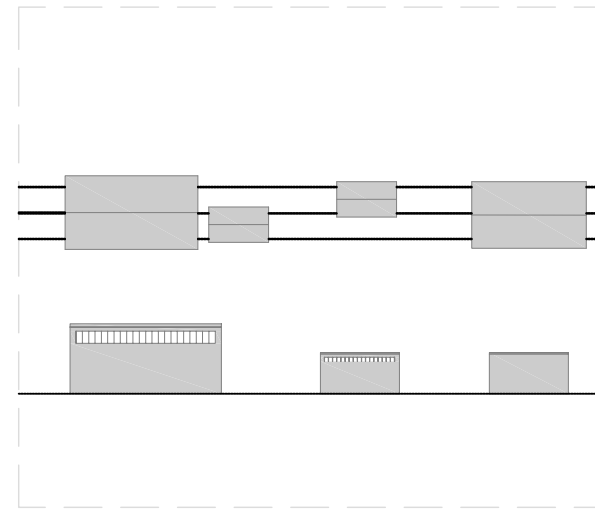
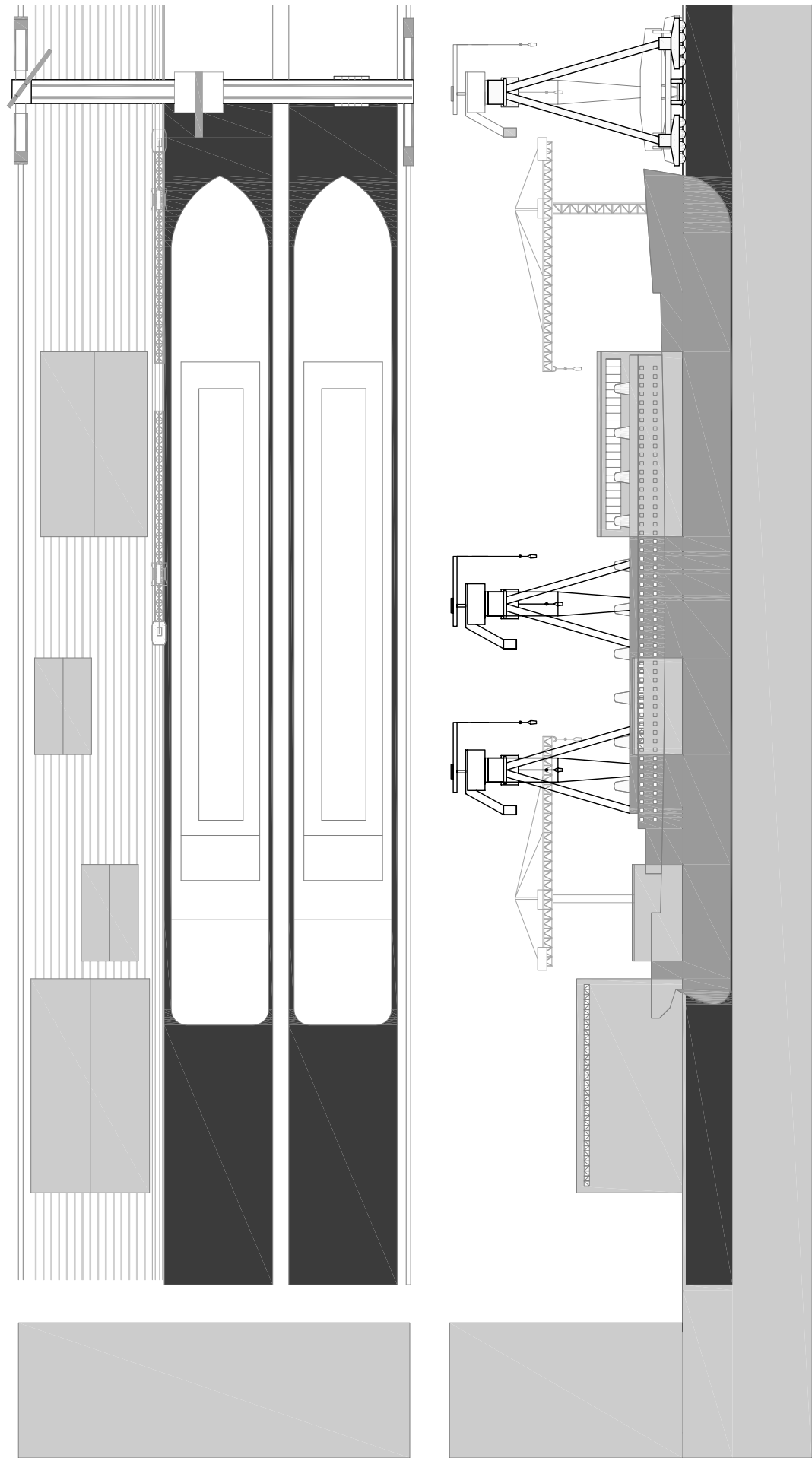

Rail Mounted Mobile Mini Factories

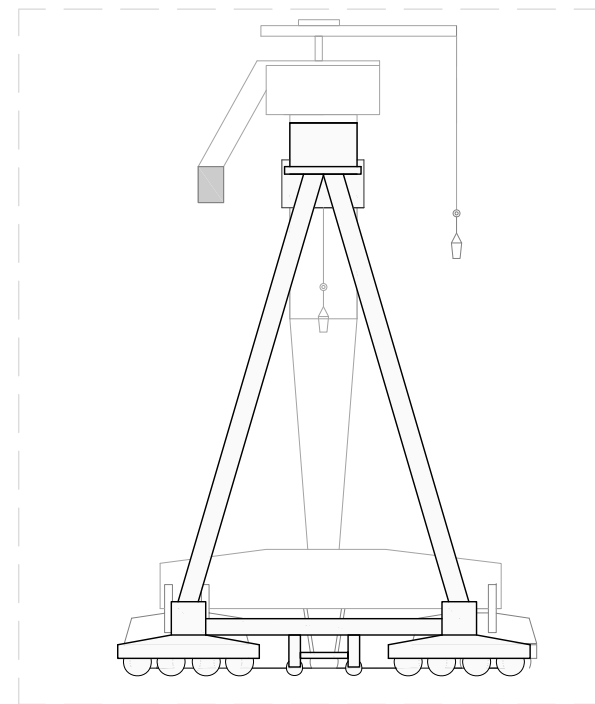

Rail Mounted Gantry Manipulator System

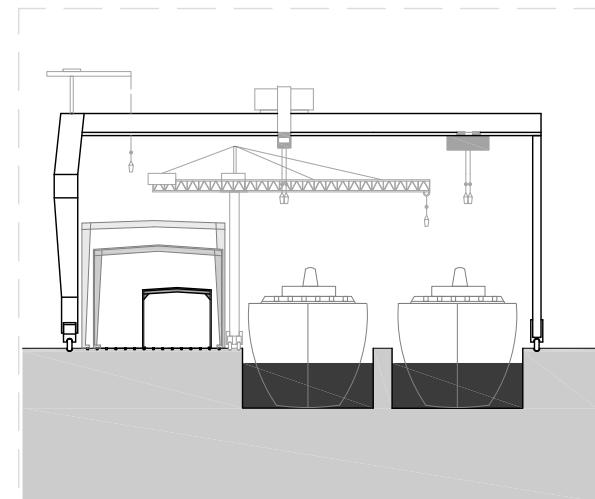

Factory Layout, Vertical Section

Ship Final Assembly in Dry Dock

Samsung Shipyards, Goje, Korea

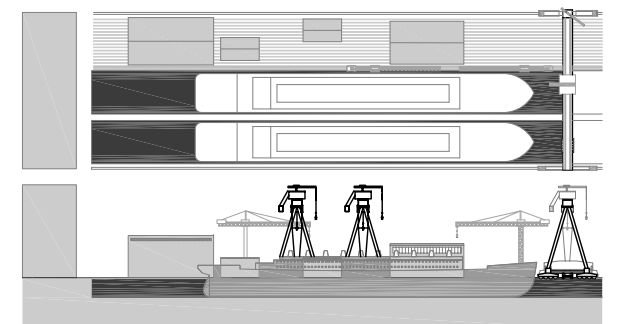

Evolution Scheme

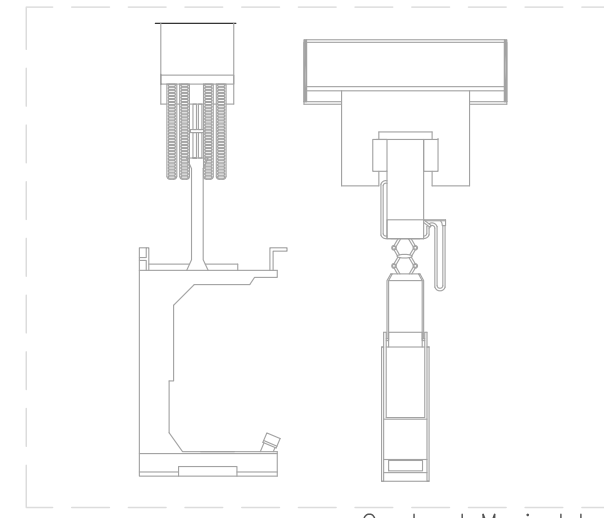
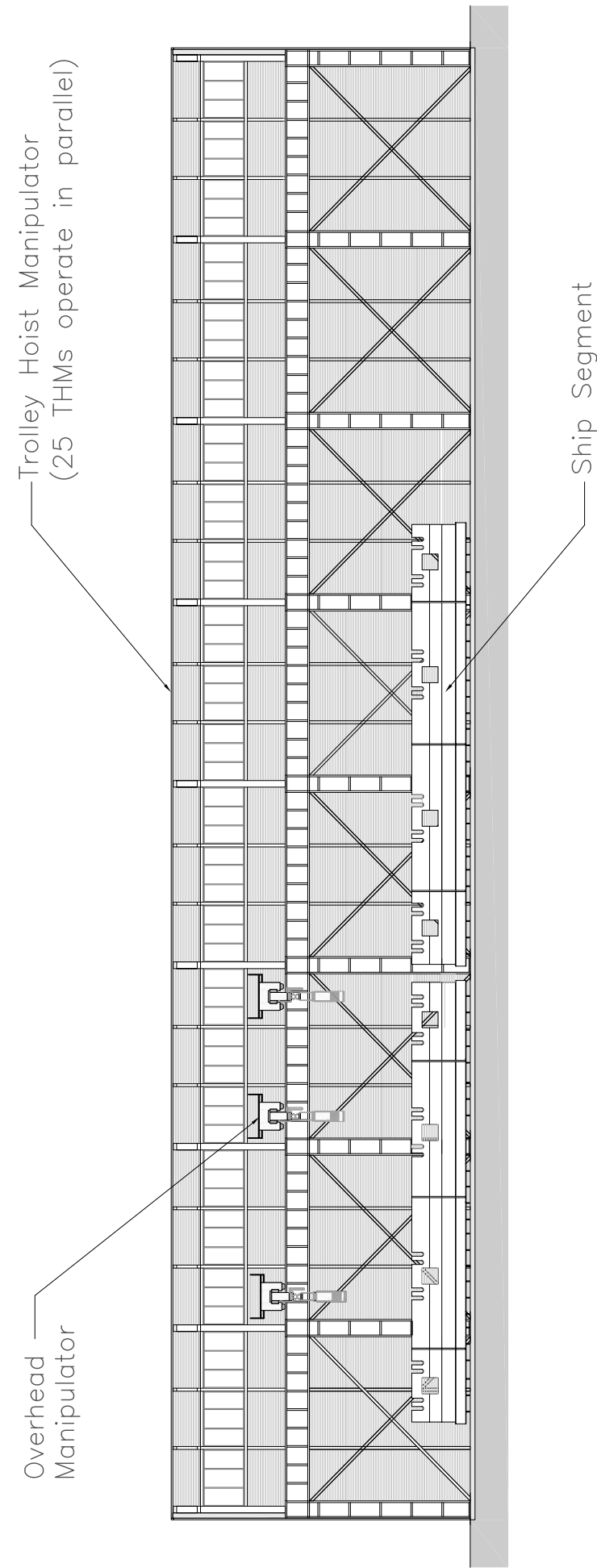

Overhead Manipulator

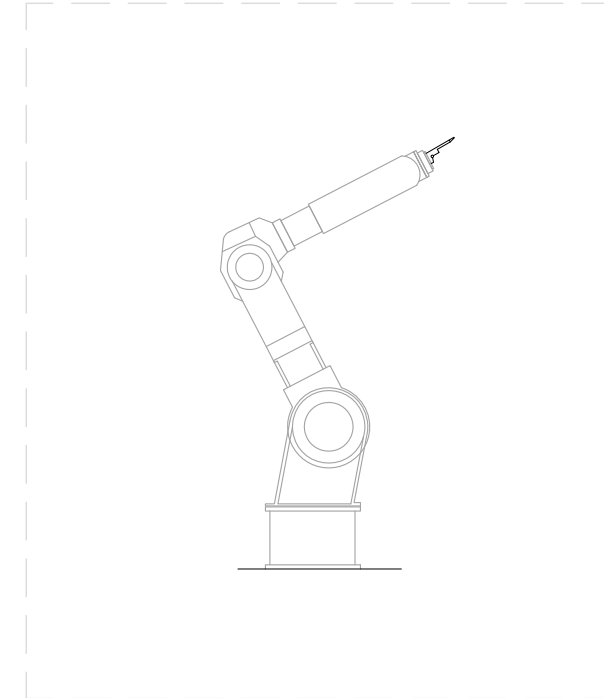

End-effector for Welding

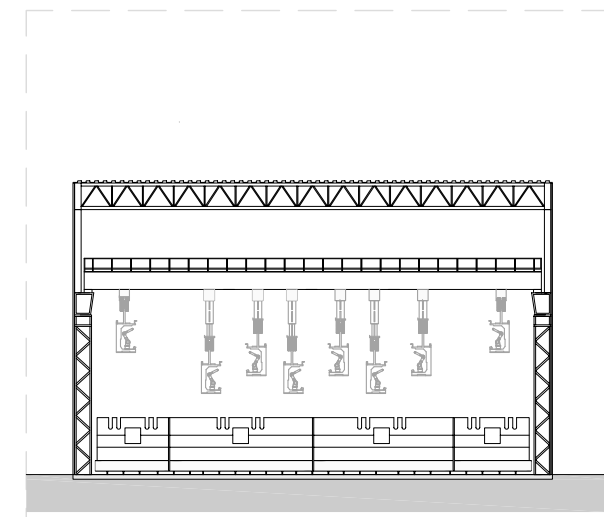

Factory Layout, Section

Automated Ship Main Body Production

Kawasaki Heavy Industries, Shipyard, Japan

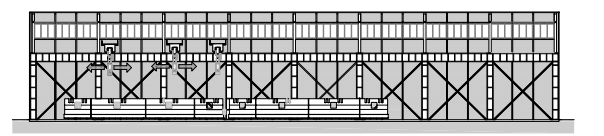

Evolution Scheme

sections can be adjusted to working spaces of, for example, gantry-type welding robots.

3. **Assembly by Mega-blocks:** Rather new manufacturing strategy. A ship is subdivided fully into sections that are fully prefabricated. The prefabrication includes the installation with technical infill (cables, pipes, etc.) as well as painting.
4. **Assembly by steel frame units:** this manufacturing strategy is mainly used in the manufacturing of cruise liners. Individual guest rooms are prefabricated on the production line (comparable to prefabrication of units by Sekisui Heim) and then fitted onto the main body of the ship.

Manufacturing System:

Subsystems:

- Weatherproof working environment
- Gantry Crane System (remote controlled/automated)
- Crane based welding systems
- Mobile welding systems
- FIL Systems (crane based, rail-guided, wheel based)
- Control Room

End-effectors:

- End-effector with single welding head
- End-effector with multiple welding heads
- End-effector with systems for handling heavy parts, components, sections or mega-blocks

Sub-systems and end-effectors are oriented mainly to the processing of heavy steel elements. Besides positioning, alignment and fixation operations the control of the flow of material in shipyards plays an important role due to the huge amounts of parts necessary to build ships. Due to advanced ERP and automation technology, individual and customized ships are built today with a high degree of automation. Logimatics's MARS System is a good reference for advanced shipyard technology. Logimatic has developed MARS, a vertical ERP solution for shipyards). MARS was derived from horizontal production streams and adjusted to the specific needs of ship production implicating vertical processes. Due to its modular architecture, the functions of the system can gradually be upgraded from modules supporting pre-calculation and budget control up to plug-ins for waste handling and life-time-services. A major advantage of the MARS ERP solution is that it can integrate existing solutions into enterprises as for example existing planning or logistics systems. Main components of shipyard ERP solutions today are:

- Planning Modules: Cost Control, Design Systems, Engineering Tool
- Logistic Modules: Purchasing, Resource Planning, Outfitting, Warehousing
- Production Modules: Steel Production, Prefabrication, Production Control
- Maintenance Modules: Maintenance, Waste-Handling, Life-Cycle Management

A special type of final assembly station in shipbuilding are the so called “building ships”. Building ships provide a dedicated space, a specialized logistics system and sometimes working platforms that allow accessibility to the product for workers. They can be used to build sections of ships or for final floor wise assembly. If larger segments or sections have to be positioned, dry docks with heavy cranes are necessary. Due to its relevance for construction automation and in particular Automated/Robotic On-site Factory development and deployment analyzed and discussed in **chapters 5, 6 and 7** following final assembly stations were analyzed in detail:

1. Harald & Wolffs Shipbuilding Yard – a type of Bauschiff or Bauhelling
2. Warno wharf – crane system with parallel processing trolleys.
3. Samsung Geoje Shipyard, Korea - final assembly of ships by Segments and Mega-blocks
4. Kawasaki Shipyard. Factory – automated production of sub-assemblies and segments

ROD: The modular decomposition of a ship has to be synchronized with the modular sourcing strategy of the shipyard. Asian ship yards (e.g. Samsung Geoje Shipyard, Korea) show a high degree of vertical integration meaning that almost all value added steps are covered starting from the processing of bare steel plates. European shipyards on the other hand rely more on the supply of components by suppliers. The design, and the modular structure of a ship in particular, have to reflect the individual strategies. Furthermore, the use of automated welding technologies necessitates that modularity allows individual elements to be produced in dedicated parts of the shipyard before finally assembly. It also requires that the interfaces between steel plates are rectangular and that between the cells, for example, enough space is left so that welding heads can operate.

3.3.3 Aircraft Manufacturing

Although aircraft are products with dimensions comparable to that of buildings, the technical engineering know-how needed is more complex, and the precision needed to produce them is necessarily higher. As with tunnels, ships and cars, most aircraft are decomposable into F&I, allowing a highly mechanized and in some parts automated manufacturing of the frame. Aircraft manufacturing shifted from a wood and handcraft based industry to a metal and production line based industry in large scale during the Second World War. Especially the huge amount of aircrafts needed for war purposes led to and high degree of standardization, modularization and systematization following the application of principles priory developed and applied in automotive industry by Henry Ford. Until the 1980s a large part of the production of lower level parts and components had been automated. Today, aircraft industry starts to automate the manufacturing of higher level components (e.g. fuselage body). An interesting production step with similarities to shipbuilding (“building ships”) and construction industry (automated construction sites) is the final assembly where major, prefabricated components are put together.

A380 fixed-site final Assembly

Airbus, Toulouse Factory

Mobile Workshop fixed-site Factory Structure

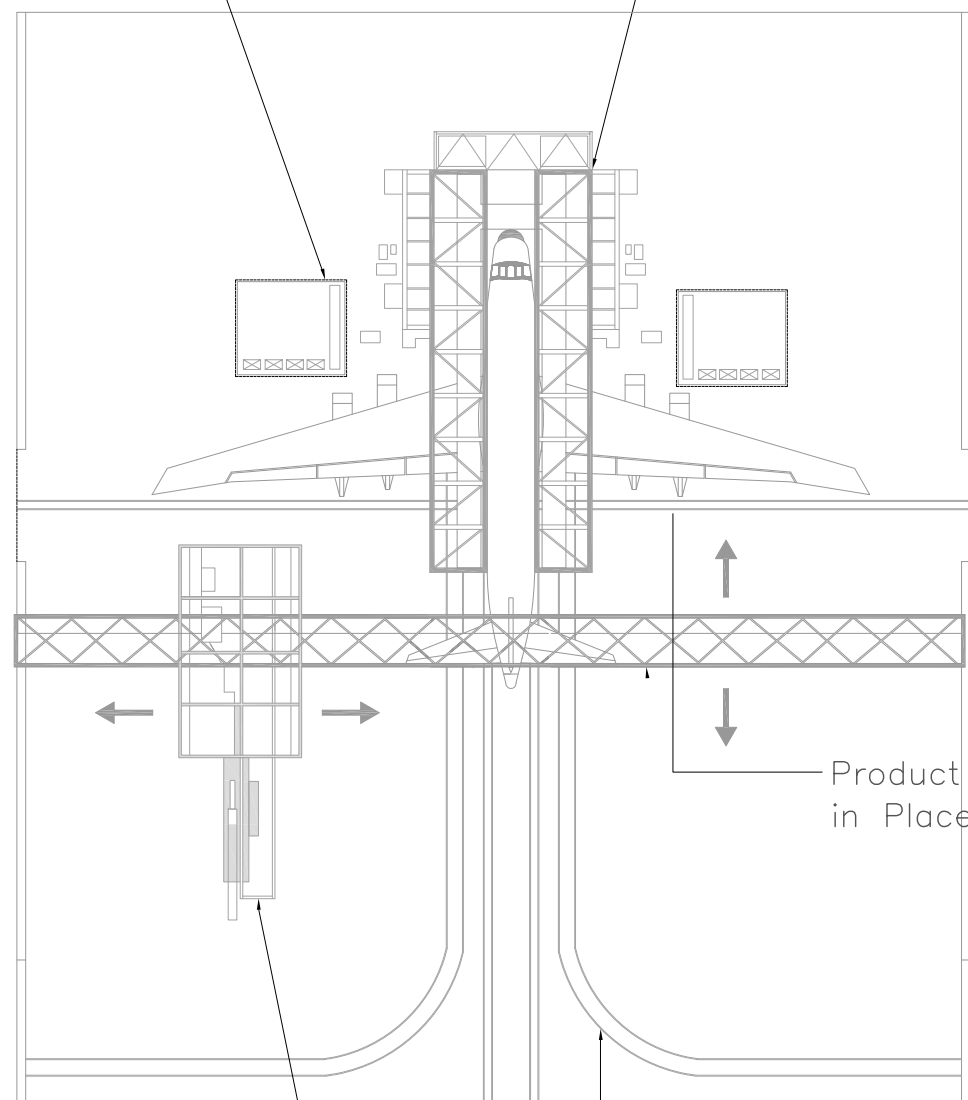

Product staying in Place (fixed-site)

Overhead Manipulator

Guiding Rails Horizontal Delivery System

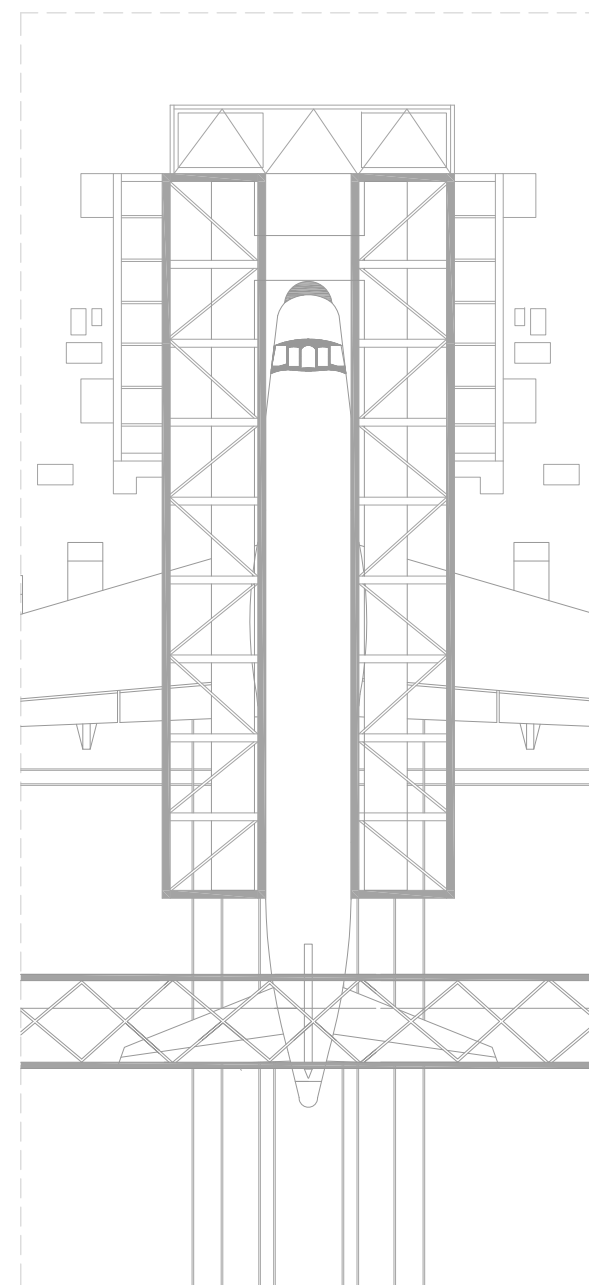

fixed-site Factory Structure

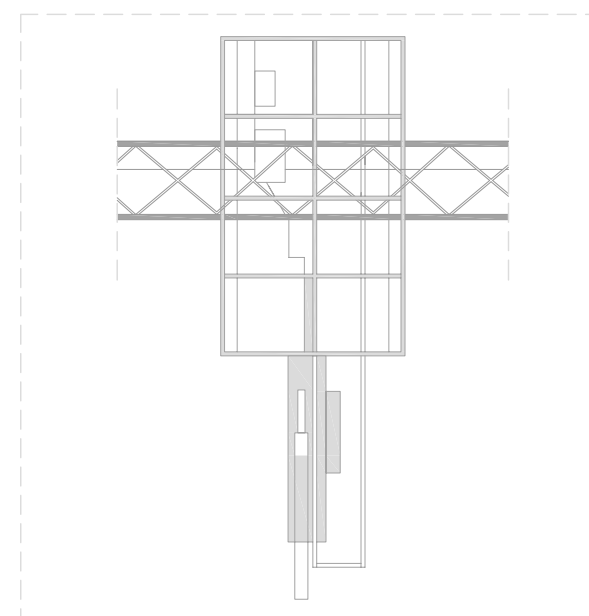

Overhead Manipulator

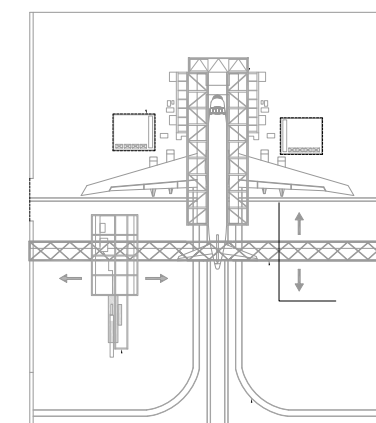

Layout Overview

Product: Passenger aircrafts are highly complex products that concentrate a huge amount of parts (more than 100,000) in a rather compact space and require the engineering and fail safe installation of sophisticated technologies for navigation, communication flying and landing. Although aircraft are products with dimensions comparable to that of buildings, the technical know-how needed in engineering is more complex and the precision needed to produce them is required to be higher. Similar to tunnels, ships and cars, most aircraft are decomposable into F&I allowing a highly mechanized and in some parts automated manufacturing of the frame (nose/cockpit-fuselage-tail unit, carbon-aluminum body + wings). Mass production like effects are generated through varying aircrafts (e.g. within A320 series) through shortening the fuselage by simply varying the amount of segments that form the fuselage and by varying the infill (interior design etc.). Although the frame provides a basis for efficient engineering and manufacturing each aircraft is different (especially in terms of infill and thus also in terms of weight which is due to fuel consumption one of the most important measurements related to aircrafts) and its manufacturing process is supervised by both engineers of the manufacturer and the customer. A standard A320 Passenger aircraft costs around 250 Million Euro. In general, the engines account for around one third of the cost of an aircraft and are supplied by third parties (e.g. Pratt & Whitney, Rolls-Royce) to the OEM (e.g. Airbus or Boeing).

Manufacturing Strategy: In the manufacturing of large passenger aircrafts two basic strategies can be distinguished.

- A320/B777 Manufacturing Type: OFM with moving product on production lane
- A380 Manufacturing Type: OFM with fixed product (fixed site)

At Airbus, for example, aircraft up to the A320 are manufactured (in terms of final assembly) in a factory hall on a production lane. The fuselage is sent along the lane and at each stage components (cockpit, wings, cabin interior, etc.) are added. A fully equipped and functioning aircraft leaves the lane for the first test flight. Larger aircraft, such as the Airbus A380, for example, or Boeing's 787 Dreamliner, are manufactured by a fixed site approach. Those products are too big to be moved along a lane and thus all sections and components are put together on a fixed placed by support of fixed site equipment. Similar to so called building ships in shipbuilding this fixed site equipment covers cranes and working platforms and mobile workshops and storages organized around the product. According to (**Horne, 1986**), following standard aircraft manufacturing process technologies can be identified:

- Sheet metal working (can be automated: automated sheet metal manufacture)
- Production of fuselage components (can be automated by using welding and bolting robots)
- Production of fuselage sections (automation in that field currently starts)
- Assembly of sections to fuselage
- Final assembly (including outfitting)
- Testing
- Painting
- Assembly of engines and delivery

Manufacturing Systems: In 2011, Boeing switched the final assembly of the B777 from a fixed-site assembly type to a moving assembly type. At the starting point of the final assembly street, the fuselage is set on a huge fixture which carries it along. The fixture moves the airplane forward continuously with a speed of 3.8 cm per minute. Material as well as tools and workforce are provided along the final assembly street JIT and JIS. The fixture not only carries the aircraft but contains multi-level working platforms with integrated workshops and tools. Logistics systems providing major components (e.g. engines) are able to synchronize with the moving main fixture and move for a certain time along with the aircraft to which the components they carry should be assembled. The switch to a moving type final assembly allowed the reduction of lead time for this process from 26 down to 17 days. In contrast, the final assembly of the A380 is done in a three-dimensional fixed site factory that encloses the aircraft and allows access to the aircraft and basically unlimited parts/components positioning and orientation possibility.

Subsystems:

- Robots for nailing of segments
- Robots for welding of wing elements (e.g. Airbus)
- Positioning systems for fuselage body assembly
- Rail-guided logistics systems for supply and positioning of major components
- Overhead cranes for positioning of major components in final assembly
- Working platforms with integrated workshops and machines/tools
- Systems for measurement and adjustment of component positions

End-effectors:

- Jigs and fixtures
- End-effectors for stamping and cutting (production of lower level components/parts)
- Water jet cutting services (end-effector with abrasive jet and drilling attachment head) (DMSI)
- Vacuum suction devices
- Tables for rotating elements and sections
- End-effectors for welding
- End-effectors for painting
- Drill bit (combined with lubricant) (Norris & Wagner, 2010, p. 96)
- Drill and bolt drive end-effector (Hempstead & DeVlieg, 2001)

Subsystems and especially end-effectors show similarity to the automotive industry, where with aluminum and carbon elements consist of almost the same material (although they differ substantially from automotive industry in terms of dimensions and design).

ROD: The modular decomposition of aircrafts into major units, such as fuselage, cockpit, tail unit, wing elements and engines allows for highly complex modules to be almost completely manufactured (and even pre-outfitted, like the fuselage part that contains the cockpit) by suppliers or related factories. In the case of Airbus, for example, this allows for a kind of company internal OEM structure where components with high added value are fed into the final assembly (e.g. components and sections for the A380 final assembly in

Toulouse come from factories scattered over Europe). Although on final assembly level automation is rare this strategy allows that supplying factories on lower levels use automation and robotics systems to fabricate components. Thus most of the end-effector systems mentioned above (end-effectors for: stamping and cutting, water jet cutting, end-effectors for welding, Drill bit, drill and bolt drive end-effector) can be found in lower level component production. However, also for the final assembly process stable processes are guaranteed by the subdivision into F&I allowing that at least frames containing the main functional elements of an aircraft are similar for each aircraft within a series.

3.3.4 Automotive Manufacturing

The automotive industry pioneered the application of Tayloristic methods and systematic production-line-based and mechanized manufacturing of complex products. Before Henry Ford had introduced the Model T and a production-line-based process, the production of only one car took days or weeks. Henry Ford brought this time down to less than 8 hours and modern factories today, for example Audi's plant in Ingolstadt are able to produce more than 30,000 high tech cars per month. Audi, in 2011, produced 1,365,499 cars worldwide, with 62,806 employees, which equals to about 22 cars produced per employee per year. The labor cost ratio in the automotive industry lies between 15 to 20% depending the type of car produced (**Audi, 2011**).

Today the automotive industry is the biggest customer of the robot and automation industry. With thriving economies in China and India, the worldwide demand for new cars is still rising and as the big German, Japanese, US and French car manufacturers can only, to a limited degree, rely on outsourcing to cheap labor countries so as not to lose quality and good image, further automation can be expected. Areas such as car body manufacturing and painting are already highly automated and it can be expected that the trend to more flexible, dexterous and human-cooperative automation and robotics will create opportunities to apply this technology also in motor and final assembly lines.

Furthermore, as the aircraft industry is currently at the transition point from advanced mechanization to automation, automation technology providers such as Dürr (with its Aircraft and Technology Systems division, **Dürr Aircraft, 2012**), that to date have mainly been active in the automotive sector, are introducing new company divisions specialized in automation in the aircraft industry. Dürr has developed the first system that is able to automate parts of the fuselage production and is currently equipping the factory of a Russian firm that produces a rival product to the A320 with that technology (**Siewert, 2012**).

Table 3-3: Comparison of manufacturing systems (final assembly stage) used to build complex products consisting of more than 10,000 parts.

	Manufacturing strategy				Product			Component manipulation		
	Location	Type	Main working direction	Order oriented view	Lead time	Parts	Cost of product in million €	Payloads	Basic material	
Manufacturing of complex non-construction products	Tunneling by TBM	On-site	Moving factory (fixed product)	Horizontal	Made-to-order	> 2 years	> 1,000,000	> 1,000	- 15 T	Concrete
	Shipbuilding	Off-site	Fixed product	Horizontal-vertical	Made-to-order	3-6 months	> 100,000 (Ass. by Mega-blocks requires lower amount)	200-800	- 50 T (Assembly by Mega-blocks up to 1500 T)	Steel
	Aircraft industry	Off-site	Moving product (A320)/fixed product (A 380)	Horizontal-vertical	Made-to-order	3 months	100,000	200-300	- 15 T	Aluminum / Carbon
	Automotive industry	Off-site	Moving product	Horizontal	Made-to-stock	1 day	10,000	0.05	100-300 kg	Aluminum
Manufacturing of complex construction products	Prefabrication (Heim/Toyota type)	Off-site	Moving Product	Horizontal	Made-to-order	2 weeks	20,000-30,000	0.5	1,000 kg- 1 T	Steel
	Obayashi type	On-Site	Moving Factory	Vertical-horizontal	Made-to-order	6- 12 Months	> 200,000	50 - 800	- 15 T	Steel
	Amurad type	On-Site	Fixed Factory	Horizontal-vertical	Made-to-order	3-8 months	> 100,000	10 - 200	- 15 T	Concrete
	Neufert type	On-Site	Moving Factory	Horizontal	Made-to-order	3-8 months	> 100,000	10 - 100	- 15 T	Concrete

3.3.5 Comparative Analysis

Sub-chapter 3.3 compares advanced manufacturing systems (final assembly stage) used to build complex products consisting of more than 10,000 parts. All compared manufacturing systems share the requirement that they have to produce more or less individual solutions to those complex products with mass-production-like efficiency at a reasonable cost and within reasonable and predictable time frames. Although the parameters and figures given in *Table 3-3* are generalized, and might in reality depend on the actual product being delivered, the table provides a summary of similarities and differences between the mentioned manufacturing systems that were identified during the analysis.

Table 3-3 shows that the final assembly processes of non-building industries (Tunneling, shipbuilding and aircraft manufacturing) have significant similarities in terms of manufacturing strategy and product strategy to integrated automated construction sites (Obayashi type, Amurad type and Neufert type). Furthermore, significant similarities between LSP (Sekisui Heim & Toyota Home types) and automotive industry can be identified. Similar to TBM based Tunneling e.g. Obayshi's Automated Building Construction System (ABCS; for a detailed analysis of this system, see 5.2.1) or Neufert's *Bauschiff* (for a detailed analysis of this system, see 5.2.7) are vertically or horizontally moving ONM systems that can be operated on-site in several shifts 24 hours a day (24/7-mode). Kajima's AMURAD (for a detailed analysis of this system, see 5.2.4) represents another basic type of an Automated/Robotic On-site Factory with a fixed factory equal in terms of manufacturing strategy to off-site located manufacturing of fixed products (shipbuilding, aircraft manufacturing). Integrated automated construction sites are characterized just as shipbuilding and aircraft manufacturing by the integration of horizontally and vertically oriented working directions. Except for the automotive industry – where a shift to more customized solutions during the next decade can nevertheless be expected – all manufacturing systems mentioned in *Table 3-3* supply products on demand and made to order. Furthermore, except for the automotive industry - which overall manufacturing process steps is definitely the most automated one – all other manufacturing strategies' final assembly processes are situated somewhere between mechanization and automation.

Similar to integrated automated construction sites in tunneling, shipbuilding and the aircraft industry, the subdivision into modules allows a high degree of automation on lower levels to produce those modules. Further modularization reduces complexity for final assembly. The modular decomposition of the mentioned products into major units allows also that highly complex modules are almost completely manufactured by suppliers or related factories (modular sourcing). In the case of Airbus, for example, this allows for a kind of internal company OEM structure, where components with high added value are fed into the final assembly (for example, components and sections for the A380 final assembly in Toulouse come from factories scattered all over Europe). Final assembly level activities can thus be kept simple.

Tunneling, shipbuilding, aircraft manufacturing, the automotive industry and Automated/Robotic On-site Factories have thus in common that the depth of added value of the final assembly stage is relatively low. Similarly, as is the case with the *Smart*, and especially with aircraft manufacturing and on-site production by integrated automated construction sites, value creation and a thus complexity is shifted to upstream production stages performed by internal or external company units and/or suppliers. All in all, related to the approach of deploying Automated/Robotic On-site Factories which will be discussed later on, tunneling (by TBM), shipbuilding, aircraft manufacturing and the automotive industry show the following elements with similarities or relevance:

5. **OEM structure:** depth of added value of the final assembly stage is relatively low in order to reduce complexity in final assembly, and allow automation in upstream manufacturing processes
6. **F&I strategy:** Products can be divided into F&I. The infill is used to customize the product and thus allows stable processes (a pre-requirement for automation) for the manufacturing of the frame (which is not or only slightly changed in order to customize the product).
7. **Final assembly:** Tunneling (by TBM), shipbuilding, aircraft manufacturing and integrated automated construction sites have in common special kinds of on-site/fixed-site factories that can only be found in the large batch production of large and complex products.
8. **Manufacturing subsystems (machines/automation/robot technology):** Logistics solutions for large and complex components, overhead crane systems, adjustable fixed site working platforms, welding systems

Besides similarities, differences are also apparent. The compared manufacturing systems vary especially in terms of payloads of components and basic building materials (component manipulation). This variation also provides an explanation for the individuality (in terms of systems and end-effectors) of each of the compared manufacturing systems, despite similarities in terms of strategy as mentioned above.

3.3.6 Performance Multiplication by Mechanization, Automation and Robot Technology

The phenomenon of performance multiplication by mechanization, automation and robot technology is analyzed using case studies. The following case studies had been conducted:

- Case Study 1: Textile Industry in England – self-acting machine systems
- Case Study 2: Woodcraft in South Tyrol – pantograph technology
- Case Study 3: Machine part production in Japan - ghost factories
- Case Study 4: Agricultural sector - towards Computer Aided Farming (CAF)
- Case Study 5: Automation in tunneling
- Case Study 6: Robotization in the automotive & aircraft industry

- Case Study 7: Performance multiplication in the construction Industry industry by automation and robotics

Ghost factories, developed in Japan the 1980's, can be classified as fundamental prototypes in development to more and more complex, autonomous and self-organizing manufacturing systems. Recent approaches aiming at cognitive factories and the application of swarm robotics in manufacturing show that today's research goal is to handle even high flexibility with autonomous systems. Flexibility (inbuilt or by modular) is a key advantage that can be provided by robot technology to manufacture complex products in a highly automatic manner. With the rising capability of robot technology, the ability to mass-customize complex products on basis of automated/robotic manufacturing systems is rising.

The case studies reveal that most comparable industries today have experienced attempts or phases of mechanization or automation where advanced machine systems were used to create an PME in order to fulfill worldwide demands. If and how such progress could impact the social setting in which it is applied is an ongoing matter of many political and scientific discussions and is not discussed in this thesis. From an economic point of view, performance multiplication and related enhancement of productivity (work productivity, capital productivity and resource productivity) is clearly seen as a driver for the creation of wealth and well-being within a society. Being aware that there have been innumerable examples to date which have highlighted that the cultural advance of humans is based on performance multiplication by machines in many fields, the case studies specifically analyzed the current state of manufacturing technology in industries manufacturing complex products.

3.4 Conclusion: Systematization of final Assembly by Combination of OEM and Factory Approach

In this chapter it has been shown that the automation of construction processes up to today can be accomplished in large scale for components (BCM, **see 3.1**), modules and whole building blocks, such as three-dimensional units as manufactured on the production line by Japanese prefabrication companies (LSP, **see 3.2**). Key in that context is the shifting of a large part of the manufacturing process into a structured off-site factory environment. The structured factory environment allows that processes can be systemized, quality can be controlled precisely and that automation and robot technology can be implemented. In a structured off-site factory manufacturing strategies as discussed in **2.3** and automation and robot technology as discussed in **2.4** can be implemented as in any other manufacturing industry.

The analysis of the Japanese LSP industry, its manufacturing technology, organizational structures and product structures reveals that the shift to automated OFM can be accomplished best by a change of the original product structure as well as the shift to an OEM-like industry structure - both directed at reducing complexity of the assembly of components, modules and units on the final assembly line. Furthermore, the large scale of the industry as well as the change from low quality to high quality products also proved to be compatible with the output capacity and precision that can be achieved by structured factory environments, automation and robot technology.

However, the analysis also showed that the approach of shifting the manufacturing of components, modules and units into off-site factories has its limitations. OFM is not able to structure and automate the whole construction process. Companies such as Sekisui Heim and Toyota Home, which manufacture with their units components on the highest possible level, are able to shift, with some buildings, up to maximal 85% of the construction work to the factory. The remaining 15% of work is done manually on the construction site and takes –depending on the building – at least another 1-2 months. Other companies that manufacture components on a lower hierarchical level (e.g. Sekisui House) require even longer (2-4 months) to accomplish the remaining on-site work. Considering the fact that those high-level components themselves are manufactured in the factory in less than four weeks, it can be said, that the labor based on-site assembly process cancels out much of that gained in time, and is a bottleneck for performance increase. Similarly, of course, the manufacturing of lower level concrete, brick, wood or steel components, which is widely deployed not only in Japan, is only able to simplify on-site construction processes, but not to fully structure, control and integrate them with off-site processes in an organizational (see also **1.3**), informational (see also **1.4**) and technological (see also **1.5**) way to a closed manufacturing chain.

Other industries (**see 3.3**), in particular the shipbuilding industry (**see 3.3.2**), aircraft industry (**see 3.3.3**) and tunneling industry (**see 3.3.1**) that are similar to the construction industry, and are required to deliver highly complex, large-sized and customized products, have

already taken a step further by developing method highly structured, mechanized or automated fixed-site or on-site final assembly methods. Those industries therefore combine prefabrication on a component level (tunnel segments, aircraft segments, ship segments) with factory-like settings (for example TBMs, A380 fixed site assembly station, building ships) that allow for the organizational, informational and technological control and thus integration of final assembly. In all three industries, the already accomplished set-up of those structured final assembly stations creates today the basis for further and step-by-step automation of final assembly operations. TBMs in a next step will be equipped with robotic boring heads that accomplish tool change fully automatically, in the aircraft industry, the automation of the assembly of the body panels of fuselages is being introduced, and ship industry is automating positioning, welding, quality inspection and final painting/coating operations. On the level of component prefabrication, increasing flexibility of automation and robot technology together with F&I strategies increases the capability to vary or customize the end products. In order to simplify (and thus structure) final assembly further and in order to gain more flexibility and choice related to components the mentioned industries have adopted and currently refine OEM-like industry structures.

Furthermore, it has been shown that performance multiplication is an important driver for the implementation of machine technology. Industries that have changed from arts and crafts based product generation to machine technology based manufacturing have done so not by introducing marginal changes to productivity, working conditions and products but by multiplying their performance. In the automotive industry, through the introduction of Henry Ford's machine based production method the lead time necessary to build a car was reduced from about two weeks done to less than 8 hours. Today much more complex cars are assembled e.g. at the Micro Compact Car *Smart's* Factory in Hambach with 3.5 hours lead-time. Similarly, TBMs, which were introduced from the 1980s onwards, accomplish tunnels, which previously required up to two decades be built, within no more than two years. At the same time, the operation of a TBM (including the feeding of the TMB with prefabricated segments) is now accomplished with no more than 20 people at a time on-site, whereas previously hundreds of workers crowded the site.

In both cases the introduction of manufacturing technology led to increased factors such as lead times and work productivity, not step-by-step or marginally, but by roughly speaking tenfold. *Table 3-4* shows that the switch of major industries from traditional crafts-based to machine-based manufacturing was accompanied by a significant PME and in particular a multiplication of production speed and labor productivity.

Table 3-4: Switch of major industries from traditional crafts based to machine based manufacturing and improvement of production speed and labor productivity

	Textile Industry	Automotive Industry	Aircraft Industry	Tunneling
Time of switch	1805	1913	1930-1945	1980s
Core Technology	Jacquard Loom	Taylorism + Assembly Line	Taylorism + Assembly Line	TBMs
Production Speed	from 2 rows of woven fabric to 48 rows of woven fabric	reduction of lead time from 10 days down to 1 day (8 hours)	reduction of lead time from several month down to days	reduction of lead time from 10 years down to 1 year
	<i>24-fold improvement</i>	<i>10-fold improvement</i>	<i>10-fold improvement</i>	<i>10-fold improvement</i>
Reduction of human labour	from 2-4 weavers /loom (1 master weaver + drawboys) down to one weaver /loom	from several cars /worker /year to hundreds of cars /worker /year	from less than one aircraft /worker /year to several aircraft /worker /year	From hundreds down to 20 workers constantly on site
	<i>multiplication of productivity</i>	<i>multiplication of productivity</i>	<i>multiplication of productivity</i>	<i>multiplication of productivity</i>
Reference	Essinger, 2004	Brinkley, 2003	Yenne, 2010	Herrenknecht, 2012

In light of such improvements by manufacturing technology, the improvements so far accomplished by BCM (see 3.1) and LSP industry (see 3.2), STCRs (see 4.1) and also Automated/Robotic On-site Factories (in particular, see 5.4 and 5.5) can be considered as marginal. In **chapter 6**, therefore, an approach to real-time construction is presented which suggests more radical improvements of performance in order to justify the development and deployment of complex and costly manufacturing technology. Also, in construction, radical reduction of construction time (down to e.g. one tenth of conventional method) and improvements of labor productivity (in particular by the tenfold) have to become subject of discussion once the introduction of advanced manufacturing technology is seriously intended.

4 Development of Elementary Technology (Single-Task Construction Robots, STCRs) and Transition to Integrated Automated Sites

After the first experiments in large-scale industrialized, automated and robotized pre-fabrication of system houses were successfully conducted in Japan (see 3.2), and the first products (such as Sekisui M1) also proved successful in the market, the general contractor, Shimizu (1975, Tokyo), set up a research group for construction robots. The goal was now no longer the mere shifting of complexity into a SE as in LSP, but the development and deployment of systems which were able to be used locally on the construction site to create structures and buildings. The focus initially was set on simple systems in the form of STCRs that could execute a single, specific construction task in a repetitive manner. The fact that STCRs were task specific made them on the one hand highly flexible (they could be used along with conventional work processes and did not require the whole site to be structured and automated), but also represented a major weakness. Since in most cases they were not integrated with upstream and downstream processes, the safety measures required by, and the inferior parallel execution of work tasks by human workers in the area where they were operating, productivity gains were often counter-balanced.

Above all, the set-up of the robots on-site (equipment, programming) was time consuming and demanded new skills. The relocation of the systems on-site was in many cases complex and time consuming. Therefore, the evaluation of the first generation of developed and deployed STCRs and the identification of the above mentioned problems led step-by-step, from 1985 onwards, to the first concepts for integrated Automated/Robotic On-site Factories which integrate STCRs and other elementary technology, such as subsystems into SEs to be set up on the construction site. For that purpose, the development of construction robot technology in general and in particular the concept of structuring on-site environments by ROD;(developed by Bock from 1984 to 1989; **Bock, 1989**) were pushed forward. As the development of STCRs, however, provided the basis for, and paved the way for, the realization of integrated Automated/Robotic On-site Factories from the 1990s onwards the development will be reviewed in the chapter (see 4.1). Furthermore, as the development of STCRs parallel to, or as subsystems of, integrated automated construction sites has continued to the present day, 140 STCRs were identified, analyzed and categorized (see 4.1.1-4.1.16).

The conceptual and technological reorientation towards integrated automated construction sites was initiated by WASCOR (Waseda Construction Robot Group) which joined researchers from all major Japanese construction and equipment firms. The first in-use phase of STCRs, as well as the conceptual reorientation from 1985 onwards laid the technological and conceptual basis for the development and deployment of Automated/Robotic On-site Factories from 1989 onwards.

4.1 Single-Task Construction Robots (STCRs)

At the end of the 1970s, Shimizu and other Japanese general contractors conducting large building and infrastructure construction projects saw a huge potential in such construction robots. Finally, with the beginning of the robotics boom in the early 1980s, in which automation and robot technology in all industries in Japan suddenly spread enormously (see also 2.4), the theme became so relevant for the Japanese construction industry that eventually even the Japanese government started to promote and bring forward the subject. This was also due to the chronic shortage of skilled workers in Japan. Finally, in 1978, JARA (Japan Industrial Robot Association) under guidance of MITI (Ministry of Trade and Industry) established a commission headed by Professor Yukio Hasegawa for the analysis of applications and development of automated systems and robotic technology in construction. Participants of this commission were mostly young and motivated engineers from the major Japanese construction companies, and general contractors and machine builders. The commission quickly became a “germ cell” for new concepts, and step by step specific research projects and robot systems were set up and implemented by companies.

Numerous universities followed this trend. Waseda University, for example, founded the legendary WASCOR group (Waseda COnstruction Robot group) which started developing automated and robotic construction technology using an interdisciplinary, cross-sector approach. Then, in the early 1980s, the coordinated activities of the large, national research institutes followed. In 1983, AIJ (Architectural Institute of Japan) and its commission, responsible for building materials and construction methods, implemented a 15-headed group for automation and robotics in construction. Shortly afterwards, JSCE (Japan Society of Civil Engineers) followed, and from 1985 the renowned BRI (Building Research Institute of the Japanese Ministry of Construction) started to work with the Center for Development on systems for robotic assembly (e.g. Solid Material Assembly System, SMAS). In 1987, BCS (Building Contractors Society), whose members were once more the major construction companies, started with a systemic assessment of the need and potential of automation and robotic technology, in particular for sub-contractors, equipment manufacturers, and construction equipment rental companies.

The reasons for the synergistic activities of government, national research institutes, general contractors and academic institutions had both political and socio-economic grounds. For example, the low productivity in the construction industry compared to manufacturing industry, the skilled labor shortage, the aging of construction workers, the increasingly poor workmanship and work-related diseases, and poor working conditions were controversial topics of discussion for the public. The construction industry, which in Japan has traditionally had a high reputation in society, thus faced strong pressure to improve the working environment and the general image of the construction industry.

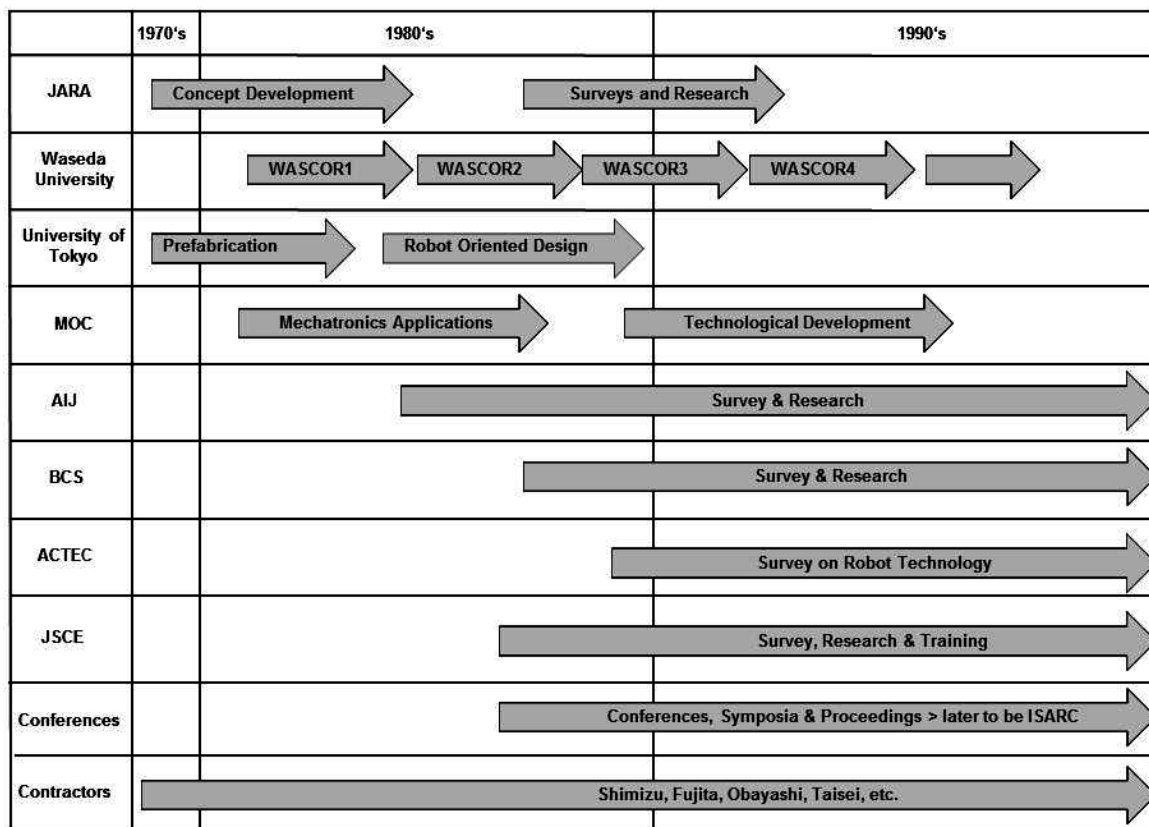

Figure 4-1: Timeline showing activity of institutions participating actively in the development of STCRs (refined and complemented with own information on basis on basis of **Cousineau & Miura, 1998** and **1998; Hasegawa, 1999**)

Figure 4-1 outlines the timeline of activity of above named institutions participating in the development of STCRs. All in all, the following institutions were involved in the development and deployment of automated and robotic technology during the 1980s and 1990s (firstly in the form of STCRs and later in the form of integrated Automated/Robotic On-site Factories) for on-site building construction:

- Japan Robot Association (JARA)
- Ministry of Industry and Trade (MITI)
- Waseda Construction Robot Group (WASCOR)
- Ministry of Construction (MOC)
- Architectural Institute of Japan (AIJ)
- Building Contractors Society (BCS)
- Advanced Construction Technology Center (ACTEC)
- Japan Society of Civil Engineers (JSCE)
- Building Research Institute of the Japanese Construction Ministry (BRI)

- Research Institutes of big construction companies (Shimizu, Obayashi, Kajima, Maeda, Goyo, Toda, Taisei, Fujita, Kumagai)
- Manufacturers of automation and robot technology
- Construction/manufacturing equipment suppliers (e.g. Komatsu, Hitachi, Mitsubishi, Kawasaki, Hazama, Mitsubishi, Ishikawajima, Kamiuchi)
- Universities: Waseda University, The University of Tokyo, Tokyo Institute of Technology

The following R&D investment sources contributed to automated and robotic technology (first in the form of STCRs and later in the form of integrated automated sites) for on-site building construction during the 1980s:

- R&D budget of construction companies
- R&D budget of equipment suppliers
- Ministry of Construction (MOC)
- Manufacturers of automation and robot technology

STCRs are systems that support workers in executing one specific construction process or task (e.g. digging, concrete leveling, concrete smoothing, and painting) or by completely taking over the physical activity of human worker necessary to perform this one process or task. In addition, the processes and tasks they support or supplement can be allocated to a specific profession or craft. Furthermore, the processes and tasks for which STCRs were developed have in common that they necessitate a high rate of repetitive sub-activities. Further common characteristics are:

1. STCRs are highly specific, not only to a profession, but even to a task within a profession (e.g. different systems for concrete pouring, leveling and smoothing, which all fall within the realm of the “floor layer” profession)
2. Enhanced productivity compared to conventional labor and machine-based execution of work tasks:
 - a. More m²/hour than conventional execution (for example, concrete floor finishing rate – labor based: 100-120 m²/hour; concrete floor finishing rate robot: 300-800 m²/hour, according to **Cousineau & Miura, 1998**)
 - b. Better labor productivity
3. Positive impact on quality through precise control of functions and operations (e.g. uniform distribution of paint) and by allowing that execution to be recorded or monitored in real time
4. Improvement of working conditions: dangerous and heavy physical work is reduced
5. Most robots allow for various operation modes: automatic sensor-guided, automatic pre-programmed, remote controlled
6. Positive impact on resource consumption through precise automatic control (e.g. painting robots ensured that the amount of paint was precisely controlled and that spare paint was collected and reused).

7. In most cases, simple but robust sensor technology: gyroscopes, simple laser measuring systems, touch/pressure sensors, etc.
8. In many (but not all cases) no more than one operator required to supervise the systems (systems supervised by two or more persons are inefficient, for further explanation, see **6.2.6**)

As in any other industry, concepts of modularity developed slowly and step by step over time. Modularity, and thus adaptability to multiple work processes or tasks, was not a characteristic of STCRs from the beginning. This reduced the operational scope of the systems and enhanced the cost of the robot systems, despite the above mentioned beneficial characteristics; as such, one was not able to distribute that cost over various work activities (as with conventional multipurpose construction equipment, for example). Some companies introduced modular approaches only in later robot generations (e.g. Komatsu/Kajima) and in integrated automated construction sites, such as by allowing for end-effector change.

The fact that STCRs were task specific, made them on the one hand highly flexible (they could be used along with conventional work processes and it was not necessary for the whole site to be structured and automated), but also presented a major weakness. As in most cases they were not integrated with upstream and downstream processes, this demanded safety measurements and hindered parallel execution of work tasks by human workers in the area where they were operated and productivity gains were often equalized. Above all, the set-up of the robots on-site (equipment, programming) was time consuming and demanded new skills. Furthermore, the relocation of the systems on-site was in many cases complex and time consuming. In **4** it is outlined how the evaluation of the first generation of developed and deployed STCRs, and the identification of the above mentioned problems, led step-by-step from 1985 onwards to the concept of Automated/Robotic On-site Factories. Although STCR technology was improved during the 1980s and the 1990s step by step and advanced from so called first generation robots to second and third generation robots (outlined in more detail in **Cousineau & Miura, 1998**), automated/robotic on-site factory approach provided better possibilities to reduce work task spectrum and human labor as well as pre-structuring the environment as basis for higher automation ratios and JITJIS like factory internal component processing.

However, new developments show that major Japanese construction companies today have returned to single-task-like approaches. Obayashi, for example, today no longer uses its integrated, automated construction site (Automated Building Construction System, ABCS) as a total system, but applies some of its subsystems as STCRs (for example automated logistics systems, welding systems; for further details, see **5.2.10**). By not directly and rigidly connecting those systems, Obayashi gains workshop like flexibility (in contrast to chain-like organizations to which integrated sites were formerly oriented), which is necessary when constructing buildings such as the Tokyo Sky Tree, which changes its shape several times from bottom to top. New management approaches, acquired knowledge about the deployment, and work process integration of single robotic or automated applications, digital work process management and control software, positively

influences the integration of such systems today and enhances their efficiency compared to the first generation systems deployed during the 1980s. The development and deployment of STCRs is thus today, in times of where more and more individuality of any product is demanded, more relevant than ever.

As part of this thesis, 140 STCRs were analyzed according to the following framework:

- Background behind development
- Operational capacity
- Technical description
- Control strategy & informational aspects
- Dimensions and workspace
- Description of robot supported construction work process and comparison with conventional work process

On basis of the analysis, 16 categories were set up. The classification follows a work-task oriented approach, as the analysis shows that STCRs do not introduce new organizational settings, but aim at supplementing existing work-tasks in conventional and at best slightly altered construction environments. The categorization thus refines and extends existing classifications (**Bock, 1989; Cousineau & Miura, 1998**) which followed a similar strategy but did not (as the development continued since then) cover the amount and variety of STCRs considered in this thesis. A focus in this chapter is on construction robots used on-site to construct buildings. Construction robots used off-site or to construct, for example, roads, bridges, tunnels, etc., are not considered in this chapter.

The analysis of STCRs was conducted on basis of a large picture and information archive provided by the primary supervisor of this thesis, technical data, technical drawings and STCR analysis methodologies introduced by Bock (**1989**) and technical data, product description brochures and background information provided by companies in charge of the development of individual systems. A further but incomplete source with detailed technical drawings stated the Construction Robot System Catalogue in Japan (**1999**) published by the Japanese Robot Association. Detailed analyses and comparisons of a limited amount of concrete finishing robots, facade painting robots, facade inspection robots and interior finishing robots by Cousineau & Miura (**1998**) completed general and technical information of the analysis of systems in those categories. Helpful for the identification of robots developed before the year 2000 was also the catalogue 'Robots and Automated Machines in Construction' published by the board of directors of International Association for Automation and Robotics in Construction (**1998**). Helpful for the identification of robots developed *after* the year 2000 were the Proceedings of the International Symposium of Automation and Robotics in Construction at which the "who's who" of specialists involved in the development of construction automation systems and robots meets on a yearly basis.

4.1.1 Earth and Foundation Work

Earth and foundation work is a basic type of work that needs to be done for any type of construction. Furthermore, earth and foundation work, in contrast to other works related to the construction of, for example, the more visible above ground sections of a building, have limited impact on a building's individuality. It is thus a work process which, seen over several projects, appears in a considerable amount, and which is at the same time a process that can comprise many repetitive sub-activities (e.g. excavation operations). As this forms a perfect basis for automation, the attempts in that field (developments and deployed systems) are numerous, ranging from leveling and earth work operations to foundation casting/laying and filling and compaction operations.

1	Overhead Rail-guided Digging Robot	Shiraishi
2	EM 320 S Robot for Digging Vertical Shafts	Shimizu
3	Automatic Digging and Soil Removing System	Tokyu
4	Overhead Rail-guided Digging Robot	Mitsui
5	Automatic On-site Soil Removing/Logistics System	Kajima
6	Robot for Accuracy Measurement and Initial Marking of Foundations and Base Floors	Obayashi

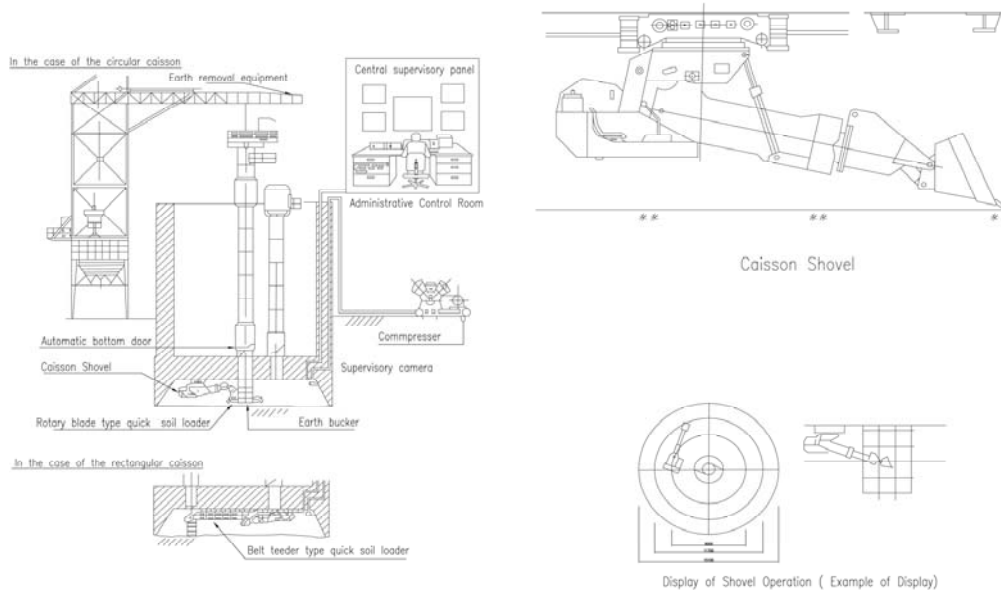

Overhead Rail-guided Digging Robot; Shiraishi (graphical representation according to **Construction Robot System Catalogue, 1999**)

4.1.2 Reinforcement & Rebar Production & Positioning

Concrete reinforcement operations involve cutting and bending of rebars, the precise (relative to each other) arrangement of those rebars, binding of rebars and the final positioning of the rebar element or mesh on a floor, or in a mold or formwork system. Back accidents and damage to the musculoskeletal system are about ten times more likely during reinforcement work than, for example, during painting work (**Wickström, 1985**). Furthermore, ergonomically critical postures, lifting and carrying operations represent a severe health threat in the long-term. For health insurance companies, the conventional labor-based operations related to reinforcement and rebar production and positioning is thus considered as work involving both a high short and long-term risk. Automated systems mitigate risks and the impact on health of workers and enhance the quality of the reinforcement in particular in large construction projects as power plants and high rise buildings.

7	Robot for on-site production (alignment and binding) of 3-D reinforcement bar meshes	Taisei
8	Robot for On-site shaping of reinforcement bars	Taisei
9	Robot for Positioning of Heavy Rebars	Kajima
10	Automated Crane for Rebar Positioning	Takenaka
11	Robot for Positioning of Heavy Rebars	Kajima,

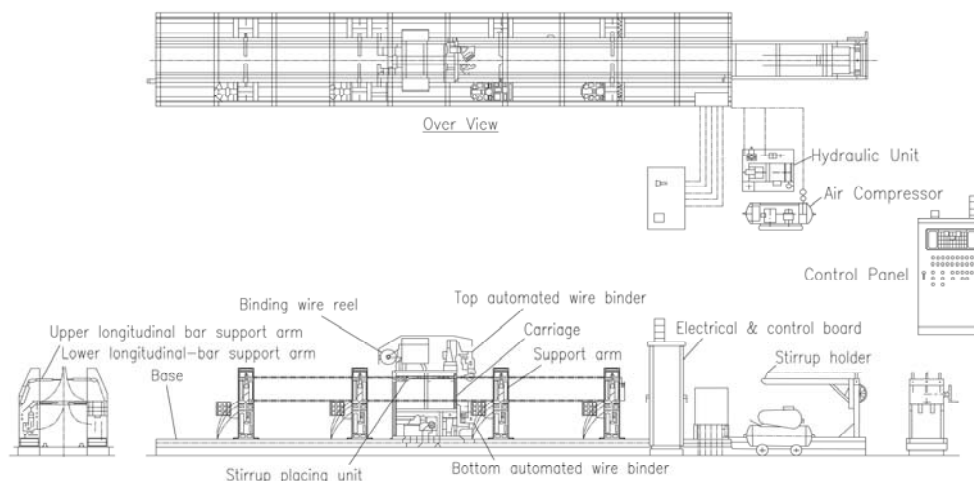

Robot for On-site production (alignment and binding) of 3-D reinforcement bar meshes; Taisei (graphical representation according to **Construction Robot System Catalogue, 1999**)

4.1.3 Concrete Distribution

Concrete distribution systems are used to distribute mixed concrete with uniform quality over large surfaces or over formwork systems. Concrete distribution involves the continuous supply of concrete (pumps, hoses), a system which slides in a certain pattern over the area where the concrete has to be distributed and utilizes a concrete ejection system. Systems can be operated manually, tele-operated and sometimes sensor guided and fully automatic. In relation to the surface where the concrete has to be distributed, concrete distribution systems can be truck mounted, stationary or mobile.

12	DB Robo Concrete Distributor	JIR (Japanese Research Institute),
13	Mobile Concrete Distribution Robot	Tokyu
14	Concrete Distribution Robot	Takenaka
15	Stationary Concrete Distribution Robot	Obayashi & Mistubishi
16	Automatic On-site Concrete Logistics System	Konoike,
17	Concrete Distribution Robot	Kajima
18	Concrete-floor Precision Measuring System	Kajima

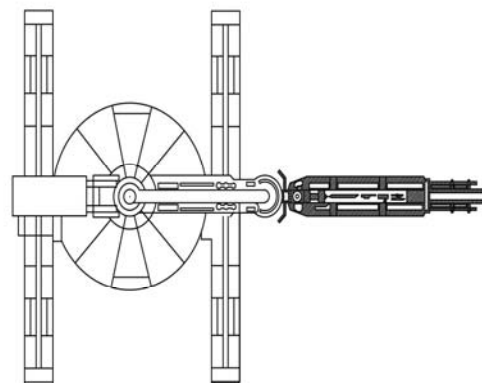
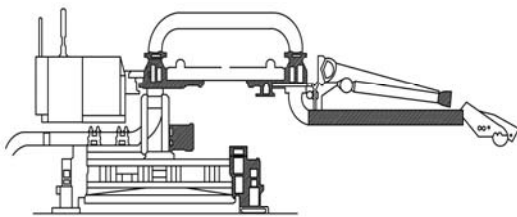

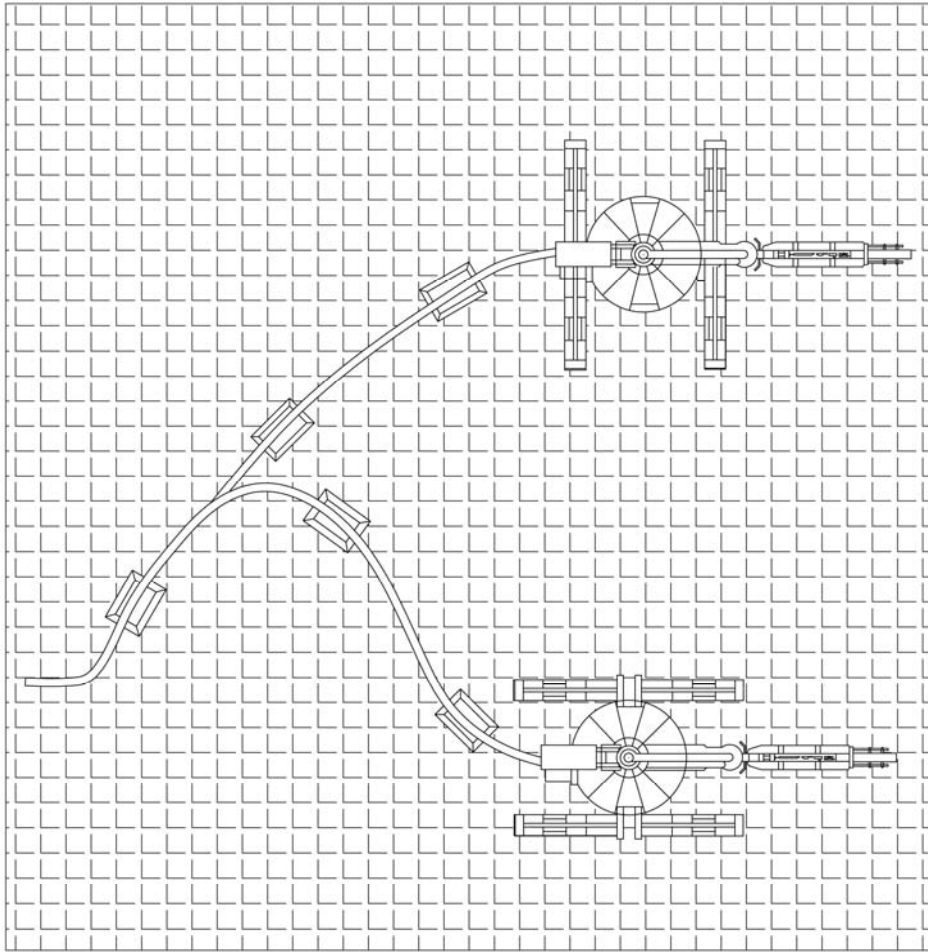

DB Robo Concrete Distributor, JIR

4.1.4 Concrete Compaction

Concrete compaction extracts air from the concrete, compacts the particles inside the concrete mix and thus enhances its density, strengthens the interconnection between the concrete and reinforcement, prevents the common phenomenon of concrete shrinkage to a certain extent and in many cases generates a better surface quality. Just as during the 1980s, today a considerable amount of concrete structures are cast On-site; automated or robotic systems are able to ensure uniform compaction (and thus concrete quality). Furthermore, if properly integrated with other operations, concrete compactions are able to enhance the concrete pouring rate.

19	Concrete-wall Compaction System	Obayashi
20	Concrete-floor Compaction System	Takenaka;

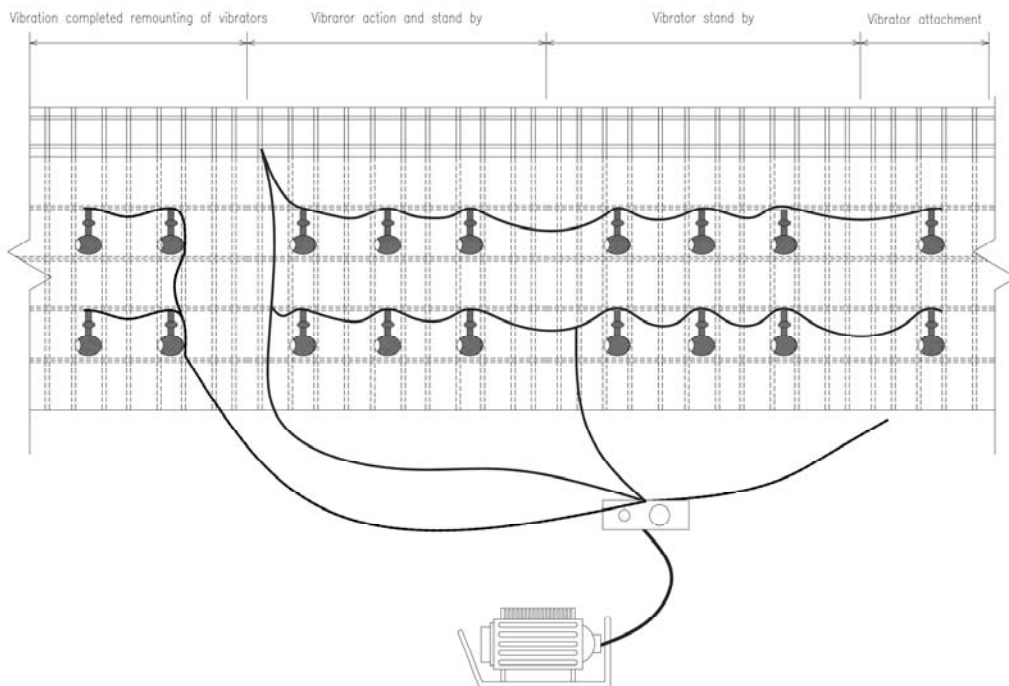

Concrete-wall Compaction System; Company: Obayashi

4.1.5 Concrete Levelling

Concrete leveling is the process of leveling the poured or roughly distributed concrete in order to have a more compacted and planar (but not finished) concrete layer. It involves a high amount of repetitive operations (e.g. skimming with slide dampers). If manually done continuous input of strong physical power is necessary, which limits the operational speed, making conventional labor based concrete leveling a time and resource intensive construction operation. Automation of leveling operations – similar to concrete finishing operations - speeds up the leveling process, enhances labor productivity and maintains a highly unique surface quality for the whole surface.

21	Automatic Floor Screeding Robot	Company: Takenaka
22	Floor Leveling Robot CALM	Company: Fujita
23	Automatic Compacting and Leveling System	Company: Mai International,

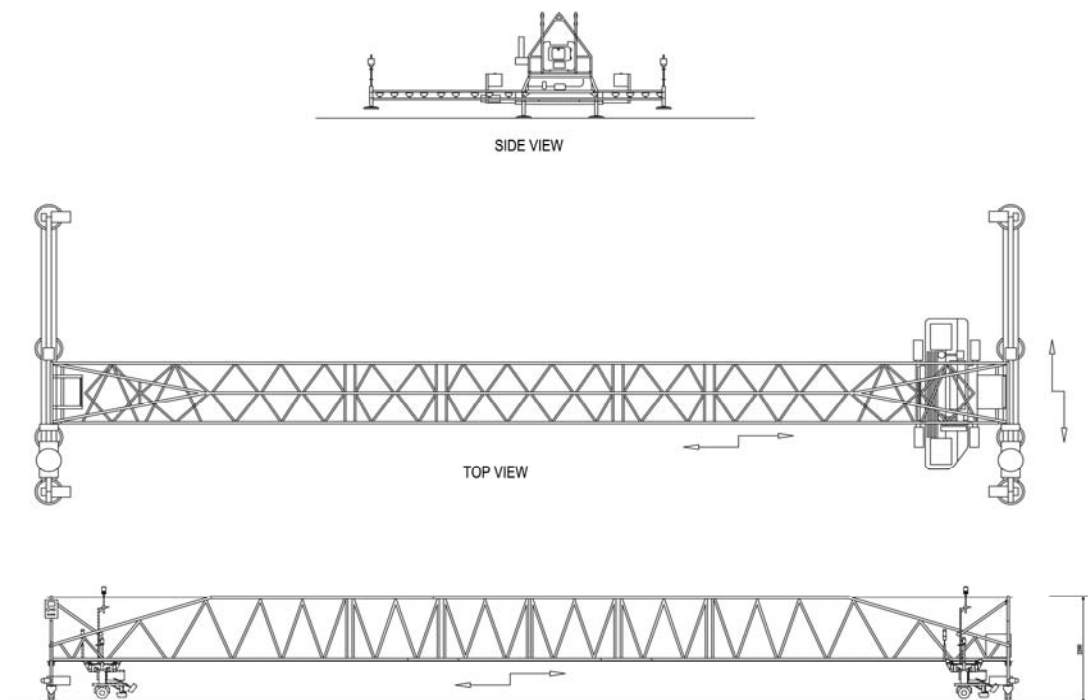

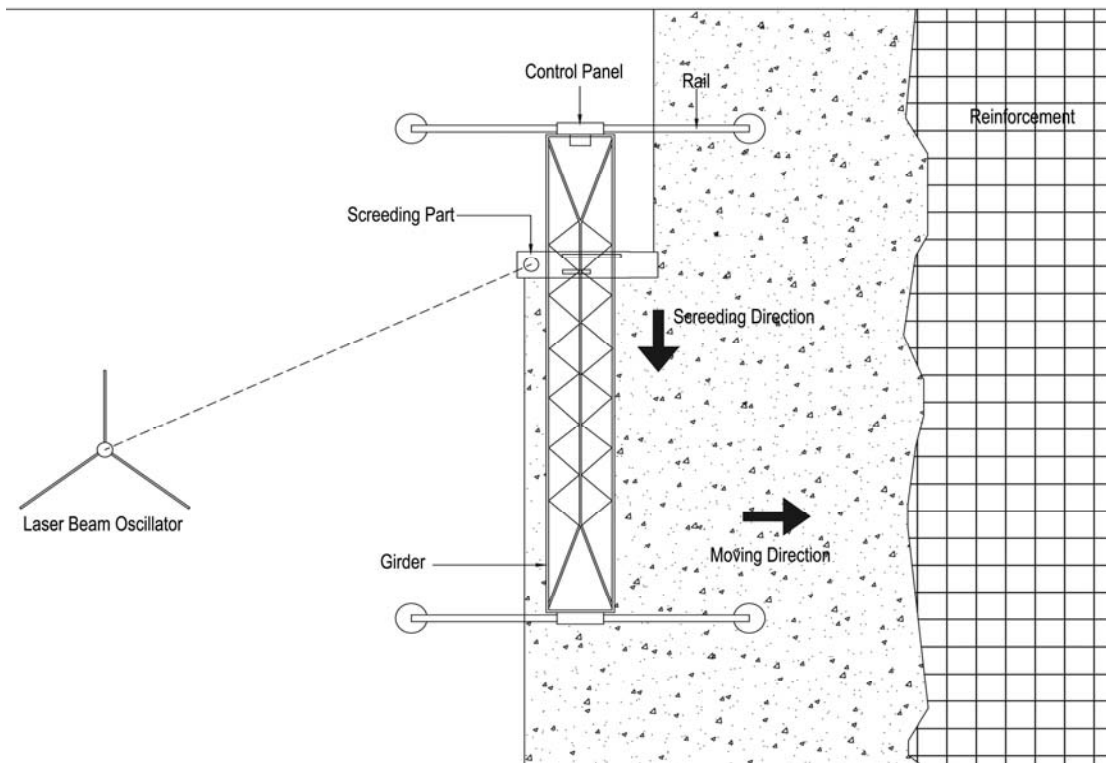

Automatic Floor Screeding Robot; Takenaka, (graphical representation according to **Construction Robot System Catalogue, 1999**)

4.1.6 Concrete Finishing

Floor finishing, seen from an ergonomic viewpoint, belongs to one of the most critical construction processes. Construction workers carry or guide trowel smoothers over several hours in a stooped posture. To relieve the construction workers from this work while maintaining consistency of construction quality, various companies have developed and deployed concepts for robots being able to execute that task: Flat-Kun (Shimizu, 800 square meters /hour), KoteKing (Kajima, 500 square meters /hour) Surfing Robo (Takenaka, 300 square meters /hour), Obayashi (Obayashi, 500 square meters /hour), Floor Traveling Robot MHE (Hazama, 300 square meters /hour). Each of these STCRs was able to operate on a floor where it was set up in any desired direction (i.e. not only move forward and turn, but to change position from a standstill without a curved turn). Cousineau & Miura (1998) stress that in Japan a skilled laborer in comparison was not considered to be able to process by the conventional method more than 120 square meters /hour).

The mobile unit was either docked as a separate module to the finishing or smoothing unit or, as was the case with some more compact systems, directly integrated with the finishing or smoothing mechanism, consisting in all cases of automatically controlled and operated rotating trowels. The robots were supplied with energy by either an electricity or generator system. The degree of autonomy ranged from systems with human-machine interfaces for tele-operation to systems that could generate motions themselves, to the preprogramming of the paths that the robot follows. In many cases, gyroscopes and rotating laser assisted navigation and motion planning on a low-level. After intensive research and development phase ended in 1985, the first concrete finishing/smoothing robots were commercially deployed in 1986 to finish the concrete floors of larger buildings, high-rises, power plant and other commercial buildings. The use of the robot systems became efficient once there was a floor plan with a working area of about 600 square meters (Cousineau & Miura, 1998) that could be processed without interruption. The following systems warrant highlighting in particular:

- Hazama's Robot: The displacement of STCRs on a floor or site, or the transfer of the robot from one floor to another, is a general weakness of STCRs. The Hazama company's system provided a solution to that problem that was not only the lightest, but allowed the robot to be dismantled into six 20 kg modules that was easily portable by human workers
- Kote King: The Kote King system was developed by Kajima and was finally outsourced in 1995 to Tokimec, which developed the Robocon system on the basis of this system. The Robocon system is still in use today. Robocon is lighter (Kote King 141 kg; Robocon: 68kg), quieter (Kote King 70 db; Robocon: 50 db), more productive (Kote King 500 m²/hour; Robocon: 800 m²/hour) and less costly (Kote King €40,000; Robocon: €20,000).

24	Floor Troweling Robot	Hazama
25	Concrete-floor Finishing Robot	Kajima
26	Concrete (interior) Floor Finishing Robot Flat-Kun	Shimizu
27	Concrete (exterior) Floor Finishing Robot Flat-Kun	Shimizu
28	Concrete-floor Finishing Robot Surf Robo	Takenaka
29	Concrete-floor Finishing Robot	Obayashi
30	Concrete-floor Smoothing Robot	Takenaka
31	Mobile Floor Finishing Robot	Kajima
32	Floor Finishing Quality Inspection Robot	Tokyu
33	Robotic Concrete floor Trowel	Robotus
34	Floor Troweling Robot "Robocon"	Tokimec

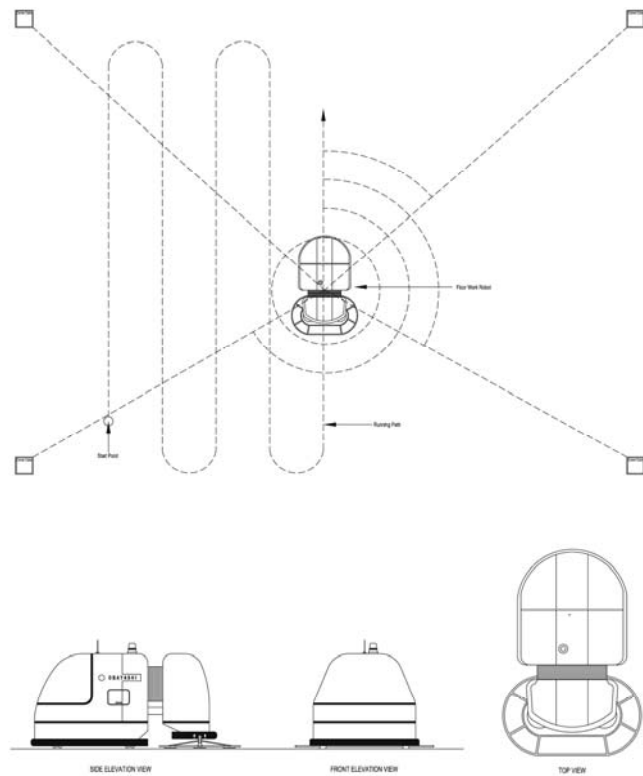

Concrete-floor Finishing Robot Surf Robo, Takenaka

4.1.7 Site Logistics

Logistics operations on conventional construction sites, in particular those where many low-level parts have to be handled, are numerous, time consuming and involve hard physical work. Nevertheless, logistics operations do not transform the product and thus do not directly add value. Logistics operations should thus be reduced to a minimum and a fast and continuous material flow between the productive entities ensured through JIT and JIS-like material delivery (see also 2.3). Site logistics involve the identification of material, collection of it, vertical and horizontal transport, and finally the material delivery to a given location on the construction site. The logistics robots of Ohbayashi and Mitsubishi, for example, brought pallets of panels and other materials to the installation site robots, and, in Japan, were able to communicate and synchronize with the prevalent (automated) logistics elevators. The Mitsubishi driverless transport system, for example, weighed 700kg, had a payload of 1300kg, a speed of 40m/minute and a turning circle of only 3 meters.

35	AGV for Construction Site	Shimizu
36	Mobile On-site Transportation Robot	Fujita
37	Robotic Fork Lift	Maeda & Komatsu
38	Robotic Vertical Lift	Maeda & Komatsu
39	On-site Overhead System (Floor Level, Horizontal)	Fujita
40	On-site Overhead System (Underground Level, Horizontal)	Fujita
41	On-site Monorail Overhead Logistics (Horizontal)	Kajima
42	On-site Automatic Lift	Kajima
43	AGV for Construction Site	Kajima
44	Mobile On-site Forklift Robot for Warehousing and Delivery	Obayashi
45	Robotic Horizontal On-site Fork Lift (Ground Level)	Takenaka
46	Robotic Horizontal On-site Transport Car (Floor Level)	Takenaka
47	Automated Vertical Lift	Takenaka
48	Robotic Construction Lift	Dept. of Architecture & Civil Engineering, Sungkyunkwan University

49	Mobile On-site Logistics Robot	Tokyu
50	Rail-guided Automatic On-ground Logistics	Kajima
51	Rail-guided Ground Level Concrete Distributor	Kajima
52	Modular Multi Robotic On-site Delivery and Working Platform System	Fujita
53	Automated Vertical Lift	Obayashi
54	Forklift Controlled by Humanoid Robot HRP2	Shimizu

4.1.8 Positioning of Components (Crane End-effectors)

The transport or lifting of parts or components by means of a conventional crane hook does not give many possibilities of control the position, balance and behavior of the lifted material. Cranes are thus mostly used only for logistics purposes, for transporting and placing material on the floor or area where it is required; for positioning and alignment operations, the components then have to be picked up by another system. A continuous material flow is thus barely possible. Positioning systems and robotic crane end-effectors upgrade conventional systems and methods, and allow precise pick and position/alignment operations.

55	Robotic Crane End-Effector	Taisei
56	Robotic Crane End-effector	Shimizu
57	Auto-shackle for Column Installation	Kwangwoon University & Samsung.
58	Robotic Crane End-effector "Robo-Crane"	NIST
59	Robotic Crane End-effector "Mighty Jack"	Shimizu
60	Autoclave	Obayashi
61	Autoclamp	Obayashi
62	Robotic End-effector	Obayashi

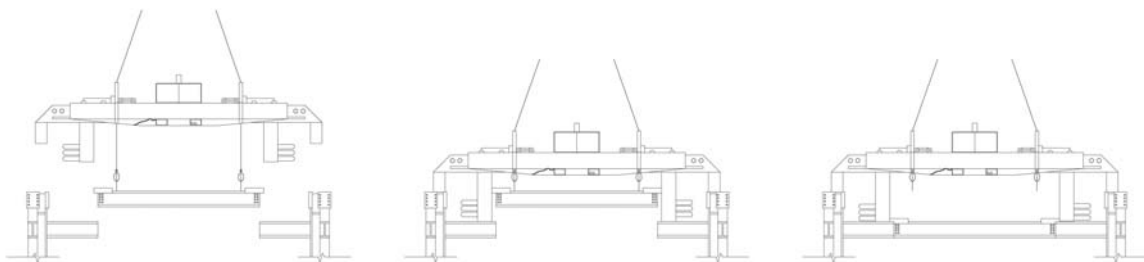

Robotic Crane End-effector "Mighty Jack", Shimizu

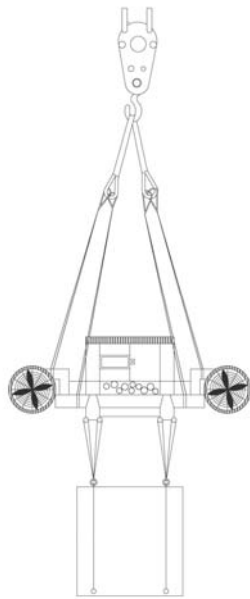

Robotic Crane End-effector, Taisei

4.1.9 Steel Welding

The construction of larger buildings built on steel as basic material for the bearing structure involves, in particular, a large total amount of welding lines. If the design of the posts and beams allows the reduction of the amount of variety of welding lines, welding becomes a highly repetitive operation suitable for being automated. Furthermore, conventional labor based welding damages – especially when the provided equipment is of low quality – in the long run human health severely. Automated welding is able to control and guarantee the quality of the connection of the welded parts better. Simultaneous automated welding on a beam e.g. from two or three exactly coordinated positions is even able to ensure that the steel component is not distorted and thus guarantees a high degree of accuracy within the constructed structures.

63	Steel Column Welding Robot	Shimizu
64	Steel Beam Welding Robot	Obayashi
65	Steel Column Welding Robot	Fujita
66	Steel Column Welding Robot	Obayashi
67	Steel Beam Welding Robot	Fujita
68	Small Sized Column Welding Robot "AUWEL 2"	Aamazaki

4.1.10 Facade Installation

Facade installation operations cover the positioning and adjustment of windows, complete facade elements or building exterior walls. Facade elements, in modern architecture and especially in high-rise construction, are decoupled from the bearing concrete or steel main structure and can thus be considered as a type of “infill” (for further explanation of F&I approach **see also 2.2**). Facade installation operations are complex operations that involve the accurate positioning of heavy parts or elements at locations that are difficult to access (e.g. high altitudes without scaffolding). This involves the risk of injury (and thus extensive safety measures) and of damaging expensive elements. Furthermore, the positioning and alignment of prefabricated facade elements requires precision and low tolerances. Since the 1980s, the growing trend of designing large buildings as monolithic structures repeating like or similar facade elements has provided a major argument for investment into the development of automated or robotic systems. Up to the present day, facade installation systems have been a hot topic in R&D departments, especially firms in Asia where high-rise buildings are becoming more and more pervasive, even in residential construction.

69	Curtain Wall Installation Shuttle Method	Fujita
70	Facade Element Installation Robot	Kajima
71	Robot for Positioning Facade Elements from Upper Levels on Lower Levels	Kajima
72	Facade Concrete Panel Installation Robot	Kajima
73	Automatic Facade Panel Installation using a movable Fixture (right Positioning)	Fujita
74	Facade Element in Place Pushing Robot (Fine Positioning/Alignment)	Fujita
75	Ceiling Glass Installation Robot	Hanyang University & Samsung
76	Facade Element Installation Robot	Hanyang University & Samsung
77	Roof Cover Installation Robot	Kumagai-gumi

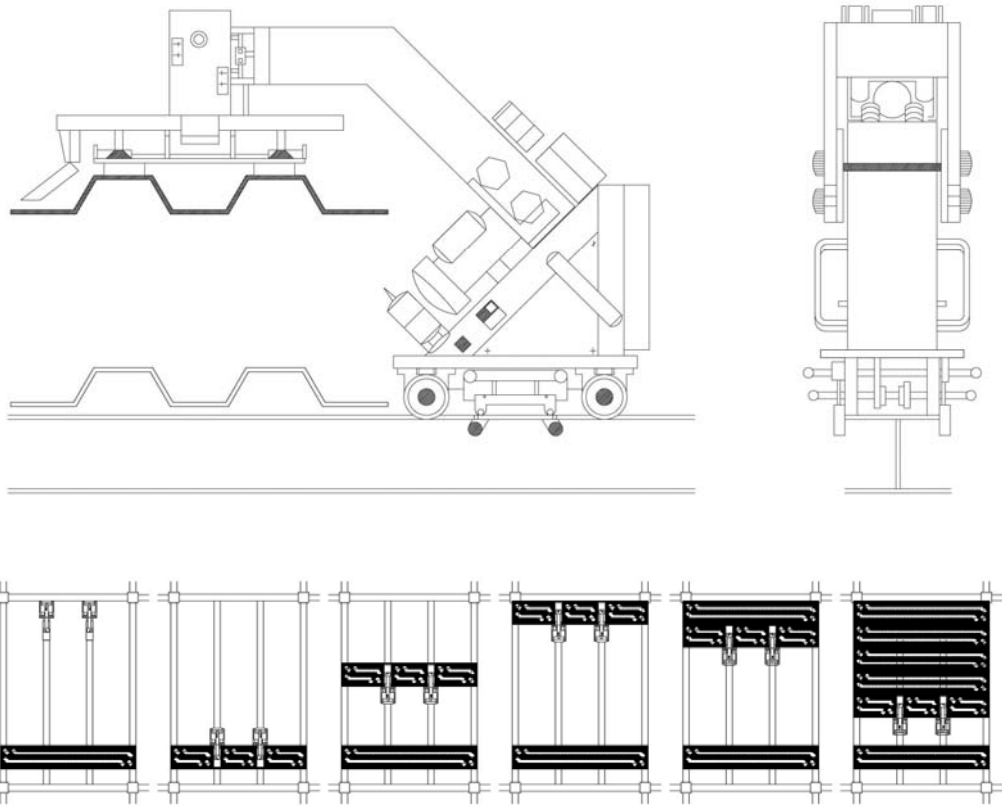

Roof Cover Installation Robot, Kumagai-gumi

4.1.11 Tile setting

Buildings of all types are often equipped with tiles made resistant to a specific climate and weather situation. In Japan single-family buildings, factories, offices and high rise buildings are regularly equipped with tiles (coming mainly from Inax or Toto). Tiles are relatively small building elements compared to the total surface area of a building, and huge amounts of tiles have to be laid by the same, repetitive process involving mortar, laying and tile positioning. The high amount of identical elements, the repetitiveness of operations as well as the fact that facades are in general difficult to access, makes the use of automated systems potentially interesting. Kajima's tile setting robot also shows that accuracy can be enhanced and that the laying of patterns can be accomplished without dramatically increasing the man hours.

78	Robot for Setting Tile Floor	Eindhoven University of Technology
79	Robot for Setting Tile Wall	Hazama & Komatsu

4.1.12 Facade Painting

Facade paint robots were developed to simplify the painting of building facades, which, even with scaffolding, are often difficult to of access. Facades of high buildings in particular are difficult to paint or re-paint during construction, as well as during operation. Facade painting robots have a particular advantage in keeping the quality constant. They usually have multiple spray nozzles; the spray area of the ink mist is in order to avoid streaking either encapsulated or hermetically covered elements, and the constant painting quality is specifically controlled by the precise control of the rotating spray nozzles, spinning speed and spraying pressure. A major advantage of painting robots is the fact that the workers are not exposed to harmful paint substances. STCRs for painting use different strategies to move along the facade:

- suspended cage/gondola systems
- rail guided systems
- systems moving along the facade by vacuum or other adhesion technology

The use of facade painting robots was not considered efficient below a facade area of 2,000 square meters (**Cousineau & Miura, 1998**). Facade painting robots were thus used primarily to paint large facades of high-rise buildings and larger types of commercial buildings. Facades to be processed were required to have a low degree of curving, and where possible, no corners or lugs which could hinder the operation of the robot. Furthermore, the design of the window frames, as well as the amount and area of covered by the windows, impacts applicability and efficiency of facade painting robots. Between 1984 and 1988, various companies produced facade painting robots (e.g. Shimizu, Kajima, Kumagai (KFR 1 and 2) Taisei (TPR 1 and 2) and Urakami. Shimizu and Kajima applied the principle of the suspended cage or gondola. Kumagai's system (developed by Urakami), moved a suction device along the facade by way of a vacuum. Taisei used a rail guided system and combined it with the gondola approach. The fastest of the systems (Kajima) worked with a speed of 290 square meters /hour, while spraying the base layer for the paint, about 200 square meter /hour for the main coat and 290 square meter /hour for the top coat.

80	Facade Painting Robot	Shimizu.
81	TPR-02 Facade Painting Robot	Taisei
82	Facade Painting Robot System	Kajima
83	Facade Painting Robot	Tokyu.
84	Facade Painting Robot	Kajima.
85	Automatic Balustrade and Balcony Facade Painting System OSR-1	Shimizu

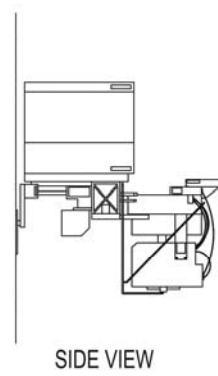
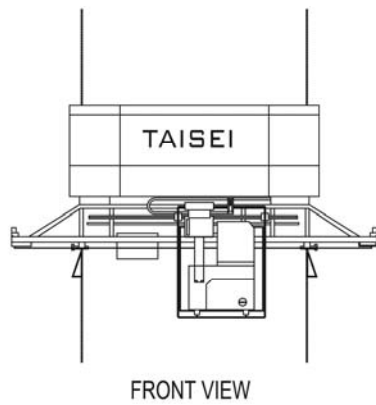
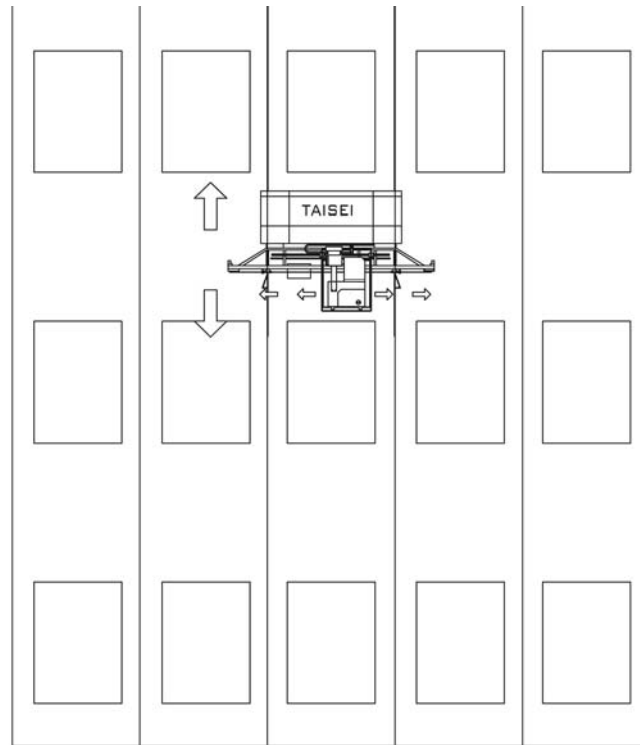

TPR-02 Facade Painting Robot, Taisei

4.1.13 Interior Finishing

Interior finishing work is, both in terms of ergonomics and in terms of productivity, unfavorable work, as cranes or other machines used to lift and position parts and components can rarely be used. Many interior finishing systems were deployed between 1988 and 1994, and the development continued in parallel to the development and deployment of integrated automated sites, especially as interior finishing robots were used within automated construction sites for finishing buildings. According to Cousineau & Miura (1998) ceiling floor panel installation robots, in particular, achieved only marginal improvements in terms of speed (e.g. CFR-1: reduction of time required for installing a panel from 3-4 minutes down to about 2.5 minutes) and human labor requirement (e.g. CFR-1: only one worker necessitated instead of two person teams necessitated). The following systems warrant highlighting in particular:

- The Taisei Boardman 100 was designed for indoor ceiling operation, and was able to position wall panels within a horizontal reach of 790mm to 1980mm.
- The Shimizu CFR-1, could be manually operated and tele-controlled and was able to flexibly perform panel (suspended ceiling) installation to a ceiling height of up to 3500mm. Due to its inbuilt compliance with the robot's gripper system, the robot was able to adjust ceiling panels into the correct position.
- The Komatsu LH robot series of handling systems could highly accurately position and adjust interior wall panels, glass panels, door frames, casing bodies and outside walls.
- The Tokyo ceiling panel installation robot not only positions and adjusts the panel, but can also fire nails into the panels to fix them to the underlying profile system.

88	Ceiling Floor Panel Installation Robot (CFR series)	Shimizu
89	Plumbing Part Positioning Robot	Komatsu
90	Interior Finishing Material Handling System (LH 30)	Kajima & Komatsu
91	Robot For Setting Concrete Columns (LH 50)	Kajima & Komatsu
92	Interior Finishing Material Handling System (LH 80)	Kajima & Komatsu
93	Robot For Setting Concrete Walls (LH 150)	Kajima
94	Panel Handling Robot	Kajima
95	Ceiling Panel Positioning and Nailing Robot	Tokyu
96	Ceiling Panel Positioning Robot	Taisei
97	Mobile Plasterboard Handling Robot	Komatsu

98	Interior Panel Handling Robot	Taisei
99	Wallpapering Robot	Komatsu
100	Mobile Robot for Installation of Heavy Components	Komatsu
101	Mobile Interior Finishing Robot	Lindner/TUM/ FAPS
102	Mobile Material Handling Robot	Komatsu
103	Mobile Material Handling Robot	Taisei
104	On-site Brickwork Laying Robot, SMAS	Japanese Research Institute
105	On-site Brickwork Laying Robot, BRONCO	Dackler
106	On-site Brickwork Laying Robot, ROCCO	Lissmac & Karlsruhe University
107	Brickwork Laying Robotic Drone	ETH Zürich (D'Andrea, Gramazia & Kohler).
108	Aerial Construction with Qaudrotor Teams	GRASP Lab, University of Pennsylvania

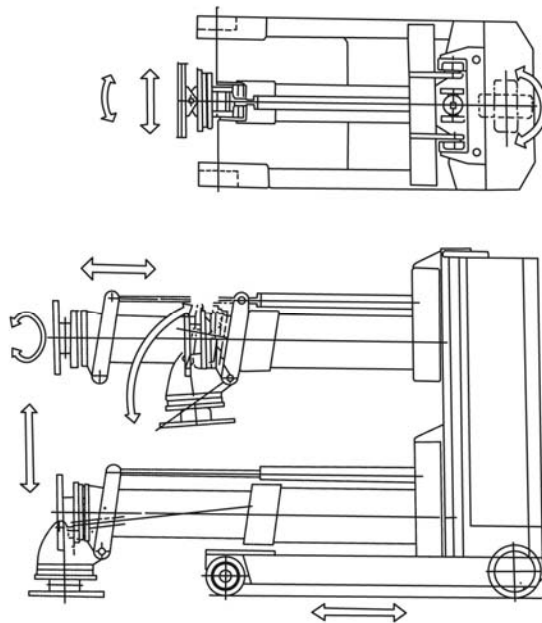

Modular Material Handling System LH series, Kajima & Komatsu

4.1.14 Fireproof Coating

In many countries building regulations demand that steel structures are covered with fireproof plates and/or fire preventing paint. Thus measurements can only be done after the steel parts and elements have been joined on site in order to be able to connect elements properly (e.g. by welding) and in order to avoid any damage to the fire prove coating through assembly operations. A shift of coating operations to upstream production steps, and thus to a structured factory environment where coating could be done with high efficiency, is not practicable. In Japan in particular, where earthquakes and a high rate of high-rise construction forces the extensive use of steel structures, the development and employment of automated and robotic systems that are able to coat the steel structure after it has been erected on site, are a logical step. Systems such as the SSR1, SSR2, and the SSR3 were largely autonomous and efficient, highlighting that those companies had continued to develop those systems over several generations.

109	Shimizu Fireproof Coating Robots “Shimizu Spray-painting Robot” (SSR1, SSR2, SSR3, SSR4 Hybrid)	Shimizu
110	Fireproof Coating Robots	Toda
111	Fireproof Coating and Rock-wool Spraying Mobile Robot	Fujita
112	Fireproof and Rock-Wool Spraying Beam-attached/rail guided Robot	Fujita

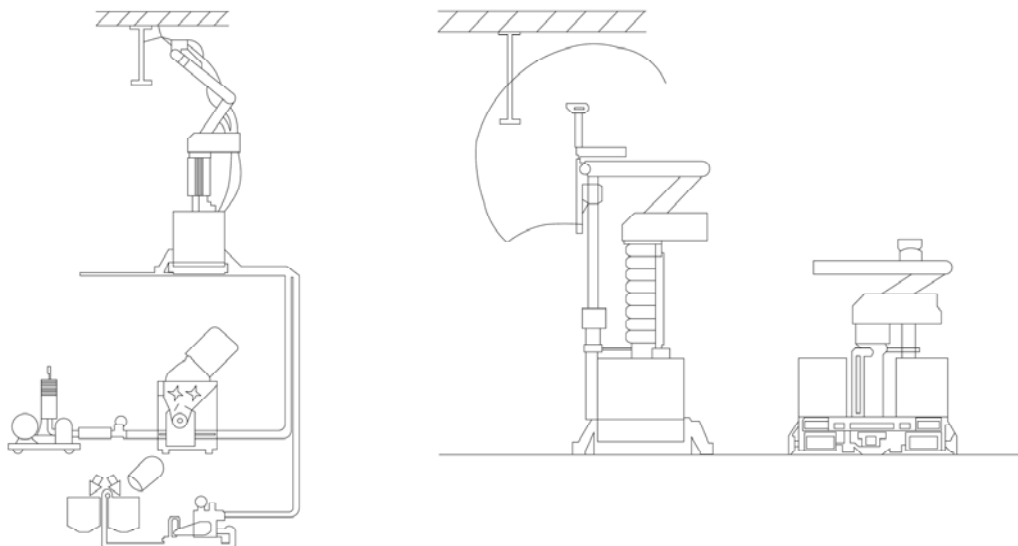

Fireproof Coating Robots (SSR1, SSR2, SSR3), Shimizu

4.1.15 Service, Maintenance and Inspection

Facades of high-rise buildings are in many cases equipped with tiles or other surface panels that have to be inspected regularly during the building's life cycle in order to detect structural damage, and in order to exchange tiles or panels that might fall from the facade to the ground. Typically, workers access those tiles or panels via cages or gondolas, suspended from the roof of the tower blocks. This work process was considered by Japanese construction firms as monotonous, inefficient and dangerous. Furthermore, at high altitudes due to wind noise the knocking sounds identifying damaged tiles or panels were difficult to classify. Therefore, with substantial financial commitment, inspection and maintenance robots for facades were developed that were able to autonomously execute this monotonous and dangerous job, and was able to deliver more reliable analytical data. For the inspection of the facade of a 40 m high building (3000 square meter facade) an inspection robot needed an average of 8 hours, including approximately 1 hour for preparation, configuration, conversions, dismantling and cleaning of the robot (**Bock et al., 2010**). According to a study conducted by the Architectural Institute of Japan (**AIJ, 1990**; also addressed by **Cousineau & Miura, 1998**) a major weakness of facade inspection robots was the large amount of human labor and set-up time required to install, program, calibrate, supervise and uninstall those systems in an unstructured construction environment.

Besides the above mentioned inspection field, the following areas can be covered by service, maintenance and inspection robots:

- Cleaning and housekeeping
- Rehabilitation of humans
- Lawn mowing
- Surveillance
- Medical applications
- Applications for an ageing society
- Guides
- Services in offices
- Fire fighting
- Search and rescue

113	Facade Inspection Robot	Kajima
114	Facade Inspection Robot	Taisei
115	Rail-guided Facade Cleaning Robot	NihonBiosh.
116	Desk/Chair Arrangement Robot	Fujita,
117	Fire Fighting Robot	Japanese Research Institutes

118	Rail-guided Facade Cleaning Robot “Canadian Crab”	Shimizu
119	Pipe Inspection Robot	Japanese Research Institute
120	Maintenance and Rescue Robot System	Komatsu
121	Louvre Facade Cleaning Robot	Comatec Robosoft
122	Robot for automatic performance measuring of aeration system (air volume testing)	Shinryo Corporation
123	Aeration System Inspection Robot	Fujita
124	Tile Facade Inspection Robot	Obayashi Corporation & Waseda University
125	Facade Element Inspection Robot	Obayashi
126	Automatic Facade Cleaning System for the Glass Hall of the Leipzig Trade Fair	Fraunhofer FHG
127	Facade Washing Robot	Universidad Politécnica de Madrid, Fraunhofer-Institut für Produktionsanlagen und Konstruktionstechnik,
128	SIRIUSC – Automatic Facade Cleaning System	Fraunhofer FhG, Dornier Technologies
129	Rail Guided Modular Facade Cleaning Robot	Department of Mechanical Engineering, Korea University, Seoul
130	Automatic Rail Guided Window Washer	Nihon Bisoh Corporation
131	MTV-1 Mobile Base Equipped with Floor Cleaning Module	Shimizu
132	Self-climbing Outer Wall Inspection System for High-rise Apartments	Obayashi

4.1.16 Renovation and Recycling

As in renovation and recycling, the use of standardized parts, prefabricated components and (heavy) construction equipment is difficult, those operations are highly labor intensive. In 1997, German construction had an interesting turning point: the construction volume concerning renovation and modernization exceeded the construction volume of new constructions. Today, the discrepancy is even larger than before (New Construction: €50 billion, Modernization €85 billion) and it is considered to be certain that this trend will take hold (**Bock & Linner, 2008**). However, also in Japan where buildings usually have shorter life cycles, the trend is heading towards renovation in order to save resources. The automation of renovation and recycling operations, on the one hand, promises tremendous improvement concerning labor productivity, but on the other hand will demand flexibility higher than that built into other STCRs.

133	Facade Delamination Robot	Takenaka
134	Concrete Surface Removing Robot	Shimizu
135	On-site Material Recycling Robot "Garapagos"	Komatsu
136	Post Disaster Clean-up Robot	TMSUK
137	Chimney Cleaning and Dismantling Robot	Toda
138	Green Cutting Device with automatically controlled Water Cutting Jets	Kajima
139	MTV-1 Mobile Base Equipped with Floor Grinding Module	Shimizu
140	Automatic Carbon Fiber Wall Wrapper	Obayashi

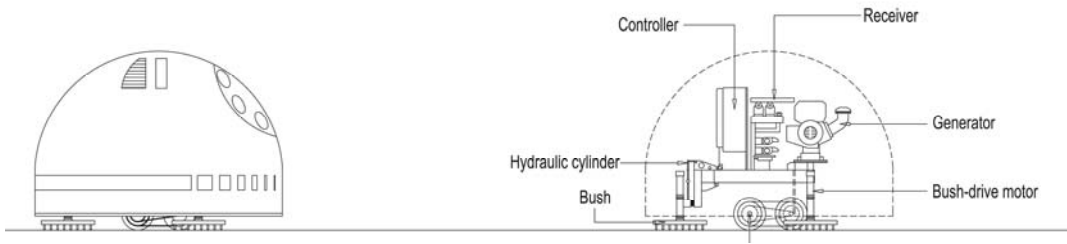

Concrete Surface Removing Robot, Shimizu, (graphical representation according to **Construction Robot System Catalogue, 1999**)

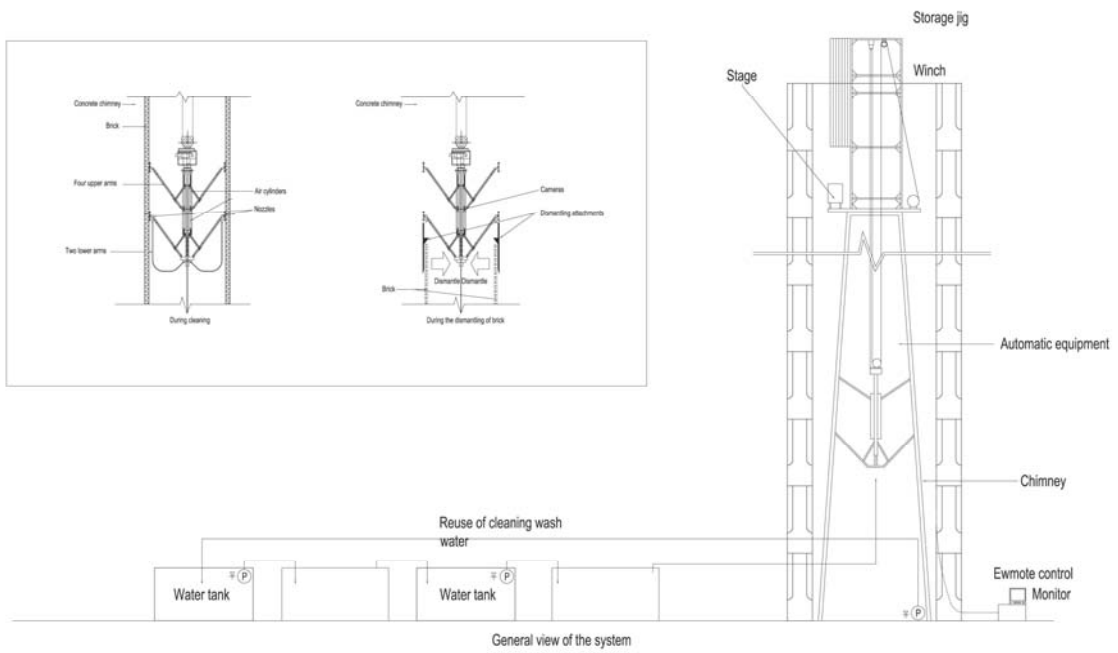

Chimney Cleaning and Dismantling Robot, Toda (graphical representation according to **Construction Robot System Catalogue, 1999**)

4.2 Transition and Technological Reorientation towards Integrated On-site Manufacturing (ONM)

After the evolution of industrialized and automated LSP till the 1970s (see 3.2), and the development of robots substituting tasks on the construction site from 1978 onwards (STCRs; see 4.1), from 1985 onwards, concepts emerged which envisioned automated site factories. Those concepts combined BCM technology (processing of prefabricated low-level to medium-level components instead of parts in order to reduce complexity on-site), STCRs (mainly for interior finishing operations) and moving or stationary site factories which were able to assemble the building's main structure (such as steel frames or concrete structures) almost automatically. As those site factories not only automated parts of the construction process but also integrated prefabricated component technology, STCRs, along with other elements that emerged during the 1980s (refined automated on site logistics, climbing robots, site cover technology, simulation and real time monitoring technology, ROD), they are referred to in this thesis also as integrated automated construction sites. Almost all institutions involved in the automation and robot technology from 1978 onwards switched their focus towards this new concept during the 1980s.

The reasons for this change in the general R&D direction were manifold. A major reason was that construction firms realized that STCRs that were not networked or embedded in a larger SE turned out to be incompatible with the way buildings were designed and built. STCRs substituted individual, mostly trades-related processes on-site. Common to all is that they were designed to execute certain tasks while activities of construction workers were not allowed to interfere significantly with the robots' activities. However, it turned out that under these premises, only very few robots could be used efficiently or economically. The constraints for the workers, the necessary safety regulations, coupled with the unforeseen, unpredictable, and dynamic processes at the site, set rigid boundaries for the individual robots working in parallel to the normal construction sequence.

Although STCRs boasted high working speeds (and thus high productivity on a machine level), significant time had to be spent on-site for preparation, configuration, transportation, programming, adjustment of spray volumes or injection pressures. Also, in most cases, the use of such systems was not considered in the design of the building (e.g. floor plans were not adjusted to the operation requirements of concrete flow finishing robots) or with the conventional job site installation (for example, no parking or recharging stations for robots were foreseen or available). Furthermore, STCRs were not compatible with or integrated with upstream or downstream processes, and any productivity gains were equalized.

Apart from the mentioned incompatibilities STCRs caused on (conventional) construction sites, the emergence of concepts for integrated sites was also nurtured by the new technological possibilities. Important for the integration of such systems into larger and coordinated automated systems was the development of systems which allowed the controlling and monitoring of an uninterrupted flow of information and material on-site between individual automated (and also non-automated) entities that are involved in the

(final) assembly of the building on-site. The emergence of concepts for integrated sites can also be explained from an evolutionary point of view. Most technological systems evolve from an array of single and disconnected entities to more complex systems, thanks to information and communication technology. Also, in many firms or industries, the movement from workshop-like production with individual and only loosely coupled production entities or stations, to flow-line-like or production-line-like systems, with stable processes and continuous material flow was part of the evolution of those industries (e.g. automotive industry, computer industry).

From 1985 onwards, a working group set up by the Architectural Institute of Japan (from 1983) around Hasegawa, WASCOR group (WASeda CONstruction Robot group) members and joined by researchers of all major Japanese construction firms and equipment suppliers, intensified research in the development of site factories that would provide the SE required for automation and the efficient integration of STCRs and prefabricated components optimized for automated construction (see also ROD, 6.2). In 1989, Shimizu tested the subsystems of the first integrated automated site on its research site with an experimental construction. In 1990 and 1992 the working group released two reports (1990: Robotic Technology for Building Production; 1992: Construction Automation) which provided the major Japanese construction companies with guidelines for the development and deployment of integrated, automated construction sites during the 1990s. In 1993 Shimizu started to use its so called SMART (Shimizu Manufacturing System by Advanced Robotics Technology) commercially and all other major Japanese construction firms followed during the next decade.

4.2.1 Development and Refinement of Automated On-site Logistics

On site logistics can be considered as a kind of internal factory logistics. The development and refinement of automated on-site logistics systems was a key element of the step-by-step evolution of integrated automated construction sites. On-site logistics systems enabled the connection of individual work areas and work stations, and thus to advance from unorganized workshop-like activity (including STCR activity) to more organized (e.g. flow-line-like) manufacturing forms. The connection of workstations, work areas, machines and STCRs by on site logistic systems allows a factory-like controlled, continuous and uninterrupted material flow. This can be seen as the basis for stable and productive “manufacturing” processes on the construction site. On-site logistics systems allow individual robots or groups of robots (e.g. ground based factories) to be connected in terms of material flow with the positioning and assembly systems (e.g. SFs).

On site logistics systems allow the optimized utilization of advanced and costly high-tech equipment (STCRs, robotic overhead cranes, etc.) as they guarantee their continuous and uninterrupted operation by a supply of material. Within the analysis and discussion of STCRs, various exemplary, automated or robotized site logistics systems developed from 1980 onwards, and which formed the basis for high performance logistics systems later deployed on Automated/Robotic On-site Factories, were outlined. Fujita’s automated

facade panel installation system was the first deployed system where refined logistics systems combining horizontal and vertical material transportation were used to directly link an on-site GF (on-site prefabrication of panels from parts and components) with the final assembly and positioning of the panel at the building's facade (*Figure 4-2*) and other concepts followed (*Figure 4-3*).

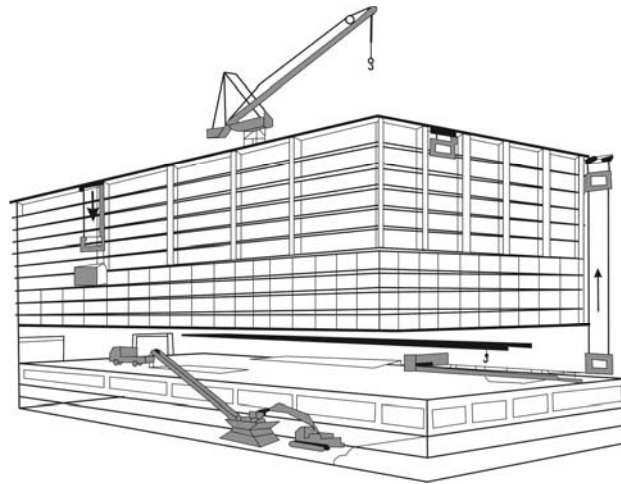

Figure 4-2: Integration of Fujita subsystems and STCRs (visualization according to **Construction Robot System Catalogue in Japan, 1999, p. 223**)

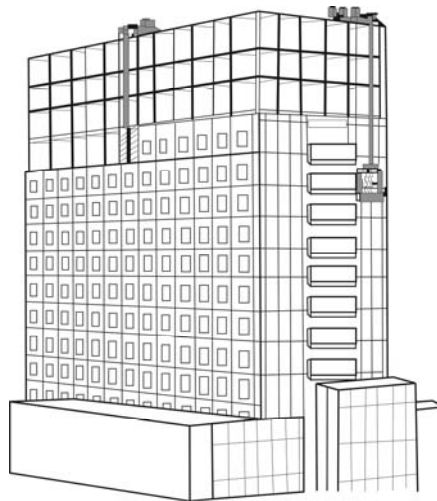

Figure 4-3: Concept for automatic facade lifting, positioning and finishing by Japan Industrial Robot Association (visualization according to **Hasegawa, 1999, p. 245**).

4.2.2 Development of Climbing Robots

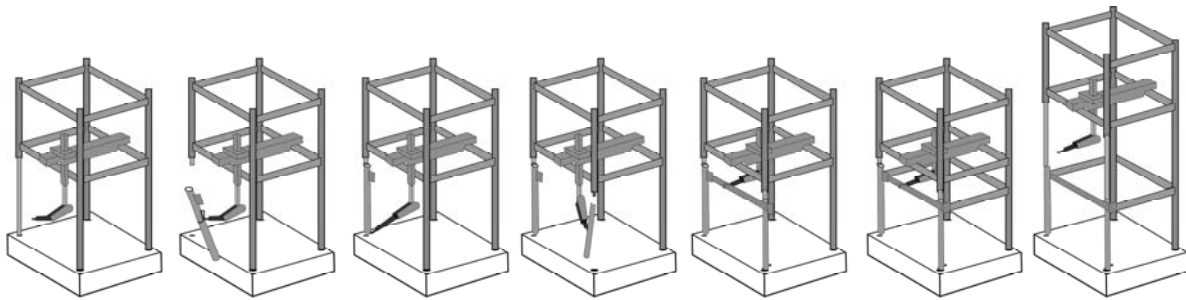

Figure 4-4: First concepts of a combination of a climbing mechanism with a robotic manipulator, allowing floor-by-floor installation of columns and beams (visualization according to **Obayashi, H. Teraoku**)

Climbing mechanisms are an elementary technology present on all integrated automated construction sites. They allow the controlled or autonomous movement of the means of production (factory covers, equipment, working platforms) with the general working direction (e.g. vertical related to high-rise construction). From 1985 onwards, slip forming technology was refined, automated and advanced towards systems that allowed automated climbing of working and equipment platforms. First concepts of a combination of a climbing mechanism with a robotic manipulator were developed (see *Figure 4-4*). Besides the climbing mechanism itself, technology (software and hardware) to precisely control jacks, measure positions (for example of systems or factories that are moved by the climbing mechanism), and for automated self-alignment of those systems and factories by the jack system was developed by researchers.

A special type of CS aimed – in contrast to other CSs – not at raising or moving the working platforms, but the produced structure, so that the construction process takes place on the ground level. Such concepts follow the traditional way of building wooden buildings by first constructing the roof before pushing it up. A prototype for a modern version of such a system is Fujita's Arrow Up system (*Figure 4-5*). The principle of this construction system is to finish a steel structure in such a way that all assembly work can be done on the ground floor level. A stationary, temporary frame with press cylinders serves as a template around which the steel frame structure for each floor is erected and then pushed up. The system was designed to erect the steel structure of vertical parking garages which are typical for Japan. The advantages of such a push-up strategy were seen in improved working conditions and simplified material handling. For commercial use, it was necessary to be able to build over ten floors. In particular Kajima, Sekisui Hose and Skanska later on deployed such systems in combination with robot technology for the construction with steel and concrete components (see **5.2**).

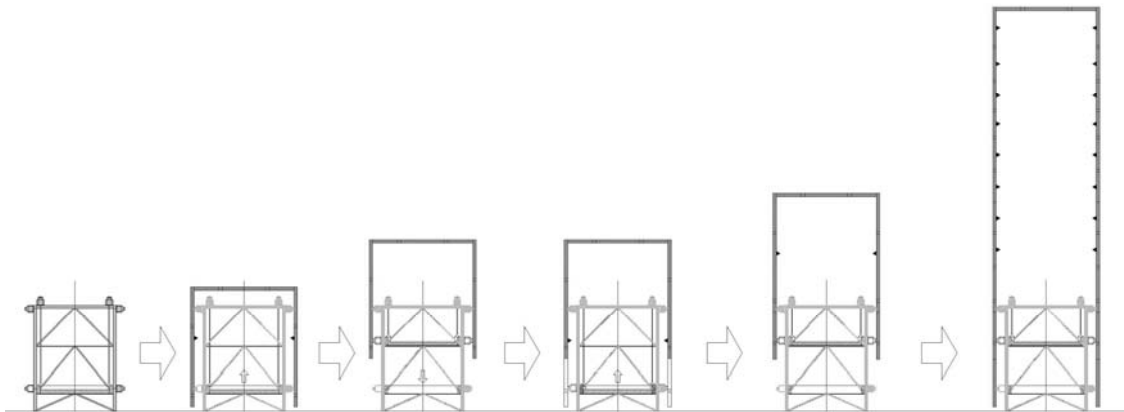

Figure 4-5: Fujita's Arrow Up allowed the subsequent push-up of a steel structure assembled on a ground floor level (visualization according to **Construction Robot System Catalogue in Japan, 1999**).

4.2.3 Refinement of Site-cover Technology

Site-covers ensure a work space unaffected by the weather. Furthermore, they allow for a workspace to be illuminated properly (at night, for example) and ensure that the noise of work activity does not disturb the neighborhood (at night, for example). The cover frames can – if dimensioned properly – provide a carrying frame for (automated) logistic systems, overhead cranes and positioning systems. Site-covers reduce the amount of unforeseen events (and thus negative impacts) on the organization on-site. They are the basis for creating a factory-like SE on-site. Both in Russia and in Germany, from the 1930s onwards, sites were sometimes covered in order to allow the use of the workforce during the whole day (24 hours) in several shifts, over the whole week (“24/7”), and during the whole year (to enable both summer and winter construction). In pre-war and during war time in particular, this approach was supposed to increase speed and efficiency of strategically important construction projects. Construction-like site-covers with integrated logistics and crane systems were also developed from that time onwards both in aircraft manufacturing and ship building (for further information, see **3.3.2** and **3.3.3**). During the 1980s, in Japanese civil engineering projects, such as in the construction of power plants or infrastructure projects, site-covers were increasingly deployed as systems integrated with and thus refined by automated logistics, automated overhead cranes and other automated machines (*Figure 4-6*).

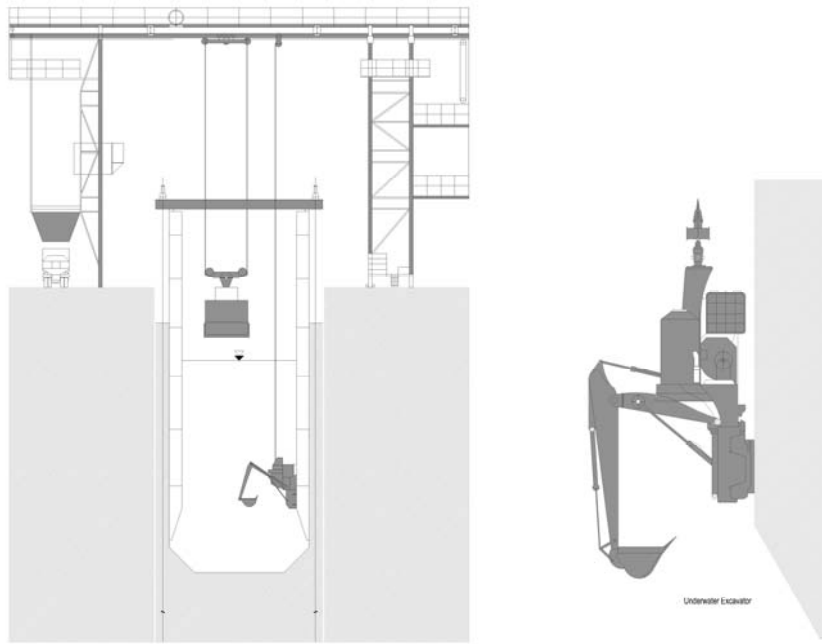

Figure 4-6: Super Open Caisson System (SOCS) conducted jointly by 13 companies from the end of the 1980s onwards. The spanning and covering of on-site work by a gantry-type site factory, integrating multiple automatic subsystems, is shown (visualization according to **Construction Robot System Catalogue in Japan, 1999**).

4.2.4 Introduction of Simulation and Real-Time Monitoring Technology in Construction

During the 1980s, major Japanese LSP companies introduced Enterprise Resource Management Systems (e.g. Sekisui Heim's Heim Automated Parts Pickup System, HAPPS, **see also 3.2**) into construction that were able to generate material lists (Bill of Materials) as well as work procedures, logistics operations and information for machines. At the same time, manufacturing industries relying on automation, such as the automotive industry, started to develop software tools that allowed them to simulate the production process (body in white assembly) in advance. From 1985 onwards, research activity increasingly aiming at using simulation, Enterprise Resource Planning (ERP) and manufacturing process-monitoring technology not only off-site in controlled factory environments, but also on the construction site. For the evolution of integrated, automated construction sites, the development of the aforementioned simulation, control and monitoring tools were just as important as the development of the machines and robots themselves, as automation on-site demanded:

1. That the construction process (developing production/manufacturing process) be planned and scheduled in detail.

2. That the deployment of complex and costly robot systems could be simulated and optimized.
3. That the material flow should not only be executed physically by a logistic system, but should be controlled on an informational level to achieve JIT/JIS delivery of exactly the demanded components on-site.

WASCOR, the central institute directing the construction automation attempts during the 1980s in Japan, Computer-Aided-Engineering Systems and Computer Aided Management Systems were seen as complementary to and necessary in the deployment of construction automation. Since the 1990s, Shimzu, as well as other companies, have developed simulation tools which allow the simulation and optimization of construction processes on-site. Most companies that deployed automated construction sites used such tools to optimize the configuration of the Automated/Robotic On-site Factory (for an examination of those tools, see analysis of subsystems of Automated/Robotic On-site Factories in **5.2** and **5.3**). Shimzu even developed a simulator that allowed the simulation and optimization of the disassembly of the site factory after completion of the building (see **5.4.2**).

4.2.5 Introduction of Robot Oriented Design strategies in Construction

From 1985, in light of the continuous deployment of more and more robots and automation technology on construction sites in Japan, various institutions (researchers, companies and universities) started to adapt the design of buildings (structure, modules, components, joining systems, etc.) in order to support and simplify the use of robots on-site, and thus to enhance their efficiency. Approaches that aim at redesigning the product in order to allow for more efficient processes and the efficient use of humans and machines in manufacturing were pioneered before 1985 by Toyota Motors. The TPS applied strategies that were aimed at optimizing designs for failure free assembly, JIT logistics and processing by automated systems and robots (for further details, see **2.3** and in particular **6.2.1**). Furthermore, traditional Japanese timber construction, as well as modern Japanese LSP (starting in the 1970s), relied on systemized building designs that simplified and reduced on-site construction efforts (for further information, see **3.2.1**). From 1985, a working group built around Hasegawa and the WASCOR group developed strategies for changing building design to support the operation of automated systems and robots on the construction site.

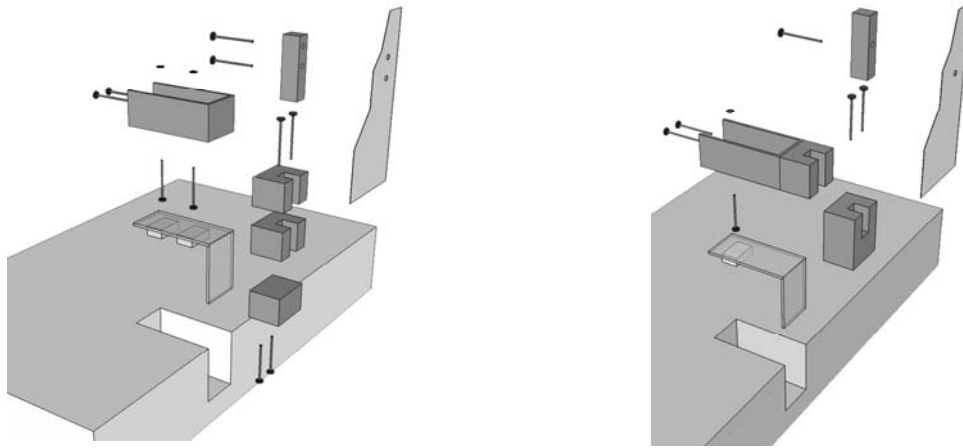
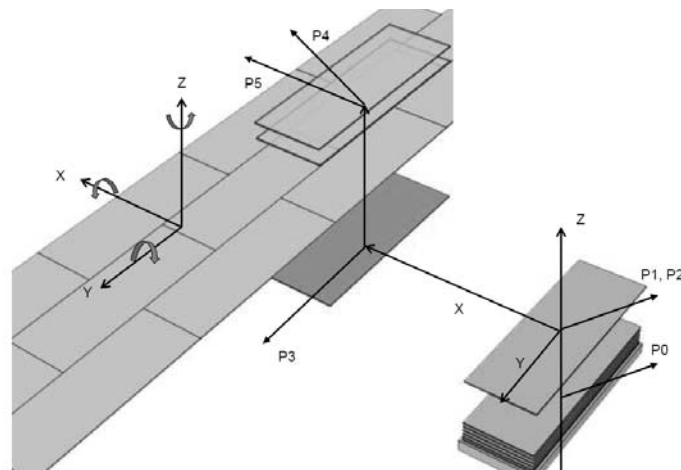

Figure 4-7: Development of method of ROD by Bock, T. from 1985 onwards within WASCOR. Reduction of complexity of assembly process by reduction of parts and redesign of component structure. (visualization according to **Bock1988**)



P 0: Start Position, P1: Picking up Panel, P 2: Rotate Panel, P 3: Deliver Panel, P4: Lift up Panel, P4: Positioning of Panel (visualisation according to **Hasegawa et al., 1992**)

Figure 4-8: Analysis of positioning process and related kinematics of the installation of a ceiling panel as a basis for automation. Researchers started to develop a construction specific kinematics science and to identify and specify DOFs, robot motions and robot trajectories necessary to install specific parts and components on the construction site. (Picture taken from Hasegawa et al., 1992)

The basis for the development of WASCOR's strategies was the research activity (and later on doctoral thesis) of Bock (**1989**). He developed the concept of ROD at the University of

Tokyo under the supervision of Professor Uchida (who also a decade before supervised the development of Sekisui Heim's M1, the first building kit designed for production line based mass production). ROD aimed at the reduction of complexity of assembly process by the reduction of parts and the redesign of component structures as a prerequisite for the application of automation and robotic son the construction site (*Figure 4-7*). In parallel, researchers started to develop construction specific kinematics science and to identify and specify the DOFs, robot motions and robot trajectories necessary to install specific parts and components on the construction site (*Figure 4-8*).

4.2.6 First Concepts for Integrated Sites: Cooperating Single-task Construction Robots

After several hundred STCRs had already been deployed, concepts evolved during the 1980s that envisioned various STCRs working in parallel, cooperatively and remotely controlled on the construction site. The concepts of tele-existence and tele-control of multiple construction machines were pioneered by Professor Susumu Tachi at the University of Tokyo in the 1980s. Applications for tele-operated construction machines (excavators and trucks) had been used in Japan in the real world, for example during the Mount Unzen disaster incident, where a volcanic eruption covered a large area with dust and remotely controlled robotic construction equipment was used to clean the area. Concepts and knowledge about tele-operation, and the remote control of groups of construction equipment inspired concepts for the control of multiple cooperating construction robots on the building construction site (*Figure 4-9*, *Figure 4-10*, *Figure 4-11*, *Figure 4-12*).



Figure 4-9: Multiple cooperating construction robots are operated by a single human supervisor from a central box, Vision Sketch (picture courtesy of **Japanese Research Institute, 1980**)

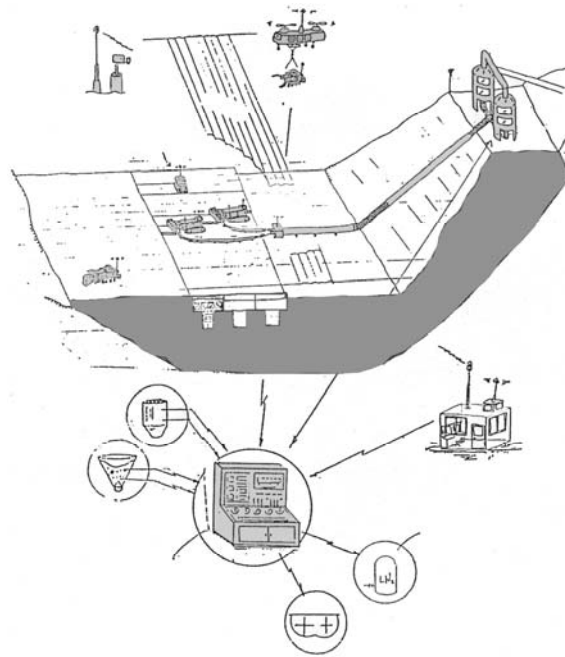

Figure 4-10: Multiple robots cooperating in damn construction. Concept by Shimizu (visualisation according to a **Shimizu concept study presented on 5th ISARC**)

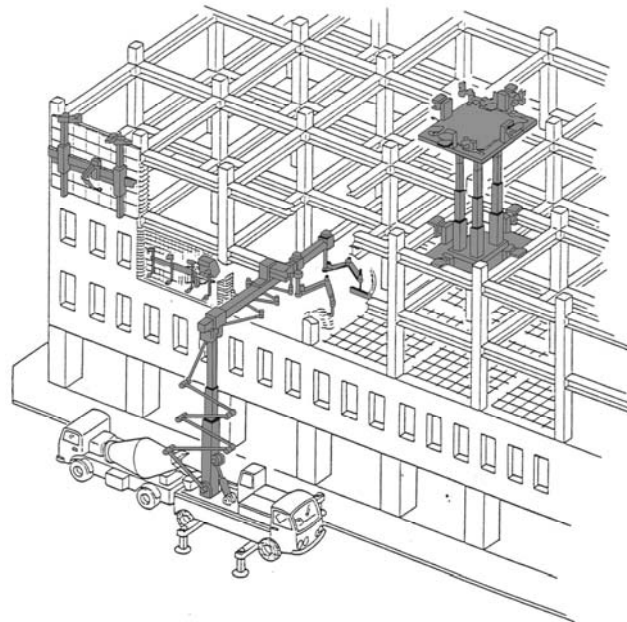

Figure 4-11: Integration and cooperation of several robotic systems on the construction site to construct a reinforced concrete based building (visualization according to **Hasegawa, 1985**)

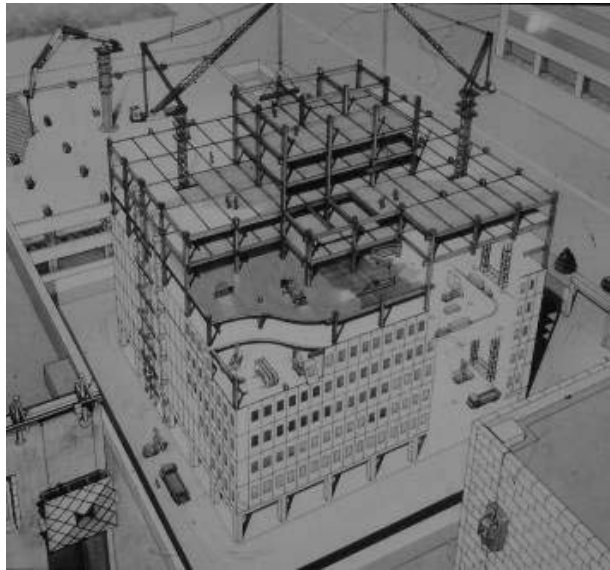

Figure 4-12: Integration and cooperation of several robotic systems on the construction site to construct a building on-site. Concept discussed within WASCOR (picture courtesy of **Bock**)

4.2.7 First Concepts for Integrated Sites: Factory Approach

In the second half of the 1980s more and more concepts evolved that analyzed the possibility of installing a structured work place or moving factory on construction sites. In contrast to the concept of networked, tele-operated and cooperating STCRs (see previous section), those approaches fused assembly and logistics systems more with the covering frame structures and focused, in contrast to the concept of cooperating STCRs (primarily used for facade installation and interior work), more strongly on the erection of the building's load-bearing main structure (*Figure 4-13, Figure 4-14, Figure 4-15*). Later, the first commercially deployed integrated, automated construction sites fused both approaches.

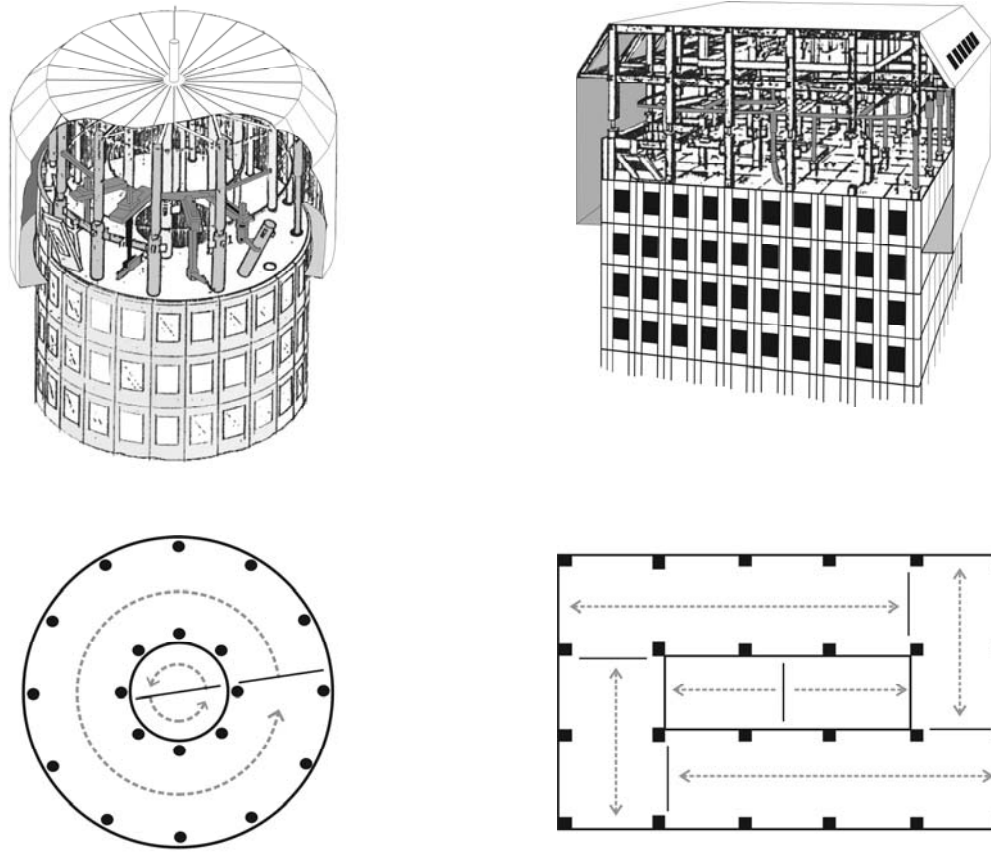

Figure 4-13: First concept studies for on-site SF and arrangement of OM system “Automatic Building Construction Floor” (visualisation according to Obayashi Research Institute, **Teraoku**)

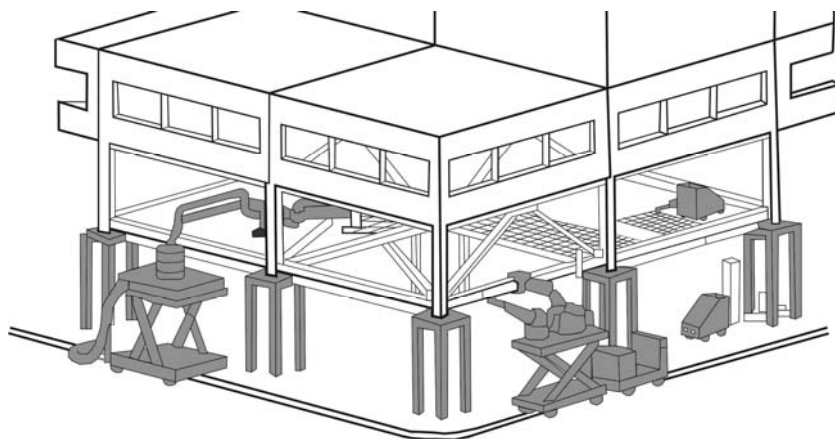

Figure 4-14: First concept studies for on-site GF and building push-up approach (visualisation according to Fujita, **Fukuda**)

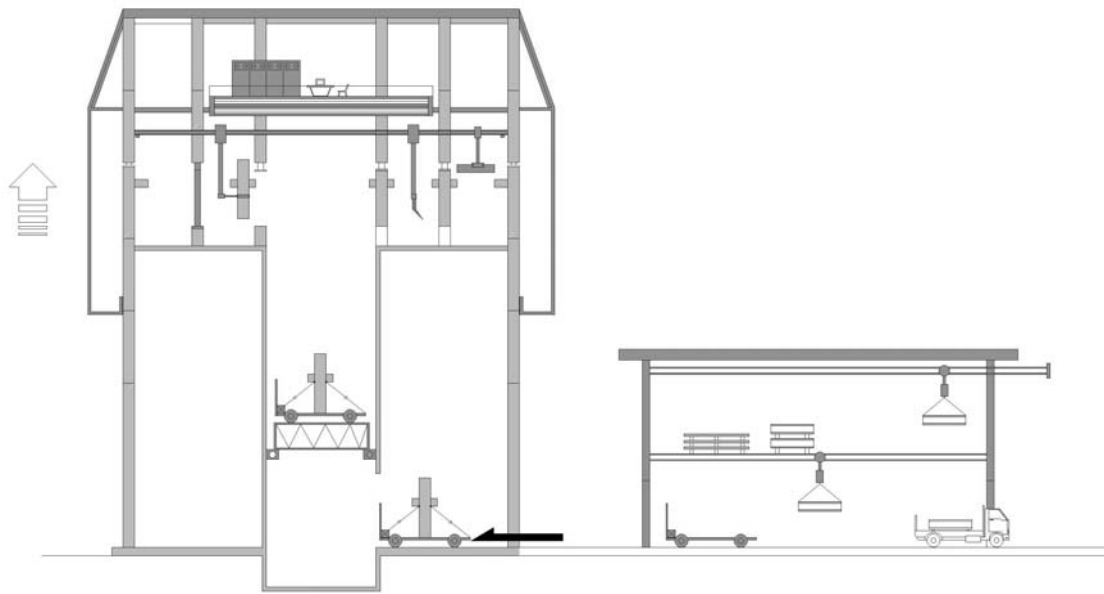

Figure 4-15: First concept studies for Super Construction Factory (SCF) approach. Integration of ground processing yard, VDS and SF and OM to a JIT/JIS component assembly system on-site (visualisation according to Shimizu, **Mori**)

4.3 Conclusion: From standalone Solutions to Systems integrated by Structured Environments

The Shimizu Corporation was the first Japanese construction company to transfer their experience of 12 years of construction robot development to the concept of a fully automated, integrated building construction site. Already in 1989, at the research site of the construction company Shimizu Corporation, subsystems of the SMART (climbing mechanism, overhead assembly robots, logistics system) were tested with the construction of an experimental building (*Figure 4-16*).

Approximately five years of development and a financial outlay of more than €12 million were necessary in order to operate prototype sites with SMART (Shimizu Manufacturing system by Advanced Robotics Technology) in 1990 and 1991. SMART integrated a moving, combined logistics and assembly system in an SF for steel structure erection with STCR technology for interior finishing. The SMART system was used commercially for the first time in 1991 for the construction of the 20-storey Juroku bank in Nagoya (for further details on this system, see analysis of this system in **5.2.1**). In the experimental construction site, the automated construction process was limited to the simulation of the positioning and welding of a building's steel skeleton, the positioning of precast concrete floor elements and the positioning of exterior and interior wall elements. A digital management system allowed real time control of the site, the automated logistics (vertical and horizontal distribution of components as e.g. columns), and the automated welding process.

All in all, it can be concluded that development of Automated/Robotic On-site Factories was based on the insight from 1985 on that the newly developed machine technology in form of STCRs was not able to provide a solution for the improvement of construction processes. STCRs were too task specific, conflicted with conventional construction work on site. Furthermore, aspects of continuous operation and material supply could not be addressed by them. STCRs only addressed sub-problems of the construction process, but did not address the main challenge in construction which is to build up the buildings main structure (in this thesis also referred to as "frame", for more details on F&I strategies, see **2.2**) on the construction site— along a main working direction - and to equip it with technical infill and with finishing. The erection of a building can be considered as a complex assembly process. As in any other industry, the systematization, mechanization and finally automation of complex manufacturing processes can only be achieved by the cooperation of multiple machine systems with other means of production in a SE.

STCRs, from a technological point of view and in respect of the improvement of productivity related to specific construction tasks is an enormous improvement. However, from a larger organisational point of view which considers the whole assembly process on-site, the application and integration of STCRs into the construction process could still be considered as workshop-like production with individual and only loosely coupled production entities or stations. After the evaluation of the first series of STCRs a change in direction was made towards the integration of STCRs to flow-line-like or production-line-

like systems, with stable processes and continuous material flow. The integration of multiple machine systems with other means of production necessitated the set-up of SEs on the construction sites SMART Prototype on Shimzu's research testing area in 1989. During the 1990s all major Japanese contractors and machine builders followed this approach and integrated their STCR technology together with other new technologies and approaches within Automated/Robotic On-site Factories. Individual companies in Europe and Korea followed.

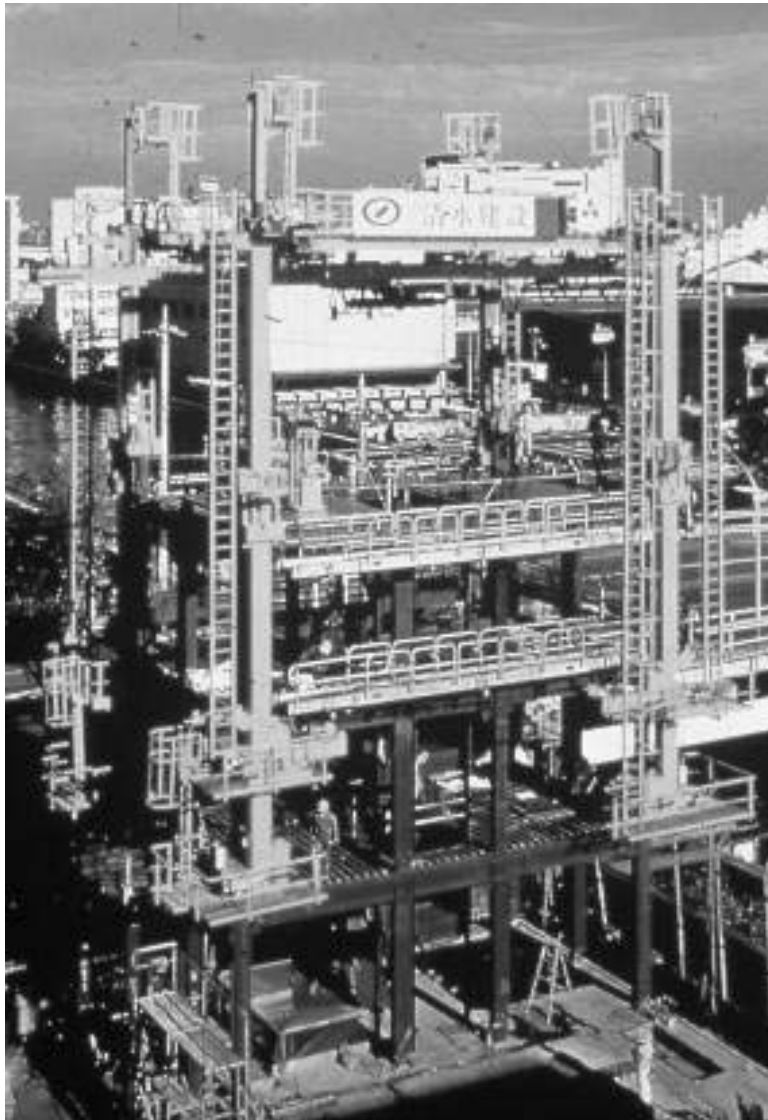

Figure 4-16: Test of fully functioning SMART Prototype on Shimzu's research testing area, 1988/89
(picture courtesy of **Bock**)

5 Integrated Automated/Robotic On-site Factories

In the following all worldwide conducted approaches following the above set direction to an on-site factory approach were analyzed. 30 different systems were identified, resulting in an application of Automated/Robotic On-site Factory technology about 60 times. The analysis was split into a more technical part and a part which focuses on parameters related productivity, efficiency and economic performance. All systems were analyzed systematically and based on the same frameworks. On basis of the analysis categorization system was developed and 13 categories were set up (ten categories for construction and three categories for deconstruction).

As discussed before (see 4), one of the main ideas for setting up automated on-site factories was to integrate stand alone or STCR technology into structured on-site environments to networked machine systems and thus to improve organization, integration and material flow on the construction site apart from the possibility to off-site manufacture components. Following the hypotheses set out in 1.6, the analysis intended to clarify for which building typologies Automated/Robotic On-site Factories are an applicable approach and how and to which extent those systems can be made technologically flexible in order to be able manufacture a variety of different buildings (products) on basis of industrialized, automated and flow-line like stable factory processes. Furthermore, it should be clarified whether, In contrast to the STCR approach (see chapter 4), the approach of setting up Automated/Robotic, On-site Factories is capable of achieving a performance multiplication (e.g. by the tenfold as in tunneling or automotive industry, see for further details 3.3, and 3.4 in particular) which usually accompanies the switch from arts and crafts based manufacturing to machine based manufacturing.

In this chapter, first, a framework for the technical analysis classifying into various analysis fields and analysis parameters is set up (see 5.1). Second, 30 systems are analyzed according to this framework and classified into two main categories (construction: 24, deconstruction: 6) and a total of 13 sub categories (see 5.2 and 5.3). Third, systems are analyzed concerning parameters that determine or influence productivity, efficiency and overall economic performance (see 5.4). An *Analysis and Categorization Matrix* gives an overview over systems, categories, analyzed parameters and available data. Finally the findings of chapter 5 are summarized (see 5.5). The conducted analysis claims to include **all** approaches to Automated/Robotic On-site Factories that were conducted so far.

5.1 Framework for technical Analysis

In this chapter, the technical aspects of integrated automated construction sites are analyzed. Automated construction sites represent ONM environments (fixed type or moving type) that conduct a final assembly of low, medium and high-level modular components rather than a conventional construction process. The installation of a factory on-site structures the work environment and allows the application of automation and robot technology. Furthermore, the processing of value-added components designed according to ROD strategies reduces on-site complexity. The modularization of both building products and manufacturing systems allows for a certain in-built or generable flexibility. The technical analysis follows the identification of concepts and strategies relevant to the fields of multilevel modularity (see 2.2) manufacturing technologies and strategies (see 2.1) and automation and robot technology (see 2.4). An overview of the framework developed for the technical analysis is presented in *Table 5-1*. Furthermore, on the following page, it is shown exemplarily (by Obayashi's Big Canopy system) that in the course of the analysis (for each of the 30 analysed systems) a detailed graphical representation was generated simplifying the comparison of strategies and on-site factory configurations.

The data used in this analysis were acquired from various sources as internal company project descriptions, publications by companies and their R&D staff, publications by researchers who had analyzed systems, by expert interviews with company staff and by site visits. Furthermore, as a basis for the analysis, documentary material in the form of plans, project descriptions and a picture archive documenting the application of nearly all systems were acquired. The analysis of the productivity and efficiency of integrated automated construction sites is presented in a separate section (see 5.4).

Table 5-1: Framework defining parameters for technical analysis of integrated Automated/Robotic On-site Factories

Field of analysis	Analysed parameters
Evolution Scheme	Location of SF and GF Working direction General workflow
Elevation	Detailed vertically organized workflow Parallel work on various levels Configuration of main and sub-factories Analysis of the component installation process
Ground Plan (Main and Sub-Factory)	Detailed horizontally organized workflow Configuration of main and sub-factories
Subsystems	SF (covered, working platforms, CSF, OSF) Vertical logistics (in particular VDSs) Horizontal logistics (in particular HDSs) Manipulators (in particular OMs) Climbing mechanisms (in particular CSs) Assembly simulation and progress control tools (RTMMSs and MHSPYs)
End-effectors	Types of end-effectors Relation of end-effectors and components/materials Modularity Possibility of tool changes
System Variations	Realised system variations Possible system variations Inbuilt flexibility Modular flexibility
ROD	ROD on a component level ROD on a building level ROD on an urban level

Sky Factory Structure

Horizontal Delivery System

System Variation 1

Climbing System

System Variation 2

Climbing Steel

Jib Crane (feeds Climbing System with Segments)

Vertical Delivery System

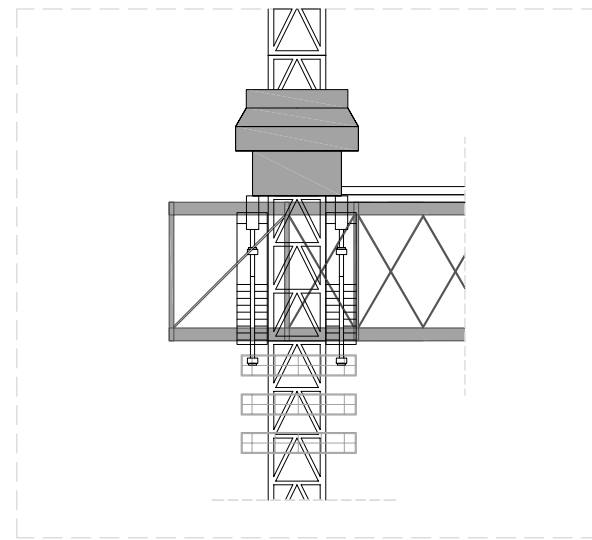
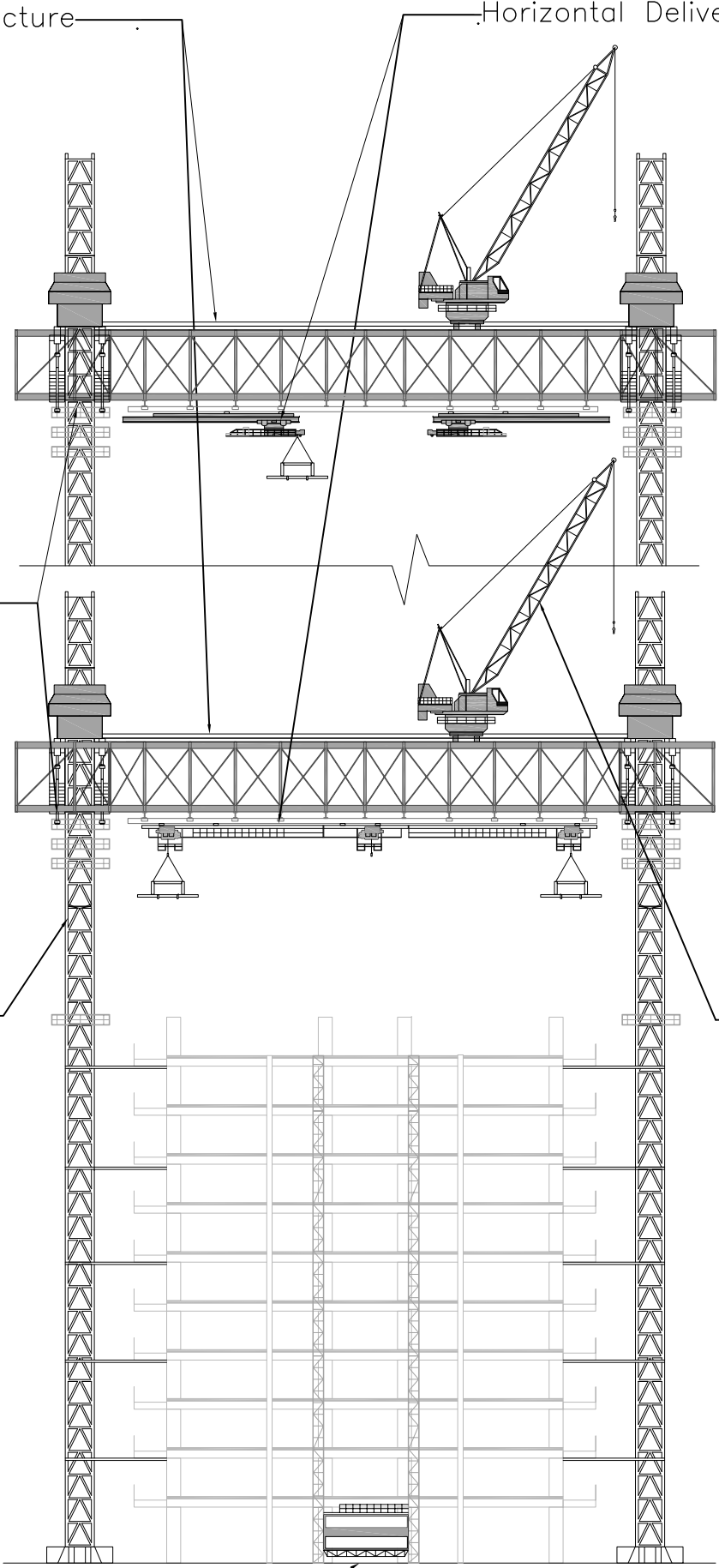

Climbing System

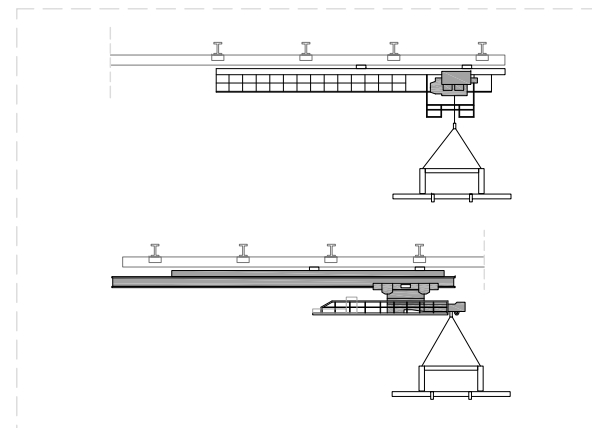

End-Effectors

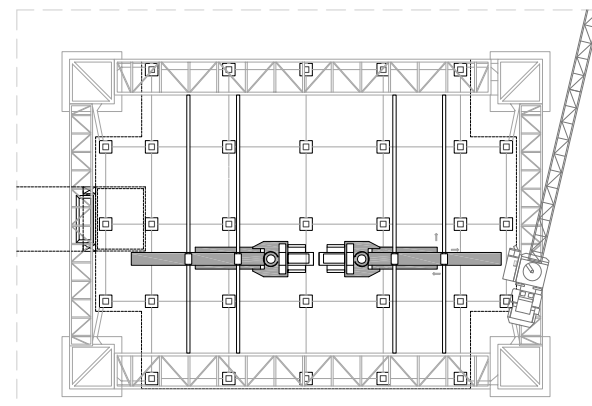

Sky Factory, Factory Layout System Variation 1

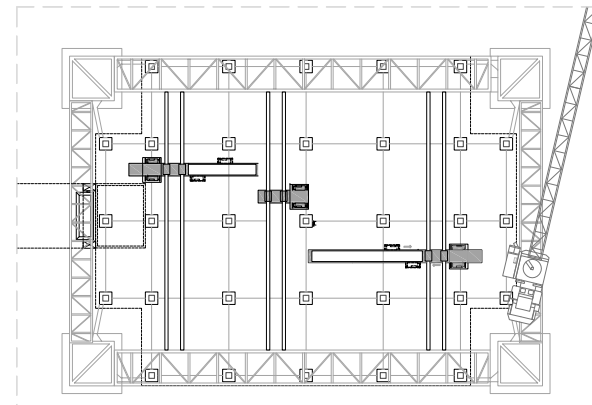

Sky Factory, Factory Layout System Variation 2

Big Canopy

Obayashi Corporation, Japan

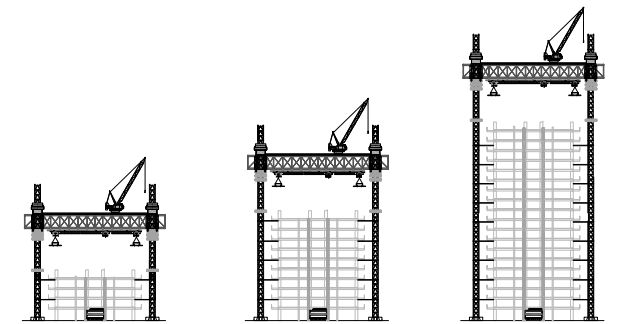

Evolution Scheme

5.2 Technical Analysis & Categorization: Construction

Integrated automated construction sites can be categorized according to various features or parameters, such as general working directions, logistics strategies, climbing mechanisms or configurations of the site-factories. It would also be possible to characterize according to manufacturing views (organisational view, product variation view, order oriented view, location oriented view; for further information, see **2.3**). Furthermore, a categorization according to the main building materials processed (steel based components, concrete based components) could be done. However, the general working direction and thus the location and orientation of the factory and the location of the majority of work activities play a major role in manufacturing and determine logistics strategies and factory configurations (see **2.3** and **2.4**). As buildings are products of complexity and size (similar to large aircrafts or tunnels; see **3.3.5**) that require a final assembly on the fixed and final site (see **3.3**), the orientation of the building and thus the location and working direction on-site determines the general organizational setting, and thus the logistics strategy, CS and factory configuration. In this thesis a combined location and working-direction oriented view forms the basis for categorization.

A location and working-direction oriented view on manufacturing considers the location or environment in which the product is manufactured as well as the geometrical characteristic of the product. Usually, a product can be manufactured off-site in a factory some distance from the final location to which the finished product is finally shipped and used, as the product in its final state is still a mobile entity for which a transport infrastructure exists. Most complex products, such as automobiles, aircrafts and consumer products can be produced that way. It is no problem to pack and ship them.

However products as buildings, towers, bridges etc. have to be produced on-site at the location at which they will finally be used and they clearly cannot be moved or shipped as an entity. High-level component manufacturers or unit manufacturers, such as Sekisui Heim circumvent the need for on-site production by splitting up a building into three-dimensional modules that are then produced and finished in the factory so that only minor work (in case of Sekisui Heim 15-20%; presented in detail in **3.2**) has to be done on the construction site. The automated construction system AMURAD, for example, follows a different strategy and produces the building by an automated/robotic assembly system on the final site and at a fixed place (ONM, fixed-site type; see also **2.3**) by using low to medium level precast and prefabricated components. Similarly, the erection of a tunnel by a Tunnel Boring Machine (TBM; see also **3.3.1**) with a mechanized or automated component/segment assembly system is an on-site production directly linked to OFM in the form of the delivery of prefabricated concrete segments. Unlike AMURAD, however, a “TBM factory” is moving and contains element of a production line on-site (moving type). The AMURAD system stays more or less at a fixed location (fixed-site type). In case of ABCS the factory moves upwards and, in case of Sommerfeld, it moves horizontally.

Civil engineering construction sites in tunneling are also called “line construction sites”. The strict organization along an axis or line simplifies systemic organization and (finally) permitted mechanization or automation by TBMs (see **3.3.1** and **3.3.6**). However, building construction and the erection of floor-by-floor along a direction which a building follows is more complex. Whereas a TBM can erect the main structure of a tunnel with one erector placing the segment, the erection of a main structure of a building or floor (columns, beams, floor slabs etc.) requires both a better integration of vertical (along the main direction) or horizontally (along the sub-direction) active positioning processes as well higher flexibility concerning kinematics and end-effectors due to higher components variability.

The categorization concerning the logistics strategy and the type of components processed by the on-site main factory was considered but not implemented. In addition to the main factory (e.g. SF), many companies deployed a sub-factory (e.g. on ground), where parts and components delivered to the site are stored (intermediate or buffer storage), assembled into more complex components, or prepared for lifting to and processing by the main (sky) factory (e.g. Akatuki 21). The advantage of this approach is that parts and lower level components can be transported to the site more efficiently than complex components. Although the logistics strategy, in terms of efficiency of the systems, might be a key element, it was not be considered as a basis for the categorization, as this strategy can basically be applied to any automated construction site and thus is not a unique characteristic. However, whenever companies have used sub-factories it has been worked out in the analysis.

The analysis showed that some deconstruction systems working with downwards moving SFs also utilized the ground floors of a building as a sub-factory/GF where high-level components coming from the SF were processed into low-level components or mono-material for direct transport to the recycling facility. ONM systems share a need to be highly mobile, easy to deploy and dismountable as they are only temporarily installed. For example, Shimzu has developed a simulator for the SMART for optimizing the installation and the disassembly of the factory on a specific site and for a specific building. Compared to OFM systems, so far ONM systems tend to have a lower efficiency and lower degrees of automation (see also **5.4** and **5.5**). A reason for that is that complex automation and robot systems need a relatively long time to be set up and require a high degree of precision. However, current trends in automation and robot technology, such as modularity, plug-and-play and lightweight design, lower the barrier to entry (for further discussion of the capability of automation and robot technology, see **2.4**).

Some companies also have tried to avoid the necessity for disassembly of the factory (e.g. Obayashi, ABCS) by integrating the frame of the factory as a frame for the final floors into the building after completion. Taisei’s deconstruction system tries to avoid both the assembly and the disassembly of the on-site factory by utilizing one of the top floors as a roof and the basis for the installation of OMs.

5.2.1 Sky Factory (moving upwards) – supported by building

Systems in this category are based on the erection of a sky-factory on top of the building to be constructed. The buildings are assembled from bottom to top. In the SF each floor is assembled in turn and the newly constructed floors are used as the supporting structure that the climbing mechanism of SF uses to raise the factory upwards.

Three types of climbing mechanisms can be identified:

1. The factory climbs using stilts which use the vertical column structure as support (ABCS, Akatuki 21, FACES, MCCS, Roof Push-Up, Roof-Robo)
2. The stilts carrying the factory are supported not by resting on top of individual columns but by using a bridging system and fixing them in between columns and on beams connecting the columns (SMART).
3. The factory rests on the building through girder framework bridges (System Netherlands)

Climbing mechanisms type 2 and type 3 have the advantage that the positioning and fixation of columns on top of other columns is not hindered by the climbing mechanism. However, climbing mechanism type 1 can be used as a fixture of a jig (see **2.4**), which helps to guide the column into place. Some systems are based on the idea of using a GF (assembly of low-level components to medium or high-level components, Akatuki 21, Roof-Robo) and others focus more on the direct pick-up of components from trucks. However, a lot was experimented from application to application, and basically all systems in this category have the potential of using GF, direct pick-up or a combination of both approaches. Systems in this category also vary considerably concerning the type of manipulators (automatic/robotic crane systems) used.

While some companies build on a reduced number of high-capacity, large and heavy (but highly accurate) manipulators (e.g. FACES), others follow the strategy of distributing complexity and build on a multitude of smaller and faster manipulators that can be operated in parallel (e.g. SMART). A further characteristic of systems in this category is that the SFs completely seal the working environment from the outside and create weather protected and soundproof environments. Accordingly, most systems in this category organize much of the vertical logistics within the building itself, using stair cases or elevator shafts as logistics channels, for example. Thus, GF work, vertical logistics and work in the SF is not affected by the weather. Furthermore, SFs encompass the building completely and also provide working platforms on the outside of the facade which allows the finishing and sealing of the facade within the factory and the floor finishing cycles (for further information on floor finishing cycles, see also **5.4**)

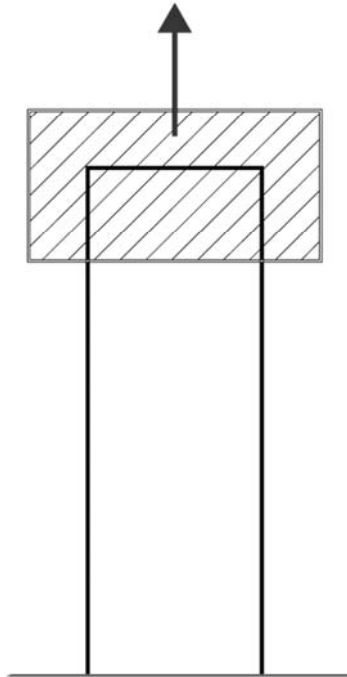

	System Name	Company
1	Automated Building Construction System (ABCS)	Obayashi
2	Akatuki 21	Fujita
3	Future Automated Construction Efficient System (FACES)	Goyo/Penta Ocean
4	Mast Climbing Construction System (MCCS)	Maeda
5	Roof Push-up	Takenaka
6	Roof-Robo	Toda
7	Shimizu Manufacturing System by Advanced Robot Technology (SMART)	Shimizu
8	System Netherlands	BAM

Automated Building Construction System (ABCS)

Company: Obayashi Corporation, Japan

Category: SF (moving upwards) - supported by building



ABCS SF automatically constructing a high-rise building floor-by-floor

Evolution Scheme: ABCS concentrates work activity on a main factory which covers the top 4-6 floors to create a structured work environment. Within this work environment the steel main structure is erected, the facade is installed and sealed and the interior is completely finished, so that when the factory moves upwards a completely finished building (or floor as the factory moves floor-by-floor) is left below. Usually, the factory is installed on top of the first two or three floors and starts operation from these floors onwards. The installation of the site factory at the beginning is time consuming (3-6 weeks), however during full operation and after the learning phase, the system can fully complete up to two floors per week. In order to simplify the disassembly of the site factory, the steel frame structure of the factory is, in some projects, integrated as the load-bearing structure of the top floors of the building being manufactured.

Elevation: The components are delivered to the factory by VDSs (automated lifts). In the factory, the components are picked up from the lift in a JIT and JIS manner by other horizontally operating subsystems. Depending on the required capacity, the number of vertical lifts can be varied. In most cases so far, more than one lift has been installed in order to allow for a continuous vertical material supply (while one lift was going down to pick up the next component the other lift had already delivered the next one). The automated vertical lifts could be positioned either on the outside of the building (longitudinal side) or within the floor area in shafts which can be closed after building completion or used, for example, as elevator shafts. ABCS does not explicitly install a GF, but uses the ground floors for storage, delivery and sequencing purposes.

Ground Plan: The horizontal delivery and positioning of components is done by vertical gantry and overhead type manipulators (guided by a fixed rail system mounted to the roof structure of the factory) which can exchange their end-effectors. The manipulators can be used for picking up components from the VDS and directly installing them or only for vertical transport and handing over to other manipulators. The installation of facade elements can be done either by the horizontally operating manipulator (in conjunction with a dedicated end-effector) or directly by an additional (and optional) VDS which is only used to deliver and install facade elements directly.

Subsystems: The ABCS manufacturing the building on-site (system) consists of a multitude of integrated subsystems:

1. **Factory Roof Structure:** Covers the workplace completely, covers the vertical logistics system, provides structure for mounting of rail system for operation of horizontal manipulators, provides covered and safe working platforms for facade work.
2. **CS:** The factory rests and ascends atop of steel columns positioned, aligned and fixed to hydraulically powered steels which bear the weight of the roof structure and push it upwards floor-by-floor. Stilts are positioned over each column; only every second of the stilts is needed to bear the factory, thus it is possible for every second stilts to be lifted to enable the positioning of a new column by the manipulator under it. The CS is not

used as a physically active fixture, allowing the self-adjustment of the component (as with FACES) to at least guide the installation process by providing reference points for the AAMS.

3. **VDS:** automatic lifts of different capacities that deliver material up from the ground to the SF. The lifts can be extended with the upwards moving SFs simply by placing new lift elements on top of the lift system.
4. **HDS:** gantry type OMs with exchangeable end-effectors. Manipulators are rail-guided – the gantry system is able to move (parallel translation) along two rails lengthwise, to move perpendicularly, to rotate and to lower components. With these 4 DOFs the manipulators are able to reach any point within the working space. In cooperation with the end-effectors additional DOFs are gained. Within each lengthwise rail system one manipulator moves. Depending on the width of the building, 1-3 rail systems (and thus manipulators) can be installed side by side.
5. **Facade Element Delivery and Installation System (optional):** Under the factory roof, along the facade (outside of the floor area but along the building facade/edges), an additional rail-guided delivery system can be installed which vertically delivers and vertically/horizontally positions and adjusts facade elements. The system disburdens the vertical and HDSs mentioned above and allows for further parallelization of manufacturing processes.
6. **Welding Robot System for Columns:** The welding robot systems for columns are mobile STCRs which have been made a part of the integrated site operation. The mobile system is moved on top of the already completed floors to the column positioned and aligned by the manipulator and then to the column to be fixed by welding. The robot embraces the column and welds it from two sides simultaneously, so that any distortion of the steel column by the welding process is avoided. Several welding robot systems can be used to weld more than one column in parallel.
7. **Welding Robot System for Beams:** The welding robot system for beams is positioned by the manipulator on top of preliminary fixed beams to weld/fix the beam components to the column components. The welding system consists of two frames used for the attachment to the beams and four welding robots, with one welding head each, mounted on top of these frames.
8. **Mobile (horizontal/floor-by-floor operating) Logistics Robots:** On floors within the SF which are already covered with ceiling elements, and which are thus no longer accessible by the OMs, mobile logistics robots are used for horizontal material delivery (mainly for delivering material for interior finishing). The logistics robots are integrated into the management and real time control system and can communicate with the automatic vertical lifts in order to achieve “just-in-time, JIS material delivery”.
9. **AAMS:** Sets of optical sensor systems (stereo vision systems, 1-D and 2-D laser scanning systems) are used to support the alignment and accuracy measurement.

10. **RTMMS:** Data from sensor systems as well as from the servomotors/encoders of the V/HDS along with information obtained from cameras monitoring all activities (including human activities) in the factory are used to create a real-time representation of equipment activity and construction progress. A barcode system allows representing and optimizing the material flow and allows equipment (such as the automatic lift) to identify the component being processed. Real-time monitoring and management is done in a fully computerized on-site control center.

End-effectors: The manipulators (HDS) can be equipped with various end-effectors suiting the pickup, positioning and adjusting of various component types:

1. End-effector for pickup, positioning and adjusting of columns
2. End-effector for the horizontal delivery of multiple beams or steel profiles
3. End-effector for the positioning of beam/girder elements
4. End-effector for pickup and positioning of concrete floor slabs
5. End-effector for delivery positioning of welding robot system for beams.
6. End-effector for positioning of prefabricated large scale facade elements

System Variations: The SF consists of a modular steel frame system which can be adjusted to buildings with varying length and width. Depending on the width of the building, 1-3 rail systems (and thus manipulators/HDSs) can be installed side by side. With the rising amount of HDSs, multiple vertical lifts can be installed inside floor area or along the facade. So far only rectangular buildings have been manufactured with ABCS. The end-effectors have an in-built flexibility which allows them to pick up components of the same type with varying diameters or dimensions. The possibility of exchanging end-effectors allows completely new and initially unforeseen types of components to later be used. During the application of ABCS in various projects, Obayashi experimented with different automation ratios (see also 5.4, efficiency analysis).

ROD: The system's vertical and horizontal manipulators process mainly prefabricated low-level components (steel columns, steel beams, concrete floor slabs) and high-level components (facade elements completely equipped e.g. with windows). All components are pre-adjusted to fit into the manipulators' working space and DOFs, and to the end-effector range/inbuilt-flexibility. The alignment of steel columns, steel beams, and concrete floor slabs is guided by compliant joining systems, and the installation of facade components by compliant and plug-and-play joints, reducing the need for human workers to guide or assist the installation process.

Akatuki 21

Company: Fujita Corporation, Japan

Category: SF (moving upwards) supported by building

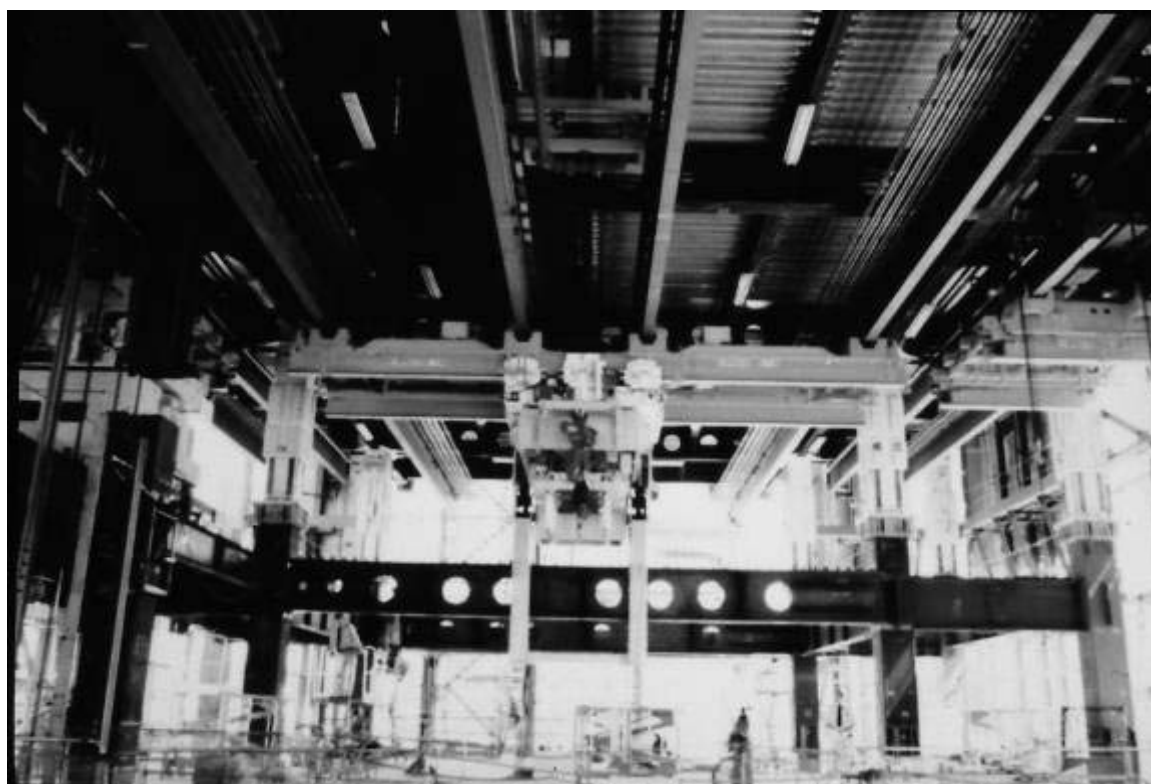

SF interior view/OM

Evolution Scheme: Akatuki 21 distributes work activity over a GF and an SF. In the GF, material is stored, processed (e.g. parts for components), and prepared for the final installation process in the main factory. The GF reduces complexity (amount of assembly steps, necessarily complex kinematics). The main factory is the focal point of the assembly of the building. It provides an enclosed and SE for the installation of components by rail-guided gantry type OMs. The SF operates on a floor finishing cycle of 6-7 days. On the main operation level, the installation of beams, installation of steel profiles and concrete floor slabs, distribution of and levelling of concrete is all done or supported by the OMs. On the floors below this level, interior finishing is done in parallel.

Elevation: The analysis shows the concentration of equipment within the GF and SF. Various VDSs connect the two factories, building up a continuous material flow between both. One large automatic lift (located centrally within the floor area) supplies all manner of parts and components. Another lift directly supplies beam elements prepared on the ground floor to a manipulator equipped with an end-effector for beam handling. During delivery, the beam element is brought by the lift from a horizontal position into a vertical position. A further delivery system, in the form of a winch system mounted under the overhanging roof of the SF, is used to lift material directly up to the SF. A jib crane on top of the building further supports vertical logistics and is used to assembly, maintain and disassemble the SF.

Ground Plan: In the GF, both rail-guided AGVs and gantry type OMs are used to transport components from stockyard or MHSPY to the various VDSs. In the GF materials are unloaded from incoming trucks and are quickly transferred, for example via the rail-guided AGVs (if necessary JIT, JIS) to the vertical conveyor system or the MHSPY. The GF installs MHSPY where, for example, the beam components are prepared for the direct and uninterrupted installation in the SF by a manipulator. In the SF, depending on the configuration of the building, 1-2 rail systems are installed in a longitudinal direction. Then along this rail system, the manipulators can move, pick up components from the VDSs and position and adjust them.

Subsystems: Akatuki 21 manufactures the building on-site (system) by ground and main SF consists of a multitude of integrated subsystems:

1. **GF Delivery Yard:** Trucks deliver incoming materials to an enclosed factory part erected on a ground level and attached from the outside to the building. Overhead cranes assist in unloading material to AGVs and precast concrete panels conveyance flat car.
2. **GF Parts/Components Stock Yard:** Enclosed factory part erected on ground level and attached from the outside to the building. Used for warehousing.
3. **GF Parts/Components MHSPY:** Enclosed factory part erected on ground level and attached from the outside to the building used for preparing components for delivery

and SF installation process. Parts and lower level components are transformed into higher level components.

4. **GF HDS:** AGVs (including as conveyance flat car for precast concrete panels) transport material between the different GF yards, and from yards to the input slots of the VDS.
5. **VDS 1 (automatic lift):** an automatic lift works in a shaft within the floor area to deliver all types of parts and components to the floor where the manipulators operate. The automatic lift goes below ground, so that placing of components in it is easily possible from the ground.
6. **VDS 2 (column lift):** An automatic lift takes up columns vertically in the GF (parts/components processing yard) in horizontal position and delivers them on a shuttle to the SF in vertical position. The horizontal position on ground level simplifies delivery and preparation, the vertical position in SF simplifies the pick-up and installation process.
7. **VDS 3:** Vertical Exterior Lift. Upon their delivery, the lift eases the installation of exterior works such as facades into the right position. Thus the size of the SF can be reduced.
8. **SF Structure:** The SF uses the ceiling of one of the top floors as a roof which encloses the building and to which the rail systems guiding the manipulators are mounted. Up to two top floors are conventionally constructed on the ground and are pushed up as the SF rises, finally becoming part of the building.
9. **CS:** The SF (or rather the two top floors) are supported and lifted hydraulically by stilts which rest directly on the erected columns. The steels are lifted one by one in order to place new columns under it. Once all columns have been placed, the factory is pushed up.
10. **SF HDS:** gantry type OMs with exchangeable end-effectors. Manipulators are rail-guided – the gantry system is able to move backwards and forwards along two rails, to move sideways, and to lower components. With these 3 DOFs the manipulators are able to reach any point within the working space. In cooperation with the end-effectors, additional DOFs are achieved. One manipulator operates within each of these rail systems. Depending on the width of the building 1-2 rail systems (and thus manipulators) can be installed side by side. The horizontal SF delivery system is directly integrated with the VDSs so that JIT, JIS delivery and installation chains are possible.
11. **Welding Robot System for Columns:** The welding robot systems for columns are mobile STCRs which have been brought into the integrated site operation. The mobile system is moved on top of the already completed floors to the column positioned and aligned by the manipulator and then to the column to be fixed by welding. The robot embraces the column and welds it simultaneously from two sides so that any distortion of the steel column by the welding process is avoided. Several welding robot systems can be used to weld columns in parallel. As a series of operations, (ex. sensing of

beveling, removing of slug to nozzle cleaning) can be performed automatically, continuous multi-layer automated welding becomes possible.

12. **RTMMS:** Fujita used a control room equipped with more than 20 monitors to supervise work tasks and the operation of the equipment of Akatuki 21. Furthermore, the progress of the construction and the quality of the constructed floors was monitored. The control room required 1-2 supervisors (see also 5.4, efficiency analysis).

End-effectors: The manipulators (HDS) can be equipped with various end-effectors to suit the pick-up, positioning and adjusting of various component types:

1. End-effector for pick-up, positioning and adjusting of columns
2. End-effector for the positioning of beam/girder elements
3. End-effector for concrete placing and concrete levelling
4. End-effector for positioning of prefabricated large scale facade elements

System Variations: Within the rectangular shape and orthogonal organization of the building and the components from which it is put together, buildings can vary in width, length and also to a certain extent in the underlying grid structures. The modularity of the end-effector systems allows new component types to be added and efficiently handled by co-adjusted end-effectors without the need for major changes to the manipulators or other subsystems.

ROD: Akatuki 21 follows the principle of ROD on a component level i.e. by the design of the column elements which allow for fast assembly as well as for an efficient vertical and horizontal delivery. On a building level the efficiency can, for example, be enhanced by designing buildings which are longer than they are broad in order to exploit the capacity of longitudinal rail-guided rail-manipulators. On a city level, the optimal functioning of the GF (interplay of storage yard and MHSPY elements) can be supported by the appropriate

Future Automated Construction Efficient System (FACES)

Company: Goyo/Penta Ocean, Japan

Category: SF (moving upwards) supported by building



SF

Evolution Scheme: FACES concentrates work activity in an SF. The SF and the subsystems operating in it are assembled on the ground level. The SF, due to its physical configuration, starts operating on the 3rd floor. Basement work and the erection of the 1st and 2nd floors can be done in parallel to the SF set-up. The SF is composed of roof frame, support frames, side shelters, and all subsystems are physically and informational connected under its umbrella. In the uppermost floor, under the SF, manipulators assemble the main structure (columns, beams, floors). In the 3 floors under this operational floor, fixation and welding is done, facade elements are assembled and interior finishing is done in parallel. Central to the system are the two shuttle cranes (manipulators) accomplishing the vertical/horizontal distribution, positioning and adjusting of low and high-level components, such as steel column and beam structures, and the facade elements.

Elevation: The FACES SF completely covers the workspace and provides a SE for the main structure erection, facade work, fixation and welding, and interior work. In total, 4 floors are considered to be part of the SF: the n th (uppermost) floor, $n-1$ floor (welding of girders and columns, concrete slab placement), $n-2$ and $n-3$ floor (e.g. interior work, external sealing). The lead times per floor and the detailed work activity schedule is analyzed in detail in **5.4 (efficiency analysis)**. Once the construction of a floor is completed, the system is pushed up by means of 250-ton oil-hydraulic actuators supported by about one-third of the building's columns (depending on the configuration of the building) at a rate of 2mm/sec, i.e. approximately one floor per hour. This process is repeated floor-by-floor until the whole structure has been completed and the temporary shelter at the top has been disassembled

Ground Plan: The analysis of the ground plan reveals that the two high-capacity OMs (also called shuttle cranes) operating the length of the factory play a central role. Each manipulator operates in a fixed trajectory along two rail profiles mounted to the supporting roof frame of the SF. In order to transfer units from the ground yard to the target position, the system has two material intake ports: the main intake port and sub intake port. To raise the SF, the CS pushes it up on steel frames (in this case a steel truss embracing a column) resting on top of the columns installed by the manipulators beforehand. The CS is positioned only over certain column rows (e.g. every second) and functions also as a fixture which guides columns to their position, and which ensures the precise assembly of other columns by giving reference points.

Subsystems: FACES, manufacturing the building on-site by way of an SF consists of many integrated subsystems:

1. **MHSPY (optional):** 50t truck crane for material handling on the ground in the MHSPY.
2. **VDS (optional):** Temporary lifts in the construction factory: one with a capacity of 2.8t and of 0.9t.
3. **SF Structure:** The SF encloses the workspace on the n th to $n-3$ floors completely, ensuring a weather-protected, structured work space. It also is a carrying frame which holds the OMs and provides incoming ports for lifted up material and components. The

SF also provides working platforms for outside facade work. When the construction work is taking place on the n th floor, the wall installation task is carried out on $n-3$ Floor. In order to position the exterior walls and other wall details, additional manual support is needed, for which exterior scaffolding by the side shelter is used. Exterior sealing work can be finished as soon as the wall components have been installed. As a safety precaution, a protective sheet is installed to protect against sparks and falling objects.

4. **CS:** The CSs consist of a steel truss, which embraces the column and which supports the SF. An inchworm-like pushing mechanism operates in each steel truss. The lower end is fixed to the column and functions as fixed point for the pushing up of the steel truss (and thus the SF). The operational sequence is thus:

- The frame is lifted up by pushing against the building column located just beneath the lower clamp.
- The supporting columns on the new floor are prepared.
- The oil hydraulic cylinders rest on the newly erected supporting columns.
- The base supports are opened.
- The lower clamps are locked and the upper clamps are released.
- The lifting of the system continues like the movement of a worm.
- After the completion of the lifting procedure, the base supporters are closed again.
- Slight lowering.
- The procedure is repeated until the building reaches its target height.

The CS functions also as a fixture/jig: A jig guides the columns into place and, by the giving of reference points, ensures the precise assembly of other columns.

5. **SF HDS:** Gantry type OMs (also called shuttle cranes) with exchangeable end-effectors. The manipulators are rail-guided; the gantry system is able to move along two rails lengthwise, to rotate, to translate (extend main link), to rotate the last link and to lower components along the axis of translation of the last link (5 DOFs). End-effectors which do not add additional DOFs are exchangeable and take over component-adjusted grasping/releasing functions. Each of the two manipulators has an adjustable working radius (over the main link, which is extendable) of 6m to 10m. As the workspace of the two manipulators overlaps in certain positions and working modes, an avoidance system prevents collisions. The two heavy but high capacity manipulators are central to the assembly process. Unlike in other systems, the two manipulators have a high payload capacity, integrate a multitude of DOFs, have a relatively big working space and guarantee high precision. Furthermore, the manipulators can also function as a VDS, lifting up components from the ground (via the two material delivery ports) and thus eliminate the need for the handover of components from the vertical to HDS. A disadvantage is their low speed (in lifting up as well as travelling along the overhead rails), also discussed in 5.4 (efficiency analysis). Each manipulator has a lifting load capacity of 10 tons. The kinematic structure of the manipulator is as follows:

- Five DOFs

- Two rotational turning mechanisms: hook turning ring & boom turning frame.
 - Three prismatic movements: along traveling rails; shuttle
 - Stretch, and hook roll up & down
 - Each manipulator has a lifting load capacity of 10 tons
6. **Welding robot system for columns:** Articulated, 5-axis computer-controlled, automatic welding robots connect two steel columns vertically. The robots travel along guiding rails temporarily fixed to the column. By precisely welding from opposite sites they improve welding quality and consistency by eliminating a strenuous and unpleasant phase of construction.
7. **RTMMS:** A site office controls the SF and MHSPY via work plans and quality control; real-time monitoring and evaluation of site progress; finishing and working floor supervision; analysis of the structure; safety instructions; material handling and traveling inspections; management of workers' input and output; and via a real-time virtual-reality display of each manipulator's operation.

End-effectors: The manipulators (HDS) can be equipped with various end-effectors to suit the picking up, positioning and adjusting of various component types:

1. End-effector for picking up, positioning and adjusting of columns
2. End-effector for the transporting and positioning of multiple beam/girder elements. As the manipulators operate relative slowly in one operational sequence, up to three beams can be installed: 2 - 3 beams / Capacity: 6tons / Beam size: 200-900 x 150-300mm. The time required is thus reduced by approximately 40% compared to single beam transport.
3. End-effector for the positioning of other non-standardized parts and components
4. End-effector for curtain wall element installation
5. End-effector for exterior (concrete) wall element installation
6. End-effector for interior wall element installation

System Variations: The system can be varied on a rectangular grid system in a lengthwise direction on the basis of a synchronized column/CS grid. The variation in the sideways direction is also possible considering that the manipulators main link can regulate translation within a margin of 4 meter, and that less overlapping of workspace means less manipulator capacity in each workspace.

ROD: On a component level, the design of the components (size, dimensions, and load) is synchronized with the manipulators workspace and kinematic capability, as well as with the end-effectors. A temporary alignment system (four small steel plates on each of the four column sides) is welded to each column to allow the columns to be guided into place. The steel pieces are later removed after the positioning and adjustment operations (before the welding of the column onto which it was placed). On a building level, the length and width of the building are adjusted to the system, considering that the main manipulators operate relatively slowly lengthwise. This means that overly long buildings are disadvantageous, or

might necessitate additional manipulators. On the other hand, buildings which are not long enough will not take full advantage of the capacity of a single manipulator. Furthermore, the structure of the building should take into account the need to synchronize the column grid with the factory structure's grid system in order to be able to allocate the climbing mechanism. Finally, the degree to which (if at all) the two manipulators and their working space overlap has to be taken into account. On a city level, the design of the building and its surroundings should take into account that incoming material is delivered to the SF via lifting ports.

Mast Climbing Construction System (MCCS)

Company: Maeda Corporation, Japan

Category: SF (moving upwards) supported by building



SF

Evolution Scheme: The MCCS uses the steel framework of the uppermost floor of the building that is to be erected as the roof structure for the SF, to which other subsystems (e.g. manipulators) are mounted. The roof structure is, therefore, firstly built on the ground and then lifted by means of steel stilts belonging to the climbing mechanism. The first 1-2 floors under the roof are partly conventionally built, but are already supported by the system. Full operation of the MCCS starts from the 1st or 2nd floor and up. After the assembly and running process is finished, the factory on the climbing floor needs to be dismantled. This process requires two JCC 105 cranes to be brought up to the uppermost part of the building using the active cranes. Once they have been placed and assembled, they start lowering down the materials from the SF that will not remain as a part of the building.

Elevation: In the SF, two rails guide OMs with partly overlapping workspace positions and align the load-bearing main structure of the building (column components beam components) as well as large scale facade panels. The supply of material is accomplished via an automatic material lift running up a shaft within the floor area, which delivers material at the intersection area between the workspaces of the two manipulators. Additionally, each manipulator has a gate in the side of the SF through which it can reach out and lift components up directly from ground. Work takes place over three floors simultaneously (uppermost floor: installation of column and beam elements; $n-1$: installation of facade elements, plus interior work; $n-2$: sealing of facade from the outside by the platform provided by the SF, plus interior work).

Ground Plan: The ground plan shows the grid system on which the columns are installed by the manipulators. The SF rests on steel stilts which sit on top of the outer row of columns on the two face sides of the building. For the positioning of columns under the stilts, the stilts have to be lifted (one after another).

Subsystems: The MCCS consists of many integrated subsystems:

1. **VDS (Automatic Lift):** Operating in a shaft within the floor area. Positioned so that both manipulators in the area of their overlapping workspace have access to it. Mainly used for the vertical transportation of finishing material to the SF. An electronic gate on the ground floor can read barcodes (and thus identify the components) and provide the manipulators with necessary information about the installation process.
2. **SF Structure:** The carrying roof frame of the SF is later used as the uppermost floor of the building. It is initially built on the ground then lifted up; the manipulators, side covers, working platforms etc. are then installed to it. The SF completely covers the building and provides a weatherproofed, SE. The factory has two incoming ports (one for each manipulator) located on a side of the building. The ports can be opened automatically if the manipulators need to reach out to lift up components. The control room is also located in the load-bearing roof structure.

3. **CS and Column Catchers:** The SF roof structure is supported by steel stilts which rest on the (already installed) outer columns of the building. For the lifting process, climbing robots are attached to each stilt in the roof structure of the SF. Each robot has two oil jacks and two lock pins at the top and the bottom. These locks are inserted into the holes of the stilts. Once the climbing robots are secured, a computer simultaneously controls all of the jacks on the stilts to extend or shrink them, in order to provide inchworm-like movement. Once the climbing floor has been lifted, the computer re-secures the lock pins to stabilize and provide the necessary safety. Two jacks are placed on each stilt. The climbing device is in charge of lifting up/down the climbing floor, utilizing a synchronizing jack cylinder and a lock cylinder for stability. At the bottom of each stilt an automatic 'column catcher' is installed. This is a hydraulic device for temporary combining the stilt and the column (which is directly below the mast) of the building.
4. **SF HDS:** The manipulators (also referred to as active cranes within the MCCS) are the central subsystem of the MCCS. The active crane is positioned in the horizontal trolley, which allows the active crane to move from left to right. This trolley then moves itself vertically (guided by overhead rails mounted to the roof structure of the factory) via another trolley, allowing the active crane to increase its working space. Each of the two manipulators has 5 DOFs: translation by trolley lengthwise, translation by sub-trolley right/left, turning of main link, extension of main link along the axis, and lifting/lowering of end link).The manipulators' main rails are installed side by side so that their working spaces overlap.
5. **Factory Disassembly System:** The factory and subsystems on the climbing floor need to be dismantled. For this process two JCC 105 cranes are lifted up by the manipulators to the operational floor. They are then installed on the roof structure of the factory so that they can start disassembly of the factory.
6. **Welding Robot System for Columns:** Two sets of robots (a total of 4 robots). Each set comprises two robots traveling on a steel ring encircling the columns. The columns are perfectly aligned by the measuring and alignment subsystem (see below), and the computer-controlled welding (from opposite sides) ensures that this alignment is not disturbed.
7. **AAMS:** in the MCCS, the alignment and displacement of each column installed by the manipulators is measured by 1-D laser systems (horizontally and vertical displacement) and reflector sheets installed on top of each column. At the bottom of each column waiting to be aligned, an alignment jig device is installed to accomplish the final alignment.
8. **RTMMS:** The MCCS has a control room at the top of the climbing floor, in which the activities of the active crane, robots, and lift and measuring system are monitored and controlled. All in all the MCCS integrates the following management and real-time control capabilities:

- *Machine Running Management System*: This system displays the status of climbing devices and active cranes, as well as wind direction, wind velocity and temperature in and around the factory
- *Progress Management System*. This system displays 3-D information on the materials being transferred by the active crane. This data is entered into the computer and filed into a disk.

End-effectors: Compared to other systems, the manipulators are equipped with relatively simple (hook) end-effectors. However, systems such as the alignment jig can also be seen as end-effectors supporting the installation process. Additionally, the column can also be seen as end-effectors.

System Variations: The system can be varied in length and width on the basis of a grid system that synchronizes building systems and manufacturing systems. As the steel stilts holding the SF rest on the outer rows of columns of the two front sides, and the factory roof structure spans the building without additional support, the distance allowed between the two face sides is limited and allows only for minor changes. However, several grid fields can be simply added to the two rail systems guiding the manipulators.

ROD: On a component level, the column components in particular, as well as the facade elements, are designed according to ROD principles. However, compared to other systems, no compliant joints or plug and play joints are used. On the contrary, devices such as the alignment jig (in combination with the alignment measuring system) or the column catcher are used, so that no major resign of the building component joints is necessary. On a building level, the structure of the SF and the building's columns grid has to be adjusted to each other. From an urban point of view, the location of the side gates through which the two manipulators reach out and directly lift components can be considered in terms of ROD (e.g. it would be advantageous if the orientation of the building allowed trucks to easily access this side of the building during the construction time).

Roof Push-up Construction Method

Company: Takenaka Corporation, Japan

Category: SF (moving upwards) supported by building



SF

Evolution Scheme: The Roof Push-up system concentrates manufacturing activity in an SF where low and high-level components such as steel columns, steel beams, floor elements, plumbing and plumbing units are installed in a weatherproof and SE. At first, on the ground, cranes and material lifting facilities are installed. The factory itself is then set up at a ground level (by use of the jib crane). Then, step-by-step, one floor after the other is constructed inside the SF. Stilts, which are part of a CS, rest the SF on top of columns erected and complete the climbing.

Elevation: Special features of the system are the integrated jib crane on top of the system, which is used to lift up and position prefabricated plumbing components and units as well as by providing a method/equipment which allows the convenient overhead installation of plumbing and overhead interior finishing. Furthermore, as in most other systems, the installation of components of the load-bearing structure is done by rail-guided OMs. An automatic lift over a shaft within the floor area delivers material to the SF. A weatherproof steel structure surrounds the floor being constructed. This surrounding extends from roof to the two floors below the roof. Thus the structural construction of the intended floor (n) is completed at the same time as the installation of facades and additional room facilities on the floor below the n th floor.

Ground Plan: Materials from the ground floor are taken by a lift and then delivered to the n th floor. The materials are taken and delivered to the desired position within the n th floor by the overhead crane. The overhead cranes can move horizontally and can be controlled manually. On the construction floor, two overhead cranes work on the movement of the columns and other steel frames. The roof is raised by raising the SF's steel stilts and placing new columns under them. When the stilts supporting the roof are raised, the gap is filled by a temporary column until the new column is positioned, aligned and fixed.

Subsystems: AN SF's Roof Push-up Construction Method (system) consists of a multitude of integrated subsystems:

1. **VDS (automatic lift):** an automatic lift running in a shaft within the floor delivers parts and components into the SF. After completion, the shaft can be closed or used as a vertical shaft for staircases or elevators.
2. **SF Structure:** the SF structure covers the building and provides a weatherproof and SE. It integrates the jib crane on top, the manipulators, the lifting mechanism, the mechanism for lifting floor elements after overhead work (overhead interior finishing system) and working platforms for exterior facade work. The roof structure of the factory after completion is integrated into the building as the roof or at least as one of the uppermost floors.
3. **CS:** Hydraulic jacks are used to lift up the floor step by step. The jacking work is carried out in several steps. Firstly, climbing stilts supporting the SF structure are lifted up by hydraulic jacks. Secondly, a temporary column is installed and the structural building columns are positioned, aligned and adjusted. Thirdly, the stilts supporting the SF are

lowered again and fixed onto the installed column and the temporary column is removed. This is done for each column on the floor. Finally, the factory can be raised.

4. **SF HDS:** Two lengthwise rail-guided OMs (predominately remote controlled) position components delivered into the factory by the automatic lift. The working space of the two OMs overlaps in the area of the central row of columns. Each manipulator has 5 DOFs (starting from base point: translation lengthwise, translation right/left, rotation parallel to floor level, rotation perpendicular to floor level, traveling of hoist along final link axis). Each manipulator's final link consists of two forks which can embrace the lifted climbing stilt and position column elements under it through the traveling of hoists (holding the column) along the two forks axis.
5. **Facade Element Positioning System (optional):** Along the corners of the building, rail-guided hoist manipulators (3 DOFS: lift/lower, move along building corner, move to building/move away from building) can travel and pick up, lift and position facade elements.
6. **Steel Column Welding System (optional):** After positioning and aligning of column elements, optional welding robots (rail-guided, attached to the column) can be used.
7. **Plumbing Unit installation System:** A jib crane on top of the factory lifts and positions prefabricated plumbing units once a floor's main structure has been erected by the manipulators. A gate on top of the factory can be opened and closed for this purpose.
8. **Overhead Interior Finishing System:** To further reduce work in elevated places, overhead interior finishing (including plumbing and the installation of aeration systems) is done from the finished lower floor, and the floor element is then raised and installed on the uppermost floor. As such, no temporary scaffolding is required.
9. **On-site Control Room:** An on-site control room for supervising, coordinating and (remotely) controlling all work activity is integrated into the SF structure over the level of the manipulators.

End-effectors: The manipulators' 5 DOFs and double fork structure allows them to perform all necessary installation operations. As end-effectors, simple hooks or clamps were used (for example, for transporting and positioning of columns and beams by OMs).

System Variations: The system has so far been applied without the optional subsystems mentioned above. The optional subsystems are subject to R&D and are conceived to be integrated with the other subsystems. Furthermore, as Takenaka had also developed a series of STCRs (e.g. for concrete distribution, floor finishing), the integration of those with the Roof Push-Up system would add additional optional capabilities and thus variety to the system. The system in total already has inbuilt flexibility, allowing (from ground plan view) non-rectangular buildings to be manufactured.

ROD: On a component level the design of the column elements is a central element of ROD. The columns already contain beam elements welded to them on various sides. This allows the components to be easily transported by the manipulators' double forks. Furthermore, it allows that the positioning and adjusting of beam components between the formerly mentioned components is afterwards simplified. On a building level, and in terms of ROD, a floor plan which concentrates on the one hand on the functional elements (plumbing, vertical ducts, elevators, stair cases, etc.) and on the other hand on the office rooms, allows for the efficient use of the plumbing unit installation system - a speciality of the Roof Push-Up System.

Roof-Robo Automated Construction System

Company: Toda Corporation, Japan

Category: SF (moving upwards) supported by building

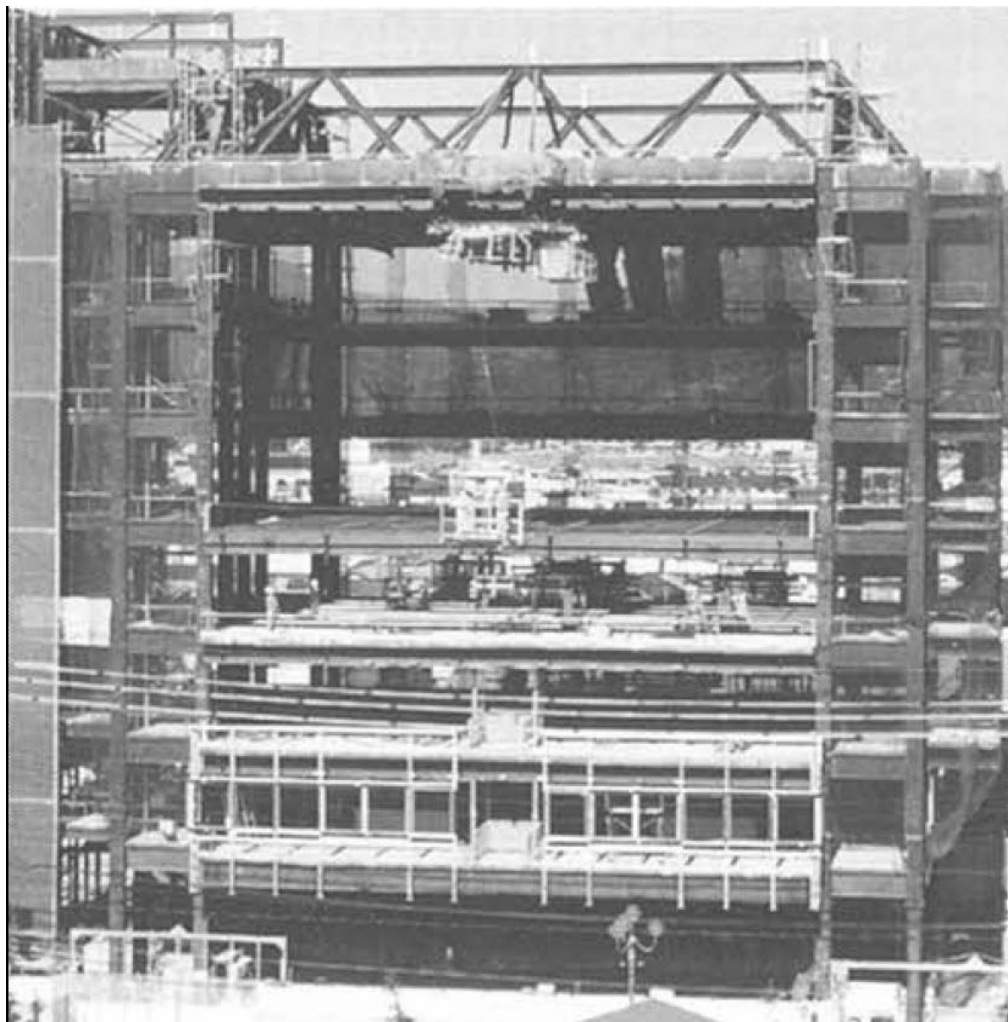

View into the SF, OM, and operational levels (Hasegawa, 1999: p. 467)

Evolution Scheme: The roof structure of the factory is set up on the ground and then lifted up along the stilts supporting it. The first three floors are assembled in a conventional way. From the fourth floor upwards the full operation of the system starts including assembly of superstructure columns on the n th floor, plus parallel processing starts on floors $n-1$, $n-2$ and $n-3$. The SFs' roof truss structures can be integrated into the building as the basic steel structure for the uppermost floor(s) of the building.

Elevation: during full operation, the factory covers the uppermost four floors and ensures that all processes performed before (and during) the attachment and sealing of the facade are done in a SE. OMs are attached to the roof of the SF and are able to pick up components directly from the VDSs. On the uppermost floor under the roof (n th floor) the OMs position the superstructure columns, and the automatic alignments system is applied. On lower levels, beams and, thereafter, the facade elements are installed. Furthermore, after installation of the facade, work on the fireproof coating and interior finishing starts.

Ground Plan: The ground plan shows the arrangement of the SF as well as the position of the GFs. The GFs are connected to the SF directly via two automatic VDSs in order to be able to establish JIT and JIS components (to-site) delivery and installation (on-site) process chains.

Subsystems: The Roof-Robo system consists of many integrated subsystems:

1. **SF Structure:** The SF structure encloses the workspace of the top 3-4 levels, and thus creates a weatherproof, safe and SE for all assembly tasks. Once the facade is installed and sealed, the building leaves the SF and further final finishing work can be done in the sealed interior. The factory roof's steel truss structure can be integrated into the building as the final floor.
2. **CS:** The CS is hydraulically actuated. The steel stilts supporting the SF are pushed up by the actuation mechanism located in the roof truss structure. The stilts rest on the superstructure elements of the building located in its four corners. Each corner of the superstructure consists of four columns, which are positioned, aligned and fixed around the stilt supporting the SF structure. Once they are fixed and connected by beams, the stilt is lifted and fixed by bridging the new superstructure segment. This is done in all four corners of the building; then the factory can be lifted up along the stilts and fixed into the superstructure.
3. **VDS:** An automatic lift transports structural elements into the SF. The lift is especially designed to transport and orientate the superstructure components – the main element of the building. By following a curve on lower level, the lift raises the superstructure columns up from a horizontal position (which is convenient for handling on the ground) to an upright position, allowing them to be directly picked up by the OMs.
4. **Vertical/Horizontal Finishing Material Delivery System:** The finishing material is automatically delivered from the GF to the floors and to the installation location by a forklift-like mobile robot. The mobile robot is compact and lightweight and can thus

travel vertically by an automatic lift, with which it can communicate. The mobile robot has forks and a multipurpose end-effector that allows the transport of palletized and non-palletized material. Specifications of the mobile robots:

- Payload: 1500 kg; weight: 800 kg
 - Dimensions (in meters) 1.3 x 2.7 x 1.2
 - Carrying speed: up to 16m/min
 - The delivery operations are planned and monitored in real-time from an on- or off-site control center.
5. **HDS:** Two OMs with 4 DOFs each (translation along x-axis, translation along y-axis, rotation, and lower/lift of end link along y-axis) are operated on a rail grid attached to the SF's roof. They are used to position the buildings superstructure components, beam/girder elements connecting the four superstructure trusses of the building and floor slab elements. Specifications of the manipulators:
- Payload: up to 6 tons
 - carrying speed: up to 35m/min
6. **Curtain Wall Handling System:** Still within the SF, but on the levels under the uppermost operational floor (n th floor), Toda uses its curtain wall installation robots to install prefabricated facade elements. The elements are transported by the Vertical/Horizontal Finishing Material Delivery System to, e.g. to $n-1$ floor and are then lowered by the robot to $n-2$ level and positioned. Specifications of the robot:
- Payload: 350 kg; weight: 720 kg
 - Dimensions (in meters): 1.9 x 1.6 x 1.8
 - Operating speed: 25m/min
7. **Fireproof Coating System:** On the lower levels within the SF (n th floor to $n-3$), or even on the lower and already sealed floors under the SF, a mobile robot system is used for spraying a fireproof coating onto the structurally active steel elements. The robot travels on wheels and can easily be repositioned on a floor level horizontally or be transported vertically by the finishing material lift. Once positioned, the robot has the ability to process steel elements in a working space area of 1, 5 (width) x max 5 m height. The robot Specifications of the robot:
- Weight: 350 kg
 - Dimensions (in meters): 2.6 x 0.8 x 1.4
8. **GF (optional):** Toda can install ground yards for material handling material storage and component preparation. The ground yards are additional structures that are connected to the two vertical transportation systems. They allow trucks delivering material to drive into these yards and unload material in a weather-protected environment.

9. **Automatic Column AAMS:** After positioning by the OMs, the columns of the superstructure are temporarily fixed by clamps that are actuated by servomotors. The alignment of the column over component integrated reference points is measured by 1-D laser scanners. Then the motors actuate the clamps and automatically align the column to the required position.
10. **Work Process and Material Delivery Management System:** Toda uses a software tool to simulate work processes and to automatically generate work instructions and material delivery schedules (for example, for the operation of finishing material lift). An additional software tool is used to manage and control the JIT material flow and the operation of the two VDSs in real-time.

End-effectors: Both overhead gantry type manipulators and the V/HDS use simple (conventional crane-like) multipurpose end-effectors.

System Variations: In its current version the system can be applied to buildings with different heights, widths and lengths that are based superstructures. The CS must be able to climb along with the superstructure. The length and width of the building are restricted by the strength of the SF's roof structure (and thus its ability to span space between the super-structures).

ROD: On a component level, ROD is applied to the column components used to build up the superstructure and to the facade elements. The columns have temporarily fixed steel plates attached at the top end which allow them to be picked up by the manipulators hooks. Furthermore, the components have integrated reference points which allow the efficient use of the automatic column AAMS. On a building level it has to be considered that for efficient operation, the building structure needs to be based on a superstructure. Unlike other systems, the roof structure system is supported by only four stilts, which rest on and climb along the four corners of the superstructure. The reduction of factory structure supporting stilts reduces the complexity of the CS. On an urban level, the allocation of the vertical lifts and the ground-level adjunct MHSPYs need to be considered when deciding on the orientation of the building in the environment.

Shimizu Manufacturing System by Advanced Robot Technology (SMART)

Company: Shimizu Corporation, Japan

Category: SF (moving upwards) supported by building



SF

Evolution Scheme: The SMART SF roof structure (and the subsystems attached to it) is assembled on the ground and then lifted along the supporting steel stilts up to a height at which operation can start. To begin with, the supporting stilts rest on levels that have already been finished. After the construction of the first floors by the system, the stilts/climbing mechanism can use these newly constructed floors to lift the SF. Full utilization of the SF (including its capability of also providing a structured work environment for the outside facade work) can start from the 3rd floor upwards. Furthermore, after the construction of the 4th floor, a material handling system can be deployed on the ground floor. After the dismantling of the factory covers and manipulators, the roof structure of the SF can be integrated into the building as the uppermost floor (for example, as the service floor containing the aeration system etc.).

Elevation: The SMART concentrates work activity in an SF. In contrast to other systems, the OMs do not have a fixed main trajectory (such as 1-3 lengthwise trajectories as is the case of ABCS, for example) but can travel freely throughout the whole system. Up to 25 manipulators (trolley hoists) can operate in parallel, and travel from the material handling space on the ground floor, via an automatic lift into the SF where they can move to any component installation location via a (movable) gantry crane rail-system. Furthermore, in contrast to other systems the steel stilts that support the SF and are part of the climbing mechanism do not rest on top of the columns but between them – thus the climbing process interferes less with component assembly process. Within the SF, work is done on three to four levels in parallel. Components are positioned and aligned on the uppermost floor (the *n*th floor). Activities such as component fixation, interior finishing and facade work (over platforms provided by the SF) are done on the floors below. Once the SF moves a floor higher, a completely finished floor leaves the factory at its lower end.

Ground Plan: A system of mobile overhead cranes is synchronized with the building shape and the column grid-system of the building. Multiple mobile overhead cranes travel in fixed direction lengthwise the building. However, the trolley hoist manipulators can travel perpendicular to the direction of the cranes (and therefore also between them). Thus the trolley hoist manipulators can travel to any point in x/y (length/width) direction. As the stilts supporting the SF structure do not rest on columns but between columns, they do not permit the trolley hoists to position components directly over a column. The trolley hoists pick up components from the ground floor, travel with the component over the automatic vertical lift into the factory and then travel via a transport channel (multiple mobile overhead gantry cranes can form a line profile), allowing the trolley manipulators to move along it.

Subsystems: The SMART system manufacturing the building on-site by way of an SF consists of a multitude of integrated subsystems. The trolley hoist manipulators freely travel throughout the system by automatic vertical lifts and automatic overhead cranes. They thus integrate vertical and HDSs and take away the necessity of handing over components between them, thus eliminating waste processes (Consider the waste which occurs in other systems due to the handover between vertical and HDSs, e.g. the resulting idle time of the

component and the time necessary to accomplish handover; additionally consider the possibility of damage to components during handover).

1. **Material Handling System (ground level):** As the trolley manipulators pick up material from the ground level, a material handling space on the ground is necessary that allows an overhead crane or rail system to be positioned directly over the components to be stored or delivered. Picking up directly from a truck that can be driven into the material handling space allows for JIT processing of components delivered to the site. The material handling space can be constructed as a temporary structure next to the building itself, or integrated into the lower floors.
2. **SF Structure:** The SF completely covers the building and creates a weatherproofed and structured working environment for all automatic and manual work activities conducted between the n th floor and floor $n-3$. The SF roof structure is supported by steel stilts which rest between columns on the floors under the uppermost operational floor. The roof structure cantilevers over the building's edge and thus also provides working platforms for the facade work. The vertical trolley manipulator lifting system, as well as the system of overhead cranes (which provide the basis for the free travelling of trolley manipulators in the system), are directly integrated and mounted onto the factory roof structure.
3. **CS:** Four lifting stilts are positioned inside the factory to lift the whole factory. In contrast to many other systems which use SFs, the hydraulic lifting mechanism is not located in the roof structure itself but on the bottom of the stilts. Inchworm-like, the mechanism moves from floor to floor, pushing up the stilts and thus the factory.
4. **Trolley Hoist Manipulator System:** In the SMART, up to 25 trolley manipulators are operated in parallel. Each trolley manipulator can travel between material handling systems on the ground and the SF's automatic overhead gantry crane system, thus integrating pick-up, vertical delivery and positioning processes.
5. **SF HDS:** Multiple mobile overhead cranes travel the building in a fixed lengthwise direction. However, the trolley hoist manipulators can travel between the cranes. Thus, the trolley hoist manipulators can travel to any point on the XY-axis. Multiple overhead cranes can build a line (transport channel) along which the trolleys can travel.
6. **VDS (lift of trolleys/manipulators):** The trolley hoists pick up components from the ground floor and travel with the component via the automatic vertical lift into the factory. Together with the automatic overhead crane system, the trolley manipulators used during a component positioning operation in the SF have 4 DOFs (translation of overhead crane, traveling of trolley manipulator along crane profile, turning of trolley head, lifting/lowering). When the lifting process and the traveling of the trolley in the material handling system on the ground are taken into account, the trolley manipulators actually have more than 4 DOFs.

7. **Welding Robot System:** Compared to other welding robot systems, the Shimzu welding robot system used within the SMART is compact and lightweight. It consists of a ring which encircles the column and a single welding robot guided by this ring. Many of these systems can be used in parallel. Each welding robot system determines its welding path by a laser sensor and automatically welds the steel columns together. Eventually the transportation device still attached to the welded column is removed automatically.
8. **RTMMS:** Each construction element is tagged with a barcode. This code is scanned and the individual element is processed by the distribution system according to its position in the building. For an accurate positioning of the steel columns, the laser measurement system is deployed. A control room is located in the roof structure of the SF.

End-effectors: All trolley hoist manipulators are equipped with multipurpose hooks, which are lowered/lifted by two ropes from the trolley manipulator's main mechanical part. The simplicity of the end-effectors is accomplished as the system does not necessitate to position columns under the SF's supporting stilt and as the trolleys pick up components already in correct orientation (e.g. columns in upright position) in the ground floor.

System Variations: The SMART is a fully modular kit. The system can be used to construct rectangular as well as non-rectangular buildings with an orthogonal alignment of components. If non-rectangular buildings are built, the shape of the building has to be synchronized with the length of the overhead cranes, providing the travelling axis for the trolley manipulators. The SMART can be operated with one, two or even more vertical trolley transport channels. The more trolleys that are intended to be used in parallel, the more transport channels are needed.

ROD: On a component level, the complexity of the column installation process is reduced by ROD through the use of compliant and self-adjusting joints (rack and pinion system). On a building level, the structure of the overhead crane system has to be synchronized with the shape and dimensions of the building, and the shape and dimension of the SF structure. On an urban level, according to ROD principles the location of the material handling system on the ground and the location of the vertical transportation channels ought to be considered when designing and deciding on the orientating of the building.

System Netherlands

Company: Royal BAM Group, Netherlands

Category: SF (moving upwards) supported by building



SF

Evolution Scheme: This system was introduced in the Netherlands by a major European construction company, "BAM". This is more like a mechanized construction system. A speciality of the system is the high ratio of prefabrication. Highly prefabricated wall and facade concrete based components (many, for example, already containing windows etc.) are delivered to the site and installed by the manipulators. After positioning and adjusting, these highly prefabricated components only require a small amount of additional work (e.g. sealing) so that the complexity in the SF is reduced and a structured work environment is created. The construction factory is built first, and this keeps moving up while the successive storeys are constructed from the bottom up. Such a construction factory comprises two overhead crane manipulators with a capacity of 40 tons each. One of these crane manipulators is simple with a hook to lift the elements up and down and to reach up to any point within the building's perimeter. The second overhead crane manipulator provides the main vertical material delivery system. It also has a double-girder overhead, but with some extra functions which leave it resembling an automated delivery robot. The only difference is the autonomy in working. Finally, the construction factory is removed and the building structure is completed. Finishing work on each floor is done in parallel to the raising of the SF.

Elevation: The elevation reveals the interplay of site logistics, OMs and climbing strategy in detail. The vertical transportation of components is performed by an OM (with 4 DOFs). One end of the construction factory is extended beyond the building perimeter and kept open for the vertical on-site logistics. One of the overhead crane manipulators picks the material up from the ground outside of the building, transports it vertically to the required height and then moves horizontally to place the material at required location. The second overhead crane manipulator has a revolving head which assists in placing the building member at right position and orientation. The CS acts as an inch-worm system. This system is attached with a truss-like structure at the bottom end and when it is supposed to raise the factory up after the completion of each floor it is connected at the top end as well. It is installed outside of the building's perimeter.

Ground Plan: There are two working platforms the length of the building. These are outside the perimeter of the building and supported by the construction factory's frame structure. The system utilizes two OMs as its central element. Both are integrated in and rail-guided by the SF structure. The first manipulator is remotely controllable and has 3 DOFs: This is a conventional overhead crane with a lifting capacity of 40 tons. It also comprises of two girders and lifting motors with a simple hoist. It is controlled manually. It serves the purpose of on-site logistics on each floor for material transportation. Similar to the second manipulator, it runs on the rails which are fixed to the construction factory's frame structure. One side of the building is kept open for the vertical logistics. All the construction material is lifted up from this open end with another 4 DOFs remotely controllable manipulator. As soon as the elements reach the desired floor, the same crane moves horizontally, heading towards the designated location. The rotating head of the crane assists in placing the element in its proper orientation.

Subsystems: The System Netherlands manufacturing the building on-site by way of an SF consists of many integrated subsystems:

1. **SF Structure:** The SF covers the workplace on top of the building and creates a SE for both human activities and manipulator operations. Further complexity is reduced through the processing of high-level concrete components in the SF. The construction factory is held by a steel frame, which also provides support to working platforms all along the building at two different levels. These platforms are outside of the building's exterior perimeter walls. Additional tubular truss-like frames are installed at two locations near the shorter ends of the building. Climbing mechanisms which push the construction factory up after the completion of each floor are connected with these two truss structures. One side of the building is kept open for the vertical logistics. All the building materials/elements are lifted up from this open end with the crane, which operates manually. As soon the elements reach the desired floor, the same crane moves them horizontally towards the designated location. The rotating head of the crane assists in placing the element in its proper orientation.
2. **CS:** It acts like an inchworm system. Every time the construction of a floor is completed, a new support truss structure is erected at the top of the floor. This system is then disconnected from the bottom, and it moves up. Finally, it pushes the whole construction factory up by one floor. The process of climbing can be described as follows:
 - Step 1: Construction factory is erected after completion of the ground floor (including all other related systems like climbing mechanisms, cranes, supporting truss structures, internal supporting steel frames).
 - Step 2: First floor construction is completed utilizing the construction factory and its related systems.
 - Step 3: An additional supporting truss is erected.
 - Step 4: The bottom supporting truss is removed and the climbing mechanism starts acting as an inch-worm system, and slowly pushes the whole construction factory up.
 - Step 5: The construction factory has now moved up by one floor and the construction of the new floor starts. This is the same stage as at step1, but one floor higher. These processes are repeated until the whole building is completed to the top.
3. **VDS:** Building elements are vertically transported from outside of the building's perimeter using a 3-DOF crane manipulator through an inward-bound weather-protected port.
4. **HDS:** Mechanized crane manipulator with 4 DOFs. Modified conventional overhead crane with a revolving head which in turn has a lifting capacity of 40 tons for on-site logistics. It has a revolving head between two girders for easy positioning of elements and runs on rails integrated into the SF structure.

5. **RTMMS:** The construction system presented here is a mechanized system. Although this was an effort to construct in an unconventional way, it lags behind a lot of the Japanese systems. The on-site logistics need to be automated, the construction elements barcoded for easy identification and a material management system introduced. At the moment, the vertical and horizontal logistics resemble a typical manually operated industrial overhead crane.

End-effectors: Vertical and HDSs are respectively equipped with a fixed but different multipurpose end-effector:

1. VDS: hoist with multiple hooks
2. HDS: hoist with one hook

System Variations: In-situ concrete placement is practiced in this system, which can be replaced with precast elements for rapid construction. There is a need to design the joints for easy installation of these precast elements. The vertical transportation ought to be shifted inside the building (in a controlled environment) to be less affected from external factors.

ROD: The wall components in system Netherlands are precast and the design accommodates the highly precise use of robots to enable accurate installation. There are conduits installed in the precast wall elements through which steel reinforcement is passed and which connects the successive elements.

5.2.2 Sky Factory (moving upwards) on Stilts (extending)

Like with the previous category, the systems described in this category are used to assemble buildings from bottom to top. The factory where component installation is done sits on top of the building. However, in contrast to the systems outlined in the former category, the SF does not rest on the structure of the building itself, but is supported by its own structure, which transmits the forces directly to the ground. Furthermore, in this category, SFs only provide a roof structure, not a completely sealed working environment. As shown in 5.4 (efficiency analysis), this nevertheless considerably reduces the influence of sun, wind and rain on the work environment. Through the support on and won structure the systems are more independent from the building structure and require less integration with it which enhances the application scope and thus the utilization rate of the systems. Furthermore, through the simplification of the factory (roof only), the systems are less capital intensive.

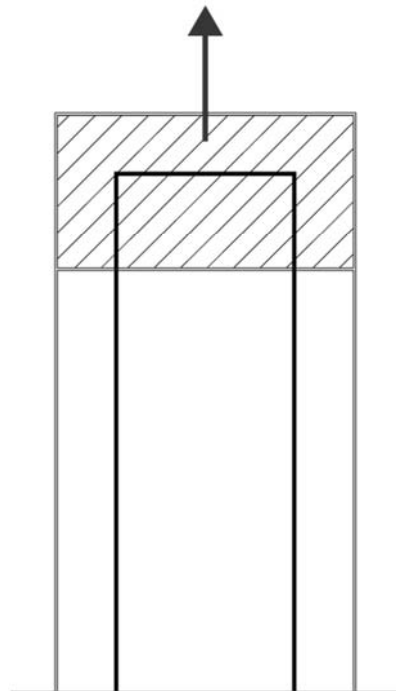

	System Name	Company
9	Big Canopy	Obayashi
10	SMART Light	Shimizu

Big Canopy

Company: Obayashi Corporation, Japan

Category: SF (moving upwards) on Stilts (extending)



View into SF (HDS)

Evolution Scheme: In the case of the Big Canopy, a roof structure is set up on ground level and then lifted over four steel stilts in its corners to an operational level. The system supports the construction of the first two levels and starts full operation from 3rd floor upwards. The stilts are located besides (i.e. not within) the building's structure and transfer loads generated by the SF and its subsystems to the ground. The stilts are composed of standard crane segments and are extended over a jib crane, which sits on top of the building. This feeds new stilts segments from top into the SFs roof structure so that the CS can lift the roof structure along the extended stilts. Upon disassembly of the SF, roof structure is lowered in parts to the ground along the supporting stilts.

Elevation: The elevation shows that the roof structure of the SF rests on a separate structure and, unlike systems of the former category, is constructed on top of the floors. This provides independence from the buildings column system and also allows the processing of heavy reinforced concrete elements. The SF is not completely covered but the rain and sun protection is considered to be sufficient. Rail-guided OMs are attached to the roof structure. An automatic lift (a variation of the automatic lift used in ABCS) accomplishes vertical logistics. The system is utilized to install medium level prefabricated concrete components (columns, beams, floor slabs, balcony components, facade components). Therefore, the buildings are modularized into concrete component kits. To attach components and seal gaps *in situ*, not prefabricated concrete was used in parallel.

Ground Plan: The roof structure of the Big Canopy SF allows rail-guided OMs to be installed onto it. The main operation direction of the OMs is lengthwise and up to three OMs can be installed side by side. One automatic lift supplies the components to the OMs. The process of installing components (pickup, lifting, positioning, etc.) is simulated by a software tool and the operational sequence (and thus the configuration of the SF) is optimized by software tool.

Subsystems: The Big Canopy system of manufacturing buildings on-site consists of many integrated subsystems:

1. **Factory Roof Structure:** The factory roof structure is made from a modular steel frame system and is adjusted for each new building. The operational floors are protected by the roof structure but not completely covered. The control and structuring of the environment is thus unable to fully control all environmental factors, but provides more freedom, faster installation and disassembly of the site factory and for a lower investment/fixed cost. As with other systems, rails guiding OMs are attached to the SF roof structure.
2. **CS:** The factory rests and climbs; the CS is located in the roof structure and hydraulically pushes the roof structure upwards along four steel stilts. . Upon disassembly of the SF these parts of the roof structure are lowered to the ground along the supporting stilts.

3. **VDS:** An automatic lift (an adjustment of the automatic lift used in ABCS) accomplishes vertical logistics. Similar to the four steel stilts along which the SF climbs, the stilts along which the automatic lift runs can be extended by the jib crane on top of the factory or by the OMs.
4. **HDS:** The HDS is installed into the roof structure in the form of rail-guided OMs. Two completely different OM system configurations have been developed:
 - a. **Type 1:** Two rail-guided manipulators with 5 DOFs (translation lengthwise, translation widthwise, rotation, forward/backward translation of main link, lower/lift of final link) and simple multipurpose end-effectors. The workspace of the en-effectors overlaps in the middle so that both manipulators have equally full access to the automatic lift.
 - b. **Type 2 (e.g. Big Canopy applied in Singapore and Chiba):** Multiple hoist manipulators travel horizontally via an overhead rail and gantry crane system. One high-speed rail-travelling delivery gantry crane sits in the middle. Two gantry cranes flanking the delivery gantry crane in the middle. The central delivery gantry crane can take up two hoist manipulators (one empty hoist coming in from a flanking gantry crane, having installed its component; one hoist carrying a component to be installed). With one operation the middle crane thus carries one manipulator hoist with a component to a flanking crane and in the same operation delivers an empty manipulator hoist over the automatic lift to pick up a new component. This results in a reduction of idle time or waste processes. As the travelling hoists themselves only allow the bringing of a component over the installation location for orientation robotic end-effectors (with an additional 2 DOFs; attached to the hoist manipulators) each gantry crane provides 1 DOF (translation lengthwise the building), and the hoist manipulator adds two more DOFs (translation, Lift/lower). So, in total, the HDS in this configuration provides 5 DOFs.
5. **RTMMS:** Software tools are used for the simulation and optimization of the operational sequence.

End-effectors: The manipulators (HDS) can be equipped with various end-effectors:

1. HDS type 1: simple multipurpose end-effector
2. HDS type 2: robotic end-effector for component orientation (2 DOFs)

System Variations: The independence of the system from the column grid structure makes it more flexible and easier to adjust (less pre-planning and pre-investment needed). For experimental and optimization reasons, two types of HDS were developed, one with a manipulator approach and one with a travelling hoist manipulator approach.

ROD: The system has been utilized to install medium level prefabricated concrete components (columns, girders/beams, floor slabs, balcony components, facade

components). Therefore, the building is modularized into a concrete component kit. To fix components and seal gaps *in situ*, concrete was used in parallel. The components are optimized in terms of their dimension, shape and weight to suit the use of the OMs.

SMART Light

Company: Shimizu Corporation, Japan

Category: SF (moving upwards) on Stilts (extending)



SF / HDS (OMs in action)

Evolution Scheme: The SMART Light is an altered and simpler version of the SMART. The SMART Light does not cover the workplace with a roof or side sheets but embraces the building with a steel frame, allowing various delivery systems and manipulators to be mounted to it. The steel frame, as well as the steel stilts on which the frame is lifted, is composed of standardized frame segments. The steel stilts on which the frames are mounted are an independent building structure erected besides the building. They transfer the load to the ground, making the erection of the steel frame independent from the building's column grid. The system can be erected on the ground floor over the floor area and can support the erection of the lower floors or even basement floors.

Elevation: OMs are installed on the steel frame. Various jib cranes can also be mounted on top of the steel frame. The vertical delivery of parts and components is accomplished via the jib cranes. The vertical stilts stand right beside the building, and in order to achieve stability are connected to the building by cross beams approximately every fourth floor.

Ground Plan: The ground plan shows that the steel frame spans the building in a way that allows 1-3 gantry type OMs to be installed, so that the workspace of all manipulators together covers the buildings floor area. The jib cranes on top are installed on top of the frame and in the middle of each of the shorter sides of the building. The workspace of the jib cranes spans the whole building and allows the lifting up of parts and components from delivery or storage locations on the ground. As the frame structure is not covered by a roof, the jib cranes and OMs can operate in parallel.

Subsystems: The SMART Light on-site building manufacturing system consists of many integrated subsystems:

1. **Frame Structure:** The frame structure consists of standardized segments and provides a platform for the installation of various OMs and jib cranes.
2. **CS:** The CSs consist of a hydraulic actuated inchworm-like CS, which raises the frame structure to which manipulators and cranes are mounted along the stilts of. To lengthen the stilts, the jib cranes place a new segment on top of the end of each of the stilts.
3. **V/HDS:** jib cranes mounted to the steel frame operate in parallel to the OMs and accomplish vertical as well as horizontal delivery tasks.
4. **HDS:** Gantry type OMs with 3 DOFs (translation lengthwise, translation widthwise, lower/lift of end link) – simple multipurpose end-effectors. For reasons of compactness, and to avoid collisions, two outer manipulators are guided by rails at the bottom of the frame, the middle manipulator by rails on top of the frame.
5. **Movable Roof Cover Segments (optional):** Movable roof cover segments can be mounted to the top of the frame, covering some dedicated work places temporarily, as well as parts of the workspace of the OMs. For delivery of components by the jib cranes, the roof can be re-moved automatically.

6. **RTMMS:** The control stations/rooms for the manipulators, as well as for the jib cranes, sit on top of the frame. The gantry-type OMs can be operated in automatic mode as well as via remote control.

End-effectors: Both the overhead gantry-type manipulators and the vertical HDS use simple (conventional crane-like) multipurpose end-effectors.

System Variations: As both the steel stilts and the horizontal frame are composed of standardized linear frame elements, and as the system is independent from the column grid structure of the building. It is highly flexible. Widthwise, 1-3 gantry-type manipulators can be installed. Lengthwise, the length of the frame girders can be varied. Furthermore, by adding two new stilts, a second frame with an additional 1-3 manipulators can be added to the lengthwise direction, so that “long” and horizontally oriented buildings can also be erected.

ROD: An advantage of the system is its independence from the building grid structure, its flexibility/variability and its simplicity, which allows fast set-up. Due to its independence, as well as the multipurpose nature of the end-effectors, the necessity to re-design components is almost removed. However, the system cannot achieve the same operational speeds or automatic capability of the SMART.

5.2.3 Sky Factory Pulled up by Core (main factory and core factory moving upwards)

Systems in this category of buildings are assembled from bottom to top. The lifting of the SF is accomplished by pulling it upwards along a central core structure (steel or concrete), which is assembled a few floors in advance. In the case of Taisei's Totally Mechanised Construction System for High-rise Buildings (T-Up system, for more detail see the following section), three on-site factories are deployed thus:

1. A GF, which converts parts and components into medium or higher level components.
2. A core SF around the building's core, which manufactures the core structure in advance and which sits on top of the main SF
3. The main SF, which is pulled upwards along the core structure

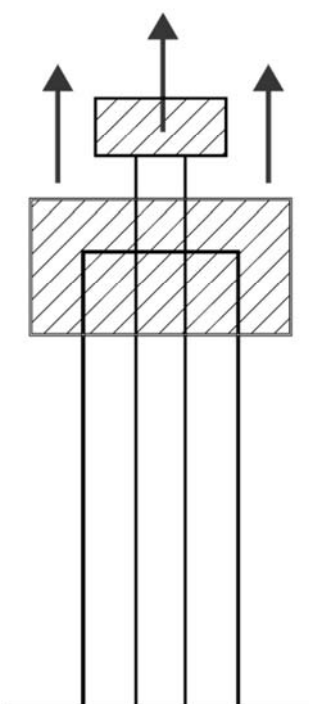

	System Name	Company
11	Totally Mechanised Construction System for High-rise Buildings (T-Up)	Taisei
12	Robotic and Crane based Automatic Construction System (RCACS)	Korean Consortium

Systems in this category are limited to the assembly of buildings with a central core. However, they utilize the characteristics of this building typology for the purpose of automation. Since the core itself is often a simple and highly repetitive structure, its assembly can easily be systemized. The manufacturing of the building's core by the core

SF fulfils the characteristics of a 'line construction site' (for more information on the mechanization and automation of line construction sites by TBMs, see **3.3.1**) and is characterized by mainly vertical logistics and installation activities along the core. In contrast, the larger main factory (which is pulled upwards along the core produced by the core SF) has higher variability of functions as well as a higher integration of vertical and horizontal logistics and installation operations.

Totally Mechanised Construction System for High-rise Buildings (T-Up)

Company: Taisei Corporation, Japan

Category: SF pulled up by Core (main factory and core factory moving upwards)



SF (picture taken from Taisei brochure)

Evolution Scheme: In the case of the T-up system, a part of the SF is dedicated to manufacturing the core of the building. It does this automatically and then provides a basis for the automatic raising of the main SF in which the automatic manipulators operate. The T-up system thus visualizes the principle of robotic self-reproduction. The relevant part of the structure for the SF is the uppermost floor of the building, which is erected and finished on the ground and then pushed up along the core structure.

Elevation: The elevation shows the interplay between the smaller SF which houses the climbing mechanism (hereafter SF part 1), and the main SF (hereafter SF part 2), which sits below the smaller of the two. In the following overview of the system, the term 'SF' is used to refer to the two parts combined.

If a full GF is installed on the ground, the whole process of transforming low-level components into higher level components is fully automated on-site, as is the delivery to and installation of the transformed components in the SF.

Ground Plan: The ground plan shows the working area of SF part 1 and SF part 2 robotic manipulators. In SF part 2, robotic trolley manipulators travel along an integrated rail-guided, gantry crane system. The trolley manipulators integrate vertical and horizontal delivery, thus erasing the need for the handover of components between vertical and HDSs. Component-type adjusted end-effectors simplify pickup and installation processes.

Subsystems: The T-Up system manufacturing the building on-site consists of many integrated subsystems:

1. **SF Structure:** Covers the workplace and creates a SE. In the case of the T-Up system, two SFs are arranged one above the other.
 - **Factory Part 1 (upper/core SF):** Factory part 1 provides a SE for the manufacturing of the building's core, which enables the climbing of the whole SF. The factory is equipped with side covers and integrated with rail-guided jib cranes as part of the OM system. It is the platform for the installation of the measurement and steel column alignment system.
 - **Factory Part 2 (lower SF):** Factory part 2 provides a SE for the erection of the building around the building's core and the installation of facade elements. Unlike the factory part 1, factory part 2 is not equipped with side covers. It is the platform for the installation of OMs. The relation between part 1 and 2 is symbiotic; part 1 manufactures the core of the building in advance to enable the operation and upward climb of factory part 2 (and with it part 1 also). The SF platform, which forms the basis for factory part 1 and 2, is also the uppermost floor of the building, and after completion is integrated into the building itself.
2. **CS:** The CS lets SF part 2 climb up the inner core manufactured within factory part 1. Hydraulically actuated climbing stilts climb inchworm-like along every second steel column of the inner core, and therewith carry up SF (both parts). In total, taking into account all climbing stilts, the CS has a lifting capacity of 2000 tons.

3. **V/HDS 1 (jib crane manipulators):** On top of the SF's main platform (part of factory part one), two rail-guided robotic jib cranes are installed. These lift and position the steel parts and components.
4. **V/HDS 2 (OMs):** The main element of factory part two is a system of rail-guided OMs. Two hoist manipulators, each capable of lifting parts and components of up to 10 tons, are able to travel along rail-guided automatic overhead cranes to any position within factory part 2. The gantry crane system allows the manipulators to travel to cantilever positions along both the sides and ends of the factory, and thus to directly pick up parts and components from the ground or GF. In combination with the automatic overhead crane system, each manipulator has 3 DOFs. Various component specific end-effectors can be attached to the manipulators, adding additional DOFs.
5. **Interior Finishing Systems (optional):** Taisei can use its STCRs (logistics and interior finishing robots) in finished and weatherproofed floors under the SF to finish the interior of the building.
6. **On Ground HDS (GF, optional):** On the ground, Taisei can optionally install a rail-guided AGV for the transport of material from trucks to the on-site BCM line, to storage or to the component pick-up tables.
7. **On-site BCM Line (GF, optional):** Taisei has developed a modular and temporarily installable manufacturing line for the concrete-based floor and facade elements. The manufacturing line can deliver components directly to the pick-up tables.
8. **Component Pickup Table (GF, optional):** Along the side of the building, rail-guided automated component pickup tables position components for collection by the V/HDS 2. The component pick-up tables orientate the components to be picked up in a standardised way and thus simplify an automated pick-up by the OMs. They are a kind of factory internal component palletising system that simplifies FIL.
9. **Underground Excavation System (optional):** Taisei can operate automatic excavation and soil removing systems in parallel to the operation of the SF in order to facilitate the construction of multiple basement levels.
10. **AAMS:** A laser based automatic system for measuring and aligning steel columns is installed in SF part 1. In addition to the columns, the system also measures the alignment of the construction. A precisely manufactured inner core reduces alignment complexity in the lower of the two factories (part 2) and guarantees precision in all following manufacturing sequences.
11. **RTMMS:** The on-site automatic material flow (e.g. between GF and SF) and the progress of the installation of components is supervised in a control room located on the SF's main platform structure. Additionally, on the basis of CAD data, the progress of construction on-site can be monitored. The operation of the OMs and the component installation can be monitored in real-time. Workers are also equipped with handheld

devices (smartphones, tablet computers) where they can view and thereafter accept all necessary work tasks. The handheld devices are equipped with barcode or Radio Frequency Identification Tag (RFID) readers to allow workers to identify and track components.

End-effectors: The manipulators (V/HDS 2) can be equipped with various end-effectors to enable the picking up, positioning and adjusting of various component types:

1. End-effector for picking up, positioning and adjusting of columns
2. End-effector for the positioning of beam/girder elements
3. End-effector for picking up and positioning concrete floor slabs
4. End-effector for positioning of prefabricated large-scale facade elements

System Variations: The T-Up system can be applied in different configurations. SF part 1 and 2 can be connected (for the erection of buildings with a steel based inner core) via a raised roof platform, on top of which robotic jib cranes carrying robotic OMs would be mounted. If a building with a concrete core is erected, factory parts 1 and 2 are disconnected. Part 1 would then completely enclose the automatic concrete core production by automatic slip forming technology. The cover of factory part 1 can also be equipped with an OM, as an option. Another option is the installation of a GF to automatically finish and provide material to the SF.

ROD: On a component level, ROD is used to synchronize the dimensions, shape and weight of the components to be delivered to and processed in the SF. In order to reduce complexity in the SF, (medium level) components can be prefabricated off-site or in an optionally installable GF, as mentioned above. Pickup tables standardize the collection of components and further allow the complexity of the installation process to be reduced. On a building level it can be decided in the design phase to apply the system only to buildings with a core structure; at this stage it can ideally be ensured that the building will have a near quadratic ground plan in which components will be organized orthogonally. On an urban level it should be ensured in the design phase that the area around the building will be free-standing, and that space will be available around the building for pickup tables.

Robotic and Crane-based Automatic Construction System (RCACS)

Company: Korean led consortium - KAIST, AIST (Japan); Doosan E&C, Ubiz Plus, Shinho System, CSSE, SMEC, M-Plus, Cospec, Robotous, Korea University, Yonsei University, Kunkuk University (Korea); S.I.T. (USA)

Category: SF pulled up by Core (main factory and core factory moving upwards)



HDS/ OM

Evolution Scheme: As buildings have become larger and taller, the number of tower cranes used per year has increased (by over 150% from 2001 to 2005 in Korea, for example). Now, more than 3000 tower cranes are used every year in Korea. However, the serious accident rate in Korea related to tower cranes is relatively very high compared to those in the USA and Singapore. The decreasing number of manual workers and modern construction's need for greater accuracy has made the automation of construction a critical issue. However, the history of construction automation in Korea is relatively short-lived compared to that of more advanced countries. A potential solution to the accident-rate problem commenced in 2006 - the Korean government initiated a five-year project to develop an automated construction system for high-rise buildings (the Robotic Crane Project). Out of this project, Korea has developed an intelligent robotic tower crane system. Over 20 organizations, including research institutes, universities, structural engineering firms, and construction companies have been involved in this project. More advanced countries have had over 25 years of history in construction automation. The ultimate goal of this project was to develop an SF, bolting end-effectors, a robotic crane, and an integrated project management system.

Elevation: In the monitoring and control system, all data from the system sensors are gathered through the integrated system protocol. Then, the Real-Time Progress Management (RTPM) and Real-Time Visualization System (RTVS), the subsystems of the monitoring and control system, examine the construction progress and display the status of the construction progress in 3-D. In the material assembly system, materials and structural steel frames are transported into the SF using a tower crane installed in the core of building. A beam assembly system transports the bolting robot system to the working space in the SF, where it executes the bolting process. In the SF, the weight of the developed system is less than 500 tons, whereas under the previous system it would have been over 1,200 tons.

Ground Plan: RCACS system is created for only one type of structural building typology – tower building with central core shaft. The whole assembly is designed to this purpose: building around a main structural core, therefore any kind of asymmetrical plan is not suitable for this kind of building algorithm. The construction factory climbs while the building is erected using the core building system as vertical and structural support.

Subsystems: The RCACS manufacturing the building on-site consists of many integrated subsystems:

1. **SF Structure:** The factory is composed of eight structural modules fixed to the main structural core of the building. As this central core rises, the hydraulic jacks push up the factory. The SF, based on the concept of advanced automation construction systems, comprises a roof and walls covered with sheets for providing a weatherproof working space. These SF models also have an opening in the roof for the use of the tower cranes present, and for lowering the structural steel frame for erection.
2. **CS:** The construction factory is pushed up by an inchworm climbing subsystem. The hydraulics work in two steps: in step 1 they push the factory up; in step 2 they climb up

the wall, sliding along the steel consoles using a rolling system. The climbing mechanism is a subsystem of the construction factory and comprises eight inchworm hydraulic jacks, which push the factory further up the structural core after completing each level. At first the hydraulics lock their lower part into the guiding steel frames which supports them on the structural core and their upper part starts to push the construction factory up. After they have reached their maximum expansion, they lock their upper part, releasing the lower one and start to contract their lower part up the same guiding steel frame. This process (inchworm climbing) enables the construction factory to climb up to the desired positions. According to the developers, the maximum climbing speed is 200mm/minute.

3. **V/HDS:** A robotic tower crane sits on top of the core and rises with the factory. The intelligent robotic crane is the main logistic asset of the RCACS system used in supplying the construction site with materials and building components. The robotic crane delivers components via the SF's automatically opening and closing roof section. It can directly position components (column components, beam components) or deliver the material for further manipulation and assembly by the robotic overhead crane. It is a modular crane having a total of 6 DOFs in manipulation. The robotic crane can be automatically controlled by the material management system and the lifting path planner.
4. **HDS:** The system has a total of 5 DOFs: 3 translations and 2 rotations. This allows the manipulator to be driven into any desired position. A variation of the system consisting of an added laterally disposed tool, bellow, or alternatively just changing the existing bolting tool with something else, such as a welding tool. The robotic overhead system consists of the following subsystems:
 - "Intelligent girder" able to adjust its dimensions and move.
 - Chassis for translation along hat-truss.
 - Module for manipulation allowing 3 DOFs.
 - Component worker transport and assistance.
 - Guiding system (magnetic based) for tool positioning.
 - Tool for bolting girders with camera vision system.
 - Travel guidance system: Due to the fact that the manipulator needs to travel and make turns, the distance between its supporting points is variable. Therefore, it also has to be able to change its length and the orientation of its joints (magnetic positioning guide, Camera vision control, bolting tool).
 - The robotic overhead system can be equipped with various end-effectors (e.g. for bolt positioning and bolting).
5. **Material Management System:** The material supply system was designed to have a complete database containing all the components and their special features. The developers focused on designing a visual construction process by using a multi-dimensional CAD and RFID technology. The system is called the RTPM (Real-Time Progress Management) system and it is designed to monitoring the components, from

their production in the plant to the final assembly process. The Material management system is integrated with the Real Time Visualization and Control System.

6. **Real-time Visualization and Control System (RTVS):** Visualization & control module: HMI (Human Machine Interface) for emergency stops / other manual operations. It contains the following subsystems:

- Lifting path planner.
- Module for tracking lifting paths.
- Automated lifting module: monitors/adjusts differences between planned path - actual path.

End-Effectors: Various tools (end-effectors) can be mounted to the HDS (robotic overhead crane). The base component and end-effector is a cabin to which different tools can be mounted. Different operations can be performed by changing either the tools mounted to the end-effector's cabin or by changing the cabin itself.

The end-effector cabin is an exchangeable control cabin and tool carrier, positioned and orientated by the robotic OM, to which robotic tools such as a tool for positioning and bolting can be mounted. Further tools can be developed and attached to the cabin (e.g. welding). In addition to the development of tools to be attached, new end-effector cabins for can also be developed, for purposes such as component positioning or inspection.

System Variations: In terms of efficiency, the robotic crane is not the best option. Also, after the construction factory climbs the secondary work cannot benefit from it. This means that there are two solutions for the developers of the system: to complete the work floor-by-floor (one sequence for each floor) or to find another way to deliver the materials to the levels below. One solution is to completely remove the robotic tower crane and replace it with a lift platform capable of delivering both to the construction factory and the levels below; in this case the constructors will be able to have parallel activities.

The system was designed for tower buildings with a central core. It therefore allows small variations to the core, and in terms of building typology there isn't so much flexibility.

ROD: The beam components are designed on basis of ROD to be guided into place automatically. The tower crane places them into position and the bolting end-effector connects the components together. The beam components are split into: lateral parts connected with the columns and junctions or intersections (cross-like shape) linking the lateral parts in two directions.

5.2.4 Ground Factory (fixed location, vertically oriented building) and Building Push-up

Systems in this category are characterized by the installation of a fixed, ground-based, on-site factory for the erection of vertically oriented buildings. The main factory is located in the ground floors where the building's main structure (columns, beams, structural walls) is assembled. Both systems in this category therefore utilise a rail-guided robot system on the ground, which picks up components from delivery trucks, storage or the on-site sub-factory and positions them. The push-up is accomplished by hydraulic presses. After the push-up, the interior finishing on the upper floors is accomplished in parallel to the assembly of the main structure on the ground floor. The push-up mechanism simplifies assembly operation and logistical efforts as it allows major work to be done on the ground floor. Furthermore, the pushed up building provides a factory roof, taking away the need for a complex roof structure. However, due to a loading-bearing capacity limitation, the height of the buildings that can be assembled is limited and it is not possible to construct super-high-rise buildings using the push-up mechanism.

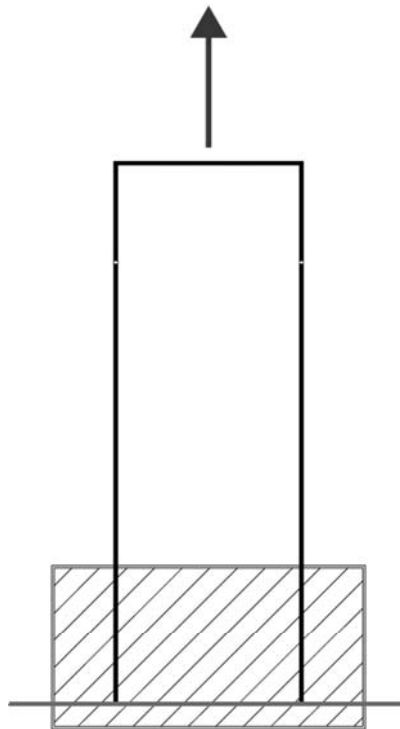

System Name	Company
13 Automatic Up-Rising Construction by Advanced Technique (AMURAD)	Kajima

Automatic Up-Rising Construction by Advanced Technique (AMURAD)

Company: Kajima Corporation, Japan

Category: GF (fixed location, vertically oriented building) and building push-up



GF / rail-guided manipulators

Evolution Scheme: In the case of the AMURAD, the building is assembled on the ground floor and pushed up floor-by-floor by screw presses. Firstly, the screw presses and the rails required for the rail-guided, ground-based robots (Z-Cary main system) transporting and positioning prefabricated concrete components are installed. Then the GF structure covering all operations is erected.

Elevation: The elevation shows the interplay of component positioning on the ground, the factory structure covering the lower floors in which the building is sealed, and the interior finishing work on the higher floors. Work is done on five levels in parallel; within these five working levels the building is completely finished. The first 3 levels are covered and enclosed by the factory structure. A representation of the work that could simultaneously take place over five floors in parallel can be seen below:

- Ground Level (1st floor): assembly of main structural components
- 2nd level: assembly of facade and balcony elements
- 3rd level: finishing and sealing of facade
- 4th level: installation of interior walls, plumbing, appliances, toilets etc.
- 5th level: final finishing, such as painting etc.

Ground Plan: The ground plan shows the interplay of the rail-guided robot systems, the column grid and the push-up mechanism on the ground level. Each column is assigned a push-up mechanism. The beams span the whole width of the building. The components processed are reinforced concrete components (main elements of the kit: columns, beams, floor slabs, facade elements, balcony elements). The joints between the elements are fixed with concrete on the ground level on-site. The push-up mechanism is so smooth and precise that the push-up does not affect the hardening process.

Subsystems: The AMURAD manufacturing the building on-site consists of many integrated subsystems:

1. **GF Structure:** The GF structure provides a covered and structured work environment for the first three floors. Within these three floors, the main structure, facade elements and balcony elements are assembled, and the building is sealed. Furthermore, the factory structure provides working platforms for facade work as well as a frame in which a VDS can be installed.
2. **Push-up Mechanism (referred to by Kajima as Z-Up system):** A screw press is installed under each column. The screw press functions as jig/fixture which guides the column positioned by the Z-Cary main robot into place. Additionally, after positioning, alignment and fixation of all the columns and beams on the ground level, the screw press smoothly and precisely pushes up the building so that the next floor can be erected on ground level.
3. **Rail-guided Ground-based Main Robot (referred to by Kajima as Z-Cary main system):** A rail system is employed on the ground level for the picking up and positioning of columns, beams and floor slabs by a robot. The robot has 4 DOFs

(Translation on rails lengthwise, translation sideways, rotation, lowering/lifting of components). It can be equipped with component-adjusted end-effectors with additional DOFs (e.g. a floor slab installation end-effector adds an additional DOF).

4. **Rail-guided Ground-based Horizontal Logistics Assistant Robots (referred to by Kajima as Z-Cary subsystem):** On the ground, a rail system for two horizontal logistics robot is installed flanking the main robot on both sides. The two robots transport beam elements and floor slabs into the factory and supply the main robot. The main robot can thus stay in the factory and does not have to go back and forth to pick-up components, thus eliminating waste. Time-consuming activities that do not add any value are also reduced.
5. **MHSPY (optional):** A MHSPY can be erected on the ground level into which rail-guided Main Robot and horizontal logistics assistant robots can drive. An overhead crane positions components onto the robot systems.
6. **VDS (referred to by Kajima as Mighty Hand):** A rail-guided robot delivers (within the GF structure) material to the 2nd and 3rd floor for interior finishing. The robot system can also deliver loaded mobile and immobile parts pallets as a mechanism that allows the material to remain balanced in an upright position during transport. The robot can rotate its final link, on which the material or roll car is positioned, and position it on the 2nd and 3rd floors in a way that is easy to deliver delivery or pick up by workers.
7. **Balcony Positioning System:** A balcony position system works on a rail system on the 3rd floor of the factory structure, transporting and positioning prefabricated balcony components.
8. **On-site Component Storage and MHSP (optional):** Apart from the GF, sub-factories can be erected which can function as storage for the on-site factory and as covered processing yard for the structured on-site transformation of low-level into high-level components. The VDS can be used to transport material/components JIT to the 2nd and 3rd floors via a rail system which extends into the sub-factory.
9. **RTMMS:** Data from sensor systems as well as from the servomotors/encoders can be read in order to control equipment operation and to monitor the component assembly process.

End-effectors: The above described subsystems can be equipped with various end-effectors to suit the picking up, positioning and adjusting of various component types. The speciality of the AMURAD is that the main manipulating system (Z-Cary) not only works with component adjusted end-effectors, but various other subsystems:

1. End-effector for pickup, positioning of columns and beams (Z-Carry main system end-effector)
2. End-effector fixture in which the column is positioned and the automatically adjusted (Z-Up End-effector)

3. End-effector for transport of beams (Z-Carry subsystem end-effector)
4. End-effector for transport of floor slabs (Z-Carry subsystem end-effector)
5. End-effector for pickup, positioning of floor slabs (Z-Carry main system end-effector)
6. End-effector for delivering roll-cars with materials for interior finishing to the 2nd/3rd floors (Mighty Hand end-effector)
7. End-effector for positioning of balcony elements (End-effector of balcony positioning system)

System Variations: The size of the building can be varied lengthwise as long as the column grid structure is synchronized with the positioning of the push-up mechanisms. The minimum width depends on the accessibility by the rail-guided main and sub robots, and the maximum width on the ability of the beam elements to span the distance. Basically, the arrangement of the components should follow an orthogonal arrangement. However, the columns at the end of each front side can be irregularly arranged, and the rail system can also follow a curve. Furthermore, components can be created from parts and low-level components off-site or on-site in a sub-factory.

Another scenario envisioned by Kajima was for the system to be used to enhance existing buildings or to integrate damping systems (on the ground level) into existing buildings. To achieve this, the screw presses are installed directly next to existing columns; the building is cut at the ground level and pushed up by the screw presses' end-effectors. From then on the above described process of lifting and component (or damping system) installation on ground level can start.

ROD: Columns are designed in a t-shape to ensure the efficiency of the rail-guided main robot and its end-effectors. When considering the beam and floor slab components, the dimensions and potential weight of the main robot is taken into account. On a building and urban level the orientation of the building and thus the main drive-in entrance for the main robot system has to be considered in the planning phase. It also has to be considered whether optional sub-factories could be installed on the long side of the building.

5.2.5 Ground Factory (fixed location, horizontally oriented building) and Building Push-up

Systems in this category are characterized by the installation of a fixed, ground-based on-site factory for the erection of horizontally oriented buildings that are long and/or wide horizontally, while at the same time relatively flat. Skanska, unlike Kajima, developed its system not for the construction of vertically oriented buildings, but for horizontally oriented condominiums. Also, in terms of component size and complexity, it takes a different approach. While the positioning robot of the AMURAD system processes a multitude of smaller and lighter components, Skanska's positioning robot processes a smaller amount of larger and heavier wall elements. A similarity between AMURAD system and System Skanska is the installation of a ground-based, rail-guided, robot system.

Sekisui Heim's J-Up system could also be placed in this category. The J-Up system (so far) only automates the Push-up mechanism. The assembly of the prefabricated panels on the ground level, as well as the interior finishing, are done manually. The system allows hydraulic jacks to be placed freely, and a complex rail system to guide robots is not needed. The system thus allows for a high degree of flexibility in terms of the layout and shape of the building, as well as in particular its horizontal extension. Due to the characteristic of combining automated systems with manual work in parallel to hybrid systems, relations to other categories exists (centralized SF in combination with conventional construction; decentralized SF in combination with conventional construction).

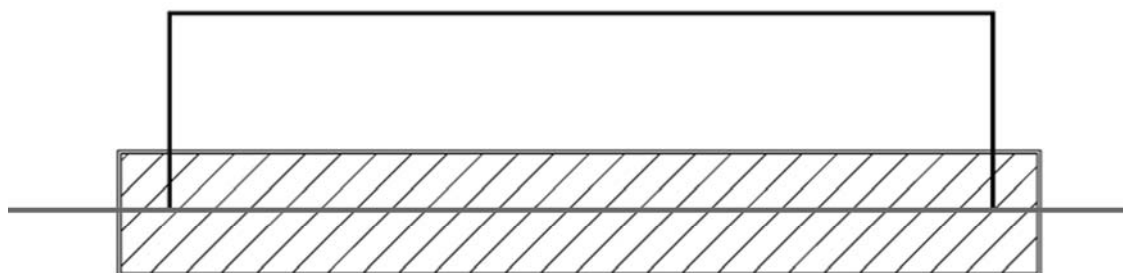

System Name	Company
14 System Skanska	Skanska
15 J-UP	Sekisui House

However, due to the location and working-direction oriented focus of this categorization, the system was allocated to this category (GF - fixed location, horizontally oriented building

- and building push-up). In contrast to other systems in this and the preceding category, the J-Up is a relatively low cost system and thus lowers the barrier-to-entry. It was used by Sekisui House itself as well as by sub-contractors who did the on-site assembly work. The push-up methods developed (especially those simpler ones of J-Up and System Skanska, but also the AMURAD from former category) follow the traditional construction of timber buildings in Japan where the complex roof structure is constructed first on the ground and then pushed up, providing a shelter for completion of the building.

System Skanska

Company: Skanska Group, Sweden

Category: GF (fixed location, horizontally oriented building) and building push-up



GF, HDS (rail-guided manipulator)

Evolution Scheme: Swedish construction service group Skanska has developed a new construction robot for housing construction. Constructing a house on the ground is dependent on weather conditions, and to do so without scaffold and cranes is the innovative idea Skanska has tasted in a full trial with its new construction robot that can lift 12 to 14 tons with millimetre precision. The robot assembles building elements and lifts heavy parts up from the ground to the next level. The advantages of this method are a reduced construction time, lower costs, easier planning and a safer working environment. The evolution sequence for this construction system is as follows:

1. Top floor assembly on the ground
2. Push the top floor up
3. Secondary top floor assembly
4. Repeat this process as required
5. Complete building

Skanska has applied modularization strategies to the building-component system:

- 80% standardized concrete components that can be handled by the HDS on the ground with a reduced level of complexity.
- Components 20% customized by Skanska to each project (according to Skanska this is sufficient to deliver a high-value unique product to the customer at a reasonable cost)

Elevation: The positioning and alignment of the structural main elements (concrete components) is done on the ground floor by the ground-based HDS. Further work is done in parallel on the ground floor and upper floors. The detailed work process sequence can be described as follows:

1. FEL (transport of components to the site)
2. Use of unloading system for unloading wall components from the truck delivering those to the site
3. Temporary storage of the wall components
4. Assembly robotic system collects the wall components from temporary storage and carries them to the on-site factory;
5. Top floor assembly on ground
6. Pushing up of the first floor
7. Repeat this process again and again until the completion of the building

Ground Plan: At first, the site for the building is divided into grids based on the structural design. A guiding rail is then installed for the movement of the assembly robot within the grid. Then the pushing up system, with a temporary steel structure and heavy lifting hydraulic cylinders, is placed on the grid. The planning for the material handling mechanism and material stocks near the on-site factory is then done. This completes the on-site factory. Space is planned for the logistics on the ground. After completing the on-site factory, the construction begins with the top floor construction on the ground. After completion of the top floor, it is pushed up one level by the pushing up mechanism and the

assembly robot begins to construct the second highest floor on ground. After completing the second highest floor, like with the top floor, this too is pushed up (together with the top floor), continuing the process until the building has been finished. After finishing the construction of the building, the construction mechanisms are disassembled and the building is prepared for use.

Subsystems: Skanska's integrated automated building construction site, consists of many integrated subsystems:

1. **GF:** Steel structures and lifters are used as temporary load bearing structures during the construction of the building. After completion of the building, those are removed. The GF structure can optionally be covered, thus creating a weather-protected work environment.
2. **Lifting System:** After completion of a floor on the ground, heavy-duty hydraulic cylinders are used to push the whole floor up onto the temporary load bearing structures.
3. **Ground Based HDS (rail-guided assembly robot):** Picking up the modules and then delivering them to the construction area where they are integrated into the building. The system is able to position and orientate components.
4. **Ground Based MHSPY (optional):** A rail mounted overhead gantry crane can be installed for the unloading of concrete components from trucks delivering them to the site.
5. **Material Unloading Automated System (optional):** An automated material unloading system is used to unload the modules/components from the truck delivering them to the site.
6. **Controlling Systems:** This lifting process must be very strictly controlled and thus the hydraulic cylinders are fitted with an internal position transducer. Similarly, the pressure lines have pressure transducers, all being located internally such that they are protected from inclement weather, dirt, humidity, etc. All the information is received at a control panel, which, by means of a Programmable Logic Controller (PLC), manages the data and sends orders to the electro valves.
7. **Programmable Logic Controller (PLC) system:** The aim of using a PLC is to keep the synchronisation of the hydraulic cylinders. A PLC, or programmable controller, is a computer used for the automation of electro mechanical processes, such as the controlling of machinery on factory assembling lines and pressure sensing. PLCs are used in many industries and machines. Unlike general purpose computers, a PLC is designed for multiple inputs and output arrangements, extended temperature ranges, immunity to electrical noise, and resistance to vibration and impact. A control panel allows the operators to be constantly aware of the load and position of each of the cylinders, and they can stop the lifting procedure if any of the system variables exceeds

the maximum defined thresholds. In addition, there are oil level and temperature monitors and alarms that stop the procedure should there be any unforeseen circumstance, such as a pressure drop.

8. **Supply System:** Various precast concrete prefabrication plants operated by Skanska can be integrated with the management and control system, and can deliver components JIT, JIS to the site.

End-effectors: Ground based HDS (rail-guided assembly robot) can be equipped with various end-effectors, necessary for picking up concrete components. Due to the high-degree of standardization of the concrete components, so far only one end-effector has been required. However, if greater variety is required, additional exchangeable end-effectors can be developed.

System Variations: Due to the modular approach followed by Skanska, the following variations to the system are possible:

- **Using more than one assembly robot:** During the construction process of one building, generally one assembly robot system is used. However, if two are used for small buildings from both sides and more for bigger buildings, then the time required can be reduced and an even more efficient construction procedure can be achieved.
- **Parallel construction in more than one bay:** Generally this system has a single bay construction procedure, meaning two columns in both sides of the building. In such a case it is not possible to make the building wider if needed. However, by using two bays with one column in center of the construction site, as well as one assembly robotic system on each bay, wider buildings can be made. More than two bays could even be used, with assembly robots in each bay to build wider than normal buildings, like hospitals, schools etc.
- **Simultaneous multiple site constructions:** Generally, this system is used for a single site construction, meaning a set of construction systems used for the construction of one building only. However, this construction system can also be used for constructing multiple buildings at the same time by creating a single permanent storehouse for the construction systems.
- **Improving the capability of lifting cylinder:** Heavy lifting cylinders with a capacity of 12 to 14 tons are generally used. The capacity of the lifting cylinders can be improved upon, so that buildings higher than six storeys can be made. .

ROD: On a component level, ROD is employed in the modular level design concepts for building components and construction processes. Component level designs are of the wall, floor and roof structure as well as toilet modules, kitchen modules, vertical circulation cores, office modules, storage modules etc. On a building level, the expansion of a single module to a whole apartment, based on all the facilities needed for an apartment, can lead to a larger building design when ROD is applied. On an urban level, Grid-based modular planning for the building can expand the possibilities of extension of the building as well as the flexibility of the design on an urban level. This process of design has the flexibility of

being able to use every grid of the design as the user requires, it also offers the possibility of building in a simple and easy way with the one system (like System Skanska) for construction. It is called the modularity in design process. Modular design with simple grid system planning gives the city a cityscape that is both linear and pleasing on the eye.

J-Up

Company: Sekisui House, Ltd., Japan

Category: GF (fixed location, horizontally oriented building) and building push-up



Hydraulic jacks lift up finished floors and allow convenient assembly of the factory prefabricated elements on the ground

Evolution Scheme: The basic concept of the method is to build the upper floor first, and then finish the lower floor. In Sekisui House, they use hydraulic jacks to make the concept possible. To meet the requirements of rapid construction in Japan, Sekisui House prefabricates all elements in the factory. In this way the method works safer and faster. Firstly, the hydraulic jacks are located on the finished foundation and roof is assembled directly while on them. Secondly, the jacks lift the roof up and the workers finish assembling walls of the 2nd floor. Thirdly, the jacks lift the finished 2nd floor up, and the workers finish assembling the walls and 1st floor. Finally, workers finish the interior fittings and the house is ready for moving-in.

Elevation: At first, the foundation is prepared. J-Up hydraulic jacks are positioned as dictated by force analysis software, which is based on the floor plan layout. Then, the roof and floor beams are assembled; special supporting steel frames are put in place under roof and over the foundation in case of earthquake during the lifting up period. This is the first period of lifting up and stilts segments are inserted in the middle of the jacks. The cylinders then descent back to their initial position. After this, the second period of lifting up happens and stilts segments are inserted into the middle of the jacks. Again the cylinders descend back to their initial position and the third period of lifting up commences. The prefabricated steel frames between the roof and floor beams are then assembled, the special supporting frames are replaced with normal frames, and assembly of the insulation and facade is finished. At this stage the 2nd floor is finished.

The special supporting steel frames are positioned under the finished 2nd floor and fixed to the foundation so that in case of an earthquake during the building does not collapse during the assembly process. The fourth period of lifting up with the floor beams is commenced and stilts segments are once again inserted into the middle of the jacks before the cylinders descend back to their initial position. The fifth period of lifting up with the floor beams is then undertaken, stilts segments are inserted in the middle of the jacks, and the cylinders descend back to their initial position. Finally, the sixth period of lifting up with floor beams takes place. The special supporting frames are replaced with normal frames and the assembly insulation and facade is finished. The 1st floor is finished, and thus so is the building.

Ground Plan: J-Up hydraulic jacks are located at fixed positions determined by force analysis software, which is based on the floor plan layout. Principally, they use 6 to 12 jacks on one site. The J-Up jack is a twin-cylinder hydraulic jack whose maximum load is 4 tons. The lifting speed of the jack is 900mm in approximately 4 minutes 30 seconds. With the help of J-Up jacks, the largest floor area that can be constructed is 256m² and two floors at most.

Subsystems: The J-Up (system) consists of many integrated subsystems:

1. **Rolling Mills:** Rolling Mills are used for metal forming in order to obtain 3.2mm thick steel sheets. The bare steel sheets pass through a group of (13) rolling mills. As an

automatic process, a rolling mill is also integrated with measuring device, so that the process is more effective and human labor is not necessary.

2. **Coiler:** A coiler is used for coiling the steel sheet. In the factory, steel sheets are coiled in order to save space, and to be convenient for transportation.
3. **Drilling Machine:** Steel sheets are slid into the drilling machine. The drilling machine drills a few holes according to the designed position. Through these holes, adjacent frames can be screwed up together.
4. **C-shaped Machine:** To obtain more strength, a C-shaped steel frame is a good solution. At the same time, a C-shaped configuration helps to store raw material.
5. **Feeding Table:** A placing robot picks up a single element onto the feeding table. The sliding table can then slide into the welding zone for welding. Different sized frameworks can fit the table.
6. **Coating Tank:** Due to the high humidity in Japan, frameworks need to be coated after being welded together. In Sekisui House, framework coating in a coating tank consists of two processes: phosphate plumber treatment and electroplating coating.
7. **Hydraulic Jacks:** Computer controlled jacks are used to push up the building. Stilts segments are inserted into the jacks during the pushing up process to extend the push-up stilts on which the upper part of the building is temporarily resting.
8. **Supporting Steel Frames:** Special supporting steel frames are positioned temporarily under the finished and pushed up floors and are fixed on the foundation so that a collapse of the building in case of an earthquake is prevented.

End-effectors:

1. **Placing Robot Gripper:** The end effector of the placing robot is a four-fingered gripper, which has only one DOF. But it is enough for picking up the steel and locating it at the right position.
2. **Welding Robot:** The end-effector of the welding robot is a welding gun linked to a welding drum.
3. **Stacker Crane Shovel:** The end effector of stacker crane in an automated warehouse is a shovel that can translate on a series of rollers. It is bi-directional both horizontally and vertically. It is remote controlled by workers on the ground.

System Variations: The system is able to erect any building based on Sekisui House steel frames. The number of jacks can be varied depending on the size and shape of the building.

ROD:

- **Placing Robot:** Placing robots are used to pick up steel elements and place them at the correct position on the feeding table.
- **Welding Robot:** There are two welding robots in each welding zone. These robots weld the steel profiles together into finished steel frames, and they are preprogrammed to cooperate with feeding tables.
- **Stacker Crane:** In the automated warehouse, components are piled up on shelves. A kind of bidirectional stacker crane is applied between two shelves. It has 3 DOFs and is based on a pair of tracks located on the floor and ceiling. In this way, components can be piled compactly to store more in limited space.

5.2.6 Off- and On-site Combined Factory (both in a fixed location)

Systems in this category are characterized by the close cooperation of an off-site factory and an on-site factory, both of which are operated by the building manufacturer. The on-site factory is a modular and temporary hall structure completely independent from the building. It encompasses the building completely and is self-supporting. The components delivered to the site are high-level components and delivery and installation are organized strictly JIT and JIS. The temporary on-site hall provides a sealed and heated work environment as well as an overhead crane system. From 2005 to 2007 NCC ran a test project for a system falling under this category: NCC Komplett. The NCC Komplett system was a manufacturing system fully integrating factory prefabrication with a mobile on-site assembly hall. In the fixed off-site factory, concrete walls were customized according to the architect's plans, and even installations such as windows, doors and radiators were integrated. In the factory, the high-level wall and ceiling components were completely pre-installed and finished, which meant that even furniture (e.g. kitchen) and electrical installations, switches, light systems and radiators were pre-installed. The completed modules left the factory and were transported to the construction site, JIT and JIS. The final assembly took place in a temporary, mobile, and heated assembly hall. Four assembly workers and one assembly foreman were needed per building. All production was performed indoors, either in the factory or in the mobile assembly hall. The factory was clean, and the components were handled by workers wearing gloves to protect the finished modules.

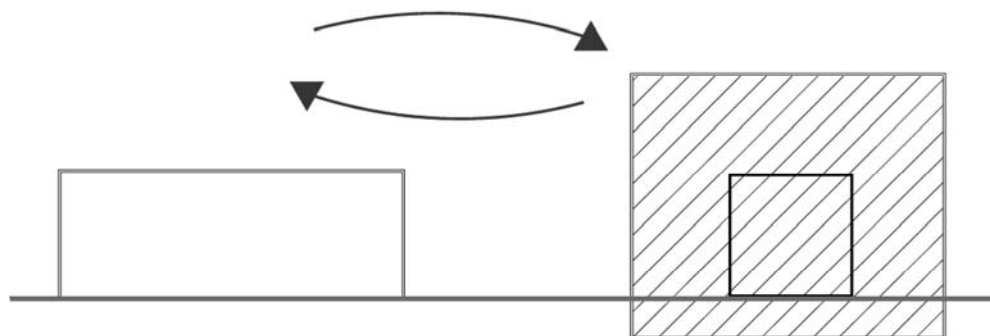

	System Name	Company
16	NCC-Komplett	NCC

NCC Komplet

Company: NCC, Sweden

Category: Off- and on-site combined factory (both in a fixed location)



On-site factory (NCC, 2012)

Evolution Scheme: From 2002, NCC Sweden began working on developing an industrialized concept for multi-storey residential buildings and, in accordance with this concept, from 2005 to 2007 it ran a test project called NCC Komplet. NCC Komplet TM (NCC Complete) is a way of building homes in apartment blocks. The system halved the construction time, enhanced quality and reduced costs, while giving the architect considerable latitude in terms of satisfying customer requirements. About 60 operators worked in the factory in accordance with a rotating time schedule. All production was order controlled. Purchases were conducted directly from the Manufacturer, without intermediaries. The degree of automation was high. Incoming and outgoing deliveries complied with the JIT principle. The company's own concrete plant guaranteed the quality of the high performance concrete that was required. The factory had an annual capacity of at least 1,000 apartments, meaning that one operator could manufacture 17 apartments per year. The working environment in the factory was clean and tidy, as was final assembly, in order to assure the quality of the finished surfaces. The components left the factory as flat packages, and in certain cases in specially designed trucks. During full production, a truck would leave the factory every 15 minutes.

- **Walls:** Each wall was customized in accordance with the architect's blueprints. Following reinforcement and the placement of, for example, electrical installations, the walls were cast using high-performance concrete. After curing, the windows, doors and radiators were assembled. Subsequently, the wall was sent for wallpapering and was equipped with electricity switches and power sockets. The completely finished wall would then proceed to delivery.
- **Ceilings and Floors:** Normally, one tenant's floor is another's ceiling. These buildings were produced in the form of double floor slabs with a lightweight framework, resulting in quiet buildings. Parquet flooring was the standard, but other materials were conceivable. The bathrooms, which were also completely finished, had tiled floors. The ceilings were surface treated and, like the floors, were delivered in a fully complete state.
- **Kitchens:** Two kitchen varieties were available: I-kitchen and L-kitchen. The kitchens were fully installed already in the factory.

Elevation and Ground Plan: To protect the ready-manufactured building modules, and to be independent of seasonal conditions, the entire assembly process took place in a gigantic hall. Double canvasses provided a good working environment and a healthy climate. Overhead cranes took care of all lifting. As discussed above, the maximum building height was eight floors and the maximum length was 60 meters. The overhead crane was at the heart of the assembly process, lifting module after module into place. Five employees assembled three to five apartments per week. Key concepts were logistics and orderliness. The fitters wore gloves and shoe covers so as not to damage the finished surfaces. Before assembly, the basement or bottom slab was built in a conventional manner. After assembly, the facade was finished by rendering, for example.

Subsystems: Off- and on-site combined manufacturing systems consisted of many integrated subsystems:

1. **Off-site Component Factory:** The off-site factory prefabricated concrete elements which were equipped in the factory with all installations and finishing (cabling, windows, radiators, switches, kitchen and bath furniture/equipment).
2. **Component Transportation System:** A large number of transport trucks delivered the components JIT and JIS, from the factory to the site.
3. **On-site Factory Structure:** A temporary on-site steel structure covers the whole construction space, provided a weather-protected and SE and also a platform for the installation of OMs. The factory was self-supporting and rested on the ground. The factory structure also provided a weather-protected environment for excavation and basement work.
4. **On-site MHSPY:** A MHSPY was integrated into the on-site factory. Delivery trucks were able to drive directly into the factory and the material could be stored or picked up directly from the trucks by the OM system.
5. **OM System:** In the interior of the factory large overhead rail-guided manipulators operated. They were mounted to the factory structure.
6. **Material Flow Management System:** NCC Kompletz fully integrated demand oriented off site manufacturing with the on-site factory. Components were delivered from the factory to the site JIT and JIS. All input materials came directly from material manufacturers. IT-based systems were used for fault-free project planning. Using state-of-the-art 3-D software, architects created buildings with unique characteristics and design. NCC's own concrete plant guaranteed the quality of the required high-performance concrete.

End-Effectors: NCC Kompletz integrated various end-effectors off-site and on-site:

1. **Concrete distribution:** This machine distributed the concrete in a uniform way, safely and clean. Hanging from a parallel crane, the machine was placed on top of the formwork and delivered its contents from the top. The form work shakes to distribute the concrete and after some hours the concrete panel is complete, dry and ready to work on.
2. **Manual Vacuum Gripper:** The manual vacuum gripper helped workers to grip panels and flat parts easily. It was used only for light work, since the automatic vacuum gripper takes care of the heavy work.
3. **Vacuum Robot:** The vacuum robot was a robot attached to the ceiling by a spring. Together with the vacuum gripper, it allowed workers to carry heavy panels. This tool was especially useful due to the modularity of the system.
4. **Vacuum Gripper:** The gripper worked through suction; it held the material without damaging the surface.
5. **Hovercraft Platform:** This platform allowed workers to move the walls along the factory. Under the platforms pressure, air flows to reduce the friction. The walls, units and modules were thus easier to move.

System Variations: Due to the SF structure, the maximum building height was eight floors under this system, the longest being 60 meters long.

ROD:

On component level ROD was applied to modularize the building into as less high-level components as possible. Thus complex work tasks (including the equipping of the concrete components with cables, radiators, finishing and furniture) were in majority shifted to the factory reducing work task variety and complexity on the construction site. With this design approach the basis for the deployment of a structured on site factory environment was laid. Furthermore, in order to allow the application of the on-site factory, on building level the design had to consider that the building can be assembled within the factory leading to separate condominium blocks instead of condominium rows. This design necessity also influenced the arrangement of the buildings on an urban level.

5.2.7 Self-supported Ground Factory (horizontally moving)

Systems in this category are used more for the assembly of horizontally oriented buildings than for vertically oriented high-rise buildings. Systems in this category are therefore characterized by a self-supporting GF, which completely encompasses the building. The factory moves on rails along the horizontal main direction of the building, subsequently allowing the completion of the building in a horizontal direction. Both systems assigned to this category are mechanized rather than automated systems that can be more considered as historical prototypes than as automated construction sites. However, they were considered for analysis in this chapter and for being integrated into the categorization systems, as the approach, especially for Europe (where buildings are in most cases horizontally oriented), is highly relevant. The author of this thesis sees a high potential to deploy such systems quickly and cost efficiently by utilizing the latest automation and robot technology.

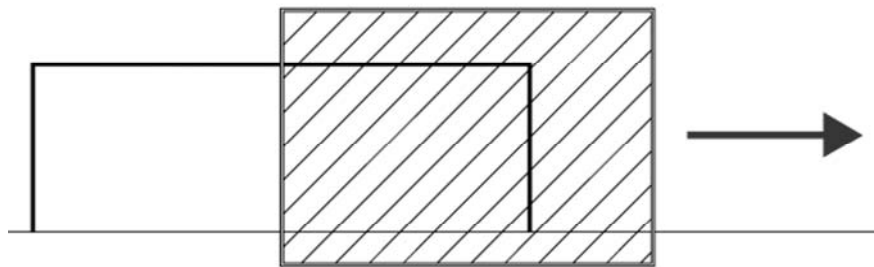

	System Name	Company
17	Bauhelling	AHAG-Sommerfeld
18	Bauschiff	Neufert

***Bauhelling* Summerfield**

Company: AHAG-Sommerfeld, Germany

Category: Self-supported GF (horizontally moving)

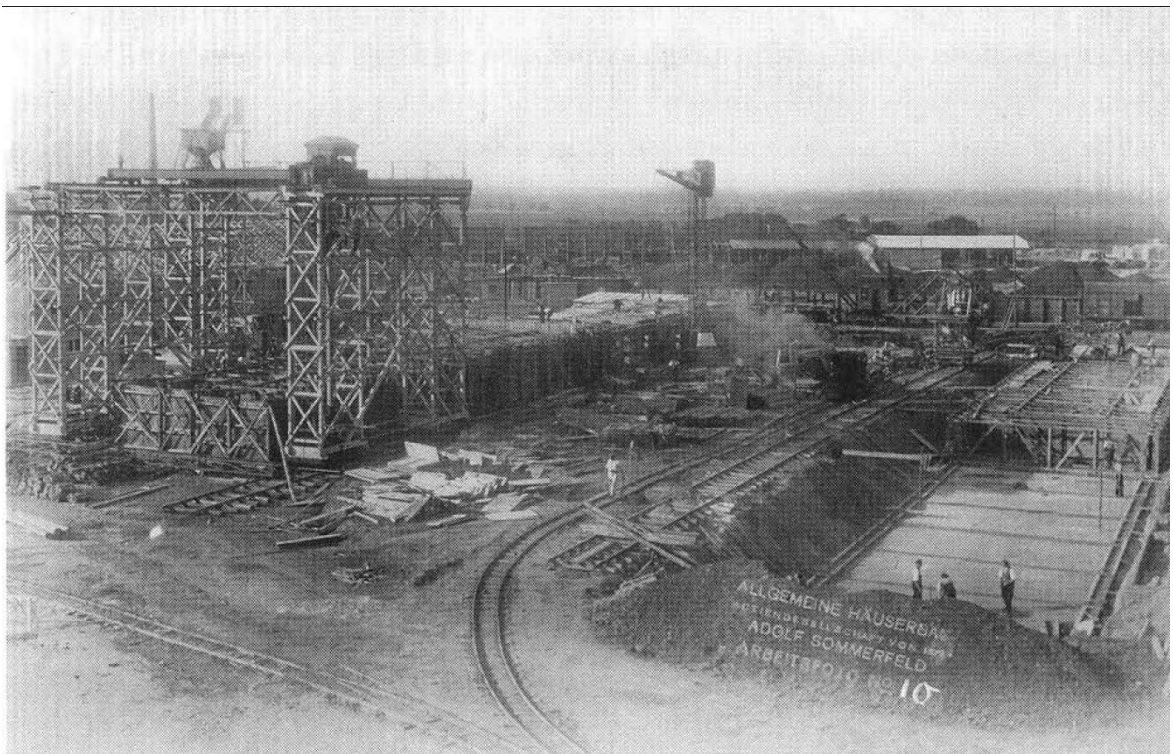

Set up of factory and logistic system on-site (Kress, 2011, p. 171/ Picture Documentation by AGAG-Sommerfeld, Schild)

Evolution Scheme: Sommerfeld's *Bauhelling*, which provides the possibility of operating multiple cranes in parallel, was inspired by Harland & Wolff's shipbuilding yard, which constructed the Titanic in 1913 (see also 3.3.2). Adolf Sommerfeld introduced the *Bauhelling* system in the 1920's - initially inspired by shipyard construction (*Bauschiffe* in German). Sommerfeld's system consists of scaffold, within which the buildings were constructed, an elevator, which serves for carrying materials and components to the upper levels, a set of four tracks (two horizontal tracks and two vertical ones) for transportation, a concrete mixer lifted by the elevator and also a hook crane and a concrete pouring machine, which move along the tracks in order to reach the desired positions. Before the construction process starts, a set of tracks is installed for the logistics of the system. These tracks are used for the transportation of components and equipment on-site, and also of for moving the field factory on the site. This way the tracks can be used not only for the construction of an individual building, but for the manufacturing of building blocks as well. The operation of the system starts with the installation of the field factory frame structure, integrating the HDS and end-effectors. While one HDS places the formwork for the first floor of the building, the second half of the field factory frame structure containing the elevator, the concrete mixer and the concrete pouring machine are installed. Afterwards, the field factory frame structure moves to the right and the machine pours concrete into the installed formwork, while the hook-crane prepares the next step. When a whole floor is complete, the process begins again for the upper floor. The building is thus erected layer-by-layer, starting with the ground floor.

Elevation: In the vertical section, almost all of the compartments of the system are visible. It may appear to closely resemble conventional scaffolding, however the transportation systems used in it are an innovative solution to achieve increased efficiency and reduce the amount of time spent in fulfilling the project. The field factory frame structure can be moved forward and backwards (guided by a temporarily installed on-site rail system) in order to complete the steps needed for the construction of an entire floor. It can then start over, repeating exactly the same steps before moving onto the following floor.

Ground Plan: Two parallel tracks run the length of the exterior of the building, while two more tracks (one carrying the hook-crane and the other the concrete pouring machine) are positioned over the building, spanning the gap between the two sets of tracks. On the track system, the field factory frame structure can be moved along the rail axis.

Subsystems: The Sommerfeld *Bauhelling* system consists of many integrated subsystems:

1. **Guiding rails (tracks):** A set of tracks is installed on-site to enable the system to not only move during the construction process, but also to enable the system to be transported and to continue working on the next building after the first has been completed.
2. **Field Factory Frame Structure:** A frame structure which can be moved on tracks and spans the whole building. The frame structure is a platform for the installation of

overhead cranes (HDS) and vertical lifts (VDS). Additionally, the frame structure can optionally be covered to provide a weatherproof work environment.

3. **VDS:** There is only one lifter attached to the scaffold. It looks like a tower and a concrete mixer is attached to it. Its function resembles that of a normal elevator, responsible for bringing concrete and other materials to higher levels.
4. **HDS:** Two overhead gantry cranes each span a section of the building and are able to move vertically in order to cover the whole workspace of the field factory frame structure. The overhead gantry crane has 3 DOFs (translation lengthwise, trolley hoist translation sideways, lower/lift of end link). Different end-effectors can be attached to the gantry crane (for example, crane hooks and concrete distributors).

End-Effectors:

1. A multipurpose hook end-effector is used for the transportation and placement of all the formwork needed for the construction of the building. It functions in parallel with the concrete pouring machine, installing all the equipment necessary for the next step.
2. A concrete pouring end-effector is used for taking the concrete from the concrete mixer and then moving along the tracks in order to pour concrete where it is needed. It is also able to move vertically, in particular to be lowered when needed for precision pouring in the lower levels during the construction process.

System Variations: The size of the scaffold remains the same for every possible building constructed by the system. However, it would be possible to have longer scaffolds to create longer buildings and to avoid moving the whole system back and forth too often. Another variation could be to have taller scaffolds, in order to be able to build buildings of different and even higher heights using the same system. The last possible variation of the system proposed by the author would be for the scaffold to have a wide span so that the system could also create wider buildings and not only buildings of a certain range of width.

ROD: On a component level the application of the system was supported by designing simple and rectangular shaped floor layouts. Those layouts allowed the use of the formwork system and guaranteed that the HDS could be used to position the formwork system properly. On a building level it was required that the buildings size does not exceed the space covered by the factory frame structure. On an urban level it is advantageous to design the building to be as long as possible so that the set up on-site factory can be utilized to construct not only a building block but a whole row or array of segments.

Bauschiff

Company: Neufert, Germany

Category: Self-supported GF (horizontally moving)

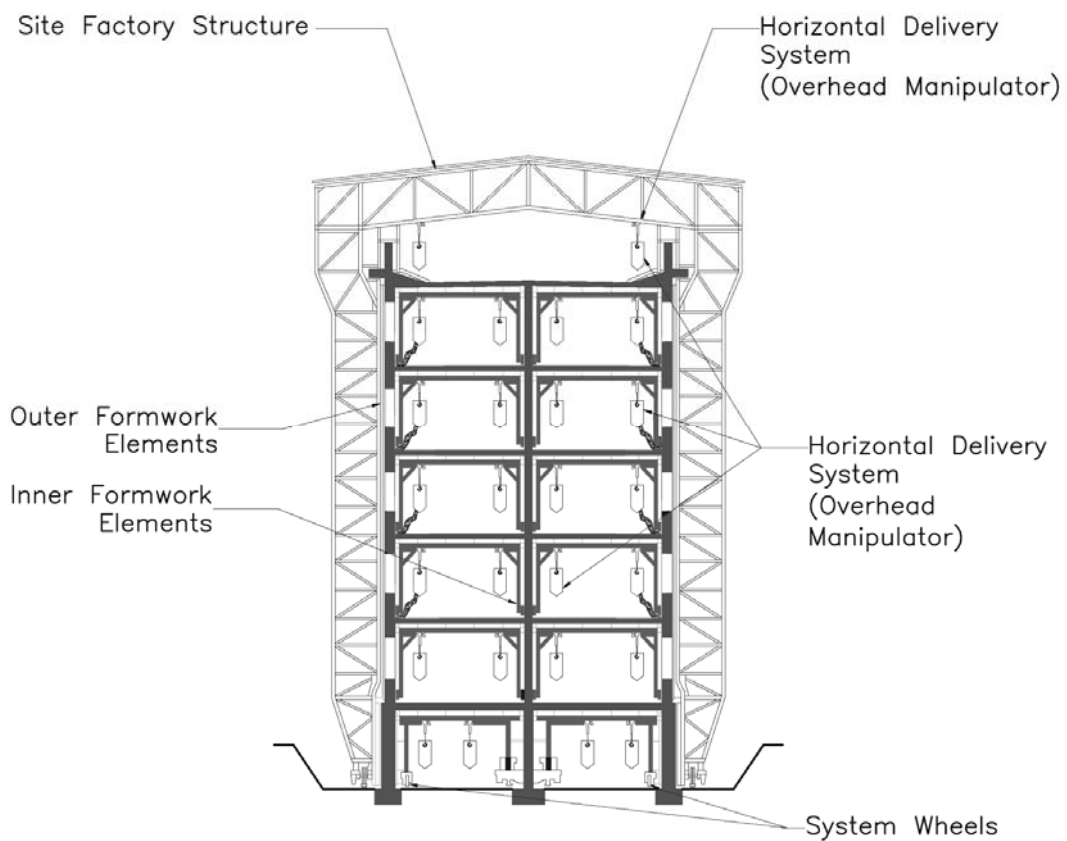

Horizontal building production by moving GF, vertical section (graphical representation on basis of **Neufert, 1943**)

Evolution Scheme: The Neufert's *Bauschiff* (literally translated, 'building ship') system consists of a moving weather-protected construction hall (system structure), the movable exterior and interior formwork segments, the materials elevator, as well as other various formwork elements (e.g. foldable roof formwork) and subsystems. The system rests on wheels and moves along tracks, producing linear concrete buildings. The building process starts with the preparation of the site. After the laying of the foundations, the construction hall is erected section by section, followed by the assembly of the exterior and interior formwork subsystems. When this is completed, construction of the building's interior can begin. No heavy machinery is needed for the assembly. Construction and concrete pouring always begins at the lower level and continues in a progressive manner. Concrete tanks are transported to each floor via the materials elevator. Once the hardening of the concrete is complete, the construction hall and the interior formwork are able to move along in the direction of the construction to begin work on the next part of the linear building. After the concreting in the first section of the building, the work on each level follows slightly behind the work on the level below. While the lower formwork elements are in place and the concrete is being poured, the formwork on the upper levels is being cleaned and covered in formwork oil. At the same time, finishing work continues in the interior of the building that has been left behind. Cleaning work, interior walls and installations are all done independently of the structural work that continues the length of the building. When the building is finished, the construction hall rolls to its next destination to start working on another building.

Elevation: The vertical section (the width of the building) shows the u-shaped steel frame segments of the system structure. The formwork placement begins floor-by-floor, starting with the basement. Once the placement is complete, the entire mold is realigned with millimeter accuracy through the use of measuring devices. The placement of reinforcements follows as well as the concrete pouring process. For a specific level, the concrete is poured from the floor above it, first for the walls, and then for the ceiling. The entire system rests on wheels, and moves along the tracks in order to create linear buildings. The construction hall encases the entire construction site, providing a weather-protected environment. As the system moves along, it uncovers only the finished parts of the roof. The formwork on each floor is able to move independently, starting from the basement and thereafter on the upper floors. Overhead tracks along this formwork frame allow the movement of materials to the desired destinations. Other work in the completed part of the building proceeds in parallel.

Ground Plan: The system structure (construction hall) rests on parallel lines of tracks. In its interior the exterior and interior formwork of the floor is in place, ready for the pouring of concrete to begin:

- Concrete mixer vehicles approach the open end of the construction hall and unload concrete into the concrete tanks, which then roll on tracks towards the material elevator. Once there, the tanks start ascending to the appropriate floor, where they stop automatically. Once there, a worker pulls them out onto the work platform to an overhead turntable, from which point they can be guided to the appropriate tracks in order to reach their destination.

- Concrete is poured into the formwork to become the walls of the lower floor. The pre-assembled steel reinforcement has already been placed on the floor of this level (ceiling of the lower level), but the concrete is poured after the lower walls are complete.
- The construction hall and work platform starts moving towards the next part of the building. All the formwork moves progressively, too, starting from the lower floors and moving on to the higher floors.

Subsystems: The Neufert's *Bauschiff* manufacturing of buildings on-site consists of many integrated subsystems:

1. **System wheels:** The construction hall (system structure) rests on wheels that move it along the building. The wheel mechanism allows for adjustments in height in order to address height differences between the building level and the neighbouring street, in order to avoid unnecessary excavations. The wheels are guided by a temporarily erected ground based rail system.
2. **Site Factory Structure:** The construction hall provides a weather-protected environment in the construction site. The main building process takes place within this hall until the roof of the specific building section is complete. The scaffolding is protected by a corrugated metal roof.
3. **VDS:** At the open end of the building, the material elevator is mainly used to transport concrete tanks to all the building levels. On the ground level, concrete mixer trucks fill the concrete tanks, which moved upwards via the elevator, and are removed by the workers on the working platform of each floor. The VDS delivers trolley hoists carrying concrete containers (concrete tanks) to the individual floors. On the individual floors the trolleys can be driven directly over to an overhead rail system.
4. **Interior Formwork Segment:** Its length is considerably longer than its width. Two of these elements are used on each floor, and move linearly and in parallel during the building process. The movement is performed via wheels moving on tracks.
5. **HDS:** The planning of the logistics and optimization of the building process are evident in the shipping process of the formwork components. In the factory, these components are loaded in the sequence they will be used during construction. After the double transfer from the wagon to the truck and from the truck to the site, the formwork components are ready to be used in the correct sequence. An overhead rail system allows trolley hoists to carry concrete containers (concrete tanks) on individual floors and thus to deliver the concrete to its final destination in manageable packages.

End-effectors:

1. **Concrete tanks:** The concrete tanks are transported by the elevator and stop automatically at the appropriate floor. A worker pulls them onto the connector rail so that they can roll to various processing places. In order to keep the lightweight and heavy concrete separate during processing, concreting boxes are used.

2. Scissor-gripper: A scissor gripper is used to lift elements in order to transport them and assist in their placement at the appropriate position.
3. Foldable roof formwork: It is the formwork used for the casting of the parapet walls on the roof of the building. This foldable formwork device is attached to the roof of the construction hall. It can easily be operated by one worker.

System Variations: The building hall size generally stays the same, and when fewer floors need to be built, its entire height is not utilized. However, it would be possible to have systems with frames of different sizes, either lower or higher. As in the case of the building height, building width was standard. However, if a row of buildings of smaller or larger widths needed to be produced, it would be possible to produce a system frame of a different size and achieve the desired results. The system structure produces linear buildings, but it is not limited to moving only in one straight line. The system is capable not only of moving perpendicularly to the building direction, but also of moving at an angle.

ROD: The window openings are integrated in the formwork used in this system. Due to the fact that the formwork moves at regular intervals, the resulting building designs consist of several repeating elements, both along each floor and on different floors. For example, it is evident that the windows all have the same size and are placed in a precise grid. Segments made of steel are placed on the ceiling formwork, under which the reinforcement passes through. There is enough space around the chair so that the ceiling's concrete can enclose the chair's sides. The chair's legs have a conical shape, which makes the future removal of the chair from the finished floor slab easy. From an urban perspective the system could be efficiently used to construct long, horizontally oriented rows of buildings or master plans with interrupted/uninterrupted long building blocks, orthogonally arranged along a horizontal axis.

The analysis and the graphical representation was done on basis of Neufert's original sketches, drawings and plans laid down in by Neufert in his book *Bauordnungslehre* (Neufert, 1943).

5.2.8 Sky Factory (moving upwards) for Simple Tower Manufacturing

Systems in this category manufacture simple (non-habitable) tower structures with a highly repetitive structure by using a factory which moves from bottom to top. In Japan in particular, there is a high need for such towers, which are used as advertisement towers, broadcast towers or sightseeing towers. Both systems in this category are simplified and altered versions of systems used for automated building construction. Systems in this category can, in contrast to other automated construction sites, be identified as line construction sites, as assembly is achieved by very closely following a vertical axis and because a high amount of like or similar components are assembled by a central manipulation system.

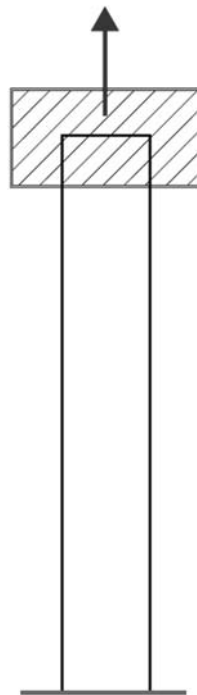

	System Name	Company
19	TS-Up	Taisei
20	Tower SMART	Shimizu

TS-Up

Company: Taisei Corporation, Japan

Category: SF (moving upwards) for simple tower manufacturing



SF

Evolution Scheme: Taisei uses the TS-Up to manufacture (non-inhabitable) towers for broadcasting and advertisement. The TS-Up makes the manufacturing of such towers weather immune, faster and prevents disturbance to the environment by construction. The system can be set up to construct a tower on top of an existing building, on the ground to construct a free standing tower, or a tower that is partly integrated as a servicing shaft into a building. A tower crane beside the tower positions the vertical structural main columns. Those are temporarily fixed into position and used as the structure along which a self-climbing two level OSF is lifted. The SF provides working platforms on the interior of the tower (which, during the positioning process, also function as fixtures for the guiding of prefabricated bracing elements into place) and working platforms on the outside for fixing and welding. The factory works along the vertical axis bi-directionally, as the factory is capable not only of climbing up the outside of the tower as it rises, but after preliminary completion can also climb down the structure. The step-by-step procedure of climbing down is used to weld joints to bracing elements at each level, and also to coat welded areas with alloy and paint. Additionally, during the operation of moving down, the upper platform of the SF can be used to assemble platforms to the tower.

Elevation: The elevation shows that work during the upwards rising process is done on three levels (the n th level, $n-1$, $n-2$). The n th floor is only at the very bottom part covered by the SF and the structural main columns are positioned on this level. On the $n-1$ level, the factory provides working platforms on the outside and inside of the building that function as fixtures during the guidance into place of prefabricated bracing elements during their insertion. On level $n-2$, the factory provides working platforms on the outside and inside of the building for fixation welding operations. Also on level $n-2$, the climbing mechanism is integrated into the factory and grips the tower structure. During the lifting of the factory from the top of the tower, the two working levels of the factory, and the multiple platforms, provide a safe working space for further fixation and coating.

Ground Plan: The tower crane, positioned besides the tower to be erected, has a large working space and allows the storage or delivery space to be located some distance from the tower (in contrast to Tower SMART, for example, where factory intake port requires material to be delivered directly to the ground of the tower). This simplifies the erection of towers in a confined space or on top of buildings.

Subsystems: The TS-Up manufacturing the building on-site consists of many integrated subsystems:

1. **SF Outer Stages:** The SF outer stages cover two segment levels that provide working platforms and integrate the climbing mechanism which raises/lowers it.
2. **SF Inner Stages:** The inner part of the SF (within the tower) consists of 24 vertical stages (every second level, with 6 working platforms per stage). They are lifted and lowered by the tower crane, which can reach the inner part of the SF from the top.

3. **Climbing Mechanism:** Four hydraulically actuated inchworm climbing mechanisms are positioned in the four corners of the tower. They climb up the structural main columns, which have been positioned, erected and fixed beforehand.
4. **V/HDS:** A tower crane is extended vertically during the erection of the tower. It is positioned right beside the tower and is mounted to the tower on every second level. The tower crane consists of segments and in order to be extended vertically new segments are added. The tower crane has a large working space and allows for the storage or delivery space to be located some distance from the tower.

End-effectors: The V/HDS uses simple (conventional crane-like) multipurpose end-effectors. The fixture guiding components into place in the interior of the tower can be seen as an end-effector as well.

System Variations: The TS-Up was developed on the basis of concepts and technologies of Teisei's T-Up. The system can be adjusted to towers which are similar in terms of the bearing structure, but which have, for example, different heights or distances between the vertical main columns. The system is currently only capable of processing steel components.

ROD: The tower is modularized into a kit which is adjusted to the needs and operational sequences of the TS-Up. The kit consists of:

- Vertical main structure column (height: exactly one SF level) with elements already fixed
- Horizontal beam elements
- Rectangular bracing elements
- Staircase elements and prefabricated platform elements

Tower-SMART

Company: Joint venture of Shimizu Corporation and NTT Facility Corporation, Ltd., Japan

Category: SF (moving upwards) for simple tower manufacturing



SF (Shimizu, 2013)

Evolution Scheme: Shimizu developed the Tower-SMART jointly with NTT Facility Corporation, Ltd. In order to construct broadcast towers all over Japan (small and medium sized towers, to support e.g. mobile phone networks) for NTT DoCoMo. The Tower-SMART makes the assembly of such towers weather immune and shortens the time necessary for construction by 20%. For the set-up of the Tower-SMART, the lower part of the tower (i.e. the first 5-10 meters) has to be built conventionally so that a stable and stiff base for the attachment of the CS is provided. The CS is able to grip these conventionally constructed and fixed columns from the outside and pushes up the factory. As the CS climbs up the outside of the tower (and does not sit on top of the columns), after the tower has been completed, the climbing mechanism can simply climb down the tower again and be disassembled at the ground level.

Elevation: A trolley manipulator can travel along two gantry cranes. The trolley manipulator travels to the smaller gantry crane to lift up steel components from the ground, and then travels over to the larger gantry crane, which spans the whole floor area of the tower. The steel components are high-level components, reducing the amount and complexity of assembly operations in the SF.

Ground Plan: The ground plan shows the interplay of the two gantry systems. The smaller one operates over the intake port and guides the trolley manipulator during component lifting. The larger of the two guides the trolley manipulator during the component positioning process. The SF within the cover provides reference points for the installation of the components as well as working platforms for the workers attaching welding robots and/or welding themselves.

Subsystems: The Tower-SMART manufacturing broadcast towers on-site consists of many integrated subsystems:

1. **Factory Roof Structure:** The SF completely covers the place where components are assembled on top of each other. On one of the four sides, the SF cantilevers over the floor area of the tower, generating a covered intake port through which material can be delivered. Rail-guided overhead systems can be fixed to the roof. The SF also provides working platforms on which workers can support the positioning, alignment and fixation process.
2. **SF Interior Working Platform:** The SF provides working platforms which allow column components to be conveniently positioned, aligned and fixed.
3. **SF Column Positioning Template:** The SF functions as a template for positioning of column components by providing reference structures in its interior.
4. **CS:** An inchworm-like and hydraulically actuated CS sits at the lower end of the factory. Upon the CS rest four round steel columns, which are the main structural elements of the SF. These four main columns are enclosed by a steel structure which is the basis for the cover, and it also provides the basis for the factory roof, factory floor and working

platforms to be mounted. The CS pushes the factory upwards along previously positioned and fixed column components.

5. **VDS:** On the factory roof, over the intake port, a gantry crane operates on which the trolley manipulator can travel and lift up components from the ground. The trolley manipulator and gantry crane together provide 3 DOFs (translation sideways by gantry crane, travelling of trolley manipulator along the gantry rail, lifting/lowering of end link). The end-effector adds additional DOFs to the system.
6. **HDS:** On the factory roof, above the floor area, a gantry crane operates on which the trolley manipulator can travel and position components. The trolley manipulator and gantry crane together provide 3 DOFs (translation sideways by gantry crane, travelling of trolley manipulator along the gantry rail, lifting/lowering of end link). The end-effector adds additional DOFs to the system for orientation the component.
7. **Welding Robot System (optional):** Welding robots can be used to fix the steel components to each other.

End-effectors: Since ROD reduces the complexity of the installation of high-level vertically orientated column elements, the need for various end-effectors is erased. The trolley hoist has an end-effector that holds the column during the lifting, positioning and adjusting processes by four ropes; each rope is attached to one of the four sides of the column, where small steel plates welded to the component provide gripping points.

System Variations: The system itself is based on concepts and technologies developed before for the SMART. Whereas in the SMART multiple trolley manipulators work in parallel, in the Tower-SMART only one trolley manipulator is used. Additionally, the design of the steel components according to ROD, and the resulting reduction in complexity in the SF goes a step further than in the SMART. From this perspective the Tower-SMART represents a simpler and less complex system.

ROD: As the Tower SMART is a Joint venture of the construction company (Shimizu) and the client (NTT DoCoMo), the design of the towers on a component, building and urban level can be fully adjusted to the capability of the Tower-SMART. The columns to be positioned are high-level components, which reduces complexity in the SF, and which are designed especially for installation by the system. The columns already have multiple beam elements fixed to them, so that the positioning of additional horizontal/beam elements is not necessary in the SF. The OM only needs to install the vertically oriented high-level components. The components at the bottom have steel clamps attached on all four sides which support the adjusting process. On a building or urban level, the applicability and efficiency of the Tower-SMART can be supported by synchronizing the location of the tower and the allocation of the Tower-SMART's SF intake port and its accessibility from below.

5.2.9 Centralized Sky Factory (moving upwards) in Combination with Conventional Construction

Systems in this category are characterized by the application of centralized SFs, which manufacture strategically important parts of the building. Around the centralized SF – in parallel – other parts of the building are constructed conventionally. However, the central SF – over the vertical logistic system – plays a major part in terms of material supply to the individual floors. Obayashi (see below) analyzed the efficiency of the location of the SF (identifying which parts were covered by conventional construction and which by SF) and proposed and deployed the system in various configurations. The system and its subsystems were based on the ABCS system allocated to the category “SF (moving upwards) supported by Building” (see 5.2.1). The Hybrid-ABCS can thus also be considered as a variation of ABCS.

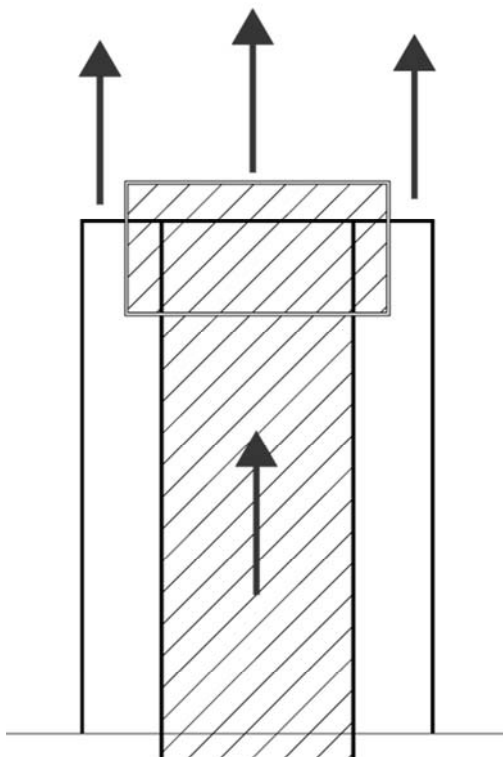

	System Name	Company
21	Hybrid-ABCS	Obayashi
22	Hybrid-SMART	Shimizu

Hybrid Automated Building Construction System (Hybrid ABCS)

Company: Obayashi Corporation, Japan

Category: Centralized SF (moving upwards) in combination with conventional construction



View of SF (Ikeda & Harada, 2006)

Evolution Scheme: The Hybrid ABCS is applied to buildings with a large floor area. In order to optimally use the capacity of the automated OMs, the SF is erected only over a strategically important area of the building (e.g. the core area of a building containing stair cases, elevators and major parts of the building technology). The floor area surrounding this strategically important area is erected in parallel, not by use of the OMs but by the use of rail-guided (optionally robotic) jib cranes, human labor and logistics support from the SF. As the assembly of structural components outside of the strategically important area over which the SF is erected is performed by using more human labor than in the main area, the system is called “hybrid” (automated construction and human based construction in parallel). The combination of both methods in one system turned out to be more efficient (see also 5.4, efficiency analysis) than the ABCS building which relied solely on automation. Consequently, parallelization of work in the core area and the surrounding area is indeed possible.

Elevation: The elevation shows that an ABCS SF with three OMs side by side is usually installed over the central area. A VDS (automatic lift) feeds the SF with material. The outer area is spanned by two rail-guided jib cranes, which are mounted to the top of the SF. As the outer area is not constructed automatically by the OMs, side covers enclosing the factory are not necessary, reducing factory set-up and factory disassembly time.

Ground Plan: The ground plan shows that the SF spans the core area of the building, as well as a side part. The allocation of the factory thus allows for the more complex core assembly part to be done or supported by the OMs, for an automatic lift to be installed and connected to the SF, and for the not so complex office areas surrounding the core to be erected in parallel by the more human based methods.

Subsystems: The Hybrid-ABCS manufacturing the building on-site consists of many integrated subsystems:

1. **SF Structure:** In order to optimally use the capacity of the automated OMs, the SF is erected only over a strategically important area of the building. The SF provides a platform for the attachment of the OMs, the rail-guided jib cranes and the CS.
2. **CS:** The factory rests and climbs on top of the building’s steel columns by hydraulically powered steel stilts which bear the weight of the roof, pushing it upwards floor by floor. Stilts are positioned over each column; statically, only every second of the steel stilts needs to bear the weight of the factory, and it is thus possible for every second of the stilts to be lifted to enable the manipulator to position a new column under it. The CS is not used as a physically active fixture allowing the self-adjusting of the component (like with FACES), but it at least guides the installation process by providing reference points for the AAMS.
3. **VDS:** An automatic lift delivers components (steel columns, steel beams, concrete floor slabs etc.) to the SF and to the OMs. The automatic lift is also used to supply surrounding area, via the SF, where the labor based method is applied.

4. **HDS (OMs):** 3 gantry type OMs, 4 DOFs (translation lengthwise, translation sideways, rotation, and lift/lower end link) with exchangeable component adjusted end-effectors. Manipulators are rail-guided; rails are mounted to the SF's roof structure.
5. **V/HDS (jib cranes):** Two jib cranes are operated lengthwise along rails on top of the SF. The jib cranes can be operated via remote control or automatically.
6. **Welding Robot System for Columns:** The welding robot system for columns is a mobile STCR which has been integrated into the (integrated) site operation. The mobile system is moved over the pre-completed floors to the column to be welded, where it is positioned by and aligned with the column by the manipulator. The robot embraces the column and welds it simultaneously from two sides at once, so that any distortion of the steel column by the welding process is avoided. Several welding robot systems can be used to weld columns in parallel.
7. **Welding Robot System for Beams:** The welding robot system for beams is positioned by the manipulator on top of the preliminary fixed beams to weld/attach the beam components to the column components. The welding system consists of two frames used for the attachment to the beams and four welding robots with one welding head each mounted on top of these frames.
8. **Mobile (horizontally/floor wise operating) Logistics Robots:** On the floors within the SF already covered with ceiling elements, and which are thus no longer accessible to the OMs, mobile logistics robots are used for horizontal material delivery (mainly for the delivery of material for interior finishing). The logistics robots are integrated with the RTMMS and can communicate with the automatic vertical lifts in order to achieve JIT and JIS material delivery.
9. **AAMS:** Sets of optical sensor systems (stereo vision systems, 1-D and 2-D laser scanning systems) are used to support the alignment and accuracy measurement process.
10. **RTMMS:** Data from the sensor systems, as well as from the servomotors/encoders of the vertical HDS, along with information obtained from cameras monitoring all activities (including human activities) in the factory, are used to create a real-time representation of equipment activity and of the construction progress. A barcode system allows representation and optimization of the material flow and allows equipment (e.g. the automatic lift) to identify the component being or to be processed. Real-time monitoring and management is done in a fully computerized on-site control center (**see also 5.4, efficiency analysis**).

End-effectors: The manipulators (HDS) can be equipped with various end-effectors to suit the pickup, positioning and adjusting of various types of component:

1. End-effector for picking up, positioning and adjusting columns
2. End-effector for the horizontal delivery of multiple beams or steel profiles

3. End-effector for the positioning of beam/column components
4. End-effector for picking up and positioning concrete floor slabs
5. End-effector for delivery and positioning of the welding robot system for beams.

System Variations: The strategically important area of the building can be varied in location as well as in size. The SF is modular in itself and is a physical and informational platform for the installation of subsystems in various configurations.

ROD: On a component level, the size, dimension and weight of components is designed so that they can be manoeuvred by the OM system. On a building level, the allocation of the SF in a dedicated and strategically important area is taken into consideration during planning. On an urban level, the location of the automatic lift, its accessibility to delivery systems such as trucks etc. on the ground level, and its relation to the SF can all be taken into account when deciding the orientation of the building in the environment.

Hybrid Shimizu Manufacturing System by Advanced Robot Technology (Hybrid-SMART)

Company: Shimizu Corporation, Japan

Category: Centralized SF (moving upwards) in combination with conventional construction



SF

Evolution Scheme: The Hybrid-SMART is applied to buildings with a large floor area. In order to optimally use the capacity of the automated OMs, the SF is erected only over a strategically important area of the building (e.g. the core area of a building containing staircases, elevators and major parts of the building technology). The floor area surrounding this strategically important area is erected in parallel, not by use of the OMs but by the use of rail-guided (optionally robotic) jib cranes, human labor and logistics support from the SF.

Elevation: As in the SMART, the steel stilts that support the SF do not rest on top of the columns but between them – thus the climbing process interferes less with component assembly process. Within the Hybrid-SMART work is done on three to four levels in parallel. Components are positioned and aligned on the uppermost floor (the n th floor). Activities such as component fixation, interior finishing and facade work (over platforms provided by the SF) are done on the floors below.

Ground Plan: The ground plan shows that the SF spans the core area of the building, as well as a side part. The allocation of the factory thus allows for the more complex core assembly part to be done or supported by the OMs, for an automatic lift to be installed and connected to the SF, and for the not so complex office areas surrounding the core to be erected in parallel by the more human based methods.

Subsystems: The SMART system manufacturing the building on-site by way of an SF consists of a multitude of integrated subsystems. The trolley hoist manipulators freely travel throughout the system by automatic vertical lifts and automatic overhead cranes. They thus integrate vertical and HDSs and take away the necessity of handing over components between them, thus eliminating waste processes (consider the waste which occurs in other systems due to the handover between vertical and HDSs, e.g. the resulting idle time of the component and the time necessary to accomplish handover; additionally, consider the possibility of damage to components during handover).

1. **SF Structure:** In order to optimally use the capacity of the automated OMs, the SF is erected only over a strategically important area of the building. The SF completely covers the automated construction area. The SF provides a platform for the attachment of the OMs, the rail-guided jib cranes (that serve the not-automated construction area) and the CS.
2. **CS:** Four lifting stilts are positioned inside the factory to lift the whole factory. In contrast to many other systems which use SFs, the hydraulic lifting mechanism is not located in the roof structure itself but on the bottom of the stilts. Inchworm-like, the mechanism moves from floor to floor, pushing up the stilts and thus the factory.
3. **Trolley Hoist OM System (optional):** In the Hybrid-SMART, multiple trolley hoist OMs are operated in parallel. Each trolley manipulator can travel between material handling systems on the ground and the SF's automatic overhead gantry crane system, thus integrating pick-up, vertical delivery and positioning processes.

4. **SF HDS (optional):** Multiple mobile overhead cranes travel the building in a fixed lengthwise direction. However, the trolley hoist manipulators can travel between the cranes. Thus, the trolley hoist manipulators can travel to any point on the XY-axis. Multiple overhead cranes can build a line (transport channel) along which the trolleys can travel.
5. **Gantry-type OMs (optional):** Instead of the SF HDS simpler gantry-type OMs can be installed within the factory to perform component positioning operations.
6. **VDS (lift of trolleys/manipulators):** The trolley hoists pick up components from the ground floor and travel with the component via the automatic vertical lift into the factory. In case the SF is equipped with the simplified gantry-type OMs the automatic vertical lift only delivers components.
7. **V/HDS (jib cranes):** Two jib cranes are operated lengthwise along rails on top of the SF. The jib cranes can be operated via remote control or automatically.
8. **Welding Robot System:** Compared to other welding robot systems, the Shimzu welding robot system used within the SMART as well as the Hybrid-SMART is compact and lightweight. It consists of a ring which encircles the column and a single welding robot guided by this ring. Many of these systems can be used in parallel. Each welding robot system determines its welding path by a laser sensor and automatically welds the steel columns together.
9. **RTMMS:** Each construction element is tagged with a barcode. This code is scanned and the individual element is processed by the distribution system according to its position in the building. A control room is located in the roof structure of the SF.

End-effectors: As in the SMART all trolley hoist manipulators in the Hybrid-SMART are equipped with multipurpose hooks, which are lowered/lifted by two ropes from the trolley manipulator's main mechanical part'. The simplicity of the end-effectors is accomplished by ROD.

System Variations: The SMART-Hybrid is composed of elements of the SMART stating a fully modular kit. The automated part of the Hybrid-SMART (covered by the SF) can be used to construct rectangular building core areas with an orthogonal alignment of components. The sections of the building arranged around the core area are built by the not automated part of the Hybrid-ABCS and can be of any shape; orthogonal alignment of components would be advantageous but is not a prerequisite for the use of the system. The SF can be equipped either with the Trolley Hoist OMs of the SMART or with with simplified gantry-type OMs.

ROD: On a component level, the use and operation of the OMs is simplified by compliant and self-adjusting column joints (rack and pinion system). On a building level, the structure of the overhead crane system has to be synchronized with the shape and dimensions of the building's core area. The core are which is covered by the automated part (SF) of the

Hybrid-SMART has to cover on the one hand a in terms of logistics and component supply through the automated part manufacturing strategically advantageous area of the building and on the other hand a rather complex section of the building which justifies the use of the OMs.

5.2.10 Decentralized Sky Factory (moving upwards) in Combination with Conventional Construction

Systems in this category are characterized by the application of decentralized and loosely coupled subsystems of SFs. So far all systems within this category have been the result of the phenomenon of technology diffusion, meaning that highly automated SFs were split into their subsystems and that the subsystems were used independently from each other and not combined in order to fully integrate automated supply chains such as in the original versions. Both Obayashi and Shimizu use those subsystems (e.g. automated component lift, automated welding systems, etc.) in conventional construction sites along with conventional work processes. The decentralised and loosely coupled use of the automated subsystems accounts for flexibility and low machine costs on the one hand, but on the other hand this strategy is unable to achieve high productivity in terms of time reduction or a reduction in human labor.

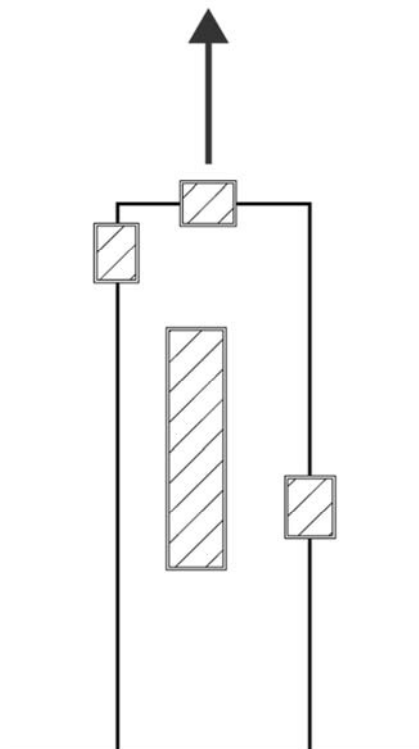

	System Name	Company
23	Loose Deployment of ABCS-Subsystems (e.g. Tokyo Sky Tree)	Obayashi
24	Loose Deployment of SMART-Subsystems (e.g. Gakuen Cocoon Tower)	Shimizu

Two recent and well known examples of the application of SF subsystems in a decentralized manner are the erection of the Tokyo Sky Tree (here Obayashi applied ABCS and Big-Canopy Subsystems) and the erection of the Gakuen Cocoon Tower in Tokyo (here Shimizu applied Subsystems of the SMART). Apart from these two projects, both companies apply subsystems of their automated site systems frequently in conventional construction projects. The application of subsystems relates the technological development in the field back to the idea of single-task robots (described in **4.1**). Individual automated technologies are coupled to cooperating systems that are compatible with conventional construction processes, but which are not as rigidly interconnected and automated as full versions of automated sites. As the application of subsystems provides advantages in terms of flexibility and cost it is highly likely that in the future individual subsystems or sets of subsystems will be developed for loosely coupled and decentralized use.

An Example of a Decentralized Subsystem Application of Automated Building Construction System (ABCS subsystems)

Company: Obayashi Corporation, Japan

Category: Decentralized SF (moving upwards) in combination with conventional construction



Tokyo's Sky Tree was constructed using ABCS subsystems

Evolution Scheme: Today, Obayashi uses sub-systems developed for the use in ABCS more frequently as loosely coupled elements and not as centrally integrated elements within on-site construction. The use of subsystems of ABCS was not foreseen when ABCS was developed in the 1990s. The use in, and fusion of, highly complex ABCS technology with conventional construction methods and technologies can be seen as a form of technology diffusion. Obayashi recently applied ABCS subsystems in a loose combination to support the construction of the Tokyo Sky Tree.

Elevation: Using and adjusting ABCS Subsystems was, in the case of the Tokyo Sky Tree, highly efficient, as the 634 meter tall structure is an extreme project requiring high precision and technical support. Obayashi used prefabricated, large scale steel elements to construct the Tokyo Sky tree. As the Tokyo sky tree is extremely high, it has to behave exactly as predicted in the event of an earthquake, and a high-level of precision is necessary in component alignment. At extreme heights, welding support is also necessary, as well as an efficient parts and components delivery system. Obayashi therefore decided to use adjusted versions of various ABCS subsystems (subsystem for alignment and accuracy management, subsystem for vertical logistics automation, subsystem for welding automation).

Ground Plan: In the event of the loose combination of ABCS subsystems, the idea of a factory which covers the building completely (ABCS) or partly (Hybrid ABCS) is abandoned and subsystems are applied in a more loose combination. With the abandoning of the factory structure, OMs and CSs are also abandoned. All other subsystems become optional elements that can be used individually or in a combination, and are integrated by the management of a RTMMS. However, in many cases the vertical logistics subsystem (automatic lift) plays a central role.

Subsystems: The optional subsystems that can be used in a loose combination in a decentralized factory are listed below. As the combination is loose, other machines and systems with network capability can simply be added. The list thus only shows the basic subsystems but not the complete possibility of the system.

1. **VDS (optional, but basic):** Being challenged by the highly compact and crowded central areas of Tokyo, which do not allow major disturbances by construction, Obayashi, like other major Japanese contractors, has developed JIT, JIS type supply and construction methods. A set of such methods was also applied in the construction of the Tokyo Sky Tree. Inside the steel frame core, an ABCS subsystem for automated logistics was installed to make the site logistics more efficient. This installation pays off especially in the building of a 634 meter high tower.
2. **Facade Element Delivery and Installation System (optional):** Under the factory roof, along the facade (outside of the floor area but along the building facade/edges), a rail-guided crane manipulator system can be installed for lifting and positioning of facade elements.

3. **Welding Robot System: Welding:** At a height of 634 meters (such as with the Tokyo Sky Tree), even the smallest aberration in the structure can weaken it and hinder the alignment of another large scale prefabricated segment in subsequent construction phases. When the high precision alignment and joining of steel segments has to be guaranteed, Obayashi's automated welding systems are a major advantage. The welding system precisely and simultaneously welds elements around the joint from opposite sides. Welding from opposite sides, or in a specially assigned sequence, can guarantee that the joints and thus the segments do not distort during the welding process. The ABCS welding subsystem is controlled by welding software and allows the simultaneous welding by multiple robots on one joint.
4. **Mobile (horizontally/floor wise operating) Logistics Robots:** On floors within the SF that are already covered with ceiling elements
5. **AAMS:** The construction of the 634 meter high Tokyo Sky Tree structure required a high degree of precision to achieve the desired performance. To achieve this, the ABCS subsystem for automated and high precision column alignment of steel structures was used. This system had been improved for the construction of the Sky Tree.
6. **RTMMS:** Data from sensor systems, as well as from the servomotors/encoders of the V/HDS used for management and real-time control of the construction process.
7. **Further Subsystems:** As the combination is loose, other machines and systems with network capability can simply be added. In case of the Tokyo Sky Tree an automatically rinsing/climbing and adjustable concrete slip form was added as sub-system in order to be able to automate the construction of the inner concrete core of the Sky Tree.

End-effectors: As the OM system is not applied, the system of dedicated, component adjusted end-effectors that is closely related to these systems is also not applied. However, in the case of the Tokyo Sky Tree, for example, Obayashi developed a specialized (non-robotic) end-effector system that was attached to the conventional tower cranes which rose with the Sky Tree on two sides. The end-effector system allowed the efficient picking up and positioning of the prefabricated, large-scale steel elements.

System Variations: The loose and decentralized combination of subsystems allows the ABCS application to be almost independent from column grid structures, and also from vertical or horizontal orthogonality. In the case of the Tokyo Sky Tree, this flexibility was necessary, as the building's form and composition frequently changes from bottom to top.

ROD: On a component level, the size, dimension and weight of components has to be designed to fit the requirements for use by the subsystems (e.g. automatic lift). Additionally, on a building level, the allocation of the vertical logistics subsystem needs to be decided. In the case of the Tokyo Sky Tree, the inner, concrete based round core, determined the position of the automatic lift.

An Example of a Decentralized Subsystem Application of Shimizu Manufacturing System by Advanced Robot Technology (SMART subsystems)

Company: Shimizu Corporation, Japan

Category: Decentralized SF (moving upwards) in combination with conventional construction



Self-climbing cover and scaffolding structure partly structuring the assembly environment on-site

Evolution Scheme: Shimizu used concepts, techniques and subsystems that were initially developed for the concentrated application within SMART in a loosely coupled and only partly automated form to construct the Gakuen Cocoon Tower in Tokyo. In a temporary GF, parts and components were transformed into higher level components (steel structure components, facade components) in order to minimize assembly work for the complex structure on top. The high-level steel structure components were assembled in the SF, while on the lower levels the facade components were attached by tower cranes equipped with component adapted, specialized balancing end-effectors.

Elevation: The steel main structure was assembled on the uppermost floors. A factory structure providing side cover and working platforms to support fixation and welding operations climbed up the assembled structure. A vertical lift was installed within one of the three main shafts, which delivered the structure and facade components to the top to be picked up by the tower crane manipulators. The vertical lift picked the components up from a temporary GF installed on the ground level cafeteria part of the building. A chain-like manufacturing sequence was established on-site for the on-site transformation of facade parts into high-level facade components.

Ground Plan: Around the building's central core, the steel structure of the building created three vertical shafts. Extendable tower crane manipulators were positioned in two of the shafts; in the third shaft, a vertical lift was installed which delivered components from the GF to the operational floors at the top of the building.

Subsystems: The decentralized site-manufacturing setting (system) consists of many (integrated) subsystems:

1. **Climbing Cover and Scaffolding:** A climbing cover and scaffolding structure spanning two floors climbed along the structural components located on the top floor. It provided a weatherproof and safe environment, as well as outside working platforms for final fixation and welding.
2. **VDS:** In the third shaft, a vertical lift was installed, delivering components from the GF to the operational floors on top of the building. Multiple components (e.g. up to six facade components) could be delivered at once.
3. **Vertical/Horizontal Installation System:** In two of the shafts, extendable tower crane manipulators were positioned, which were capable of being equipped with different end-effectors.
4. **Welding Robot System (optional):** Shimizu also had the option of using its column attachable welding robots within the weatherproof climbing cover and scaffolding.
5. **GF:** For the on-site transformation of facade parts into high-level facade components, a chain-like manufacturing sequence was established on-site (delivery of parts, joining of delivered frames to larger elements, installation of glass and random strips, sealing). Components in the temporary GF were assembled JIT and JIS, according to the

installation sequence in an SF. Software was used to simulate and optimize the assembly sequence.

6. **RTMMS:** Software was used to simulate the construction process, and to optimize the assembly sequence of the elements of the complex not-rectangular facade in particular.

End-effectors: As was demonstrated with the the Gakuen Cocoon Tower in Tokyo , the vertical/horizontal installation system can be equipped with various end-effectors suiting the pickup, positioning and adjusting of various component types:

1. End-effector for pickup, positioning and adjusting of structural steel components
2. End-effector with a balancing device for orientating and positioning facade components.

System Variations: The Gakuen Cocoon Tower in Tokyo has shown how the loose coupling of subsystems initially developed for the SMART can allow a complex shaped building, in which nearly every floor, structural element and facade element is different, to be erected in a structured and systemized on-site environment.

ROD: The structural steel structure surrounding the inner core and shafts of the Gakuen Cocoon Tower was modularized into a kit of columns, beams and corner components with joints that simplified temporary fixing after the positioning. Even though the facade seems to have an irregular structure, the facade was modularized into rectangular elements that could be assembled in the GF, and that simplified the installation process.

5.3 Technical Analysis & Categorization: Deconstruction

Since 2008, when Kajima started the deconstruction era, the six major Japanese contractors had developed mechanized and partly automated deconstruction systems. Deconstruction systems follow the same approach as automated construction sites and install an on-site factory (fixed type or moving type), which then provides the basis for controlled, structured and systemized on-site work processes. The cover of the on-site working area provides - apart from the advantage of creating a weatherproof and disassembly supportive environment (with the possibility of installing overhead cranes, cameras and other measuring technology) - especially in building deconstruction, the advantage of being able to reduce the noise and dust disturbance to the surrounding environment (e.g. in the case of the TECOREP system, noise disturbance for the surrounding environment was reduced to less than 20 decibels). Deconstruction sites are work environments where processes are, in a factory like manner, phased to a strict time schedule, and the flow of material is highly organized. Deconstruction sites thus follow the general idea of an SE.

Deconstruction in Japan is a thriving market. Due to the growing population density, a huge number of high-rise buildings have been constructed since the early 1990s. Many of those high-rise buildings are no longer considered to be 100% fail-safe, due to advanced knowledge of structural design and due to a change in thinking and requirements after the March 2011 earthquake (magnitude: 9,0) and the predicted increase of earth-quakes in the future. Developers and owners of those high-rise buildings thus have to consider either the (costly) integration of damping systems or complete deconstruction and rebuild. The second method also has the potential benefit that during a rebuild, buildings can also be adapted to new functional, technological and ecological requirements. This requires, however, that the deconstruction and rebuild can be done faster than with conventional methods. As the deconstruction and rebuild of high-rise buildings is a highly profitable business in Japan, and a huge amount of combined deconstruction/rebuild orders are expected over the next decade, major Japanese contractors are competing over deconstruction ability and speed.

A further advantage of systemic or automated deconstruction – especially in the Japanese economic environment – is, that apart from the high speed of deconstruction, the achievement of (compared to conventional demolishing) an extremely high rate of recyclability or reusability of the deconstructed materials, parts and components (in case of a DARUMA application in Tokyo, the recycling rate exceeded 90%). The deposit of construction material in Japan is highly expensive, as due the country's geographical features (limited island area, many hills and mountains, large wooded areas, limited possibility of creating habitable space), the population density is high and construction waste represents a threat to the possibility of using this space efficiently. Additionally, since about 2005, the Japanese government has been promoting making the construction sector more sustainable (houses ought to be able to last 250 years, reduction of resource and energy consumption). Since the 2011 Tohoku earthquake, and related Fukushima nuclear

power plant incident - which led to a permanent shutdown of nearly all 50 nuclear reactors in Japan, the saving of resources, as well as the change towards ecological thinking has become a key issue in Japanese society, industry and science.

Most deconstruction sites firstly disassemble the larger (high or low-level) components, then disassemble those components (e.g. in a GF like setting) on-site into lower level components, mono-material parts or raw materials which can then be delivered directly from the site to the recycling plant or enterprise. Furthermore, the research departments of some companies (e.g. Kajima) are currently seeking ways to convert deconstructed material directly back into usable building material on-site. Similar to automated construction, central to the on-site demanufacturing process are, apart from the implementation of a controlled environment and controlled material flow, the use of overhead crane systems, vertical logistics lifts and of sensor and measurement technology for computer supported monitoring of the construction process (progress monitoring, decibel monitoring, dust and CO-2 ratio monitoring).

Deconstruction sites are operated – just like automated construction sites - on a 4-7 day cycle (time planned for deconstruction of a single floor). The automation ratio of deconstruction sites is (to date) lower compared to automated construction sites, and many subsystems are remote-controlled and human supervised. This is, on the one hand, due to the higher flexibility required in deconstruction and, on the other hand, due to the lower implementation costs necessary. However, as more and more companies start using deconstruction systems, the pressure to improve the existing systems increases, and companies are likely to improve the methods and technology through repeated use. When contractors are asked in the future to deconstruct buildings which were actually constructed using automated technology, the possibility of using previously generated systems and data sets for fully automated deconstruction could be explored.

Most companies are also aiming at, apart from the above mentioned advantages, higher productivity and the reduction of human labor. Systems in the following section that are categorized under category one or three can potentially reduce the amount of human labor required. Systems in category 2, on the other hand, aim less at significant cost and time savings, but rather focus on addressing the advantages of increased safety, a higher recycling rate and less disturbance to the environment. Taisei, which has so far deconstructed buildings of up to 105 meter high, has stated that highly time and cost efficient deconstruction could be accomplished by TECOREP when the building to be deconstructed is higher than 150 meters. Basically, for deconstruction, the same analysis framework as for automated construction sites could be applied. Deconstruction sites also use climbing subsystems, factory subsystems, logistics/crane subsystems and subsystems to control the deconstruction in real-time. New or different to automated construction are the deconstruction subsystems for the real-time supervision of noise and dust/dirt levels. Furthermore, deconstruction required some new types of end-effectors (e.g. material sorting for recycling, water-cutting, laser-cutting).

5.3.1 Closed Sky Factory Supported by Building (moving downwards)

To date, two deconstruction systems have been developed in this category. Systems in this category are characterized by the installation of a CSF on top of the building. Within the CSF, the building is deconstructed from top to bottom. Similar to automated construction, the lifting mechanism (in the case of deconstruction this is better referred to as a lowering mechanism) that allows the lowering of the factory after each floor cycle is key. Two variations of lowering mechanisms in this category can be identified so far:

- The Hat Down factory is lowered by a mechanism which encompasses the building from outside and penetrates the facade at certain clearly defined points, in order to get a grip on structural elements.
- The TECOREP factory is lowered by a mechanism which vertically penetrates the inner floors at certain clearly defined points, and which also uses the floor structure to get a grip

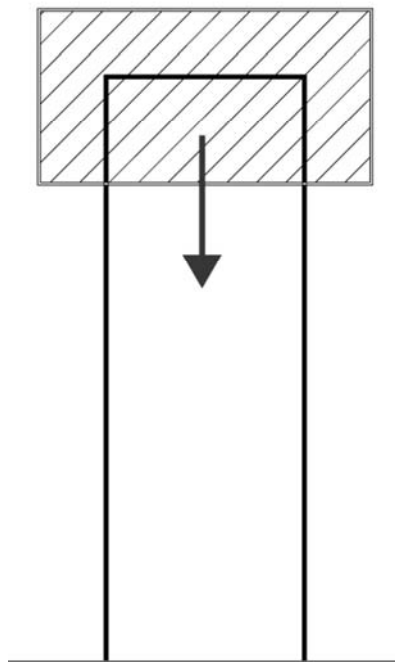

	System Name	Company
25	Hat Down	Takenaka
26	Taisei Ecological Reproduction System (TECOREP)	Taisei

The Hat down factory is a completely new structure assembled on-site. The TECOREP factory utilizes parts of the building that are to be deconstructed and uses one of the top floors as the basic structure and roof of the factory, to which it assembles the overhead cranes and the side covers. All systems in this category disassemble larger elements in the SF, with additional disassembly on the ground floor.

HAT Down

Company: Takenaka Corporation, Japan

Category: Deconstruction - closed sky factory supported by building (moving downwards)



Deconstruction by SF

Evolution Scheme: Takenaka Corporation developed the Hat Down method, which allows the demolition of high-rise buildings in the centers of cities and other complex locations by installing a movable demolition work space (the Hat) so that the top of the building is enclosed. It then climbs down as the building is demolished from top to bottom. The Hat, in which demolition equipment is integrated, including ceiling cranes and other subsystems, gaplessly encloses the demolished building's body during lowering. All the demolished materials are lowered inside the building, permitting a demolition process that is safer and kinder to the environment than conventional methods. The method debuted at the demolition of the old Hotel Plaza in Osaka, in February 2008.

Elevation: The major specifications of the Hat used for this work were:

- Height: 19 meters,
- Width: 19.6 meters,
- Length: 92.3 meters, and
- Weight: 412 tons.

The outside was completely covered with soundproof panels and its ceiling was constructed so that it could be opened and closed, depending on the conditions. Twenty-two jacks were installed to raise and lower the Hat, and after the interior of the floor where the Hat had been installed was demolished, the entire Hat was lowered down to the next floor (2.95 meters) in about one hour to prepare it to demolish the next interior. Meanwhile, at the bottom of the building, all the lowered elements were processed in order to separate the different materials and recycle them or use them on another construction site.

Ground Plan: In the case of Hotel Plaza in Osaka, the floor to be demolished was divided into three sections, each with a ceiling crane and a lowering opening. Workers worked simultaneously in all three sections, breaking the columns, walls, floors, etc. into about 180 pieces per floor, and then lowering these to the ground floor through the lowering openings. The work was scheduled to be executed from the 23rd floor, to the 5th floor between February and July, while lowering the hat 14 times. The bottom four floors were crushed with heavy machinery. As can be inferred by analyzing the ground plan, this system works better when applied to buildings with a big difference between their length and width as this allows for an optimal utilization of the OMs and the parallel processing in various factory parts. To apply the method to a building with a more complex geometry, additional arrangements would have to be made in order to make it functional. Additionally, it is useful to find existing openings that connect different levels of the building to use as lowering openings for the system, such as elevator shafts.

Subsystems: The Takenaka HAT Down system consists of many integrated subsystems:

1. **SF Roof Structure:** A lightweight steel frame structure spans the building and provides a platform the installation of the gantry type OMs. All the cover of the SF is made by sound proof panels in order to balance the loud and dusty conditions of the inside, with

the peaceful surroundings. This allows the performance of complex assignments with a low impact on the environment and neighboring community.

2. **CS:** The system is supported by two grippers that hold themselves to each column of the building using compression and friction. The structure slides down via the installation of a third gripper one level below. The gripper on top is then removed and a new level is ready for demolition.
3. **HDS:** Each of the three zones has a gantry type OM to transport the demolished components down to the ground level. They can move in the 3 directions X-Y-Z along the main beams of the system, allowing them to have the whole of the building inside their workspace.
4. **Lowering Openings:** They allow the trolley cranes to move all the materials down to the ground level. They are a continuous interruption in the floor structure, running through every level supporting the logistic organization of the system. They are projected through the smart utilization of already existing elevator shafts and similar.
5. **Adaptable Ceiling:** It is constructed with a flexible light material so that it can be opened and closed at will. So, depending on specific conditions like the weather, temperature and humidity, a better work environment can be provided for all those involved on the demolition project.
6. **MHSPY:** An MHSPY is installed in the ground floor of the building for disassembling of components and sorting of materials. Furthermore, materials are prepared in the MHSPY in order to be picked up by FEL. The pickup of components by FEL can thus be organized JIT and JIS.
7. **RTMMS:** A series of sensors are deployed all over the site to allow a strict internal control. Variables like electric current and voltage are controlled to raise performance, quality and safety. Aspects like temperature, humidity, noise levels and CO₂ emissions are also controlled to maintain the best working conditions.
8. **Solar Panels:** Solar panels located on the exterior walls of the system's enclosure absorb photovoltaic energy from the sun's radiation and transform it into electricity to provide for some of the power requirements in the interior.
9. **Template for Cutting:** When demolishing the columns of the building, the gripper of the climbing mechanism is used as an outline for making a clean cut at the base of the columns. In this way a standardized size of column elements is assured and no additional procedures are required (schedule and budget).

End-effectors:

1. **Climbing Gripper:** They transmit all the weight of the demolition plant to the columns of the building. They are assembled using two identical elements placed on

opposite sides of a column. Using bolts, the two elements are pulled towards each other with enough force to hold them in place on the column of the building.

2. **Crane Hook:** The cranes are equipped with a standard lockable hook, whose position is determined by the crane mechanisms. The demolished elements are attached to the hooks by the workers using ropes and steel cables.

System Variations:

- **Longitudinal Expansion:** The system is mainly applied to buildings with one considerably longer dimension. This is because the cranes need rail beams that cannot usually be separated more than 25-30 meters. While this parameter must remain at this interval, the system can be easily expanded in the other direction (lengthwise).
- **Multidirectional Expansion:** Also easily implemented if the internal columns of the building are inside the 25-30 meter interval and supported by the cranes workspace. The system can easily support innumerable shapes of buildings without big adaptations, so long as this requirement is fulfilled.
- **Transversal Expansion:** If the 30 meter limit is not complied with, the system needs to be expanded transversally. This would generate the need for intermediate supports for the cranes, and this may include the integration of new subsystems or components. It increases the complexity considerably.
- **Internal Supports:** The need for internal supports creates a big problem for the CS, since it is only designed to work from exterior columns. A good solution would be to use the same basic mechanism, but to handle the internal supports with a one story offset. This way, the internal grippers are one level above ($n+1$) the external ones (n). After the demolition has been completed in level n , the internal columns in $n+1$ became external, and the climbing down can be performed as planned.

ROD: On a parts or low-level components level, the number of different types of materials ought to be minimized - this would simplify the process of sorting materials on-site and reduce transport to separate reprocessing plants. Hazardous or toxic materials should also be avoided - this will reduce the potential of contaminating materials that are being sorted for recycling and will also reduce the potential for health risks during disassembly. Secondary finishes and coatings should be avoided where possible - such coatings may contaminate the base material and make recycling less practical. Permanent identification of material types should also be provided - many materials such as plastics are not easily identified and should have some form of non-removable and non-contaminating identification mark to allow the future sorting of materials. With higher-level components, the number of different types of components ought to be minimized, to simplify the sorting process. Additionally, mechanical connections ought to be used rather than chemical ones - this will allow the easy separation of components and materials without force, and reduce contaminating materials and damage to components. Chemical bonds should also be made weaker than the parts being connected - this way the bonds will break during disassembly rather than the components. The structure should be separated from the cladding, the internal walls, and the services - this allows parallel disassembly where some parts of the building may be removed without affecting others. A minimum number of different types of

connectors should also be used - standardization of connectors will make disassembly quicker and require fewer types of tools. On a building level, parts ought to be standardized while allowing for an infinite variety of the whole - this will allow minor alterations to the building without major building works. A standard structural grid should also be used - grid sizes should be related to the materials used such that structural spans are designed to make most efficient use of the material type. Additionally, the points of disassembly should be permanently identifiable and not be capable of being confused with other design features. All information on the building's manufacture and assembly process needs to be maintained: measures should be taken to ensure the preservation of information such as "as built drawings", information about disassembly processed, material and component life expectancy, and maintenance requirements.

Taisei Ecological Reproduction System (TECOREP)

Company: Taisei Corporation, Japan

Category: Deconstruction - CSF supported by building (moving downwards)



SF used for systemic deconstruction (picture taken from Deconstruction Report)

Evolution Scheme: The TECOREP uses the roof of the building as the roof of the SF. The lifting/lowering mechanism is installed and the columns of the uppermost floor are cut. The roof of the building is connected via the lifting/lowering mechanism and side shelters covering the workspace and providing working platforms for facade work, and a rail-guided OM system is attached to it. Further vertical shafts are created, through which disassembled parts and components can be lowered to the ground floor, where material is handled and sorted.

Elevation: The climbing mechanism “breaks” through the floor slabs floor by floor, lowering the SF after the uppermost floor has been disassembled. Work is done on several floors in parallel. On the floors under the uppermost operational floor, the breakthrough of the climbing mechanism is prepared, and the interior finishing is disassembled. On the uppermost operational floor, the main structural components of the building are cut off and then picked up and lowered by the OMs.

Ground Plan: Compared to OSFs, TECOREP provides not only provides the advantage of creating a relatively independent environment to reduce the disturbance to the surrounding environment, but also the possibility of installing overhead cranes, cameras and other measuring technologies. The CSF method is the best solution for the outside environment; noise disturbance is reduced to lower than 20 decibels.

Subsystems: The TECOREP system, which systemically disassembles buildings on-site, consists of many integrated subsystems:

1. **SF Roof Structure:** The basic element of the SF is the roof of the building to be deconstructed, which covers working platforms, the climbing mechanism, and is the element to which OMs are connected. The SF completely covers the building and provides a weather immune SE, while lowering the sound and dust disturbance to the environment.
2. **CS:** The CS equals that of Takenaka’s Hat Down in its composition. The CS consists of two main parts: core and frame. On the core there are three column grippers. The grippers grasp the column over three different storeys. The frame also has three grippers, which are placed on the floor slab to secure the system’s position. However, in contrast to Takenaka’s Hat Down, the climbing mechanism does not operate along the facade, but from within the floor area itself, therefore having to break through floor by floor. The advantage is that the facade does not need to be prepared for the attachment of the climbing mechanism.
3. **V/HDS:** automatic rail-guided overhead gantry type manipulators are installed to the SF’s roof. The manipulators are used to hold components during disassembly (such as cutting them off), to pick them up and transport them horizontally over a vertical delivery shaft, and to lower them through the shaft down to the ground.

4. **MHSPY (part of GF):** In a MHSPY, the disassembled components lifted down from the SF are disassembled further; material is sorted and prepared for transportation. Through preparation and sorting, the amount of material to be disposed of is reduced to a minimum.

End-effectors: The manipulators are equipped with multipurpose conventional crane end-effectors. However, in order to guarantee a precise disassembly, new methods for on-site water and laser cutting are applied and tested.

System Variations: The installation of the SF and the CS do not require synchronization with the building's grid of columns. The subsystems can be installed to almost any building that allows that the roof structure to be used as a platform for mounting the described subsystems.

ROD: To date, no building code or guideline exists which, upon being applied, would simplify the use of TECOREP.

5.3.2 Open Sky Factory Supported by Building (moving downwards)

To date, three deconstruction systems have been developed in this category. Systems in this category are characterized by the fact that the building is deconstructed from top to bottom and that the roof of the SF is not completely closed and thus it is called an OSF. The factory only has side walls and encompasses the building like a closed band, moving downwards along the facade. The factory's main purpose is thus to limit the disturbance to the surroundings (aesthetically, and from noise and dust), and to provide assistance and platforms for dangerous disassembly work on the facade.

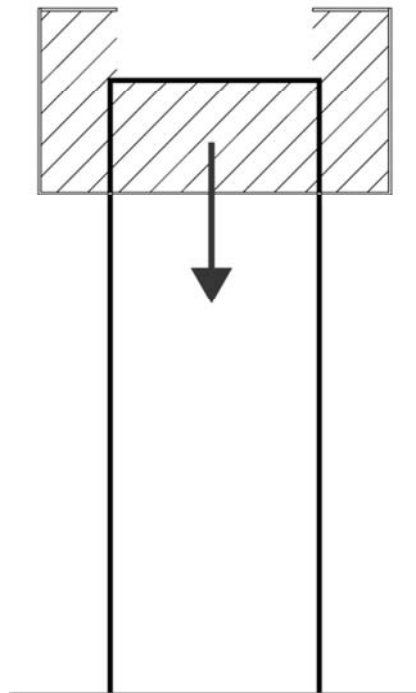

System Name	Company
27 Move Hat	Nishimatsu
28 Reverse Construction Method (RCM)	Shimizu
29 Quakeproof, Quiet, Quick and Block-by-Block (QB Cut-off)	Obayashi

The pick-up and lowering of components is done using standard cranes. On the one hand, the control and structuring effect of the work environment and logistics processes can be considered as being lower compared to the former category of systems with closed roofs. On the other hand, these systems are less capital intensive than the systems of the former category, and can thus be developed and implemented faster and at a lower cost. Systems

in this category require almost the same time and cost as for conventional demolishing, but have the advantage of more safety, a higher recycling rate and less disturbance to the environment.

Move Hat

Company: Nishimatsu Corporation, Japan

Category: Deconstruction - OSF supported by building (moving downwards)



Move Hat SF begins operation (RIBC, 2012)

Evolution Scheme: The OSF is set-up on the ground floor and then lifted via the climbing mechanism to the top of the building, where it partly covers the workspace and provides space for the operation of OMs, as well as safe working platforms and protection of the environment from noise and dust. The final disassembly and the break-down of components into individual parts and materials are conducted by a GF.

Elevation: The elevation shows the open roof structure of the SF and the working space of the OMs used to efficiently disassemble facade elements and outer structural elements. The SF encloses the workspace and provides the basis for structuring the working environment. It gives protection against the wind, sun, and rain.

Ground Plan: Depending on the size of the building, a variable number of inchworm climbing mechanisms and VDSs can be installed. The open roof structure is modularized so that it can be adapted to huge variety of orthogonally organized steel and concrete based buildings.

Subsystems: The Move Hat system, which systemically disassembles buildings on-site, consists of many integrated subsystems:

1. **OSF Structure:** The SF of the Move Hat does not enclose the workspace completely but builds a covering ring around the top floors where the disassembly of structural elements is done. The SF does not span the whole building, but only the operational floors' external walls. The structure provides working platforms for efficient and safe disassembly work on the outside of the facade.
2. **CS:** The CS is attached to the outside of the building and, via hydraulic actuation, climbs up/down the facade. As the system can climb up/down the facade, the set-up of the CS and the assembly of the factory side covers can be done conveniently on the ground.
3. **Partial HDS:** The SF only provides a roof for the installation of 3-DOF OMs along the operational floors' sides (translation lengthwise, translation sideways, Lower/lift). The overhead cranes can thus be used to support the disassembly of facade elements and of the outer structural beams and columns.
4. **VDS:** Winch-based cranes are installed which lower the disassembled material via shafts created within the building's floor area.
5. **Lightweight Equipment:** Lightweight, conventional construction machines can be used on the operational floor
6. **MHSPY (part of GF):** The ground floors are also covered by a factory-like structure from the outside in order to prevent the disturbance of the environment by noise and

dust. Components lowered from the SF are disassembled further on the ground; material is sorted and prepared for transport.

End-effectors: The manipulators are equipped with multipurpose conventional crane end-effectors. However, in order to guarantee precise disassembly, new methods for on-site water and laser cutting are applied and tested.

System Variations: The installation of the SF and the CS do not require synchronization with the building's grid of columns. The subsystems can be installed to almost any building that will allow the roof structure to be used as a platform for mounting the described subsystems. As the elements of the SF are orthogonal, the building should also be orthogonal in order to avoid major adjustments. The facade of the building to be deconstructed should be stable enough for the application of the CS.

ROD: To date, no building code or guideline exists, which, upon being applied, would simplify the use of Move Hat.

Reverse Construction Method (RCM)

Company: Shimizu Corporation, Japan

Category: Deconstruction - OSF supported by building (moving downwards)



Evolution Scheme: The RCM SF does not cover the workspace, providing only a movable protection ring around the top floors where disassembly is done. Firstly, the interior plumbing elements are removed from the building (and vertical shafts created) and a tower crane capable of being lowered in parallel to the SF is set up. Secondly, the scaffold unit (OSF) is assembled on the ground and lifted up along the facade. Thirdly, the building's shell is cut into blocks so that it is suitable for vertical logistics – deconstruction proceeds floor by floor. Finally, the OSF is disassembled on the ground.

Elevation: In contrast to other systems, the RCM does not work with overhead cranes or lifts lowering the material within the floor or via shafts, but uses a tower crane as a central element, which can be lowered floor by floor in parallel with the SF. The open roof structure allows the tower crane to access all locations to pick up building components and parts.

Ground Plan: A centrally positioned tower crane spans the work area and accomplishes the lifting up of equipment as well as the picking up of components to be disassembled.

Subsystems: The RCM system systemically disassembling the building on-site consists of many integrated subsystems:

1. **Open Factory Structure:** The SF only provides a side cover and working platforms for facade work. Due to the intended interplay with the tower crane, the final disassembly workspace on top of the building is not covered by a roof structure. The side cover provides the basis for the working environment (protects against the wind, and partially from the sun), as well as for reducing the impact on the wider environment (by preventing noise and dust).
2. **CS:** The CS is attached to the outer side of the building and, via hydraulic actuation, climbs the facade. As the system can climb up the facade, the set-up of the CS and the assembly of the factory side cover can be done conveniently on the ground, simplifying the set-up and disassembly of the SF.
3. **V/HDS:** A centrally positioned tower crane can be lowered floor by floor in parallel with the SF, following the operational sequence. The working space of the tower crane allows access to disassembled components and allows those to be lowered from the SF to ground.
4. **Vertical Delivery Shaft:** Deconstructed components can be lowered into the MHSPY through a vertical delivery shaft.
5. **MHSPY:** The disassembly of components, material sorting and preparation for transport are all done in a MHSPY, which is integrated into the ground floors of the building.

End-effectors: The V/HDS (tower crane) is equipped with multipurpose conventional crane end-effectors. However, in order to guarantee a precise disassembly, new methods for on-site water and laser cutting are being applied and tested.

System Variations: The installation of the SF and the CS do not require synchronization with the building's grid of columns. The subsystems can be installed to almost any building that enables the roof structure to be used as a platform for mounting the described subsystems. As the elements of the SF are orthogonal, the building should be orthogonal as well in order to avoid major adjustments. The facade of the building facing deconstruction should be stable enough for the application of the CS.

ROD: To date, no building code or guidelines exist, which, upon being applied, would simplify the use of RCM.

Quakeproof, Quiet, Quick and Block-by-Block Deconstruction (QB Cut-off)

Company: Obayashi Corporation, Japan

Category: Deconstruction - OSF supported by building (moving downwards)



Cutting off and picking up of component in OSF (RIBC, 2012)

Evolution Scheme: The QB Cut-off SF does not cover the workspace, providing only a movable and self-climbing protection and scaffolding ring around the top floors, where disassembly work is done. The SF can be erected on the ground and then lifted to the top by the climbing mechanism, where the disassembly operation starts. One or two tower cranes are erected besides the building and lift material/equipment in/out of the OSF.

Elevation: In contrast to other systems, the QB Cut-off does not work with overhead cranes attached to the SF, but integrates one or two tower cranes erected beside the building. The open roof structure allows the tower crane(s) to access all locations to pick up disassembled components. Disassembly work proceeds on several floors in parallel. On the uppermost floor, structural elements are cut off and delivered to the ground by the tower cranes. On the floors below this operational floor, interior finishing is disassembled and taken down by the automatic lifts.

Ground Plan: Strategically positioned tower cranes spans the work area and accomplish the lifting up of equipment, as well as the picking up of components to be disassembled. On the top floor, the building is cut into blocks suitable for vertical logistics (lifting). On the ground, those blocks are then further disassembled to smaller blocks or raw materials that can be recycled or reused.

Subsystems: The QB Cut-off system, which systemically disassembles the building on-site, consists of many integrated subsystems:

1. **Open Factory Structure:** The SF only provides a side cover and working platforms for facade work. Due to the intended interplay with the tower crane, no final disassembly workspace on top of the building is covered by a roof structure. The side cover provides the basis for the working environment (protects against the wind and partially from the sun), as well as for reducing the impact on the wider environment (prevents noise and dust).
2. **CS:** The CS is attached to the outside of the building and, via hydraulic actuation, climbs up the facade. As the system can climb up the facade, the set-up of the CS and the assembly of the factory side cover can be done conveniently on the ground, simplifying the set-up and disassembly of the SF.
3. **V/HDS (tower cranes):** Depending on the size of the building, one or two tower cranes are erected beside the building so that their workspace covers the whole floor area.
4. **VDS (automatic lift):** Obayashi uses adjusted versions of the automatic lifts used within ABCS, Hybrid ABCS, decentralized ABCS and Big Canopy for the lowering of disassembled parts and low-level components. Larger components are lifted down by the tower cranes.
5. **Lightweight Equipment:** Lightweight, conventional construction machines can be used on the operational floor

End-effectors: The V/HDS (tower cranes) is equipped with multipurpose conventional crane end-effectors. However, in order to guarantee a precise disassembly, new methods for on-site water and laser cutting are applied and tested.

System Variations: The installation of the SF and the CS do not require synchronization with the building's grid of columns. The subsystems can be installed to almost any building that allows the roof structure to be used as a platform for mounting the described subsystems. As the elements of the SF are orthogonal, the building should be orthogonal as well, in order to avoid major adjustments. The facade of the building waiting to be deconstructed should be stable enough for the application of the CS. Due to the use of tower cranes for pick-up and delivery to the ground, the creation of vertical shafts within the floor is not necessary.

ROD: To date, no building code or guideline exists, which, upon being applied, would simplify the use of QB Cut-off.

5.3.3 Ground Factory (fixed place) and Building Lowering

To date only one deconstruction system has been developed in this category. Kajima bases its deconstruction system on a reversion and simplification of the principle used in its automated construction system. The system is based on the idea of installing the main factory at the bottom of the building and to concentrate the main disassembly activities on the 5-10 floors which are closest to the ground. The building structure is, therefore, disassembled at the bottom and the building is lowered by computer controlled hydraulic presses, step by step. Compared to the previous categories, this system is faster (Kajima deconstructed three high-rise buildings in the middle of Tokyo within 3-4 months using the method) and the recycling rate achieved is higher (more than 90%). The higher deconstruction speed is due to the fact that the whole building serves as a factory shelter and that, in the 5-10 lower floors, disassembly can be prepared simultaneously so that when the materials reach the ground, the floors can be transported away JIT and JIS.

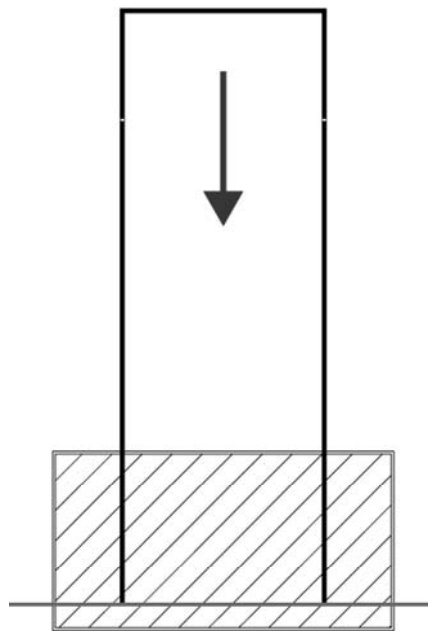

System Name	Company
30 Cut and Take Down Method "Daruma Otoshi" (DARUMA)	Kajima

However, the method also has major disadvantages. Due to a limitation of the power of the hydraulic presses, this method cannot be applied to super high-rise buildings. Furthermore, the lowering mechanism requires the bottom or basement configuration of the building to be suitable for the installation of the (relatively heavy and bulky) hydraulic presses, and that the building is based on a certain building typology (central core combined with an outward

column structure, main structure at best made of reinforced concrete). These requirements (height, bottom/basement configuration, building typology, and building material) considerably limit the application scope of the method compared to other methods (which can basically applied to any building).

Cut and Take Down Method “Daruma Otoshi” (DARUMA)

Company: Kajima Corporation, Japan

Category: Deconstruction - GF (fixed place) and building lift-down



On ground disassembly of lowered and prepared floors (Kajima, 2009)

Evolution Scheme: The Kajima's Cut and Take Down method (DARUMA) is named after the traditional Japanese game Daruma Otoshi. In this game several blocks are placed on top of each other like a tower and the player has to take out those wooden blocks one by one, starting from the bottom by using small hammer without causing the tower to fall down, so most of techniques, work and concentration are applied in the blocks at the bottom. From the description of this game, one can figure out the main idea behind Kajima's DARUMA. This traditional toy inspired Kajima's researchers and engineers into inventing a new high-rise building demolishing system which enables the cut-off of the ground floors, a computer controlled step-by-step lowering of the building and a systemic floor-by-floor disassembly of building components on ground level.

Elevation: The first and the only time the Kajima cooperation applied their DARUMA method was to demolish two out of the three towers at their former headquarters complex in Akaska-mitsuke, Tokyo. Consequently, the Kajima headquarters towers are the only example by which to describe this method. These towers were selected due to their steel structure, which made it easier to cut the columns and to replace them with hydraulic jacks, highlighting the first limitation of this method is that it can only be applied to high-rise buildings with full steel structures. The total working floors in this example was eight, one of them being underground, which is the "Jack control floor". Each floor had its own function, and in some case every two floors share one function. The jacks were installed on the ground floor. Outside the building, part of the ground floor was levelled up to be the same level of 1st floor. This raising was done to help the heavy machinery to reach demolishing floor.

Ground Plan: The demolishing floor shows the structure's load bearing grid and how the demolishing processes was done. Kajima's DARUMA method allows a building that is to be taken apart to retain its seismic and wind resistance capability by adding elements to the building structure. These elements are the first three listed under "Subsystems" below.

Subsystems: The Kajima Cut and Take Down method (DARUMA) consists of many integrated subsystems:

1. **Core Wall:** A temporary reinforced concrete structure located in the center of a building designed to absorb the potential horizontal forces generated by an earthquake.
2. **Load Transferring Frame:** Made of steel, this frame is set up where the core wall is enclosed. If an earthquake occurs, the core wall and the above-ground part of steel frame combine to provide earthquake resistance.
3. **Wedge Control Device:** Used to disconnect the core wall and load frame while the building is being lowered, and supplied with an earthquake early warning system.
4. **Hydraulic Jacks:**
 - Weight: three tons each
 - A lifting capability of 800 tons and a load carrying rating of 1200 tons each.

- Supporting plate with the ability to slide and rotate can be placed on top of the jack to absorb any horizontal and rotating movement.

These hydraulic jacks connect to the monitoring system, which is located in the control room. These systems monitor the working of the jacks and the working harmony between them, and in case of emergency or sudden movement this system can provide an emergency brake system to stop these jacks from working.

Process: The Kajima Cut and Take Down method (DARUMA) consists of a step-by-step process of demolishing:

1. Interior demolishing and recycling process: The "3 Rs" (reduce, reuse, recycle) is applied, which is the most effective process of reducing the waste. It is able to sort waste into 30 individual types of material for recycling, and into 20 types for conventional disposal. The waste materials can be easily and reliably stored on a floor-by-floor basis, making it easier for recycling facilities to plan ahead and to be efficient. The result of all of the above is a recycling rate of over 90 percent for the interior part of the building, compared to a rate of 55 percent achieved by conventional recycling methods. If one adds to that the recycling rate of the materials from the shell of the building (concrete debris and steel), the recycling rate jumps to 99 percent. One must also add to all of the above the method used by DARUMA to reduce significantly construction noise, airborne dust and dirt which in conventional construction usually disturbs the surrounding environment.
2. Floor functions:
 - 5th and 6th floors - interior demolishing and recycling: On these floors, the interior components which could be reuse or recycled are removed or demolished, such as wall portions, electrical and mechanical systems, tiles and flooring, plumbing systems.
 - 4th floor - asbestos demolishing: here the asbestos ceilings are removed and recycled.
 - 2nd and 3rd floors - cutting out the floors around the core wall.
 - 1st floor - demolishing floor: disassembling outer skin beams and concrete floor by heavy equipment.
 - Ground floor - jacks floor: Jacks are installed and columns are cut.
 - Basement - jacks control room floor
3. Columns cutting and demolishing cycle: When the columns are cut off (jack installation or cut and take down progress), the floor above tends to bulge somewhat, deforming and lowering by about 10 millimeters; the other columns should hold the load. The cutting progress is done in a precise sequence in order to avoid the floor above from deforming, and to distribute the load smoothly over the other columns. One demolishing cycle lowers the floor by 67.31 cm, which has to be repeated five times to complete

lowering one floor 3.75 m. It takes two-and-a-half days to do this plus three-and-a-half days for the demolishing process, so it takes six days to completely demolish one floor.

Step 1: Cut and take out the structure columns. Support the upper floor with big temporary columns near the structure columns.

Step 2: Take out the cut part of the columns and replace it with hydraulic jacks. These jacks will act as part of the building's structure.

Step 3: Complete the installation of the hydraulic jacks and connect them to the monitoring system, then remove the temporary columns. After step 3, the demolishing cycle starts.

Step 4: Cut 70 cm from the lower part of the structure's columns, which are attached to the upper part of the hydraulic jacks.

Step 5: Remove the cut part of the columns and support the floor above with temporary columns.

Step 6: Extend the hydraulic jacks until they close the 70 cm gap, making sure that the structure's columns are attached to the steel plate on the jack.

Step 7: Remove the temporary columns then lower the hydraulic jack, bringing down the upper floor until the demolishing floor has been reached (floor on floor). Disassemble the outer skin, beams and concrete floor.

End-effectors: The manipulators are equipped with multipurpose conventional end-effectors. However, in order to guarantee precise disassembly, new methods for on-site water and laser cutting are applied and tested. Furthermore, Kajima is currently developing methods of preparing concrete for efficient disassembly by very small, precise and targeted explosions (micro blasting).

System Variations: As the system does not set up a SF or GF structure, and as the main element (hydraulic jacks) can be placed under a column independent from the column grid structure, the system is highly flexible as far as the standard floor layout of the building is concerned. However, the method is limited in application to a certain type of concrete based building (buildings with a concrete column beam frame system and an inner core) and requires that the ground and basement levels of the building enable the placement of the hydraulic jacks.

ROD: To date no building code or guideline exists, which, upon being applied, would simplify the use of DARUMA. Even buildings constructed by Kajima's AMURAD might be difficult to disassemble using DARUMA if there is no inner core to stabilize the building during disassembly.

5.4 Efficiency Analysis

Based on the identification of parameters that determine or influence productivity, efficiency and overall economic performance in construction (**for further details, see 2.1**), an analysis framework that structures data related to the efficiency of integrated automated construction sites was set up. The analysis framework is based on the assumption that technical and economic efficiency are generated by both an efficient combination of input factors and the set-up of a high value product with a low defect rate. Individual performance parameters, such as work productivity, material efficiency, physical strain, health and safety, construction quality (related to the defect rate) and the integration along the value chain have been identified as the most influential construction performance parameters (**see 2.1**). Additionally, as outlined in **chapter 2**, the construction industry is highly labor intensive, with decreasing labor productivity, a high rate of construction defects, a high rate of fatal and non-fatal injuries and a relatively high amount of material input compared to the output value. This coincides with the low investment and R&D spending rate, the low capital stock and the low capital output ratio, indicating that the value and quality of the existing manufacturing equipment, process technologies and skilled workforce is low. However, integrated automated construction sites would require, for example, as in the automotive industry, a high investment and R&D spending rate, a high-level of capital stock, and thus of course demand for considerable improvements concerning the above mentioned performance parameters. The analysis in this chapter attempts to establish whether integrated automated site technology has the potential to deliver the demanded efficiency improvements. As the productivity, efficiency and economic performance of integrated, automated sites represents a complex scientific problem in itself, requiring direct comparison of data sets according to a specific framework, the analysis of this data set was decoupled from the more technical analysis in **5.2** and **5.3**. However, technical configuration of the systems and efficiency are symbiotic and thus closely related to each other. In most cases, positive or negative efficiency performance can be directly correlated to the general set-up, configuration, use of subsystems/end-effectors and the deployment of ROD.

5.4.1 Analysis Framework

The analysis framework was also synchronized with the currently available data sets. Parameters that companies deploying the systems did not analyze or make available (e.g. detailed data on investment or defects/errors, or injuries related to the application of the new technology) were not considered by the framework. The *Analysis and Categorization Matrix* shows which data were made available for each system. Obviously, companies that deploy their systems more often than others (Obayashi, Shimizu) also generate or are interested in generating more data sets. *Table 5-2* outlines the analysis framework and shows which parameters were considered as relevant for the efficiency analysis.

Table 5-2: Efficiency analysis framework

Thematic field	Parameters	Scope
Erection Speed	Project schedule	Time necessary to set up SF Operation period Time necessary for dismantling of SF Floor production rate per month
	FEC	Time and work steps necessary to complete a standard floor Parallel processing on several floors Equipment (e.g. OM) operation sequence
Configuration	Technical data speed of equipment	Operational speed of HDS Operational speed of CS Operational speed of VDS
	Experiments degree of automation/system configuration/ worker teams	Rate of automation – is installation operation remote controlled, partly automated or fully automated? Could companies apply system in various configurations (flexibility) Influence of varying numbers of workers e.g. on productivity
Productivity	Productivity workers/time (including comparisons with conventional construction or other systems)	Man hours required for completion of floor Number of construction workers required for specific task field Total number of workers Comparison with conventionally constructed buildings
	Learning effects	Reduction of time needed to install components with the novel site technology/equipment Reduction of time needed for welding Reduction of time required for FIL
Resource Efficiency	Material and resource efficiency	Reduction of required input material Reduction of construction waste generated

Quality, Health and Safety	Product or process monitoring (real-time progress, decibel etc., control room)	Real-time supervision of operations Real-time progress control, RTMMS Simulation of optimized operation
	Safety	Influence of environment on safety
	Physical strain (heart rate, etc.)	Influence of environment on physical strain
	Weather influence	Influence of weather on: <ul style="list-style-type: none"> • operation/task execution • productivity • quality
Usability Studies	Evaluation of usability of on-site factory and equipment by workers/operators	Influence on work tasks Influence on motivation Influence on feelings

5.4.2 Analysis According to Framework

The data used in this analysis were acquired from various sources, such as internal company project descriptions, publications by companies and their R&D staff, publications by researchers that analyzed systems, and by expert interviews with company staff. All presented data have to be considered from the perspective that all systems were still in an experimental and/or prototype phase. With the development of such technology, Japanese companies have aimed at long-term efficiency, and thus made a number of compromises concerning short-term efficiency. Obayashi and Shimizu, for example, who each deployed their systems in a multitude of construction projects (ABCS: 6 times; Big Canopy: 6 times; SMART: 6 times), introduced improvements in each new project, experimented with the configuration of the robotic crane systems or with the automation ration and the amount of workers used. Also, during the first projects using the SMART, Shimizu had the intention of training its workforce on the general use of the new technology (according to Japanese philosophy, knowledge about new technologies and tools has to be spread fast among the workforce by special training procedures), and thus replaced half the workforce with new workers from project to project in order to train as many of their workforce in using the new technology as fast as possible. Considering the fact that the learning effects within projects were enormous (see below), it can be assumed that this procedure influenced efficiency considerably, as it mitigated the impact of these learning effects across projects. Furthermore, most systems were still in a developmental phase, and did not fully utilize the capacity of their systems at any time during individual projects. Shimizu, for example, had up to 24 robotic trolleys available in a fully deployed SMART, but operated some projects with, for example, only ten of them.

Automated Building Construction System (ABCS) - Obayashi

With ABCS, Hybrid-ABCS and the Big Canopy, Obayashi applied three types of Automated/Robotic On-site Factories. ABCS represents the initially developed system and both Hybrid-ABCS and Big Canopy are variations of this system and its subsystems.

- ABCS: high ratio of systematization and automation, used for erection of buildings with steel frames
- Hybrid-ABCS: combination of conventional construction with ABCS, used for erection of buildings with steel frames
- Big Canopy: variation and recombination of ABCS technologies, used for erection of concrete buildings

Obayashi captured a tremendous amount of data during the operation of all three systems, and, on this basis, analyzed the impact of productivity, efficiency, working conditions and building quality.

Rough Project Schedule: ABCS, and its variation the Hybrid-ABCS, have been used a total of five times commercially (**Ikeda & Harada, 2006**):

- Project 1 (ABCS): 10 floors, 650 m² per floor, 8 floors were built by the system
- Project 2 (ABCS): 26 floors, 2700 m² per floor, 19 floors were built by the system
- Project 3 (ABCS): 33 floors, 1100 m² per floor, 26 floors were built by the system
- Project 4 (ABCS): 37 floors, 2700 m² per floor, 30 floors were built by the system
- Project 5 (Hybrid-ABCS): 22 floors, 3650 m² per floor, 18 floors were built by the system

Projects 3 and 4 showed, in particular, that the actual construction time, including interior finishing by ABCS, could be reduced to nearly six months, which, considering the amount of floors erected in these projects, is an extremely short amount of time. The reduction of construction time during these projects is even more remarkable considering the fact that the system was still in a state of optimization and improvement, and that during each application Obayashi experimented with new configurations of the system, so that learning effects across projects could not have been deployed fully. It turned out that general planning, and execution planning in particular (which can be largely related to the planning of the application of ABCS), took more time than is usual in conventional construction, due to the use of ABCS. In conventional construction, general planning, and execution planning in particular, are often both partly parallelized with the construction process. As ABCS cannot be operated fully in the lower 2-4 floors and top 1-3 floors, but only in those in between, the number of floors that can be constructed by ABCS is always lower than the total number of floors by a certain amount. Related to the total amount of floors in the building that ABCS allows, is the fact that buildings are constructed at a speed of three floors (buildings with larger floor areas) to four floors (buildings with smaller floor areas) per week.

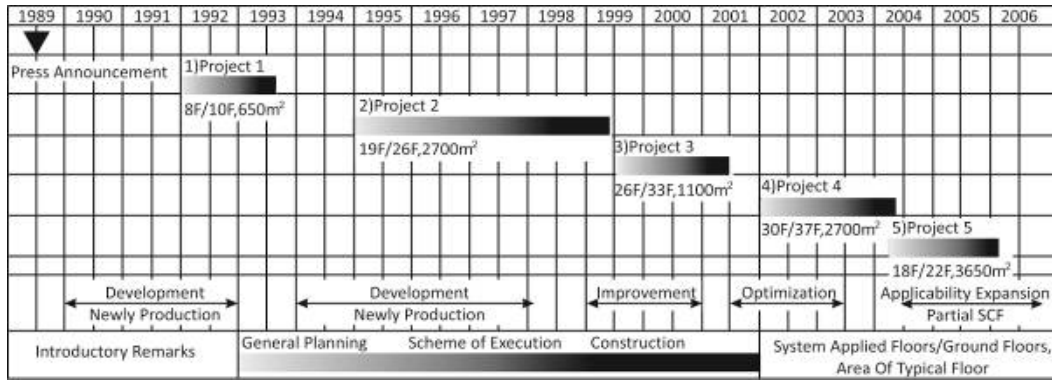
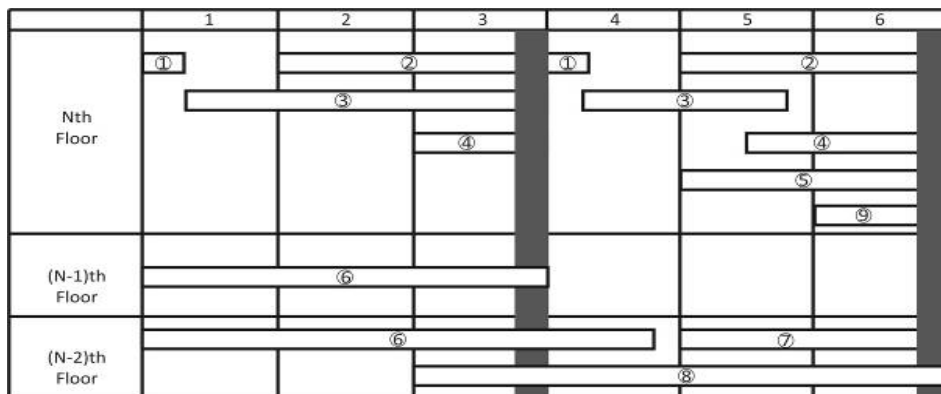

Figure 5-1: Comparison of time needed by different ABCS applications in various projects (Ikeda & Harada, 2006)

FES: FES of ABCS follows a six day schedule. Work is done on several levels in parallel. On the uppermost floor (n th floor) in the SF, the steel frame erection is done by the automated OMs for the middle column row. At the same time, the two automatic OMs operating from the outer column rows install exterior facade elements on the lower levels ($n-2$ floor). After three days, the middle column row is completed and the SF can be lowered by 70 cm in order to rest statically on those columns. The outer column rows can then be built. As the SF enables work on the facade (installed on $n-1$) on $n-2$ to take place from the inside and outside of the building, on a safe and enclosed working platform, the facade on level $n-2$ is sealed and finished completely within the SF. Interior finishing is then done on the lower floors of the (sealed) building.



- (1) Column erection; (2) Column welding; (3) Beam erection; (4) Precast concrete element installation; (5) Deck packing; (6) Exterior precast concrete panel installation; (7) Glazing; (8) Calking; (9) Material climbing; (10) SCF lowering (700mm); (11) SFR climbing

Figure 5-2: FES for standard floor and with system in full operation (Miyakawa et al., 2000)

Experiments with Degree of Automation / System Configuration / Worker Teams: During the application of ABCS in various projects, Obayashi experimented with different automation ratios. The experiments, following the optimum principle, tried to find an optimal relation between a certain automation ratio and the output performance. The experiments focused on the automation of the OMs and the welding system (**Miyakawa et al., 2004**):

- **Operation of OMs in SF:** In some projects, the OMs were operated automatically only at a location close to the installation location and final positioning was done manually by remote control. In other projects, the whole logistics and positioning process of VDS and HDS was automated. It turned out that the first approach was more cost effective, as faster operation was possible. Full automation turned out to be slower due to real-time processing of localization, motion planning, fusion of sensor data, etc.). Furthermore, the first approach needed less effort for programming and was less error prone.
- **Welding Operation:** Within the ABCS applications, Obayashi conducted experiments with welding robots. Welding robots turned out to be slow and in need of continuous supervision. Additionally, they could only be used for simple welding operations (e.g. straight line around column). Human welders were faster in conducting simple welding operations. For more complex welding operations they were, however, a necessity.

Productivity: Compared to conventional construction, ABCS is able to reduce the average labor requirement (man hours) per floor by around 40%. Reductions are possible in nearly all work categories. High reductions of man hours have been achieved regarding the positioning of steel frame elements (steel columns and beams), floor installation work and the installation of safety facilities. The application of ABCS has also created new work categories on-site.

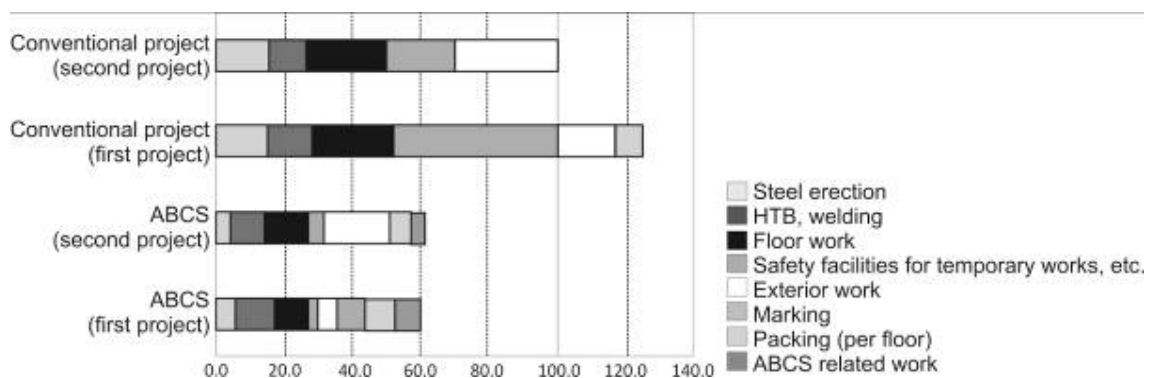

Figure 5-3: Comparison of unit labor requirements per floor area (**Miyakawa et al., 2000**)

Learning Effects: Obayashi has found that within task categories the time necessary to complete a task in average during the project decreased by 10% (**Miyakawa et al., 2004**).

Product Quality and Process Monitoring: To be able to survey and record all construction operations, and thus to guarantee the quality of the final product, ABCS uses an on-site control center with the following capabilities:

- Surveys equipment operation in real time (cameras, sensor data, motor data) – visual real time representation of equipment operation
- Barcode system manages material during delivery, logistics and positioning process
- Determines order of assembly
- Controls work schedule and supply of material
- The system reduced the need for on-site construction management and conventional quality control methods.

Safety: ABCS improves the physical strain, health and safety of the workforce (**Miyakawa et al., 2004**):

- It provided safe working platform for workers. As ABCS always creates a full floor, including floor slabs (in steel building erection, the frame was often firstly completely erected). The lower floor always serves as a safe working platform during steel column and beam assembly (e.g. welding operations).
- Safe working platforms for outside facade work are provided by the SF (no scaffolding necessary)
- The OM operators sit in the SF with a view over the whole area, and are thus able to work close to the installation location. This enhances accuracy and safety, improves teamwork and reduces the possibility of injuring someone by the OM or during material lifting.

Usability: During application of ABCS, Obayashi conducted usability studies and analyzed how the system influenced the worker's behavior, feelings and motivations related to the system (**Miyakawa et al., 2000**). The study also compared different categories of workers. In general, the workers evaluated ABCS more positively than negatively (most ratings were above average). However, the study also revealed that the systemized ABCS environment made workers think that it is more difficult to take a day off (thus many reported feeling fatigued). Furthermore, the lighting and the bright working environment in the ABCS SF was not evaluated positively. All in all, it can be surmised that the systemized ABCS, from a worker's point of view, obviously reduces the room for breaks and individual work speed, it changes the habits of the construction workers, and as the usability studies have shown, is not viewed positively in all aspects. This phenomenon accompanies many new developments that involve technologies that are able to track or record people and processes.

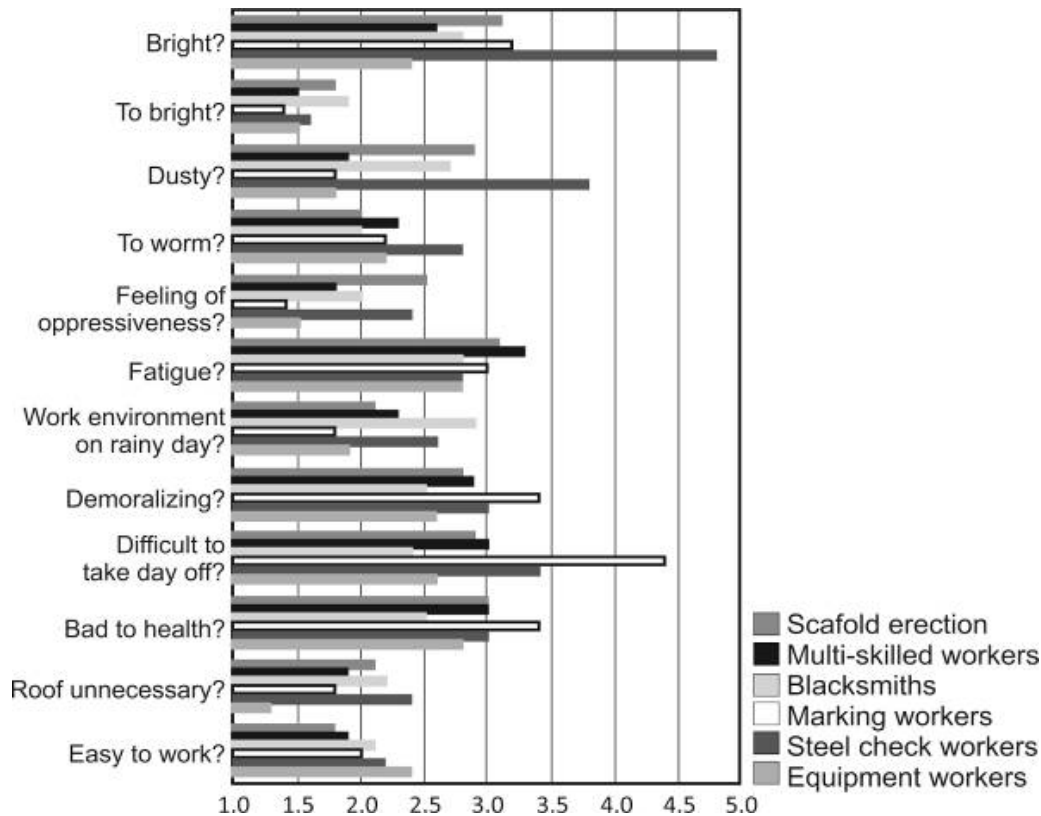

Figure 5-4: Rating of usability of features of sky factory approach. Comparison of rating of various classes of workers compared; a rating of 5 indicates negative opinion, whereas a rating of 1 indicates a positive opinion (Miyakawa et al., 2000)

Hybrid Automated Building Construction System (Hybrid-ABCS) – Obayashi

The Hybrid-ABCS combines ABCS and conventional construction with the aim of combining the advantages of both methods and to achieve higher efficiency. The Hybrid ABCS uses a central part of the building for the erection of the ABCS, and conventional labor based assembly is used for the erection of the rest of the building. The central ABCS is also used to supply the conventionally constructed part with material. If ABCS was used for the whole building, the necessary long travelling distance of the automated – and not particularly fast – ABCS OMs would slow down construction (the building in Project 5 was very broad concerning its ground plan). By using both ABCS and conventional methods in parallel, both can operate simultaneously and nevertheless create synergies (e.g. logistics).

Rough Project Schedule: For Obayashi, the Hybrid-ABCS represents an extension of the capability of ABCS. Its application in Project 5 (see diagram 5-7 below) was the beginning of a development in which Obayashi started to use ABCS elements along with conventional construction. After successful completion of Project 5 (see diagram 5-7 below), Obayashi even went one step further and started to use individual ABCS subsystems (e.g. only an

automatic lift) in projects where predominantly conventional construction was applied (e.g. Tokyo Sky Tree). Today, Obayashi does not apply the full ABCS any more but rather its individual subsystems. It is remarkable that by applying the Hybrid-ABCS for the first time, Obayashi was able to completely construct a building with an average size of 3650 m² per floor, and 22 floors within six months (actual on-site construction time).

FES: During the application of the Hybrid ABCS, Obayashi experimented with both five-day and six-day cycles for completion of an average floor. As the six-day cycle was the norm, the experiments showed that a five-day schedule was possible. The schedules showed that the application of ABCS and conventional construction methods (CCM) in clearly defined parts of the building allows for parallelization of work.

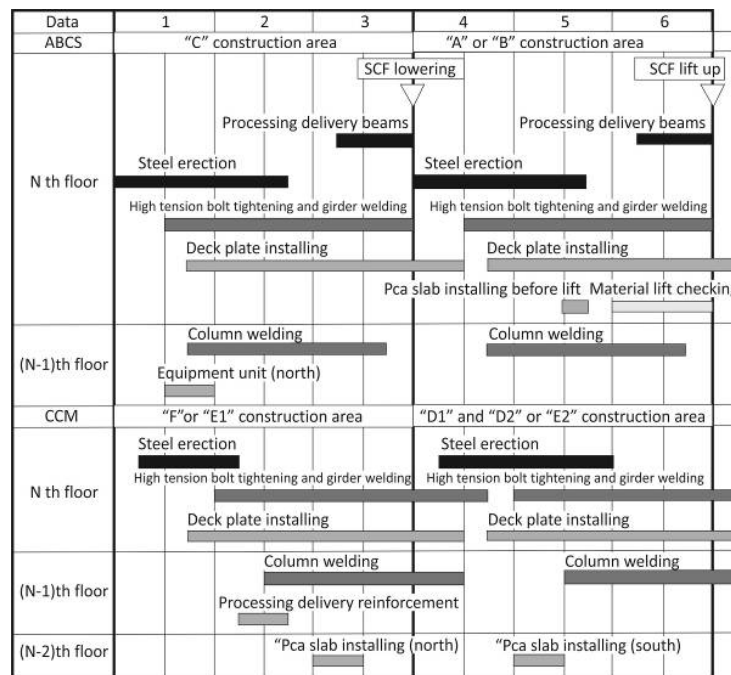

Figure 5-5: Standard schedule (six-day process) (Ikeda & Harada, 2006)

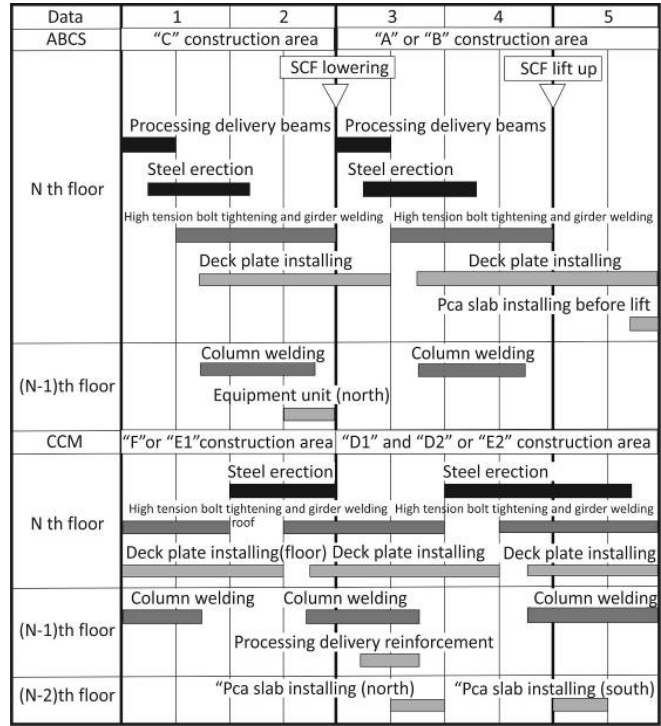

Figure 5-6: Shorter schedule (five-day process) (Ikeda & Harada, 2006)

Productivity: The Hybrid-ABCS was able to reduce the requirement of human labor (man hours/m²) by more than 10%, compared to ABCS. Compared to conventional construction, ABCS had already reduced the requirement of human labor by about 40% (see above ABCS).

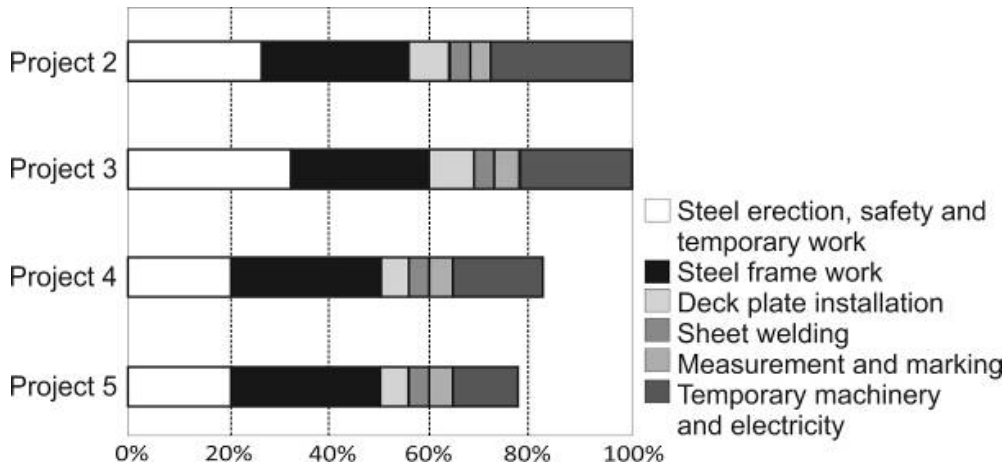

Figure 5-7: Comparison of labor requirement per floor area (Ikeda & Harada, 2006)

Learning Effects: Obayashi recorded the time the workers needed to complete the welding operation on each floor (**Ikeda & Harada, 2006**). The number of welding operations on each floor was basically the same. The learning effect within the project was enormous, and the time needed to complete the welding tasks was brought down from 120% (4th floor) to less than 40% (20th floor).

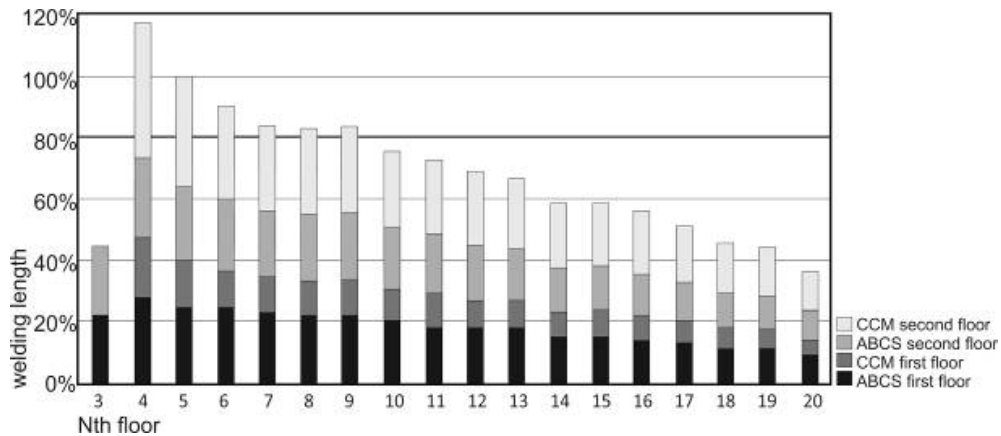

Figure 5-8: Welding Length (**Ikeda & Harada, 2006**)

Big Canopy – Obayashi

In order to reduce complexity on-site, Big Canopy processes prefabricated concrete components on-site. The building is thus divided into a kit of concrete components (walls, beams, columns, ceiling/floor elements, balcony elements). The rate of prefabrication accounted for 71% of the concrete volume.

Detailed Project Schedule: Big Canopy is able to erect concrete based buildings. In the example of an erected building, given in *Figure 5-9*, the erection of the whole building including excavation and final finishing work took just over two years (25 months). The Big Canopy system was applied from the 3rd floor to the 27th floor. It was able to construct 24 floors in nine months, which is the equivalent of 2.7 floors per month, on average. The set-up of the Big Canopy system took around one month, and the dismantling also one month.

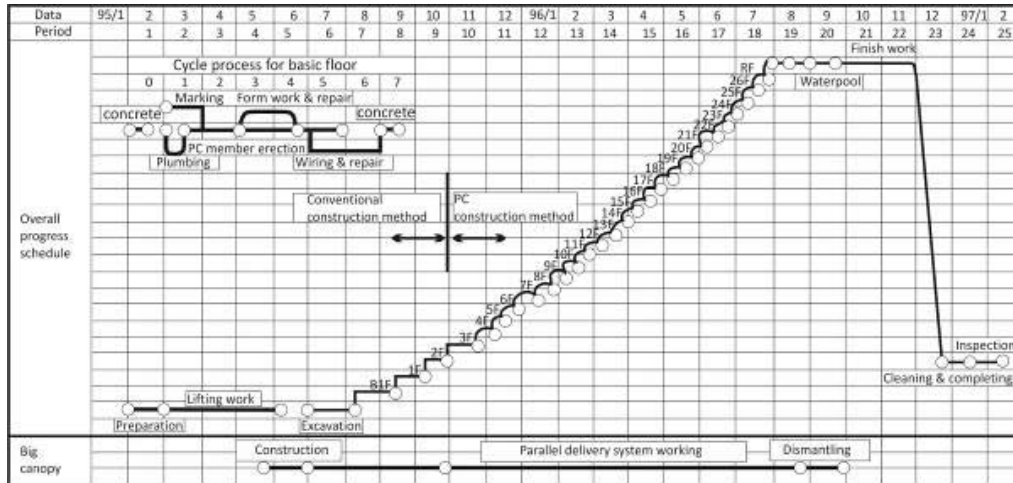

Figure 5-9: Overall progress schedule and cycle process for a basic floor (Wakisaka et al., 1997)

FES: With Big Canopy, in the example above, floors were erected on a six-and-a-half day cycle. It started with plumbing work on top of the previous floor, and then the prefabricated concrete elements were installed. In parallel, in areas where the concrete elements had already been placed on a floor formwork, wiring and rebar work took place. At the end, a phase followed whereby on-site concrete was used to complete the floor.

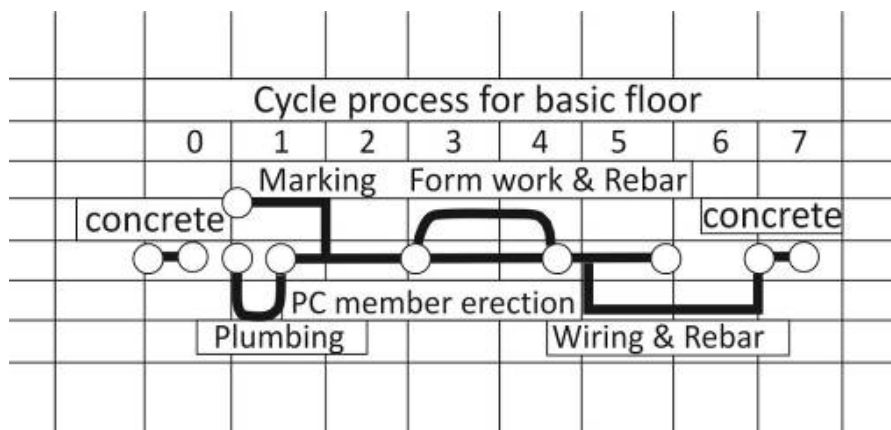

Figure 5-10: FES (Wakisaka et al., 1997)

Technical Data, Speed of Equipment: In the above example, the main contributors to the elements' delivery and positioning speed were an automatic lift, the delivery OM, two erection OMs and set of three travelling hoists. The travelling speed of all equipment was

between 30-40 m per second. The OM system could be operated manually (remote controlled) and was completely automatic.

Table 5-3: Specifications of parallel delivery system (Table according to **Wakisaka et al, 1997**)

Name and number of device	Specification
Construction Lift 1	Loading Capacity: 6 t Winching up Speed:40 m/min Control Type: Inverter
OM used for Hoist Delivery	Operation Type: manual/automatic wireless remote-control Control Type: inverter
Delivery OM 1	Maximum Travelling Speed: 40 m/min
Erection OM 2	Suspended Capacity: 7.5 t
Erection Hoist 3	Maximum Travelling Speed: 30 m/min Suspended Capacity: 7.5 t Maximum Travelling Speed: 33 m/min Suspended Capacity: 7.5 t
Gyroscopic Suspender	Operation Type: wireless remote-control Weight: 1100kg Rotating Drive: Gyroscopic Moment Inertia Moment of Load: 25 tons/m

Experiments with Degree of Automation / System Configuration / Worker Teams: Obayashi experimented with running Big Canopy in manual in automatic control modes. The analysis of the experiments shows that the manual operation is 5-10% faster. However, automatic control reduces the need for a supervisor and thus saves man hours.

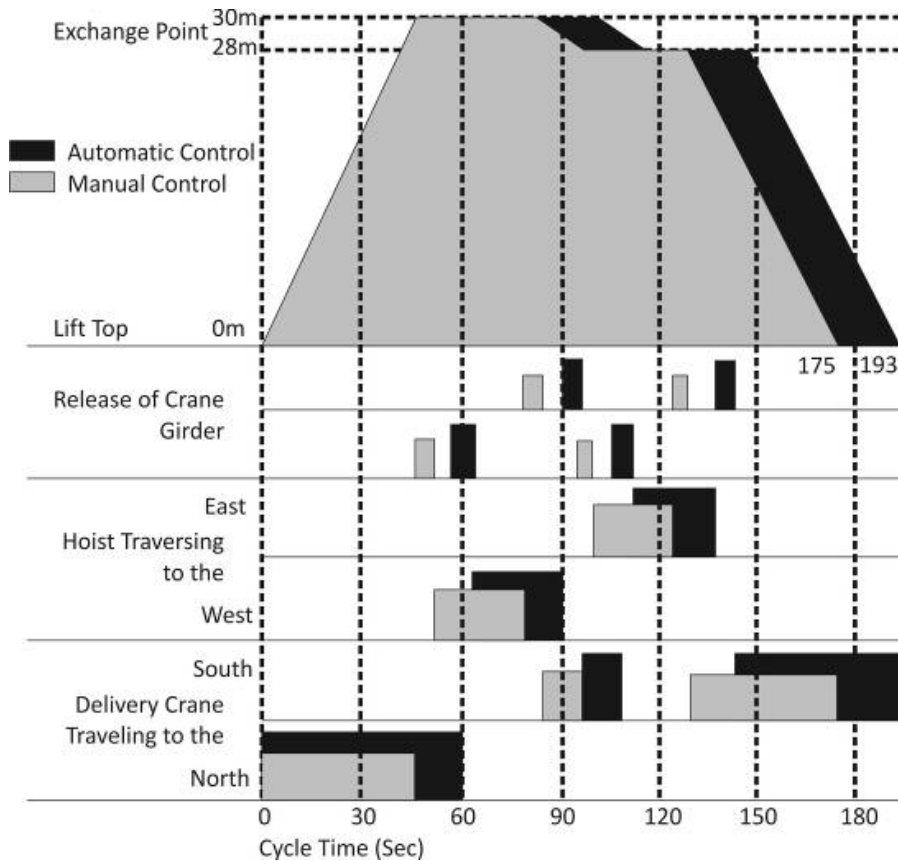

Figure 5-11: Comparison of the cycle time between automatic and manual control systems (Wakisaka et al., 1997)

Productivity: Big Canopy is able to enhance labor productivity (on average) by around 70% compared to conventional construction. The labor productivity improvement, compared to conventional precast concrete construction, is around 10%, and compared to construction with formwork systems it is 40%. Compared to conventional construction, Big Canopy particularly reduces the labor required in steel bar and formwork work. Compared to conventional precast concrete construction, Big Canopy significantly reduces the amount of work related to the installation of the concrete elements. Furthermore, comparisons have shown that Big Canopy is faster at erecting a building than two tower cranes.

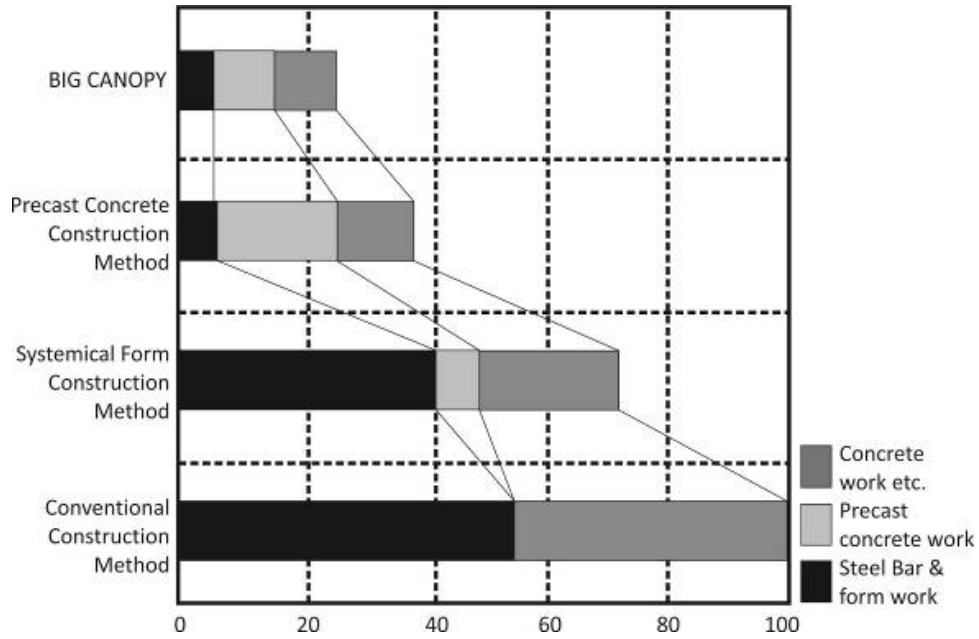

Figure 5-12: Productivity comparison of four construction methods (Wakisaka et al., 1997)

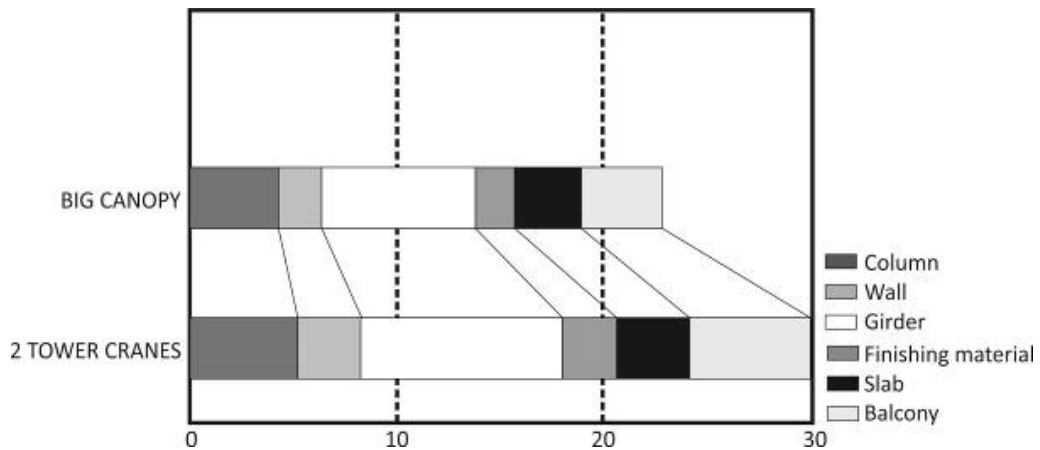

Figure 5-13: Efficiency comparison between two tower cranes and parallel delivery systems (Wakisaka et al., 1997)

Learning Effects: Analysis of the number of workers and man-hours needed to complete a standard floor within a Big Canopy SF shows that through learning effects, improvements to the main work tasks assisted by the system (floor slab installation, balcony element installation, column component installation, wall component installation and beam/girder installation) of up to 20% less workers/floor are possible. Considerable improvement starts from the tenth floor.

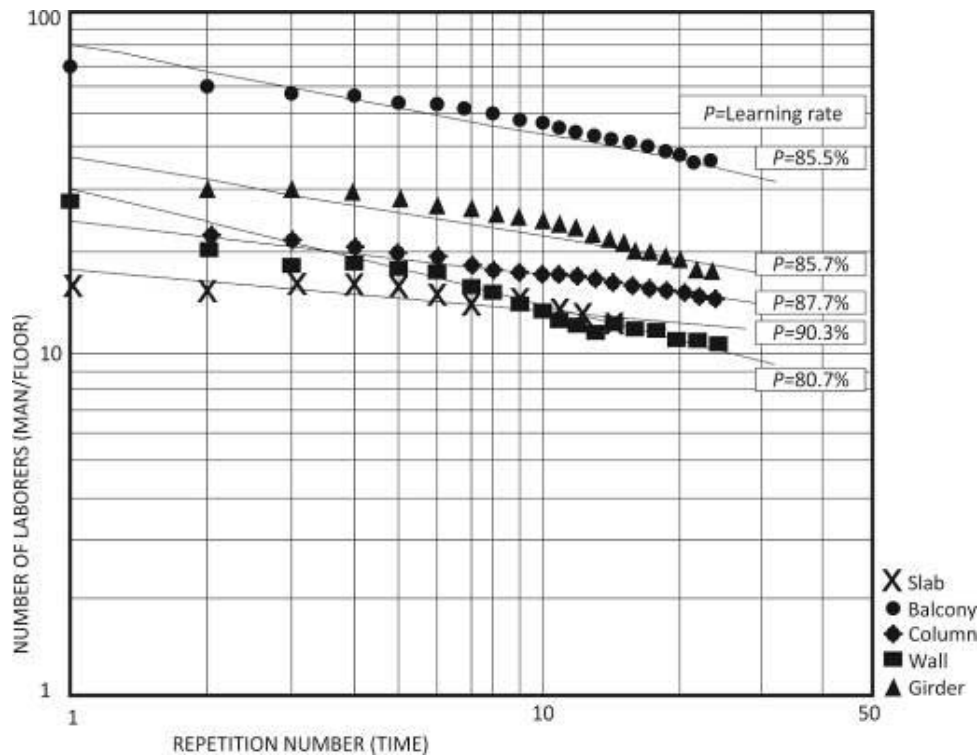

Figure 5-14: Comparison between numbers of laborers (man/floor) regarding the time needed (Wakisaka et al., 1997)

Product Quality and Process Monitoring: In order to find an optimal sequence of logistics and installation operations conducted by Big Canopy’s subsystems (for example VDS and HDS), a transport cycle-time simulator is used in advance of each construction project. An RTMMS allows the generation and supervising of material flow and work tasks. The RTMMS consists of following subsystems:

- Material Plan Subsystem
- Material Management System
- Actual Management System
- Erection Site Management System

The RTMMS has similarities to, for example, Enterprise Resource Planning systems (EPRS) common in the manufacturing industry. It allows the setting up of material flows and work tasks as well as the control of the progress of the assembly. As all materials are tagged (barcoded), the flow of material, as well as all assembly operations executed by Big Canopy and workers become transparent and allow for a more or less real-time control of the construction progress and construction quality.

Safety: The modification of the working environment enhances both safety and productivity. Obayashi conducted studies on how the temperature influences productivity on-site. Japan

is a country where, especially in summer, it is hot and humid. Homes, offices and factories are usually equipped with climate regulation systems to mitigate the influence of the temperature. By erecting a temporary roof over the site, Big Canopy also tries to mitigate the influence of temperature.

Figure 5-15 analyzed a standard building constructed by Big Canopy and shows that both the workers and the materials (such as reinforcement) were protected from overheating through exposure to sunlight. Obayashi further calculated that during the measurement period from July to September (123 days), the temperature reached over 30°C on 66 days at conventional sites with no protecting roof and accounted for about 50 hours (equivalent to 6.3 working days) of lost working time, equivalent to an overall decrease of productivity of 10%. Big Canopy, and other systems with a protective roof, can reduce this type of productivity loss to practically zero. Furthermore, the reduced temperature also decreases both the mental and physical strain the worker is subject to, enhancing concentration and thus safety and quality.

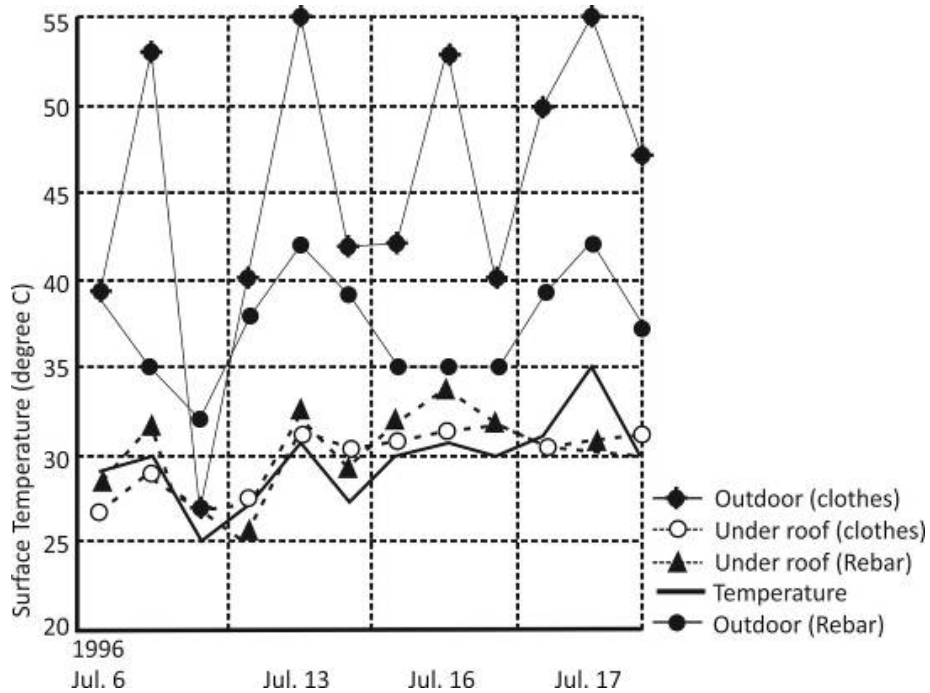

Figure 5-15: Surface temperature of workers' clothes and reinforcement (Wakisaka et al., 1997)

Physical Strain: In order to analyze the physical strain workers are subject to in conventional construction environments and in the Big Canopy working environment, Obayashi measured the heart rate of workers.

Heart rate figures of workers on conventional non-covered construction environments:

- Maximum: 134 beats/minute

- Mean value: 103 beats/ minute

Heart rate figures of workers in the Big Canopy working environment:

- Maximum: 108 beats/minute
- Mean value: 89 beats/ minute

According to Obayashi, in conventional construction the heart rate was 80%/40% higher than that measured during breaks. On the Big Canopy site it was only 20% to 40% higher.

Influence of the Weather: Besides the above mentioned influence of the sun and temperature on the construction process, Obayashi analyzed the influence of wind on the construction process. Obayashi continuously measured the wind's strength (measured in minutes) during Big Canopy's application (precast concrete element positioning for standard floors). Obayashi found out that during Big Canopy's application, the wind speed exceeded 10 meters/second for 87 working hours, equivalent to 12 working days. A wind speed of 10 meters/second usually means that tower cranes cannot be operated (strong wind hours). Big Canopy reduced wind speed related down-time to 1.5 days. The Main reasons for this reduction are:

- Big Canopy roof structure reduces wind speed by 2/3
- The lift is not subject to the wind
- Compared to conventional construction, the OMs hoist cable ropes are relatively short.

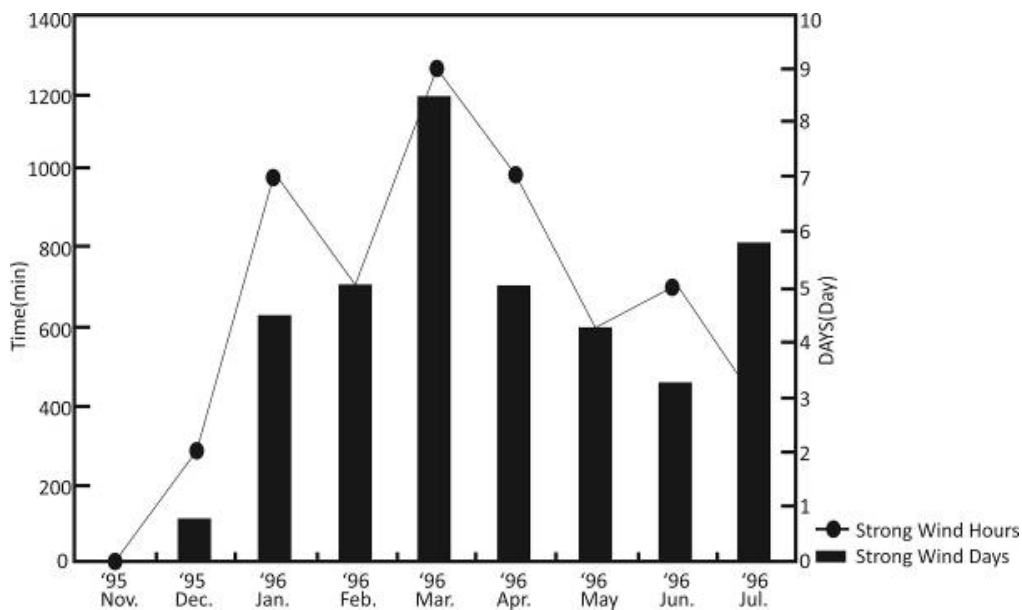

Figure 5-16: Wind flow measurement (Wakisaka et al., 1997)

FACES - Goyo

FACES is used to erect steel based buildings. The on-site factory that operates on top of the building is characterized by the two powerful OMs (by Goyoy also called “shuttle cranes”). After several applications, the system shows both advantages and disadvantages. One advantage is that the two powerful and heavy OMs are able to manipulate and position heavy elements with high precision (with higher precision than the OM systems of SMART and ABCS, for example). A disadvantage is the low operating speed of FACES’s OMs and the strong vibrations their operation creates. Furthermore, due to the reliance on the two powerful OMs, the system is less flexible and adaptable to varying structures and shapes of building than, for example, the SMART that, due to its composition of small gantry OMs and travelling trolley hoists, allows a higher variety of configurations.

Detailed Project Schedule: The time schedule for the erection of a building with 23 floors in the Nihonbashi area in Tokyo by FACES:

- **Set-up:** The set-up of FACES took, in total, around 5 months for the project in the figure below. The long period was due to the fact that this project was the first application of the system and included the time necessary to certify the operational safety. Later, the time needed to set up the system was reduced to 1-2 months. Nevertheless, in all projects, as FACES took over operation from the 3rd floor, the basement work and the erection of the 1st and 2nd floors could be done in parallel to FACES set-up.
- **Operation:** The system was able to erect in 23 floors over eight months, or the equivalent to two-and-a-half floors per month.
- **Disassembly:** The disassembly of the FACES took one month. During this time other finishing work took place.

During the phase where standard office floors had to be erected, FACES reached a maximum speed of three floors per month.

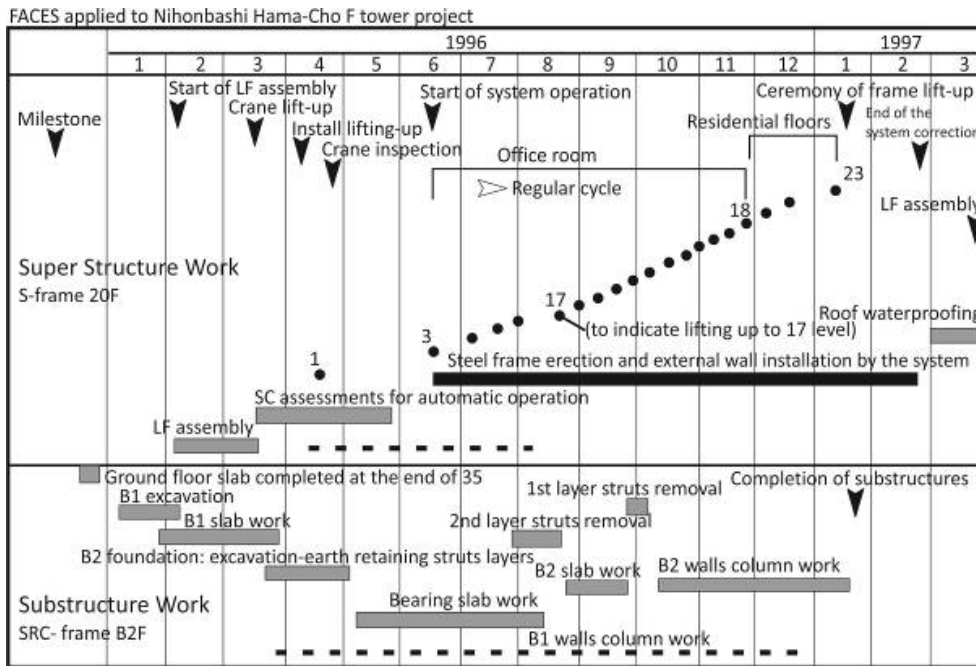

Figure 5-17: Work schedule (Yoshida et al., 1997)

FES: In the above example, FACES worked with a FES of six days, meaning that the site factory was raised every six days. FES of FACES includes parallel processing on four floors (n th, $n-1$, $n-2$, $n-3$). The n th floor refers to the uppermost floor close to the OMs. Floors $n-1$ to $n-3$ are the floors below this uppermost floor. The figure below shows that the schedule was built around the OMs operations. The two OMs of FACES take over the transport and positioning of heavy and large sized elements, such as the steel column, beam structure and the facade elements.

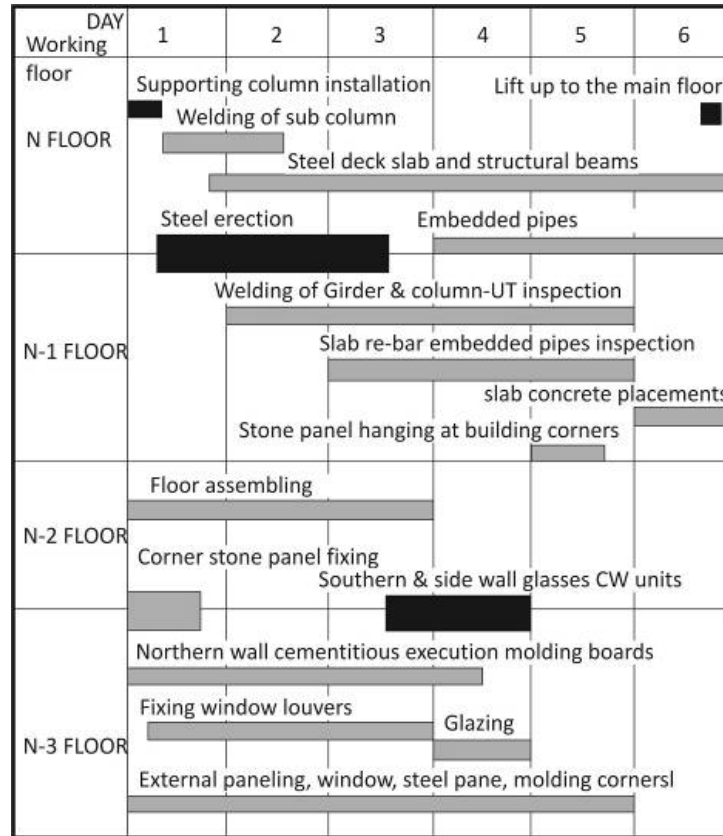

Figure 5-18: Cyclic procedure of construction work (Yoshida et al., 1997)

Technical Data. Speed of Equipment: The OMs are the central element of FACES. Each OM has 5 DOFs, including prismatic and rotatory joints. Compared to other systems (e.g. Big Canopy or SMART with 30-40 meter/minute for gantry OMs and hoists) travelling and rotatory speeds are lower (20 meters/per minute). However, FACES's OMs are able to pick up and position several elements within one working procedure, thus reducing the need to travel long distances.

Table 5-4: OM specification (Yoshida et al., 1997)

Rated suspension load: 10 t	Travelling speed: 20 m/min
Boom turning radius: 6-10 m variable	Boom shuttle speed: 20 m/min
Lifting height: 120 m	Booming turning speed: 0.5 rpm
Lifting/lowering speed: 10 t, 38m/min	Hook turning angle/speed:
5 t, 50m/min	Front: 90°/0.5 rpm
No load, 70m/min	Creep mode: 7% speed operation

Two-hook independent hoisting-lowering speed/stroke : 0.45 m/min with a stroke of 0.5 m

Experiments with Degree of Automation / System Configuration / Worker Teams:

Experiments concerning an optimized ration of automation were conducted during the operation of FACES in the first projects. Different types of work were conducted in manual operation mode (remote controlled) and executed automatically by FACES's subsystems. The times needed to complete the work or tasks were recorded and compared.

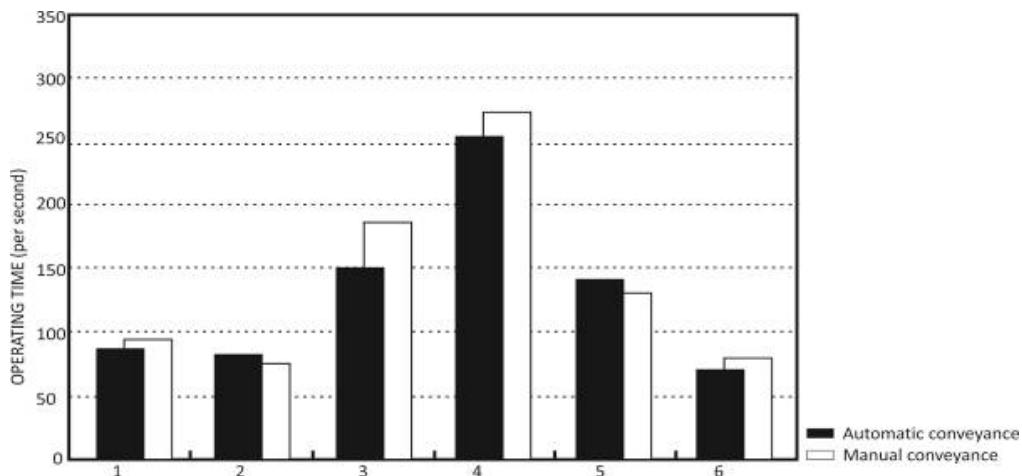

(1) Hanging something from a OM etc. (2) Rolling something up (3) Conveying to another level (4) Installing and lifting up (5) Collecting something (6) Rolling something down

Figure 5-19: Comparison of Automatic/ Manual Conveying Time (graphical representation according to Yoshida et al., 1997)

Productivity: FACES in the first projects was able to improve labor productivity considerably for work tasks that are usually work intensive. Analysed work task fields saw an increase in productivity by two to six times. Additionally, the improvement of work processes related to facade work in particular was able to improve quality of construction and reduce the risk of injury.

Table 5-5: Labor-saving result (Table according to **Yoshida et al., 1997**)

Working location (standard floor)	Efficiency of conventional methods	Efficiency FACES	Labor-saving factor at site
245 m²	Knock-down system	Full unit system	
Toilet room	2-3 m ² /man-day *	12 m ² / man-day	1/4-1/6
19 m ² , 23 m ² rooms	Conventional method	System toilet unit	1/4
Moulding board installation	64 men/ standard floor	15 men/ standard floor	
164 m²	Non-scaffold method	Exterior scaffolding work at the side shelter (FACES)	
Exterior sealing	3-4 m ² /man-day	6.4 m ² /man-day	2/3-1/2
Glass Curtain wall	Using gondola 15 m ² / man-day	Exterior scaffolding work at the side shelter (FACES) 40 m ² / man-day **	1/3

* Frame assembly only, not inclusive of glazing and sealing work.

** Included instalment of water drainage pipes in 40 positions inside seals

Product Quality and Process Monitoring: FACES deploys a RTMMS that can help to set up and supervise material flow, work tasks and processes. Manual control over the equipment can be executed via a computer. Automatic operation can also be supervised in real time. The information system links an off-site planning office with an on-site office, material handling yard and the central control room at the FACES construction factory on top of the building. The system also allows the acquiring of data about completed work tasks on working and finishing floors (n th, $n-1$, $n-2$, and $n-3$).

AMURAD – Kajima

Kajima uses its AMURAD system to erect concrete based buildings with up to 20 floors. In contrast to other systems, AMURAD installs the SF on the ground. Rail-guided robots position the concrete elements on the ground and hydraulic presses push up the completed floored. In parallel, interior, plumbing and finishing work is done on the upper floors.

Detailed Project Schedule:

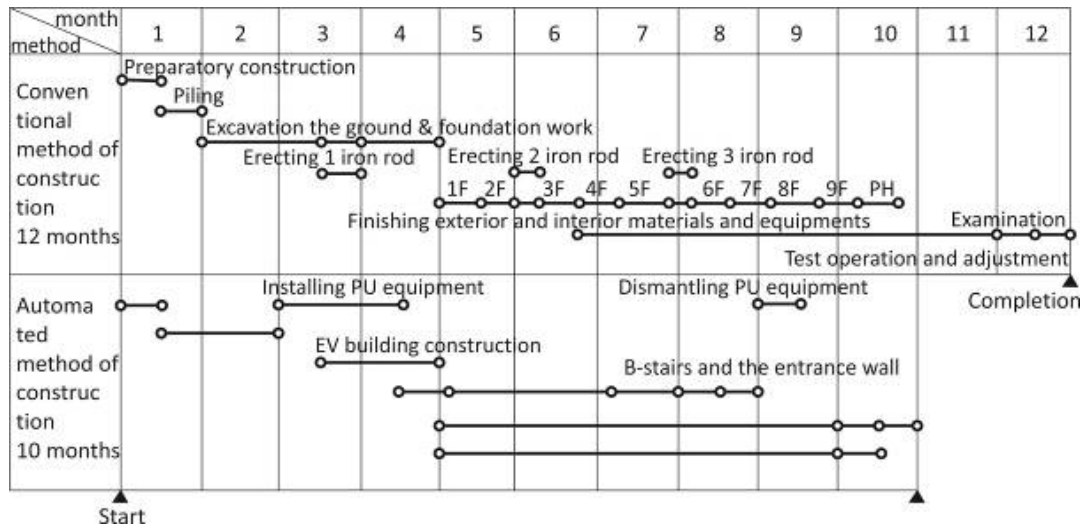

Figure 5-20: Example of automation for construction (construction period comparison) (Sekiguchi et al., 1997)

FES / Work Sequence: In the example push-up operation, the weight of the building was firstly transferred to the column bearing bases. At this point the push-up machine was in an unloaded state. Next, the arm was extended outside the building and lowered down one floor while avoiding the girders. Then, the arm was retracted and leveling and adjustment was completed; it re-assumed the load of the building and raised the building up to the required height (one floor up). The stroke length for one floor was 3.2 meters, and it ascended at a speed of 15 mm/min, requiring three-and-a-half hours to perform the lift.

Floor	Construction	Day1	Day2	Day3	Day4	Day5	Day6
5	Finishing	Floor Finishing				Furnishing	
4	Equipment interior materials	Fitting up partition panels			Finishing interior materials	Fitting up equipments	
3	Exterior materials	Unit duct	Unit wiring		Fitting up the system ceiling		Fitting up handrails
2	Building Frame construction	Fitting up the balcony		Fitting up the exterior walls		Fitting up doors and windows	
1	Fitting up building Frame			Fitting up ducts	Concrete of floor	Concrete of walls	Form work dismantling
		Fitting up posts and joists	Fitting up floor boards				



Figure 5-21: Process cycle for six days (Sekiguchi et al., 1997)

Technical Data, Speed of Equipment: The main equipment of the AMURAD can be operated manually (remote controlled) and automatically. The maximum operation speed of the subsystems:

- Z-Up: 10 meters/minute
- Z-Carry: 10 meters/minute
- Z-Hand: 10 meters/minute

Table 5-6: Specification of Z-Up, Z-Hand and Z-Carry (Hasegawa, 1999)

Item	Specification of Z-Up	Item	Specification of Z-Hand	Item	Specification of Z-Carry
Ability to push up	400-600 tons	Weight of Loading	5 tons	Ability to push up	1.3 tons
Outline dimensions	B2.700XW4.00 0XH6.000	Outline dimensions	L5.500XW3.50 0XH2.425	Outline dimensions	L4.500XW1.400 XH1.660

Weight of equipment	About 50 tons	Weight of equipment	About 8 tons	Weight of equipment	About 5 tons
Pushing up mechanism	Electric clinchers and nuts	Ascent stroke	2.069 m	Pushing up mechanism	At most 10 m/min
Stroke	3.250-3.950 mm	Moving velocity	15 m/min	Stroke	Automatic moving
Ascent velocity	15 mm/min 40 mm/min (without load)	Operating method	Wireless remote control Joystick	Ascent velocity	Inverter
Tolerance	0.1mm	Moving method	Rail	Tolerance	Rail
Engine	AC 400V, 10 pieces of equipment's use 254kw	Engine	AC 400V, (30kw each)	Engine	AC 400V, (30kw each)

Productivity: The AMURAD was in the first projects was able to improve work productivity by more than 20% (measured by man days/per m²) compared to conventional construction of comparable buildings. The highest reduction of human labor (nearly 50%) was in relation to the erection of the building's concrete structure (structural member).

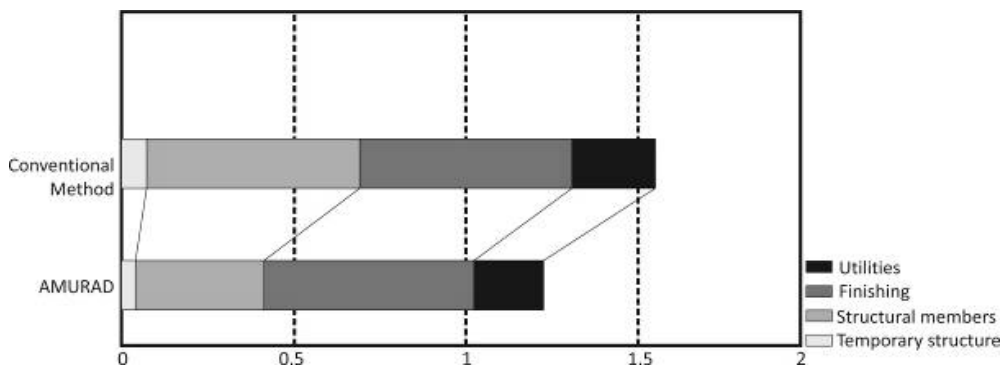

Figure 5-22: Construction work production rate comparisons (Sekiguchi et al., 1997)

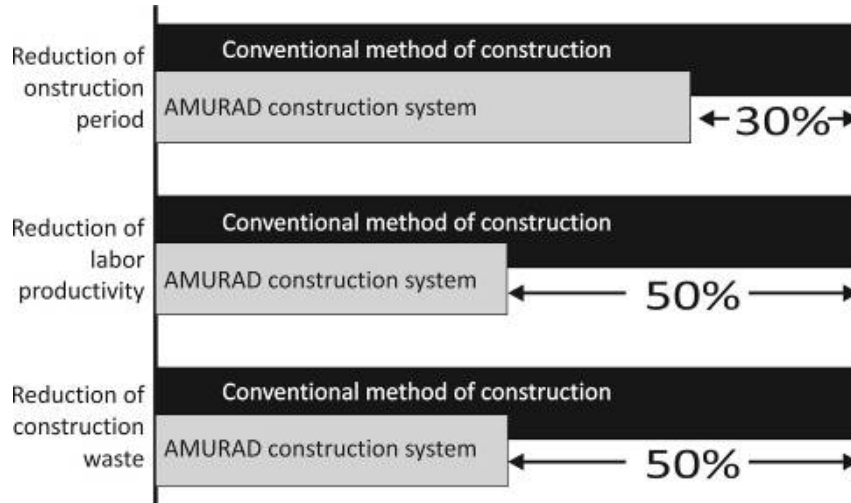

Figure 5-23: Construction work production rate comparisons (Kajima, 2000)

L

Learning Effects: Kajima measured the time needed for the installation of components in a building with nine floors over eight cycles. In general, the time needed could be reduced (learning effect) in all installation tasks by 40-50%. For example:

- Installation of precast concrete columns by Z-Carry: reduction from 20 minutes to 13 minutes.
- Installation of precast concrete girders by Z-Carry: reduction from 20 minutes to 9 minutes.
- Installation of precast concrete floor slabs by Z-Carry: reduction from 11 minutes to 6 minutes.

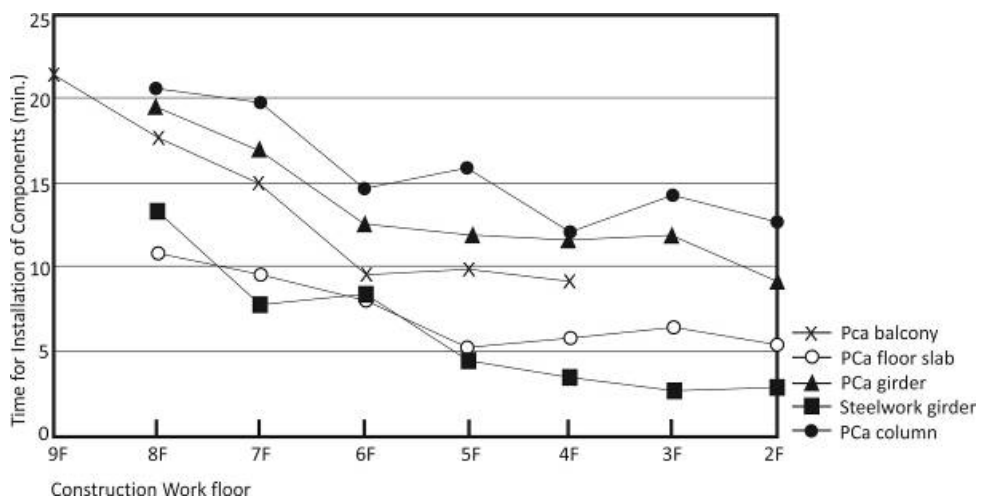

Figure 5-24: Time required for installation of various components (Sekiguchi et al., 1997)

Product Quality and Process Monitoring: AMURAD is based on an “information integration system” that helps to set up, control and supervise the construction process. The system allows the optimization and control of material flow, displaying the work progress status and control time and quality. The system is able to generate work schedules and operation instructions for equipment operators and workers.

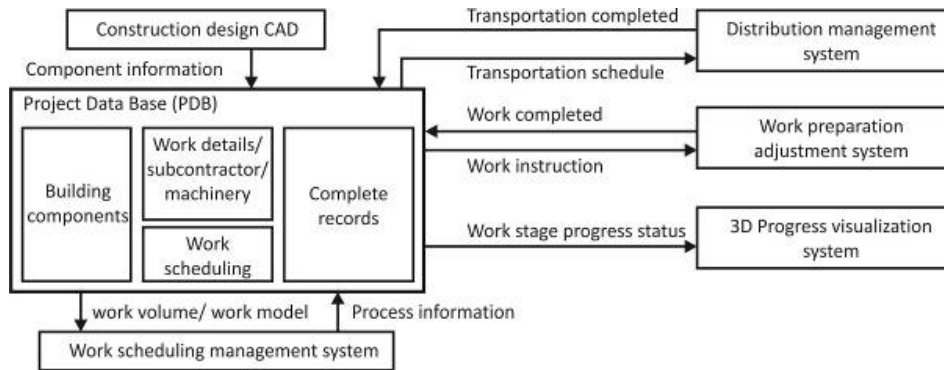

Figure 5-25: Overall view of information integration system (Sekiguchi et al., 1997)

SMART – Shimizu

Shimizu’s SMART erects steel based buildings. The factory on top of the building contains a system of gantry OMs which allow robotic trolley hoists to freely travel in the systems and thus to transport and position elements (columns, beams, floor slabs, facade elements).

Detailed Project Schedule: An analysis comparing conventional construction and SMART-based construction reveal that the SMART system reaches the breakeven point by about the tenth floor (Maeda & Miyatake, 1997; Maeda, 1994). The SMART is slower at the beginning due to the time required for construction planning, system programming and system set-up. For a 20 storey building the SMART is able to reduce the time necessary to construct the building by about 15%. If the building is higher than 20 storeys, higher gains in reducing the construction period are possible.

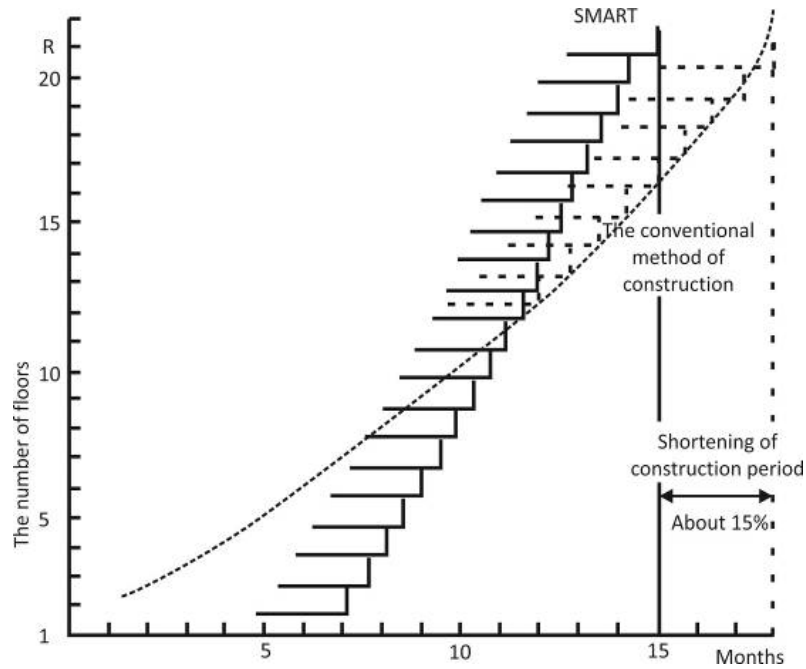

Figure 5-26: Shortening of construction period: comparison between conventional and SMART system of construction (Maeda & Miyatake, 1997; Maeda, 1994)

FES: Shimizu starts to operate the SMART on a seven day FES in the first projects, and has managed to reduce cycle time to five-and-a-half days after a certain number of projects and then down to five days after a further number of projects. The cycle time can be improved due to learning effects in operating the equipment (see also below *Learning Effects*).

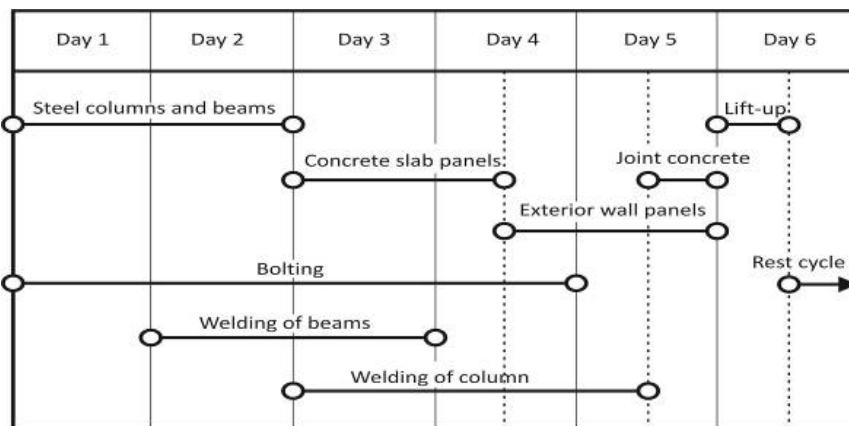

Figure 5-27: Five-and-a-half day FES process (Maeda & Miyatake, 1997; Maeda, 1994)

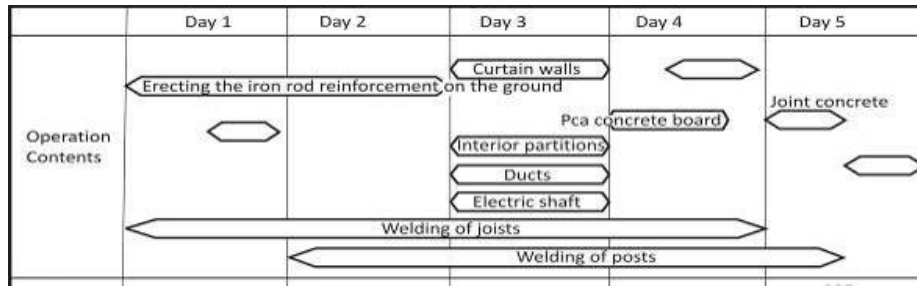

Figure 5-28: Five-day FES process (Maeda & Miyatake, 1997; Maeda, 1994)

Technical Data. Speed of Equipment: In a conventional tower crane based construction, components can only be delivered sequentially, one after another. The SMART, with its multiple robotic trolley hoists (up to 25), allows the parallel operation of multiple pick-up and positioning operations.

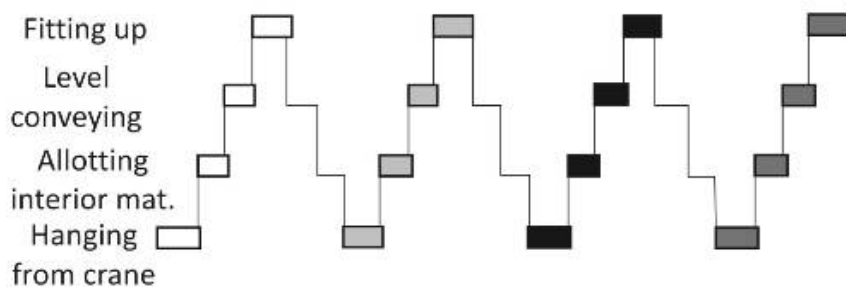

Figure 5-29: Conveying by conventional tower crane (Maeda & Miyatake, 1997; Maeda, 1994)

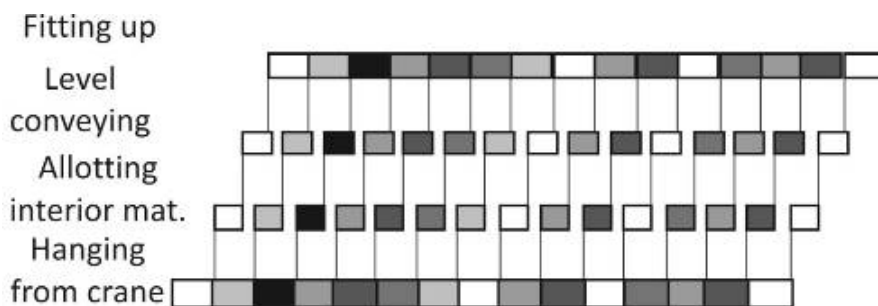
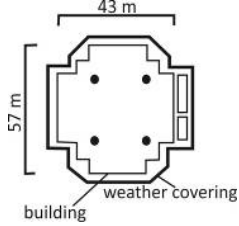
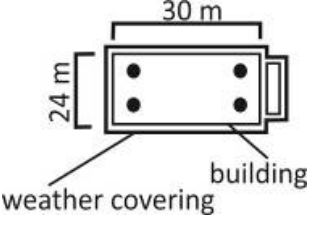

Figure 5-30: SMART conveying strategy (Maeda & Miyatake, 1997; Maeda, 1994)

Experiments with the Degree of Automation / System Configuration / Worker Teams: Similar to Obayashi's ABCS, or Big Canopy, the gantry OMs and trolleys can be operated manually or automatically. The most practical solution is for the gantry OMs and trolleys to operate automatically during transportation to the installation location and assembly, and positioning to be done manually. In various projects Shimizu experimented with different configurations of the site factory, and thus with different amounts and combinations of gantry OMs and trolley hoists. *Table 5-7* compares exemplarily two projects with substantially different configurations.

Table 5-7: Comparison of Yokohama project with Nagoya project (Maeda & Miyatake, 1997; Maeda, 1994)

	Rail city Yokohama building	Nagoya Juroku bank building
Total floor area	75,000 m	20,000 m
Standard floor area	2,100 m	750 m
Building height	132m	88m
Number of storeys (Above ground)	30 storeys	20 storeys
Shape of standard floor		
VDS	2 sets	1 sets
Overhead crane	24 sets	10 sets
Trolley hoist	10 sets	5 sets
Jacking tower	4 sets	4 sets
Hydraulic jack	150 ton X 12 sets	120 ton X 12 sets

Productivity: SMART enables improved labor productivity. The on-site productivity (measured in man hours) needed to complete the various working tasks in the first applications of SMART was increased by 50% compared to conventional construction

methods. The highest rate of improvement rate was to be found with the installation of the facade.

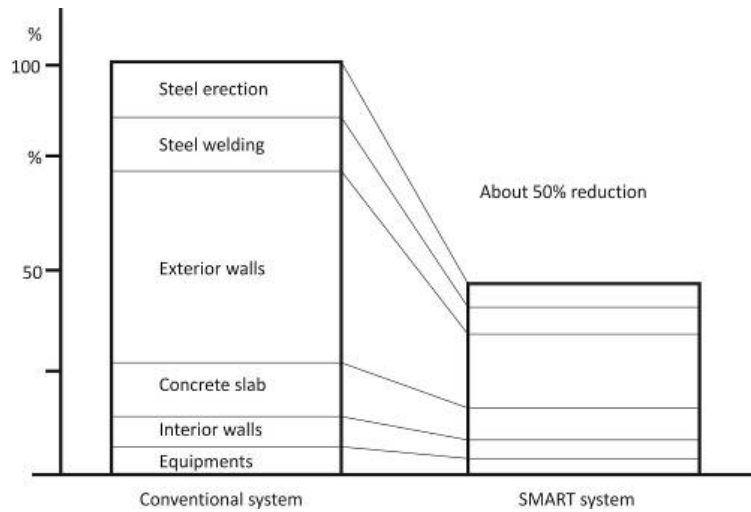

Figure 5-31: Reduction of man hours related to the construction of a standard floor manufactured by the system in full operation (Maeda & Miyatake, 1997; Maeda, 1994)

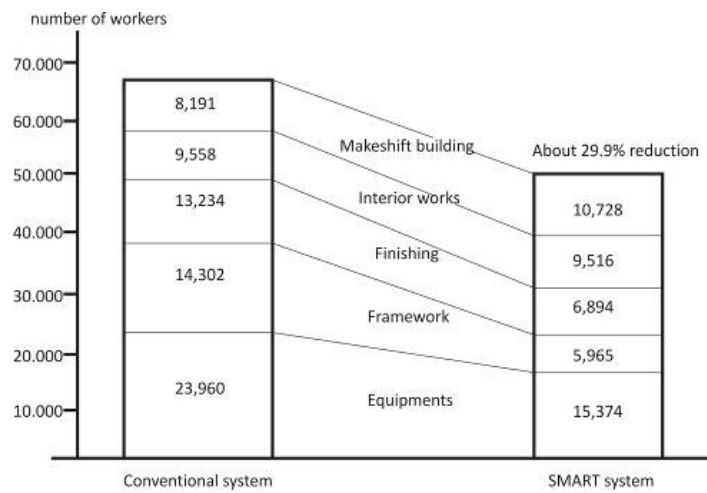

Figure 5-32: Reduction of man hours related to the whole on-site construction work, from ground level onwards (Maeda & Miyatake, 1997; Maeda, 1994)

Learning Effects: The table below (left) shows that, during the first projects completed by SMART, the time for the installation (logistics from storage on ground plus positioning) of

the bearing steel columns and beams was reduced from 42 minutes to 24 minutes (after 20 cycles). The most considerable reduction took place during the first two cycles. The table below (right) shows that (according to the reduction of installation time) the number of transport and positioning operations (installation operations) nearly doubled.

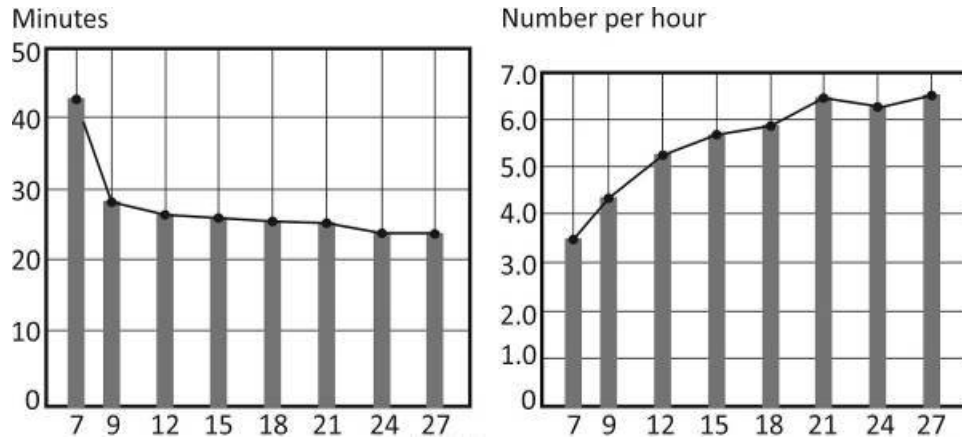

Figure 5-33: (left) Improvement of transportation and Installation time of members. (right) Improvement of the number of transportation (Maeda & Miyatake, 1997; Maeda, 1994)

Reduction of Construction Waste: SMART, in the first projects completed by it, reduced the amount of construction waste generated on-site by 70% due to the high prefabrication and the on-site material management system. A reduction of 70% is equivalent to a waste volume of about 700 tons. Construction waste still represents the biggest waste proportion compared to waste from manufacturing industries even in highly industrialized countries (see also 2.1).

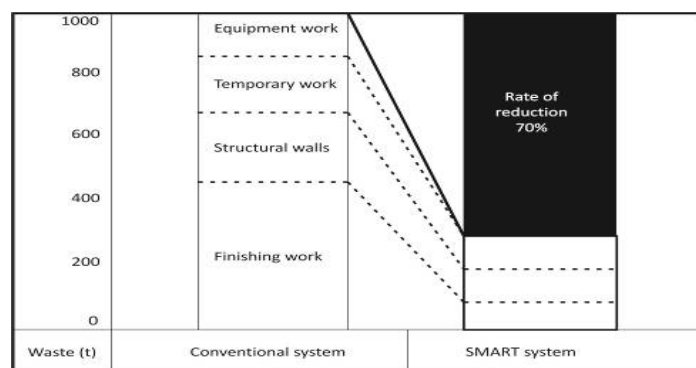

Figure 5-34: Reduction of construction waste (Maeda & Miyatake, 1997; Maeda, 1994)

Product Quality and Process Monitoring: Shimizu developed software for the SMART to generate and simulate transporting paths and positioning operations. Besides optimization of the transport and positioning operations, one aim of the system was to avoid collisions and thus damage to the building and building components. In addition to an assembly simulator, Shimizu developed a SMART-system disassembly simulator, which enables the simulation and optimization of the disassembly of the SMART on-site.

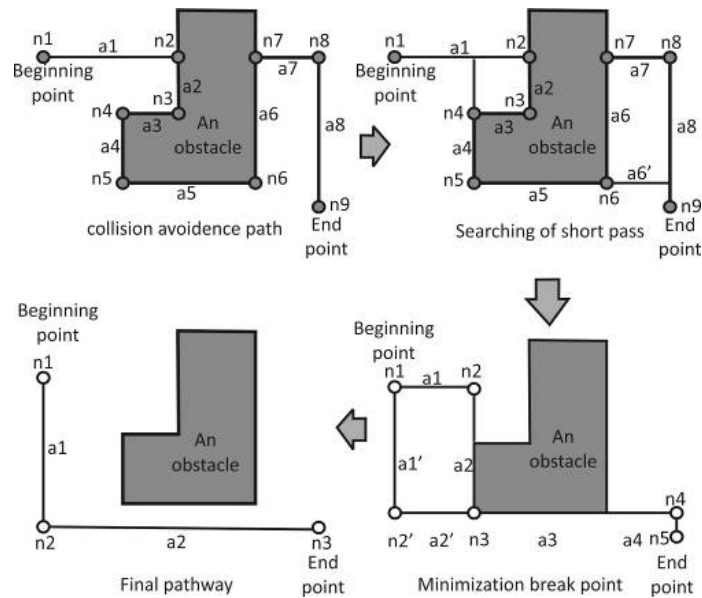

Figure 5-35: Generation of transportation paths and collision avoidance (Maeda & Miyatake, 1997; Maeda, 1994)

Safety: The SMART on-site factory on top of the building covers the workspace completely and protects it from:

- Wind
- Rain
- Sun (and therefore overheating in summer)
- Cold weather in winter

The workspace's climate is modified by a ventilation system. Artificial light further ensures appropriate working conditions and gives the possibility that the site potentially can be operated day and night. Furthermore, as the smart factory completely covers the building, finishes floor-by-floor and provides safe, covered working platforms, even for facade work, dangerous situations (e.g. falls) are completely avoided, improving the concentration of the worker on his work task, in addition to worker safety.

Roof Push-up – Takenaka

Takenaka’s Roof Push-up operates an SF on top of a building. In the SF, overhead manipulators assist with the installation of components. One specialty of the system is the full integration of a jib crane on top of the SF, which assists in delivering prefabricated plumbing elements. Another specialty is the use of a system that supports the installation of plumbing elements under the ceiling elements.

FES: Takenaka operates its system on a five-and-a-half day FES. Similar to other companies, Takenaka can complete a cycle working on several floors in parallel (construction floor, carrying floor and interior finishing in lower floors). The specialty of the system is the carrying floor.

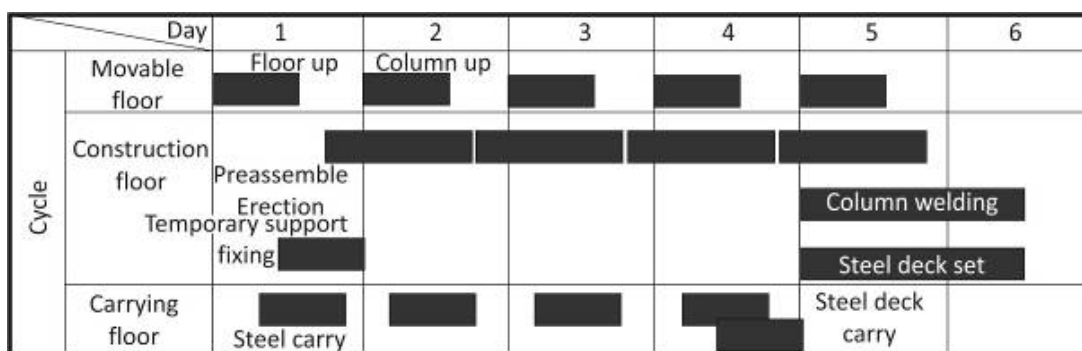

Figure 5-36: Overall work process chart (Morita et al., 1993; Fujii et al., 1995)

Experiments with Degree of Automation / System Configuration / Worker Teams: In order to optimize the sequence of component installation and the arrangement of labor, Takenaka started to develop a system to simulate the building assembly process, executed by the Roof Push-up system. The system was intended to generate the following parameters necessary to set up an optimized workflow for a given building configuration:

- Number of construction processes
- Number of workers/worker teams
- Number and location of temporary storage
- Sequence and interval of component pickup and installation

Figures show that the vision for that the system, starting from the general design, was that it would automatically generate the detailed design (optimized for Roof Push-up method in the sense of ROD), the construction planning/sequence generation, and on the basis of the generated data, would then enable construction management and monitoring. In the end, only the software module for construction planning / sequence generation was realized.

Table 5-8: Simulation for roof pushing construction chart to optimize performance cross all steps (graphical representation according to **Morita et al. 1993; Fujii et al., 1995**)

Step 1: Design	Step 2: Construction planning	Step 3: Construction management
Process planning	Realizing work design	Construction site monitoring
Planning the arrangement of labor	Best sequence of material instalment	Accuracy management Safety management
Planning the method of material carriage	Best arrangement of labor	Material management
Planning the arrangement of subsystems		Labor management

Using the realized construction planning simulation system, Takenaka, in the first projects using the Roof Push-up system, was able to determine, for example, the optimal number of workers or teams of workers (**Morita et al. 1993; Fujii et al., 1995**).

Productivity: The following figures relate the five-and-a-half day floor cycle execution scheme to the number of workers and types of workers needed per day:

- Day 1: 12 workers (CS jack operators, supervision workers)
- Day 2-4: 11 workers (steel workers, erectors, OM operators, precision operation workers)
- Day 5/6: 15 workers (steel deck workers, welding workers, steel workers, erectors, OM operators, precision operation workers)

Results: The horizontal precision of the movable floor push-up, the vertical precision of the movable column installation, and the floor jack were all maintained within the set ranges. The work unit ration based on the number of construction process was 0.25 men/m². This is very close to the average figure of the steel frame structure construction method. This result can be represented in a FES. It takes six days to complete a floor with the work unit ratio of 0.17 men/m² in a standard project (**Morita et al., 1993; Fujii et al., 1995**). There is, therefore, room for improvement with the overall productivity.

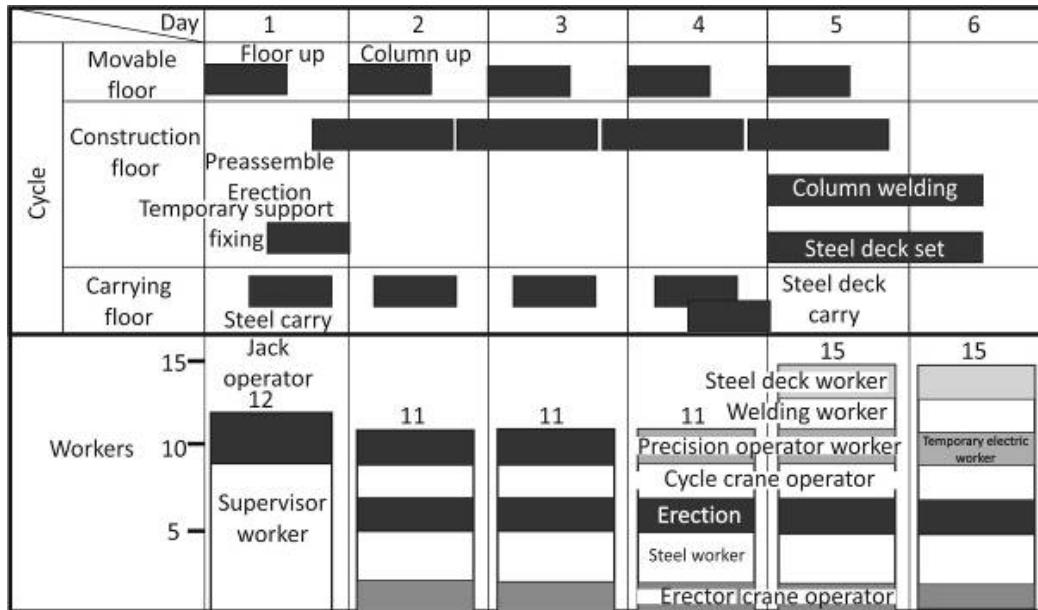

Figure 5-37: Overall work process chart (Morita et al., 1993; Fujii et al., 1995)

Product Quality and Process Monitoring: Takenaka supervises the construction progress in real time from a set of computers. It monitors working operations through video cameras and collects data about the precise installation of the components by a set of sensors installed in the Roof Push-up factory. The continuous monitoring allows Takenaka to simplify the quality assurance as well as to collect data about improvement of work processes and work productivity.

Central Control System: Operations in the Roof Push-up method are controlled by an RTMMS operated from a central control room on-site. The system consists of three subsystems. The operation monitor subsystem monitors work-in-progress throughout the whole construction site. The data from this system is used to inform workers about the progress of construction and their individual work tasks. The communication subsystem is used to give direct instructions to workers working on the movable floor or floor below. The precision monitor subsystem can provide a real-time monitor on floor and column installation.

Sequence of the Roof Push-up Method: First of all, the Roof Push-up method uses its overhead circular gantry OM system to lift up movable posts, beams and other materials to the uppermost floor. After the materials for the roof portico have been assembled, the push-up equipment is uninstalled. Facing materials for weatherproofing are then installed.

Akatuki 21 – Fujita

Akatuki 21 was developed by Fujita for the construction/assembly of steel based buildings on the construction site. Unlike many other systems, Akatuki 21 consists of a ground factory (material delivery, preparation, warehousing and logistics, joining of lower level parts/components to elements) and a factory on top of the building (with automatic/robotic OMs for element installation). Through the deployment of a ground factory that joins parts to elements, Akatuki 21 is more efficient than other systems in terms of the logistics from the factory/suppliers to the site, as parts in general can be packed more compactly, requiring fewer delivery operations.

Rough Project Schedule: To set up Akatuki 21, Fujita firstly installs the sky factory (SF) and the ground factory (GF) on-site, which takes about one to two months. The installation process takes a little longer compared to other systems, as the SF also represents the two uppermost floors of the building. These two floors are completely finished including facade finishing and serve the as the “roof” of the SF to which the equipment (OMs including hoist/end-effectors and guiding rail system) is fixed for the duration of construction. The SF then starts operating from the second floor onwards and assembles all following floors (except the two uppermost floors, which have been already finished on the ground), which are pushed up by the climbing mechanism. In full operation, Akatuki 21 can construct around three floors per month, so around four months are needed to construct, for example, 11 floors for a building with 15 floors. The two ground floors and the two upper most floors are built conventionally). The disassembly of the equipment of the SF and the GF requires one month.

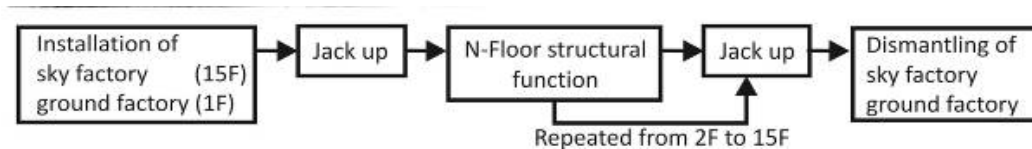

Figure 5-38: Basic construction procedure (Council for Construction Robot Research, 1999)

FES: Akatuki 21 operates with a FES time of eight days. Day 1 is used to install the steel columns one-by-one (using a special gripper for steel column erection). Over days 2 to 3, the main steel beams are installed (using a special gripper for beam installation). The sub-beams are installed on day 4, and the precast concrete floor elements are placed on days 5 to 6 (using a special gripper for floor element installation). Concrete is poured and leveled on-site on day 7 (using a special gripper for concreting), and finally on day 8 the SF is lifted and prepared for the construction of the next floor. For the erection of each floor, four different types of end-effectors are used.

Product Quality and Process Monitoring: Fujita uses a control room equipped with more than 20 monitors to supervise work tasks and the operation of the equipment of Akatuki 21.

The progress of the construction and the quality of the constructed floors is also monitored. The control room requires between one and two supervisors.

MCCS – Maeda

Maeda’s MCCS constructs steel based buildings by way of a factory that operates on top of the building. Main elements of the system are two gantry-like automatic/robotic OMs that are fixed to the roof of the SF, as well as to the automatic CS. The OM system is lighter than, for example, the OM system of FACES and thus also allows for faster operation. The two OMs can, through an opening in the factory on the side, pick up elements and install them directly.

FES: Maeda operates its MCCS on a nine day FES. Part of FES involves parallel work on three levels.

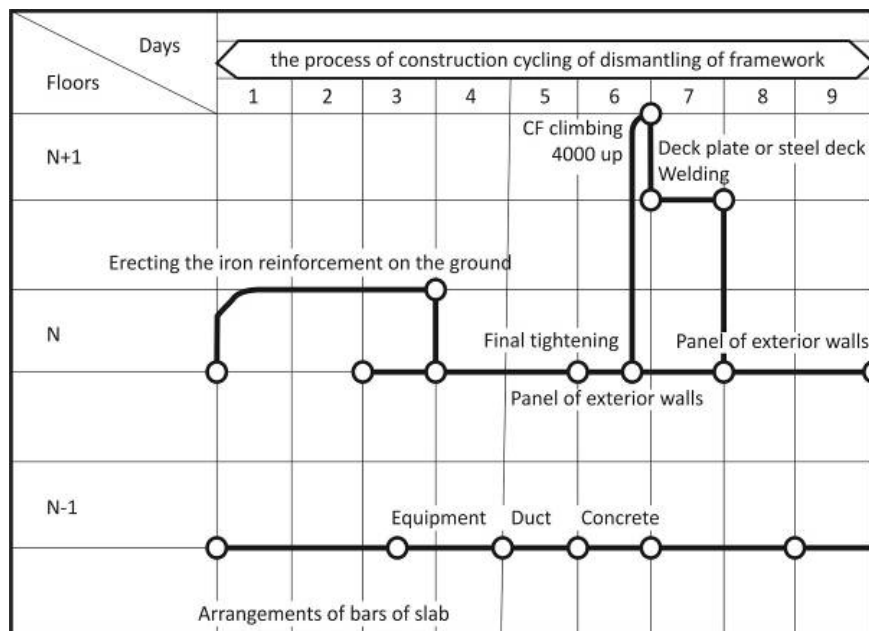

Figure 5-39: FES (Itou et al., 1994)

Technical Data Speed of Equipment: The CS and the overhead OMs are central to the system. The lifting of the whole factory to the next level can be accomplished by the CS at a speed of 0.37 meters/minute and the lifting of the SF’s stilts (necessary to the placement of a new steel column under each stilt) at a speed of 2.45 meters/minute). The OM system and its individual components can be operated at a speed of 20-25 meters/minute.

Productivity:

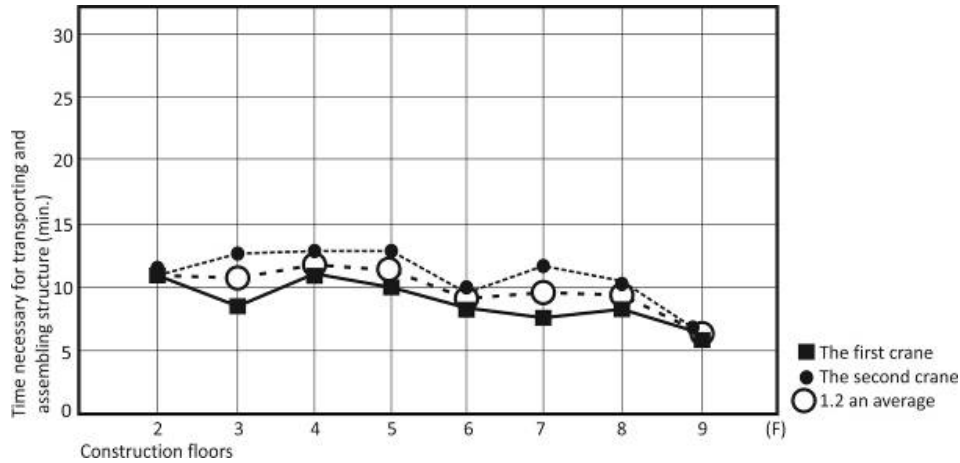

Figure 5-40: Time necessary for transporting and assembling structure (min./floor) (Itou et al., 2000)

Table 5-9: Construction Capacity (Itou et al., 1994)

Capacity Type	Capacity
The capacity of work on rainy days	100%
Reduction of materials used in temporary scaffolding by	65%
Assembly of the iron structure	3.65 tons/man
Welding (semi-automatic, by robot)	87.8 m/man/day, 59.8 m/robot/day
Attachment of precast concrete on the floor	36.8 m/man/day
Attachment of PC concrete on the external walls	15.0 m/man/day

T-Up – Taisei

Detailed Project Schedule: During one of the first projects completed by the use of the T-Up, Taisei conducted a detailed analysis of the performance of the system. The set-up of the core production structure takes about one month and the set-up of the structure for producing the core’s periphery another one-and-a-half months. However, parallel to the set-up of the core’s periphery production system, the core production structure can already be operated and can start to produce the first floors. The production of standard floors by the core’s periphery production system starts after the second floor. The system is able to

produce 28 floors in six-and-a-half months (without utilities and finishing work). The finishing of the floors takes another four months, and thus the completion of all 30 floors above ground floors takes 12.5 months in total, equal to 2.4 floors/month.

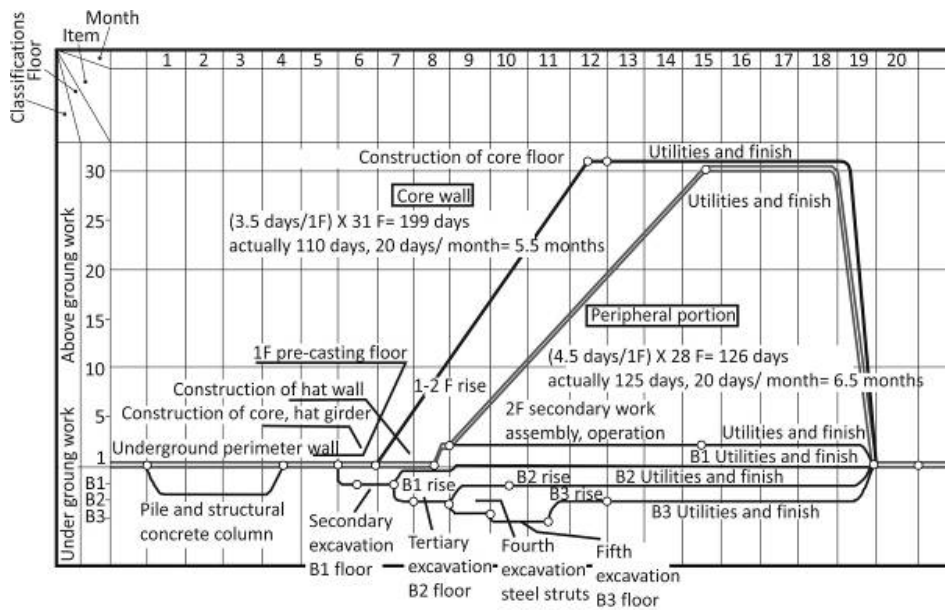

Figure 5-41: Construction schedule for model building (Sakamoto & Kumano, 1991)

FES:

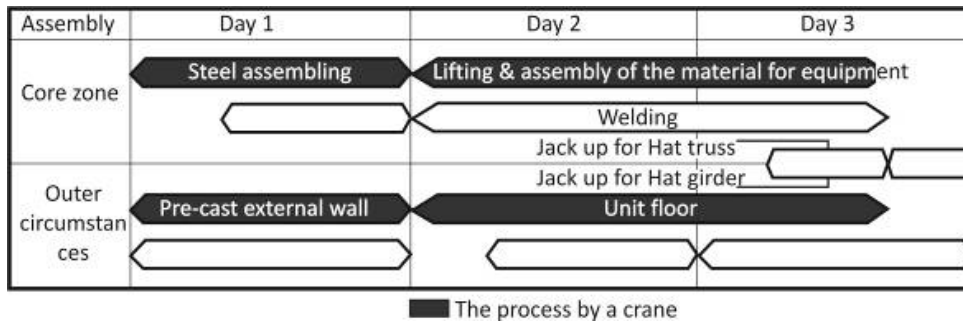

Figure 5-42: Construction process by a OM (Sakamoto & Kumano, 1991)

Poductivity:

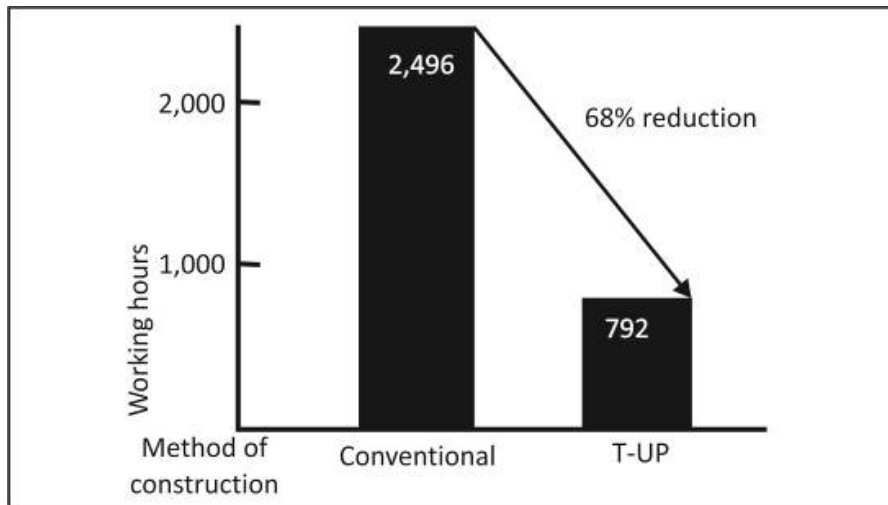

Figure 5-43: Labor productivity (Sakamoto & Kumano, 1991)

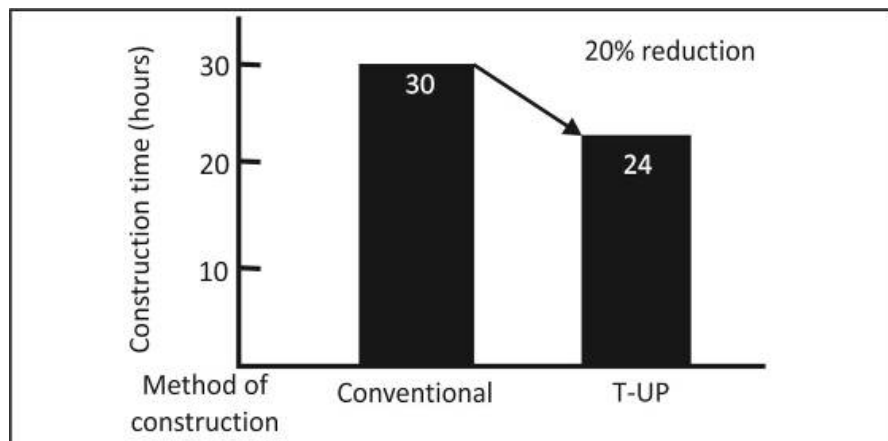

Figure 5-44: Construction time reduction (Sakamoto & Kumano, 1991)

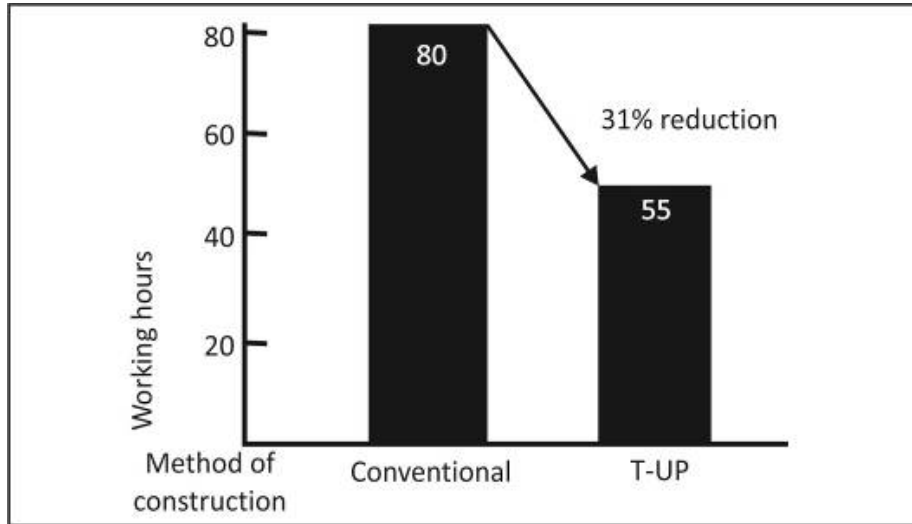

Figure 5-45: Reduction in time for removing the welding machines (Sakamoto & Kumano, 1991)

5.5 Conclusion: Discrepancy between technical Capability and Efficiency

The analyses of Automated/Robotic On-site Factories deployed so far reveal an interesting discrepancy between the technical state achieved and the improvements in productivity, economic performance and efficiency achieved. Whereas from a technical viewpoint the developed and deployed technologies (e.g. in terms of modularity, flexibility, variability, ROD) have reached an outstanding level, efficiency, productivity and economic performance stayed still behind the achievements in other comparable industries.

As part of the technical analysis, 30 different systems were analyzed systematically and based on the same framework according to parameters as main working direction, location of factory, evolution scheme, factory layout (vertical section/ground plan), subsystems, end-effectors, system variability and applied ROD (explained in detail in **6.2**). On the basis of the analysis, a categorization system was developed and 13 categories were set up (10 categories for construction and 3 categories for deconstruction, see **chapter 5**, and in particular **5.2** and **5.3**). Besides a technical description following the set-up analysis framework and laying down the analysis findings for each system, a graphical representation was generated depicting the system as a whole, the factory layouts and the most important subsystems. Furthermore, each system's manufacturing process and the real application of the systems on various sites was analyzed on basis of documentary material, videos and photos.

The conducted analyses claim to have identified and analyzed **all** approaches to Automated/Robotic On-site Factories that were conducted so far. Considering the analyzed systems, and the fact that some of the systems were used several times (for example ABCS and SMART each up to 10 times), that subsystem applications are frequently used (e.g. Obayashi), and that currently the application of the on-site factory approach for deconstruction is taking off in Japan, it can be said that the Automated/Robotic On-site Factory approach up to today was applied more than 60 times worldwide.

On the basis of the technical analysis, the categorization into 13 categories shows that Automated/Robotic On-site Factories can be installed at various locations on the construction site (on the ground, on top of buildings) and can progress in various directions (for example vertically upwards or horizontally) thus allowing solutions for almost any building typology (for example various high-rise building typologies, condominiums, point block buildings, steel buildings, concrete buildings, see **5.2.1** to **5.2.10**). Besides construction purposes, the on-site factory approach can also be used to deconstruct buildings of different typologies (see **5.3.1** to **5.3.3**). This means from a technical point of view, that Automated/Robotic On-site Factories, on the basis of the applied and analyzed technologies (subsystems, end-effectors, factory layouts), hold the potential to be developed for manufacturing any vertically or horizontally oriented building typology.

The systemic analysis of subsystems and end-effector technology showed that Automated/Robotic On-site Factories were in most cases developed as modular kits which allowed through a combination of in-built flexibility and modular flexibility for high variability. Each system could be broken down into multiple subsystems (see analysis of subsystems for each system in **5.2** and **5.3**). Systems that work besides a main factory (e.g. SF) with a sub-factory (ground-factory) are comprised of up to 12 subsystems. Simpler systems as e.g. the *Bauhelling* are comprised of only about 4 subsystems. On average, systems with only one main SF or GF are comprised of about eight subsystems. Subsystems that can be found in some form in any system are a type of factory cover, a climbing, sliding or push-up system and a vertical and/or HDSs. Concerning the end-effectors, two different major strategies can be identified (see analysis of end-effectors for each system in **5.2** and **5.3**). Either end-effectors are designed multipurpose with inbuilt flexibility or exchangeable-modular. In case of the modular approach up to 8 end-effectors could be identified for an individual system (ABCS).

Like advanced manufacturing environments in the general manufacturing industry, Automated/Robotic On-site Factories, generally speaking, were developed as sets of re-combinable subsystems with in-built (robotic) flexibility or with modular flexibility (e.g. end-effector change) that can be fully synchronized with the buildings modular structure through ROD. Likewise, the analysis of the variability and of applied ROD methods shows that on-site factories can be adapted within a certain extent (e.g. within a typology for which they are developed, see analysis of variability and application of ROD for each system in **5.2** and **5.3**) to various building projects and thus used to automate the subsequent construction of differently designed and shaped buildings. Although organizationally this capability was not yet fully used, technically speaking the analysis showed that the capability is embedded in the modular approach most systems followed.

The analysis of the evolution scheme, section ground plan and the manufacturing process showed that the factory layouts and the optimization of the material flow from material delivery to the site to the installation in a JIT and JIS like manner were a recurring theme see analysis of factory layout and manufacturing process for each system in **5.2** and **5.3**) Although some systems worked with temporary on-site warehouse modules or ground-based component processing yards (for example Akatuki 21, AMURAD, T-Up) a major focus was on optimizing factory layouts in order to erase the necessity of storage and allow a direct pick-up link between pick-up from delivery truck and assembly operations (for example Roof-Robo, BAM, System Skanska) and if possible even parallelized pick-up-assembly operations (for example SMART). As stated earlier, the factory approach and the networking of subsystems in order to create a continuous material flow on-site in a SE were a direct result of the negative evaluation of the approaches to STCRs in the 1990s. It can be said that Automated/Robotic On-site Factories, although they are not yet efficient enough, have definitely overcome the stand alone technology phase and showed that the setting up of flow-line-like or production-line-like SEs on-site is possible from a technical point of view.

The analysis of productivity, efficiency and economic performance of Automated/Robotic On-site Factories deployed to the present day (see **5.4**) have shown that improvements

were most obvious in the categories of erection speed, work productivity and resource efficiency. Considering the fact, that in conventional construction a maximum of two floors can be erected in a week (not including the installation of the facade, facade sealing, installation of floor elements and basic interior finishing, as in case of the integrated automated sites) the erection speed for standard floors increased twofold to fourfold. Work productivity and resource efficiency were improved each by more than the twofold. Furthermore, automated sites were able to reduce the amount of construction defects, safety risks, injuries and unhealthy physical strain to near zero. The efficiency analysis showed that integrated automated construction sites – nevertheless all systems were subject to experimentation and development and did not yet fully exploit the inbuilt potential – are able to achieve in all analyzed categories efficiency improvements that exceed the maximum performance possible by conventional construction methods and also those achievable by STCRs. However, compared to productivity and efficiency improvements that accompanied the introduction of advanced manufacturing technology in other industries and accounting for a much more radical performance improvement (e.g. automotive industry or TBM tunnelling, for detailed analysis and outline, see 3.3, and 3.4 in particular), the improvements accomplished by Automated/Robotic On-site Factories so far can still be considered as marginal. The findings of the efficiency analysis -including cross references to the technical analysis- can be summarized as follows:

- **Erection Speed:** Prior to the set-up, on-site integrated automated site systems require – in contrast to conventional sites – a planning phase (3-6 month) where the configuration of the factory and the equipment is planned and where the factory and the building kit are (e.g. according to ROD principles) adjusted to each other. The installation of the on-site site factory usually takes around one month. The first set up (e.g. FACES) can take longer (2-4 months) due to certification procedures and necessary test runs. The deconstruction of the site factory usually also accounts for one month. The floor production rate per month (standard floor) is between a minimum of two floors (e.g. AMURAD) and more than six floors per month (ABCS, SMART with learning effect). The floor production includes the installation of the facade, facade sealing, installation of floor elements and basic interior finishing. The floor production rate is, apart from the speed of the systems, dependent on the size of the standard floors. Most companies worked with an initial FEC of 6 days. Some companies (e.g. Obayashi, Shimizu) also experimented shorter cycles (3 days and less) after the execution of several projects. An FEC usually covered parallel work on multiple floors or levels (up to four floors/levels). In general, it can be said that systems that erected steel based buildings showed a higher erection speed than systems erecting concrete based buildings. On high-rise construction sites that use conventional construction methods, the construction of two floors per week (not including the installation of the facade, facade sealing, installation of floor elements and basic interior finishing as in case of the integrated automated sites) can be considered as fast.
- **Configuration & Adaptability:** Companies operated equipment (OMs, HDS, VDS) used for the installation of elements (columns, beams, floor slabs, facade elements) at speeds ranging from 10 to more than 40 meters/minute. Companies such as Shimizu and

Obayashi that worked with a multitude of smaller OMs or travelling hoists were able to operate their equipment faster (40 meter/minute) than companies that focused on larger and more powerful cranes (with higher accuracy/repeatability), such as Maeda and Goyo (20 meters/per minute). The lowest operational speed used the positioning robots of Kajima (10 meters/minute), which had to process heavy precast concrete components. Besides the horizontally working positioning equipment, the vertical lifts supplying those systems play a crucial role in creating a continuous material flow. In larger projects, companies often used several lifts in parallel (e.g. Obayashi). Companies experimented with different automation ratios. The positioning of components such as columns could be done automatically, half automatic (e.g. automation of positioning operation to near the installation location followed by manual final positioning) and manually via remote control. On the one hand, due to the processing of sensor and positioning data, full automation turned out to be 5-20% slower than manual operation. On the other hand, full automation saved supervising personnel.

- Companies also adapted the configuration of the systems from project to project to the individual specifications of the building. Therefore the allocation of e.g. OM systems, VDS, HDS, trolley hoists and lifts as well as their number was varied, forming variations of the factory layouts of the SFs and GFs. In general it can be said that companies such as Shimizu that used a fine grained OM system with smaller modules had more possibilities to adjust and reconfigure their systems to be used in a new project than companies that used large and powerful systems, such as e.g. Goyo. Experiments with the number of workers on-site showed that on automated sites the optimum input/output ratio according to the optimum principle is achieved with very low numbers of workers working at the same time on-site.
- **Productivity:** The reduction of human labor required on automated construction sites compared to conventional construction sites (comparable projects executed by the reference companies) was between 20% and 70%. The highest reduction of labor was achieved in the fields of facade installation (steel based buildings), concrete and steel bar/formwork work (concrete based buildings) and safety related temporary installations. Additionally, the workforce structure was considerably altered and shifted from simple crafts oriented work (reduction of workers in that field) more to work that needs multi-skilled workers capable of performing various tasks on-site, and supervisory workers capable of supervising and controlling the new equipment. Automated construction sites require about 11-15 workers constantly on-site, which equals the number of workers on-site when operating a tunnel boring machine. Furthermore, learning effects on automated construction sites (e.g. time necessary for installation of components with equipment, welding, etc.) were enormous and accounted for up to 50% within one project. So, for example, the installation of a reinforced concrete column by AMURAD was reduced from about 20 to 10 minutes and the installation of a steel column by SMART from 40 to 20 minutes. However, during the deployment of their first sites, Shimizu and Obayashi had the intention of training the workforce in general in the use of the new technology (according to Japanese philosophy, knowledge about new technologies and tools has to be spread quickly

among the work force by special training procedures) and thus exchanged half of the workforce from project to project with new workers, in order to train as many workers as fast as possible in using the new technology. This mitigated the learning effect cross projects considerably and it can be assumed that the above mentioned floor erection speed could be much higher when exploiting learning effects cross projects.

- **Resource Efficiency:** The positive impact of integrated, automated construction sites was mentioned by almost all companies. However, only one company (Shimizu) made a detailed and valid evaluation. It found out that automated sites reduce the amount of construction waste generated on-site by 70% due to the high prefabrication and the on-site material management system. This is equal to a reduction of waste volume by about 700 tons. Of course, waste was also generated in prefabrication factories, however, controlled environments and material flows generally make it much easier to recycle or reuse waste. The companies Sekisui Heim and Toyota Home, for example, which prefabricate houses in large scale in Japan, operate certified zero-waste factories.
- **Quality, Health and Safety:** All companies used material management and site control systems which allowed them to monitor construction activity, construction quality and the progress of the construction in real-time. Also most companies developed simulators which allowed simulating and optimizing the set up or configuration of the system on-site and its operation. Shimizu even developed a system for simulating and optimizing the disassembly of the machine system on-site. Furthermore, companies analyzed – by simulations and by measurements - the impact of the factory environment on the working conditions (safety physical strain, light conditions, etc.). The working conditions not only enhance safety and health but also productivity and (as workers can then better concentrate on their work task) construction defect rate. The environment reduced the physical strain (e.g. measured by heart rate) considerably as well as the risk of falls during facade work or the dropping of material/injury during transport.
- **Usability:** Usability studies showed that generally the new factory-like environment was neither evaluated positively nor negatively by workers themselves. An overall positive evaluation by workers was mainly mitigated by the fact that the systemized work environment obviously reduced the room for unnecessary breaks and laid back working attitude, changed the habits of the construction workers and thus was not in all aspects evaluated positively. This phenomenon accompanies many new developments that involve technologies that are able to systemize, track or record people and processes. Parameters that are related to the improvement of the work flow were evaluated positively by the workers.

6 Towards Real-time and Building-integrated Automated Construction

The analysis of deployed Automated/Robotic On-site Factories to date, from both a technical and an efficiency viewpoint conducted in the previous chapter has revealed that the approach is feasible from a technical point of view, but that in terms of efficiency, the only improvements so far achieved that can be considered comparable to conventional and non-machine technology based construction, were marginal. In the view of the author, it's out of the question whether this technology can be used in construction or if this technology might be too expensive – it can be used in construction once productivity, efficiency and economic performance of this technology compared to conventional construction is improved significantly. Key to further improvement is the following of the set direction of integrating stand alone or STCR technology into structured on-site environments to networked machine systems, but to improve organization, integration and material flow more radically.

Based on the analysis conducted in **chapters 3** and **4**, and particular in **chapter 5**, in the view of the author the question is not *if* the technology can be used but *how* it can be used and in particular *how* individual subsystems can be arranged and integrated into real on-site factories. In this chapter therefore an approach is presented which builds on the idea of automated /robotic on-site factories as analyzed in the previous chapter, but advances the idea and relates it to the idea of unit prefabrication (discussed in detail in **3.2**) in order to form a raw material transformation to on-site assembly continuous manufacturing chain. A system is proposed that would not only improve (e.g. as the above motioned management approach) or double productivity, but which would be able to multiply performance. Also, according to the hypothesis set out in **1.6** and discussed further in **3.4**, stating that an OEM-like integration structure, just as in other industries that assemble complex products in fixed-site/on-site factories, has to be combined and fully integrated with the on-site factory approach, the proposed approach will be used to further discuss this theme.

A technological system is proposed which is in tune with actual and future technological developments, and which has the ability to be continuously advanced in the future. In further chapters it is explained how this capital and technology intensive approach can be synchronized with the need for economic feasibility and the need for enhanced efficiency (see **7.1**). Furthermore, it will be explained why ROD can serve as a framework (see **6.2**) and how innovation methods can support efficient research, development and deployment (see **7.2** and **7.3**).

6.1 Achievement of a Novel Level of Productivity and Efficiency by the Consequent use of Technology

In **2.1** it was shown that productivity and efficiency in the conventional labor based construction industry in Germany, Japan and the USA has been declining for about two decades. In comparison, productivity and efficiency in most other industries (e.g. in the manufacturing industry) has constantly been on the rise during that time period. It was also explained that productivity alone cannot prove overall efficiency, but that it is definitely an indicator for efficiency, technological change and the possibility of cost savings. The decline of productivity since the 1990s has coincided with a worldwide re-orientation in construction from technological based construction towards labor based management and organization oriented approaches (for further details, see **2.1**). To date, major construction companies (Kessoudis & Lodewijks, **2012**) and many other practitioners and researchers have been seeking the solution for better productivity in construction, and even again increasingly in better management and organization of the conventional labor-intensive construction method (see **1.3** and also **2.1**). However, this approach sharply contradicts the logic and possibility of industrial and technological advances in manufacturing (outlined in **2.2, 2.3, 2.4**), and especially in countries with growing or high wages, capital-intensive methods outperform labor-intensive methods (**Paulson, 2004**; for further details, see **2.1**). This thesis developed an alternative approach to labor-based and labor-intensive construction. As outlined in detail in **2.1, 3.3** and **3.3.6**, the human factor as a means of production has “natural” limitations:

1. The human factor cannot be calculated 100% accurately
2. Human work is always subject to possible errors, delays and quality losses
3. Performance multiplication cannot be achieved by any amount by human labor (force and speed of the human work are basically limited, the speed and force of a machine is not limited and can potentially be increased to any amount)

In particular, in the analysis of the efficiency (presented in detail in **5.4**) it was shown that the current generation of automated construction sites is, on average, able to achieve improvements in terms of productivity and efficiency of about 50% compared to conventional labor-intensive construction methods. Relative to strategies that aim at better management and organization of the conventional labor-based construction industry, the gains in productivity and efficiency are enormous. Relative to other industries and the force multiplication, productivity and efficiency achieved in those industries (for further information, see **3.3** and in particular **3.3.6**), a 50% gain in productivity/efficiency is low. This is reflected further by the fact that the current generation of automated construction sites has not yet reached the level of economic feasibility (see **5.4** and **5.5**). The resources necessary to develop and deploy that system outperform the considerable but not yet high enough gains in productivity and efficiency. Nevertheless, the basis for the multiplication (not only marginal improvement) of productivity and efficiency can only be built by the consequent emphasises of technology and a maximized reduction of human labor on-site. Furthermore, technological systems – once modularized – can be seen as the basis for

continuous advancement and an enhanced speed of development of an industry (outlined in detail in 3.3.6).

6.1.1 General concept for target system

The general idea is the installation of a system on the construction site that allows a continuous and uninterrupted assembly of customized building blocks on the construction site to a (high-rise) building (*Figure 6-1*). The target system follows four main principles:

1. Uninterrupted and production-line-like material flow on-site
2. Maximum Reduction of on-site activities and activity complexity
3. Maximum Reduction of on-site construction time
4. Extensive use of modularity and self-adjusting/ fast connector technology

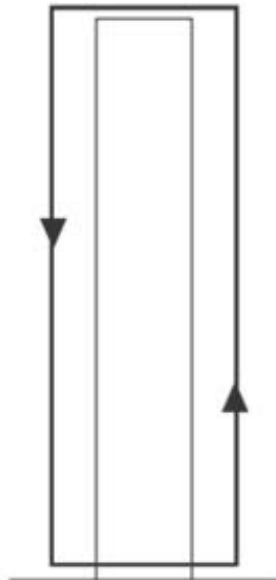

Figure 6-1: General concept for target system - uninterrupted and production-line-like material flow on-site, easement of any idle time/down time on-site

6.1.2 Uninterrupted and production-line-like material flow on-site

The subdivision into VDS (lift), HDSs and positioning systems on which most current automated construction systems rely, has to be overcome. The handover of components between those different systems is time consuming and complex and mitigates the positive effect of systematization and automation on efficiency relevant parameters, such as construction speed and work productivity. An interesting and extendable approach was provided by Shimizu's SMART, whereby individual (and in parallel) working automatic trolley

hoists picked up components on the ground (or directly from a truck) and installed them in a dedicated location without handover to another subsystem. Owing to the use of a strategy that builds on relatively small and thus relatively fast trolley hoists, SMART, with a subsystem travelling at speeds of 40 meters per minute compared to systems such as FACES and ABCS that relied on larger portal-based, gantry-type automatic OMs with high operational speed. However, the lifting of the automatic trolleys was problematic; it allowed one vertical lift to lift only one trolley hoist at once (thus in a variation with two lifts, two trolley hoists could be lifted at once). Considering the travelling speed of about 40 meter per minute and the fact that the lifting system also had to transport automatic trolley hoists back from the top factory to the ground, the continuous material flow was interrupted by the lifting mechanism for several minutes for each component installation operation. A system is thus needed that allows for multiple (e.g. more than 10 or 15) integrated building block pickup-transport-installation systems (e.g. automatic trolley hoists) to be lifted over transport channels in a chain (directly following each other) and in parallel. Continuous on-site material flow should be possible without interruption, 24/7. Automated tunnel boring machines (TBMs) which have strong similarities to automated construction systems (for further details, see **3.3.1** and **3.3.5**) are operated 24/7 in three shifts. Two shifts are concerned with tunnel manufacturing; one shift is concerned with the maintenance and repair of the TBM. However, TBMS are operated in an extremely harsh environment and are required to bore continuously for months or years. The target system, in contrast, should be robust enough to be operated without maintenance and repair shifts over a period of 5-10 days (intended net operational time) in a 24/7 mode. Here, the system of splitting up the installation system into a multitude of small and in parallel working trolley hoists is also advantageous, as those can be exchanged more or less instantly in the event of a defect by another fully functioning trolley hoist.

6.1.3 Maximum reduction of on-site activities and activity complexity

As shown in **4.1**, **4** and **0**, automation on the construction site demands a reduction of complexity on the construction site as a basis for the creation of an SE. Additionally, the analysis of integrated automated/robotic on-site factories (see **5.2** in particular), shows that all automated construction sites process on-site a high rate of high-level components instead of low-level component and parts, as is usual on conventional construction sites. The components positioned, adjusted and fixed by automatic subsystems, in particular, are high-level components. However, nearly all automated construction sites today have automated primarily the construction of the building's main structure (bearing structure including floor slabs etc.) and in some cases the installation of the facade. Although all other "non-automated" work activities are strictly timed, reduced in amount, significantly simplified and in most cases assisted (e.g. by working platforms for facade work, or material delivery systems, advanced equipment in form of STCRs), manual finishing work has not been reduced fully. However, even a highly reduced amount of manual work (up to 50%, see efficiency analysis in **5.4.2**) on automated construction sites represents a major problem:

1. **Incompatibility of high degree of automation and human work:** The mere presence of workers on-site impacts on the operational capability of the automatic system (due to safety reasons, operational speeds have to be reduced, and for manual adjusting of fixation processes, continuous operation has to be interrupted).
2. **Human work is not a 100% calculable means of production:** Even highly systemized, supervised and assisted manual work cannot guarantee 100% execution according to plan and schedule, and thus human work impacts negatively on time, quality and cost through possible deviations. As stated in **2.1**, human work is the only means of production that cannot be quantified and qualified 100%.

Industries with high efficiency therefore separate highly automated and high speed operating manufacturing processes, including accuracy and quality measurements (e.g. car body assembly in automotive) completely, or at least as far as possible from human intervention. At high altitudes in particular, as is usual in high rise construction, manual work is a risk for the manufacturing systems and for the workers themselves. The target system aims at maximal reduction of the complexity of machine activity, as well as manual work activity on the construction site by combining the approach of LSP (in particular unit based prefabrication as done by Sekisui Heim and Toyota Home; see **3.2**), with the approach of automated/robotic on-site factories. Unit based LSP reduces the amount of work to be done on-site down to about 15-20%, guarantees the highest quality, high resource productivity and recyclability of waste materials (both Toyota Home and Sekisui House operate so called zero-waste factories, see **3.2** and also **7.3.3**). The remaining 15-20% on-site work reduces the amount and complexity to a level which – according to the formerly outlined ROD principles – brings full automation on the construction site into the realm of possibility. A Sekisui Heim factory is capable of producing about 300 unit modules per day in peak times (e.g. Sekisui Heim, 1997).

35,000 houses x 15 units average / 250 working days x 7 factories = 300 Units/day

Assuming that a high-rise building has a standard floor area of 2500 m², a factory can produce about three floors per day. Sekisui Heim, as a company with seven factories, would thus in 1997 already have been capable of producing 21 floors per day for such a building.

2500 m² standard floor/ 25m² average size of unit = 100 units required per standard floor

Sekisui House which prefabricates equipped steel frames on a component level (40-60% work done in factory, see also **3.1** and **3.2**), produced around 80,000 buildings per year in the mid-nineties. Assuming that the sizes of the houses in terms of floor area were on average similar, this would mean that Sekisui House would have been able to produce about 45 floors per day. If automated on site construction systems could be operated faster than the above outlined output capabilities allow, companies would be likely to enhance their output capabilities even more. Furthermore, the advancement of manufacturing know-

how and technology since 1990 suggests that the above mentioned output capabilities can be enhanced. In order to be able to utilize the output capability of unit based LSP (e.g. Sekisui Heim, Toyota Home, Misawa Hybrid, etc.) and component based LSP (Sekisui House, Daiwa House, etc.) in parallel, it is intended that the target system should have a GF installed on-site. The GF has to be able to:

- Receive and prepare fully equipped large sized units that require no rework for lifting and installation
- Integrate several smaller sized units into large sized units
- Integrate units and components into large sized units
- Manufacture on a production line large sized units (which equal to very high-level components) out of components.

The installation of an on-site factory that allows the integration of components and small units to large units would reduce the necessary transport and logistics efforts from factories to the site considerably compared to a strategy which would build on full unit supply.

Sekisui Heim: 1-2 Units can be delivered per truck, 10 trucks per 15 units for standard house on average.

$$100 \text{ units standard floor} / 15 \text{ units per floor} \times 10 \text{ trucks} = 66.66 \text{ trucks/required per floor}$$

Sekisui House: 2-4 same-sized trucks required to deliver a house, this equals to a reduction down to 20-40% of the trucks required for unit transportation.

$$66.66 \text{ trucks/required per floor} \times 0,2 = 13,33 \text{ trucks required per floor}$$

6.1.4 Maximum reduction of on-site construction time

In order to be productive and efficient, time is an important parameter. Unfortunately in conventional construction, long on-site construction periods (high-rise construction roughly 2-4 years depending on size, condominium projects 1-2 years depending on size) are a fact, which is more or less accepted and has not been challenged substantially for decades. In contrast, the challenge in conventional construction currently is not how to shorten the construction period, but how to be able to keep (standard) construction periods in face of increasing technological complexity, and how to keep costs down (discussed in detail in **2.1**). Often, in order to be able to keep budgets, construction speed is lowered even further, as this allows construction companies to use their machine and human resources more freely, and thus to offer construction for a lower price. The analysis of the efficiency of automated construction sites showed that automated construction sites were capable of reducing the time needed for construction on-site by up to 50% (in particular, see **5.4** and **5.5**). However, in many cases, work productivity, resource productivity and quality of construction was improved, but the reduction of construction time was actually less than

50% or was nearly equal to the time necessary in conventional construction, including set-up times.

Considering the fact that the introduction of automated construction sites would be a major change of the structure of the industry and account for tremendous investment in R&D and machine technology (fixed cost), the benefits generated by site automation – especially in terms of time – must be a multiple of the benefit mentioned above. In most other industries that rely on a high rate of automation, the shift to automation over the in between steps of systematization and mechanization (see **3.3**, and in particular **3.3.6**) brought an improvement in terms of lead time, which accounted for a reduction of lead time by many times compared to the conventional crafts based method already in the systematization phase. Henry Ford, for example, reduced the lead time step-by-step from weeks down to days and finally down to 8 hours by systematization and mechanization. Today, modern automation technology allows producing a much more complex automotive product with lead times of several hours (e.g. recently less than 3.5 hours for the Smart produced in Hambach, see also **2.3**).

Compared to site automation, the Japanese LSP industry is pretty fast. Sekisui Heim and Toyota Home for example can, from the point of order onwards, deliver, assemble and hand over a house within a time frame of 2-2.5 months. This time frame includes production scheduling, production of units in the factory and on site assembly and finalization. The manual on-site assembly and finalization is especially time consuming. However, the lead time of the factory production of a unit is equal to the lead time of a car (2-6 hours depending on the complexity of the units; see **3.2**).

In order to achieve a continuous and line balanced off- and on-site combined building manufacturing process, it would thus be necessary to adjust the processing capacity and operational speed of the on-site (assembly) system as much as possible to the operational capacity and speed possible in components and units manufacturing in upstream manufacturing steps. According to the principles of manufacturing strategy and technology (presented in more detail in **2.3**) a timed, production-line-like, JIT and JIS total building manufacturing system integrating LSP and on site-construction could be set up. It is intended, therefore, that the target system will reduce the time necessary to construct a high-rise building down to roughly one-tenth of the time necessary to construct a building with the conventional crafts based construction method. The minimized construction time should bring following benefits:

1. Creation of high value built environment by fast availability
2. Fast compensation of high upfront cost
3. Minimization of disturbance of functional capability of surrounding city environment
4. Higher degree of capacity utilization of means of production

Creation of high value built environment by fast availability: A fast, or more or less “instant”, availability of buildings would minimize the risk of changing the value of a building product caused by significantly changing demand – a major risks for developers, investors

and customers. Globalization, novel technologies and a quickening pace of innovation, puts pressure, not only on classic manufacturing industries to react faster and more flexibly to changing demand, but also on the construction industry. Realization times of 2-5 years including the planning phase are not up-to-date in a globalized and networked world. Within such a long time frame, today, local economic, social and environmental circumstances and thus the value of the building for the customer can change dramatically. The closely related concepts of MC and RTE, as outlined in more detail the beginning of this thesis (**see 2.3**), are a modern and powerful reaction of the manufacturing industry to globalization, novel technologies and a quickening pace of innovation, implies, in addition to the delivery of highly customized or personalized products at reasonable prices, the production and delivery of them quickly and exactly when or for the point in time demanded (“real time”).

A product for a customer has the highest value at the time when the demand is actual and real. Even if the actual demand for the product lies in the future, it is an advantage to be able to produce it quickly, as this enhances the possibility to change and adapt the design (including value creating functions) of the product in real time prior to manufacturing, according to the actual future demand situation. In this thesis buildings are treated as advanced products and construction transformed to an advanced manufacturing process.

Fast compensation of high upfront cost: Buildings are products with enormous upfront costs. Upfront costs refer to expenses that have to be made prior to the setting-up up of a business or the start of the possibility of return on investment. Upfront costs for high-rise buildings are in the millions or even billions of Euros, and imply costs for development, planning and construction. The enormous upfront cost is, for investors, a high risk and means for developers an enormous amount of interest has to be paid to banks and investors. Long construction phases increase the risk, cost the developer a certain amount of interest per day or month, and delays the point at which repayment and return on investments can start. Shorter construction periods would minimize risk, lower interest rates, and lower the amount of interest payments, and lead to faster realization of repayment and return on investment. Depending on the equity ratio, it is highly likely that developers of larger construction high-rise projects pay several million Euros per month in interest. A reduction to the time necessary for construction to one-tenth of the usual time necessary would significantly lower the costs caused by interest payments from the viewpoint of the developer. The cost savings could be partly handed over to the customer, partly realized as return on investment and partly used to invest in automation technology, e.g. in the form of higher upfront cost.

Minimization of disturbance of functional capability of surrounding city environment: Larger construction projects disturb the immediate surroundings in the city, and reduce the functional capability, and thus the value of the environment, for the duration of the construction period. Blocked streets can use traffic irritations and traffic jams, and represent a safety risk. Construction noise disturbs tenants and employees and reduces work efficiency in nearby offices, shops and restaurants cannot fully utilize their capacity. Direct disturbances (e.g. in the form of blocked entrances or blocked visibility of nearby

offices, shops and restaurants) are often compensated in the form of lump-sum or non-lump-sum payments by developers and or/construction firms. However, a large amount of the reduction of functional capability of an urban environment by a larger construction project cannot be quantified or qualified and is also not covered by the legal framework.

A large amount of monetary and non-monetary costs caused by the disturbance is thus forcibly provided to the active society in the surrounding. Faster construction speeds can minimize the impact of disturbance and reduction of functional capability, and leads to a vaster enhancement of the value of the surrounding often achieved with the completion of larger and/or prestigious construction projects. As stated previously (see **2.1**), efficiency and performance can be viewed, measured and modified on different scales (ranging from work task/machine level, project/factory level, and firm level, up to greater economic level). Disturbances as outlined above reduce efficiency on a greater economic level. The reduction of construction times to one-tenth of the standard construction time would thus lead, assuming a number of such projects are conducted, to multiplication of the efficiency and functional capacity of whole urban environments or cities.

Higher degree of capacity utilization of means of production: As explained in **2.1**, in order to make the investment in novel site processes and technology feasible, it has to pay for itself as soon as possible, in terms of measurable earnings. Calculations of e.g. Kajima suggest that systems such as AMURAD or DARUMA pay for themselves after having been used eight times. Assuming that currently for each construction or deconstruction project those systems are blocked for more than one year (including the time necessary to adjust the system to the new project), an enormous amount of time is necessary to compensate for upfront costs for the system itself (cost for development, engineering and implementation).

Furthermore, it is not guaranteed that right after the end of one project, another project can begin that also requires the system. Thus, the risk of investment in advanced site-automation technology is, for construction companies outside Japan, practically impossible to bear. However, the situation would look completely different assuming that construction time could be reduced to one-tenth of the standard construction time. In this case the construction technology (and the related know-how embedded in engineers and workers performing the construction by applying it) would be available for new projects much faster, and two or even three projects per year utilizing the novel technology could probably be conducted. Additionally, between the projects, plenty of time for the adjustment of the automated construction system to the specifications of individual projects would be available, which would extend the scope of applicability (e.g. to new/another building typology) of the systems. A faster realization of gains would subsequently probably also lead to faster investment into improvement of the technology.

6.1.5 Consequent deployment of modularity, self-adjusting and fast connector technology

As explained in **chapter 3** in detail, the OEM-Model shifting (the creation of complex, high-level components to company internal and company external suppliers) is a pre-requirement for the application of automation and robot technology, as well as for minimized lead times in final assembly. A basic implementation for an OEM or OEM-like model is the split up of the final product into modules, which are clearly specified and in amounts minimized connections to each other and can thus be clearly allocated to a supply entity. In current construction practice, neither real modularity (see **2.2**) nor the applications of connectors that allow for simplified and fast connections are common practice (see **2.2**). As the analysis of automated/robotic on-site factories deployed so far has shown, highly efficient automated sites (in particular SMART and ABCS; see also analysis in **5.2.2**, **5.2.3** and **5.4.2** as well as summarisation in **5.5**) have modularized the building (and therefore partly changed designs of buildings and components) and used connections with compliance or plug and play capability wherever possible. Similarly, the Japanese LSP industry has modularized product structures and adapted them to the production line based manufacturing process (for further details, see **3.2.1**).

The introduction of a target system, as described in this chapter, would require going a step further regarding both modularization and in the creation of connector systems. The number of modules processed on-site would have to be reduced further, meanwhile complexity and the size of those modules would have to be enhanced. Furthermore, adjusting and fixation processes necessary during on-site assembly in the top factory would have to be reduced to a few minutes or to near zero for each module installation process by connectors in order to be able to utilize the high operational speeds of the automated positioning equipment. An example for an extreme type of modularization is the manufacturing of the SMART in Hambach (see **2.2** and **3.3.4**) where the final product is put together within a few hours by the assembly of a few fully functioning highly complex modules. The suppliers not only guarantee that the modules function 100% but in some cases also install them themselves on the assembly line in order to use their product knowledge and thus to speed up the assembly process further.

A schematic representation of the module-supply structure of conventional and automated construction strategies was introduced by Bock (**Bock, 1988**). Bock suggested an organization similar to the organizational form suggested for the target system (*Figure 6-3*). However, with the generally realized modular structure for the to-date developed and realized automated construction sites, the module-supply structure is rather the equivalent of the structure represented in *Figure 6-2*. Today's general module-supply structure in conventional construction is represented in an abstract way by *Figure 6-1*. The inconsequent application of a completely hierarchical and module count (on-site) reducing module-supply structure can be considered as a major reason why automated construction sites to date have been efficient but not efficient enough. The target system therefore suggests the consequent application of a module-supply structure as shown in *Figure 6-3*) – the processing of lower level components and parts has to be removed from the site.

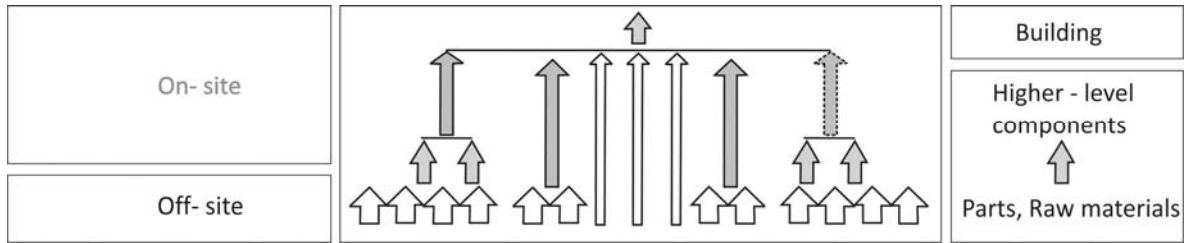

Figure 6-2: Today's general module-supply structure in conventional construction represented in an abstract way

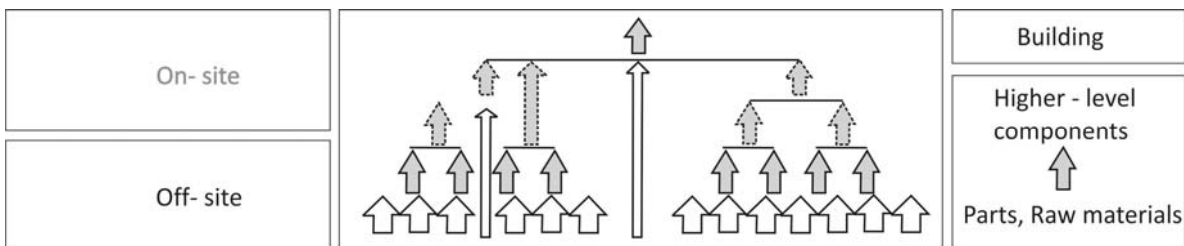

Figure 6-3: Module-supply structure of the developed and realized automated construction sites to date

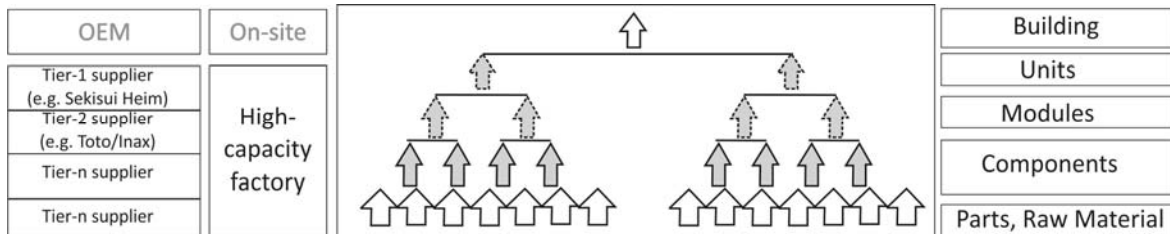

Figure 6-4: Ideal module-supply structure suggested for target system (based on Bock, 1988)

According to the OEM-like model, it can be suggested that the construction site has become a production-line-like, timed environment that processes incoming high-level components/units only, albeit at high speed. The on-site environment could thus simply become an extension of a high-capacity off-site located factory. In order to allow a pulsing site, according to downstream unit supply by a high-capacity factory, the module-supply structure of the building processed by the target system has to embrace the following principles:

1. **Modularity for OEM-like supply structure:** Subdivision of the final product into physically (and if possible functionally) clearly separable modules that support an OEM-Model, like the integration of lower level components to higher level components
2. **Synchronization of manufacturing system and modularity by modular coordination:** modular coordination system that synchronises manufacturing system and building modularity
3. **Maximum reduction of module count on-site:** Maximum reduction of the amount of modules that have to be handled during final assembly on-site (1st hierarchical level) in the top factory (and thus maximum size and complexity of modules)
4. **Module in-built adjustment technology:** Support of each adjustment process on-site by a compliant joint, so that both repositioning and the use of complex sensor systems (which would lower operational speed on-site) can be more or less completely avoided.
5. **Module inbuilt fixation technology:** The basis for compliant and self-adjusting joint technology can be provided by ROD (explained in detail later in **6.2**) and for immediate fixation by fast connector technology (see **2.2**). Furthermore, it can be suggested that currently common fixation technology (bolting, welding), which is time consuming even when automated, is similar to the automotive industry in terms of adhesive bonding technology.

The implementation of the above motioned principles would require an abandoning of the current practice of segregation of construction trades, or at least a restructuring of the interaction between those trades. Furthermore, both the restructuring of the modular structure in addition to the development of self-adjusting and fast connector technology suitable for on-site automation would require task adequate skills in the early design and planning phases. Thus, even prior to the introduction of automated on-site construction, both modular structuring and connector methodology have to have been made an integral part of architectural teaching and R&D in the field. The development of modular building systems and connector technology has already been the subject of several major research projects to which the author of this thesis has contributed (see **2.2**). However, in order to be able to set up the above mentioned ideal module-supply structure, research activity in this field has to be intensified and has to involve all construction related trades and planners. As a multitude of manufacturing industries have already developed solutions in the field, technology transfer to the construction industry (discussed later detail in **7.2** and in particular in **7.2.2**, **7.2.3** and **7.2.4**) could considerably reduce the time and cost necessary for the development of modular structure and connector technology.

6.1.6 Identification of novel elementary technology

The technology transfer from other industries could reduce complexity (time, cost) of development of the target system. The following related industrial areas can provide solutions for sub-problems and subsystems of the target system:

Automatic container handling technology: The new generation of container terminals, such as Hamburg's Container Terminal Altenwerder (CTA) are able to automate almost the whole process from picking up a container to positioning it on a truck or train. The new container cranes ("access points") with two trolley hoists (also called "crabs") are able to load/unload a container every two minutes. The two trolley hoists therefore operate in parallel with one picking up the container from the ship and placing it on an intermediate platform. From there on everything proceeds automatically and the second trolley hoist positions the containers automatically on AGVs, which then transport them automatically to also automated intermediate storage lanes, where automated and so called Double Rail Mounted Gantry Systems (DRMGs) process containers. Due to the high degree of automation, the new generation of container terminals can be operated 24/7. Assuming that a terminal can erect up to eight access points over, for example, Maersk's EEE container ship class, 18,000 containers can be loaded/unloaded within three full days:

18,000 TEU Containers x 2 Minutes / 60 minutes = 600 hours = 25 days

25 days / 8 (number of access points) = 3.13 days necessary to unload Maersk's EEE

In order to achieve a similar operational capability within the target system, the following concepts and technologies can be transferred:

- Double Rail Mounted Gantry Systems (DRMGs) for unloading units, modules or components automatically from trucks delivering material to the GF.
- AGV System for automated organization of material flow in GF
- Access Points and multiple crab system for automated positioning of the system in the top factory
- Compliant gripping mechanism for gripping containers can be transferred to gripping mechanism for units.
- Connector systems (corner castings, compliancy, connection with truck, train) and modular coordination can provide basic ideas for unit logistics systems

Observation wheel technology: Observation wheels are able to be operated without interruption by several hours. During operation, the passenger cabins are continuously kept in an upright position. Both the characteristic of continuous operation, as well as the characteristic of keeping the carrying elements in an upright position would be necessary to transport units continuously from GF to top factory. The new generation of observation wheels, such as the London Eye and the Singapore flyer use complex sliding mechanisms that allow the cabins (in order to stay in an upright position) to rotate freely in a frame positioning them on the outside of the wheel's steel frame. The following concepts and technologies can be transferred:

- Mechanism that allows continuous rotation of the wheel could be used to operate the lift system carrying the units continuously.
- Mechanisms that keep cabins in an upright position can be used to keep units in an upright position during transport and positioning operations.

Lift and detachable grip technology: Ski lifts with detachable grips are capable of being operated at speeds of about 300m/minute, meaning that a cabin during ascendancy is pulled upwards by a considerable speed. When entering ground stations or top stations for passengers entering or departure, the passenger cabins can be disconnected from the high speed operating system by a detachable security grip. The following concepts and technologies can be transferred:

- Rope pulling mechanism in order to achieve high speed (Compared to the operational speed of current lifting technology in automated construction sites – about 40/m per minute- lifts operate at high speed)
- Flexibility of connecting cabins from the high speed “pulling” system can be used to disconnect grippers for unit pick (GF) up and positioning (top factory)

Use of skill and knowledge of special-purpose machine builders: Companies building special purpose mining equipment such as bucket wheel excavation systems for coal mining, have the knowledge and skill in engineering and mining extremely large heavy machine systems. Those machines often integrate the excavation and on site material transport systems to largely automated combinations of machines. The following concepts and technologies can be transferred:

- Knowledge to engineers and the building of large and highly robust machine systems can be used to engineer and build a machine system that spans several hundred meters over the ground and top factory.
- Mechanisms for robust and continuous transfer of material

Self-adjusting and fast connector technology: As explained in **3.2.3**, and in particular in **6.2.10**, Sekisui Heim, for example, uses a compliant joining system to speed up the positioning and adjusting process of modules on-site. Furthermore most automatic construction sites use compliant and self-adjusting joints to simplify positioning and adjusting of columns and beams (see technical analysis in **5.2** and in particular **6.2.3**, **6.2.4**, and **6.2.6**). Companies such as FACES (see technical analysis in **5.2.1**) and Kajima (see technical analysis in **5.2.4**) even use a type of fixture into which elements are then positioned by the robots. Research contributed to by the author developed fast connector systems for connection walls, furniture and appliances in a plug-and-play-like mode. The following concepts and technologies can be transferred:

- Compliant self-adjusting joints for speeding up positioning and adjusting process in top factory (units, superstructure girders)
- Mechanisms for instant physical fixation of units and superstructure girders

Automated cellular warehouse technology: Upcoming automated order fulfilment and cellular warehouse technology, as represented by Kiva Systems’s automated warehouse technology, or Dematic’s multishuttle allows mobile robotic logistics system to travel freely horizontally and vertical in specially designed rack systems (see also **2.3**). Instead of transporting small component carriers, this technology could be adapted to the completely

automated transportation of units and girders horizontally and vertically on-site. The following concepts and technologies can be transferred:

- Combination of vertical and horizontal transportation system (multishuttle)
- Automatic logistics technology (localization, motion planning strategies, processing software)
- Component carrier pickup/handover technology (multishuttle)

6.1.7 Systemic development and discussion of approaches (Approach 1-4)

In order to further detail the target system according to the general concept, the requirements defined and the possibilities for technology transfer outlined for approaches were subsequently considered. Approach 1 is built up on the basis of standard steel or concrete based high rise typology with a core area in the middle. Approach 4 switches to a typology which emphasises a superstructure in order to achieve higher efficiency of the target system.

Approach 1: Two loop-like lifting and positioning systems span the building. Seen from atop, one operates in y-direction, one in x-direction. One system (blue) picks up components and units on the ground floor and operates on top of the other system. The other system (purple) picks up components on the second floor and operates under the previously mentioned system. This decoupling allows the two loops to work in parallel at high speed and for one loop to be able to be operated even during the time when the other one is being lifted. The loops are fixed to a building integrated rail system every ten floors, which allows them to slide, computer controlled, in x- or y- direction. The transport and positioning loops are lifted by a push-up mechanism similar to Fujita's steel frame push-up system "Arrow Up" (see 4.2.2 and Figure 4-5). In z-direction, a third robot system (orange), which is guided and held by the vertical loops, is able to work on the exterior of the building (positioning and adjusting of elements, sealing, painting, etc.).

Approach 2: This approach works similarly to Approach 1, with two unit and component transportation and positioning loops. In contrast to Approach 1, the two loops span the building in y-direction and are identical to each other. This removes the complex intersections, especially on the top floors, where units as well as control schemes and control systems are positioned. Pushing up of the loops is accomplished by an "Arrow Up"-like push-up system. In z-direction, a third robot system (orange), which is guided and held by the vertical loops, is able to work on the exterior of the building (positioning and adjusting of elements, sealing, painting, etc.).

Approach 3: Approach 3 builds fully on Approach 2 and adds a platform to the loops that completely spans the floor area of the building. The transport loops become static and only function as a transport loop. For horizontal transportation on top, positioning and adjusting, the unit carrying system decouples (e.g. through detachable grips, explained previously in this chapter in 6.1.6) and then move along a guiding system under the platform, on top of the loops. In z-direction, a third robot system (orange), which is guided and held by the

Analysis of alternative Approaches

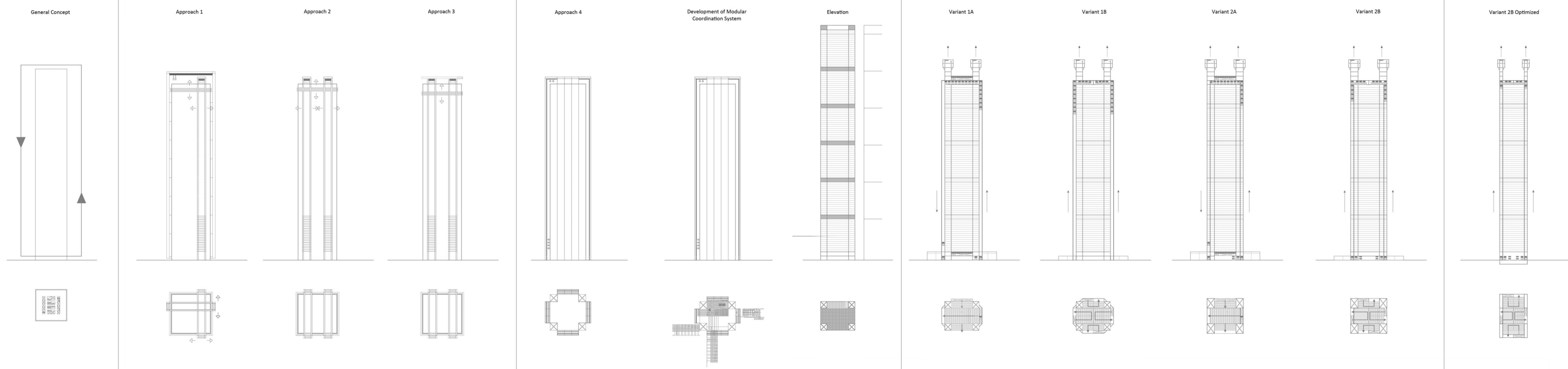

Approach 5 Variant 2B optimized - Analysis of Evolution Scheme

- Superstructure Tower Site Factory (STSF): Building up the four corner superstructure
- Ground Factory (GF): factory on ground where 3 BMU broad and maximum length units are prepared for pickup by crabs - GF is directly integrated with TLs
- Girder and Standard Floor Top Factory (GSSF): factory system on top - directly integrated with TLs
- Transportation Loops (TL): vertical transportation channels - integrated with GF and GSSF
- Crabs: Trolley Hoists picking up, transporting and positioning the units and superstructure girders

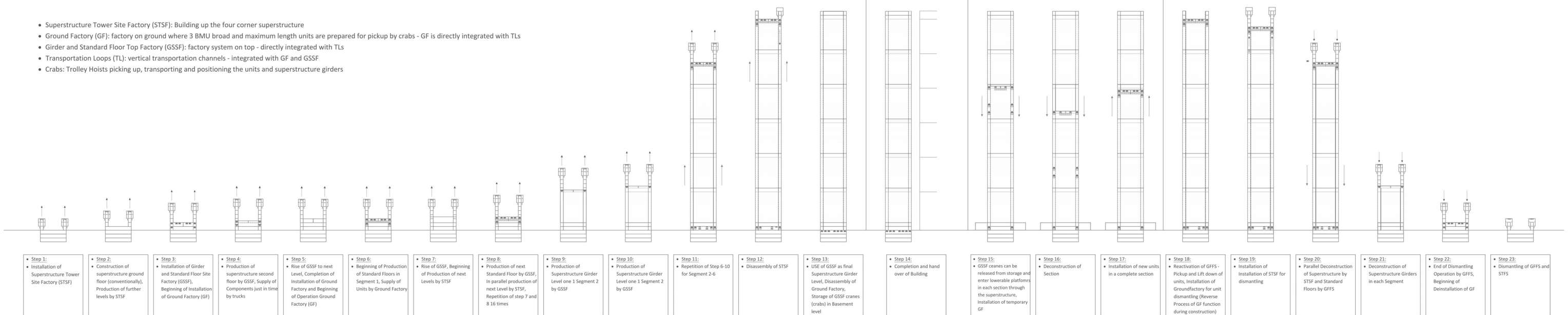

Approach 6

Visualization of Approach 5

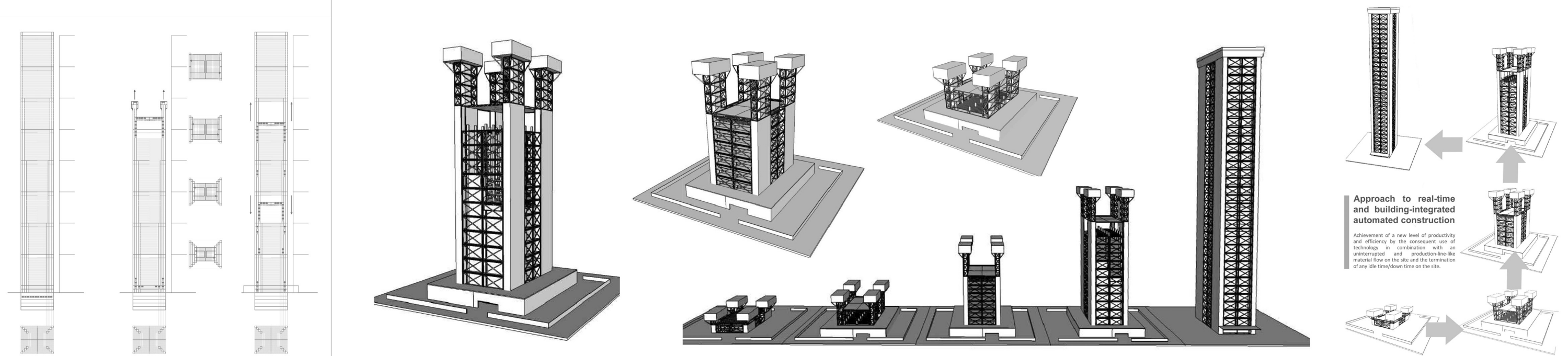

vertical loops, is able to work on the exterior of the building (positioning and adjusting of elements, sealing, painting, etc.).

Approach 4: Approach four combines elements of Approach 1, Approach 2 and Approach 3 but goes a step further: the two loops span the whole building, except the corners. The building typology is changed to a typology emphasising a superstructure in the corners. The rest of the building is completely enclosed by the transport and positioning loops. Each loop contains three fixed unit lifting lanes. As the two loops do not have to be repositioned continuously, six units can be lifted at once. Due to the loop approach, the lifting lanes are not blocked by unit carriers going from the top factory back to the ground. Thus sets of six parallel-uplifted unit-carrier-systems can be sent to the loops in very short intervals, or even in sequence. As with Approach 3, a platform on top allows distribution of the units. The building, as well as the two loops' lifting lanes, are based on the idea of using the maximum possible freight container standard size:

- Maximum possible freight container standard size: 1 FEU = 2 TEU
- FEU: Forty-foot Equivalent Unit; ISO standard container, 40-feet long
- TEU: Twenty-foot Equivalent Unit; ISO standard container, 20-feet long

2 TEU or 1 FEU = 29.7241 m²

Floor Area Total = 3716.1216 m²

Floor Area Central Area = 3121.5422 m² (210 TEU or 105 FEU)

Floor Area Superstructure = 4 x 154.7407 m²

The idea of a vertically (z-direction) moving robot system processing the facades has been abandoned in order to reduce the complexity of the target system. The units positioned on top of the building can be fully equipped with all exterior finishing in the GF or off site and connector technology should allow the abandoning of exterior rework (e.g. sealing) completely.

6.1.8 Relevance of the super-structure/sub-structure approach for target system

The idea of developing large “superstructures” (long life cycle), which host smaller sub-entities (offices, houses, flats, etc.) as a kind of “infill” (short life cycle) was already explored by Kenzo Tange (e.g. A-Frames) in the 1960s, and later by the Metabolistic Movement in Japan (**Yatsuka et al., 2011**). In his master thesis in 1953, under the supervision of Mies van der Rohe, Myron Goldsmith analyzed the effects of scale on tall buildings and explored the possibility of constructing those buildings on the basis of a clearly visible super-frame or superstructure that takes up a so called sub-structure (**Blaser, 1987**). Later, van der Rohe (together with a group of young engineers including Goldsmith) applied the idea of clearly visible superstructure (exoskeleton) to the S.R. Crown Hall of Chicago (**Cohen, 2007**). Goldsmith (structural engineer and Professor at IIT Chicago) and Kahn (architect and Professor at IIT Chicago) later on during their work at Skidmore Owings Merrill (SOM)

realized a multitude of buildings based on the idea of not only subdividing into superstructure and substructure, but making the super structure and thus the transmission of forces within the high-rise building a clearly visible architectural element. The idea of superstructure/substructure thus became a general element of architectural practice and of high-rise engineering and typology (**Grube et al., 1973; Murray, 1990; Grube & Krehl-von Mühlendahl, 1974; Curtin et al., 1983**). From 1979 to 1986, Norman Foster designed and engineered the Hongkong Shanghai Bank and further explored and spread the concept (**Stevenson, 1998**). Examples of high-rise buildings were successfully realized on the basis of superstructures:

- Alcoa Building, San Francisco, SOM
- John Hancock Center, Chicago, SOM
- Sears/ Willis Tower, Chicago, SOM
- Exchange House, London, SOM
- Hongkong Shanghai Bank, Shanghai, Norman Foster
- Commerzbank Tower, Frankfurt, Norman Foster
- Hypo Hochhaus, Munich, Beetz Architects
- BMW-Tower, Munich, Schwanzer

The concept of dividing a building into superstructure and substructure is an approach that introduces the concept of hierarchies to a building's structure and components, and can thus serve as the basis for possible modularization. Hierarchical modular structures are an important element for the introduction of integrated automated construction sites and the related OEM-like organization (see **3.2, 3.2.4** and **3.3**), as they allow subsystems to be manufactured by different entities off-site and then put them together on site. Furthermore, modular hierarchical structures can be used to apply parallel processing in engineering, OFM and also on-site. The concept of clear subdivision into superstructures and substructures is also related to the concept of modularity and F&I strategies (explained previously in **2.2**) and the use of plug-and-play connectors/fast connectors that allow the exchange of substructure during the life cycle of the building (explained previously in **2.2**).

The possibility of using modular hierarchical structures to build changeable architectural structures was in reality not often realized (except e.g. Osaka Next 21, by Prof. Uchida), the idea has been part of architectural discourse and research for several decades. Integrated automated site technology, as described and proposed in this chapter could fully utilize the modular hierarchical approach of the concept of superstructures and sub-structures. Additionally, integrated automated site technology that becomes part of the building (as described in detail later in this chapter) would provide a building integrated tool or machine for the difficult exchange of complex and larger sub-structure elements (especially at higher altitudes. Site automation technology could thus become an enabler of a state-of-the-art architectural concept, long envisioned but as yet not realized on a large scale.

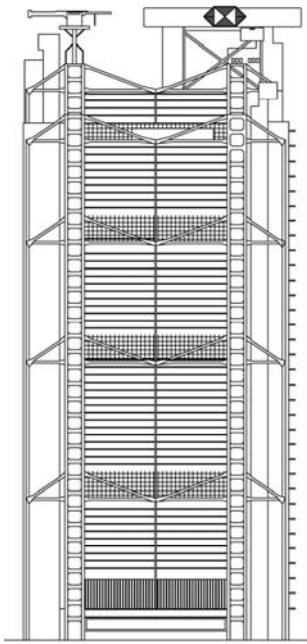

Hongkong Shanghai Bank, Norman Foster

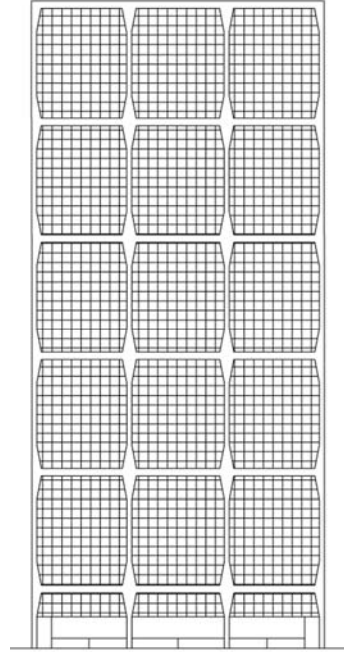

Master thesis, Goldsmith, M.

Figure 6-5: Examples of buildings with superstructures

6.1.9 Through modular coordination to Approach 5

Approach 4 revealed that both the dimensions and the structure of the building, and the dimensions and structure of the transportation and positioning loops have to be fully coordinated with the dimensions of the units to be processed. Modular coordination has to cover x-, y- and z-axis. Two state of the art modular coordination systems have been analyzed:

System 1: Modular coordination current freight container systems

To guarantee compatibility and stackability, the freight container system integrates a system of corner fittings on the basis of a modular coordination system. Those corner fittings allow stackability as well as picking up and positioning e.g. by “crabs”. The container measurement system is laid down in ISO 668 and the specifications relating to the corner fitting can be found in ISO 1161.

Length Standards:

45 Feet = 13.716 m

48 Feet = 14.630 m

53 Feet = 16.154 m

A = 12.192 m (Forty Feet Equivalent Unit, FEU)

B = 9.125 m

C = 6.085 m (Twenty Feet Equivalent Unit, TEU)

D = 2.991 m

E = 1.968 m

F = 1.460 m

Height Standards:

1X = 2.438 m (low cube)

1XX = 2.591 m (standard cube)

1XXX = 2.896 m (high cube)

Tolerances:

0.25 inches / 10 Feet

leading in reality to a 0.076 m (3 inch) space between the most common TEU containers

Further Information about freight containers are given in **Slawik, et al. (2010)** and the **GDV (2010)**.

System 2: Modular coordination current building unit system (e.g. Cadolto, Kleusberg, Alho)

Kadolto, Alho and Kleusberg allow architects to work within their modular coordination system and then take over the splitting up (modularization) and manufacturing of those units. However, besides the below mentioned “soft” standards (not laid down e.g. in an ISO specification) most companies, offer the manufacturing of any dimension for a slightly increased cost.

Length Standards:

18.00 m

16.75 m

15.25 m

14.00 m

12.75 m

11.50 m

10.25 m

9.00 m

7.75 m

6.50 m

Height Standards:

3.20 m

3.45 m

3.65 m

3.85 m

Width Standards:

2.625 m

3.25 m

3.875 m

4.25 m

6.00 m

Tolerances: depends on project

Further Information about freight containers are given by guidelines of Kadolto, Alho and Kleusberg.

System 3: A novel modular coordination system

Both of the above mentioned measurement systems have their strengths and weaknesses.

System 1: is part of a worldwide deployed logistics and transport infrastructure and compatible with almost any transport medium, except cargo planes (truck, trains, ships, helicopters). However, the measurement system is not suitable for generating room dimensions, as required for condominiums, offices, laboratories, hospitals, schools or homes for the elderly. Approach 4, outlined above (with one loop in x and one in y direction), also requires that unit length and width are based on a multiple of a common measurement unit – which is (also due to the “in-built” tolerance system) not the case.

System 2: is suitable for generating room dimensions as required for condominiums, offices, laboratories, hospitals, schools or homes for the elderly. However, the measurements are incompatible with the standard transport infrastructure and with the freight container coordination and corner fitting system. Research conducted by major Japanese LSP companies revealed that the shipping of units (with dimensions appropriate to building/room dimensions) in large scale from Japan to, for example, China or Europe would necessitate the engineering and construction of novel container ships and access points (**Sekisui Heim, 2008**). Also, the transport on land would be difficult and in most cases subject to ‘abnormal load transportation’ (heavy load, large load, wide load).

In Germany, for example, the following transportability standards are common:

- Standard Transport - Width: 2.50 m, height: 3 m, length 20 m
- Abnormal Transport license with approval for up to one year with unlimited transport numbers - Width: 3 m, height up to 4 m, length up to 23 m
- Abnormal Transport license with shorter or individual approval - Width more than 3 m, height up to 4 m, length up to 23 m or longer
- Abnormal Transport licenses with individual approval, combined with night time approval or necessity of police escort - Width over 3,20 m

In 2006, Cadalto shipped a whole hospital (Center Hospitalier Universitaire de Nancy) modularized into 40 units, 31 m long, 3.5 m wide and more than 3.0 m high, by truck convoy to Paris. *Figure 6-6* shows the station for loading large sized units onto special transport trucks. Abnormal Transport is possible and common practice practically worldwide. However, it is – depending on location, unit sizes and shipping distance – time consuming and costly in relation to the additional organisational issues.



Figure 6-6: station for loading large sized units onto special transport trucks. Cadolto, 2011. (Picture Source: Linner)

In order to be able to make use of the advantages of System 1 and System 2, while minimizing the associated disadvantages, a novel modular coordination system is suggested. Furthermore, the modular coordination system should take into consideration that transport and positioning loops operate in x- and y-directions (Approaches 4 and 5).

The proposed novel modular coordination system therefore has following specifications:

- Basic Measurement Unit (BMU): 1.2192 m
- BMU applies in x- and y-direction (length and width)
- 2 BMUs are equal to the standardized width of a freight container system
- 5 BMUs are equal to the length of a TEU container
- 10 BMUs are equal to the length of a FEU container
- Height is not standardized

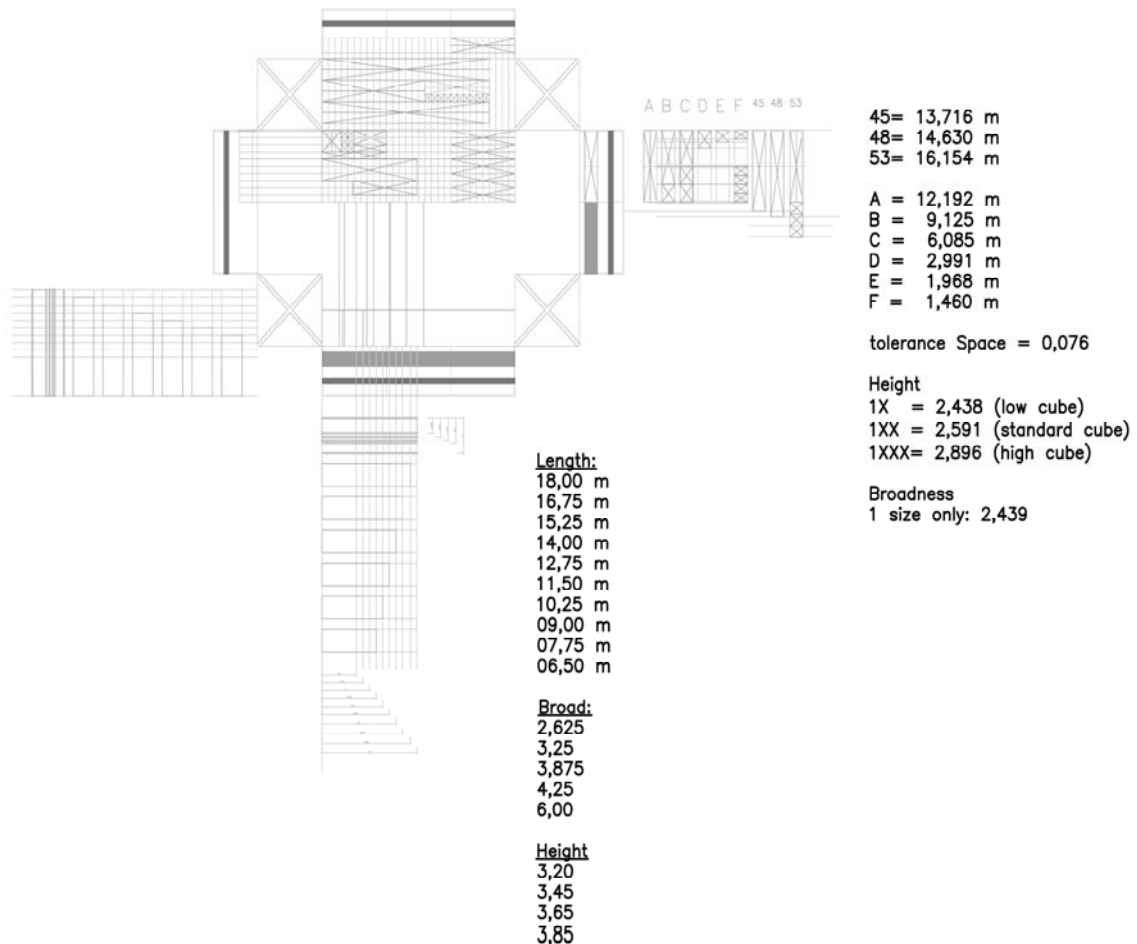

Figure 6-7: Analysis of various measurement unit systems. Right: container measurement system. Bottom: current building units measurement system, Top: BMU

The novel modular coordination system thus allows for following performance:

1. A unit's dimensions can be within the freight container system, or outside the freight container system
2. Smaller units (compatible with freight container systems) can be transported to the factory site or near the site, and be attached to larger units (BMU System)
3. Smaller units (compatible with freight container systems) can be transported to the factory site (GF) where they are attached to larger units (BMU System)
4. Standard freight container sized units (TEU and FEU) can be combined on-site (GF or top factory) with BMU-sized units
5. Units can be combined from x- and y-direction
6. If 3 BMU is chosen as the standard width processed by the transport and logistics loop, the units can be delivered completely by abnormal/special transportation or as smaller units and attached to 3 BMU wide units in a GF
7. Ships can deliver BMU sized units to ports near the site

As major cities with a huge demand for high-rise buildings are today located near the sea (Japan, Korea, Singapore, China, USA), ships could become floating factories that produce and deliver BMU-sized units to ports near the site.

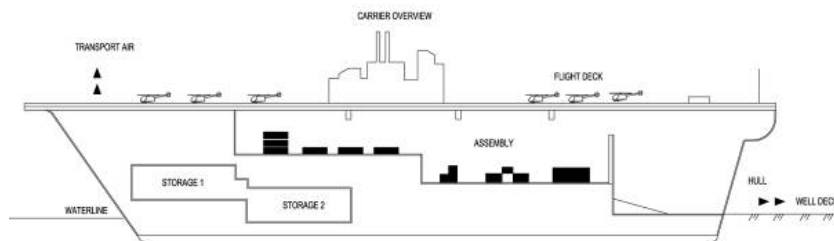

Figure 6-8: Mobile naval BMU manufacturing and delivering systems. Conversion of an aircraft carrier to a mobile naval BMU manufacturing and delivering system that is informationally directly integrated with the GF (Linner et al., 2010). Manufacturing takes place under the flight deck. Delivery of units to land or the site is possible via smaller transport ships and via helicopters or cargo airships.

Approach 5: Approach 5 builds fully on a full synchronization of building, construction technology (target system) and building blocks (unit) with the BMU measurement systems. The system picks up in the GF units with a width of 3 BMU, and maximum length (length between the superstructure corners of the building). The automatic processing of units with maximum length by the loop transportation and positioning system allows for lifting operations, as well as positioning adjusting operations, in the top factory are reduced to a minimum. The units with 3 BMU width and maximum length are either delivered directly to the site JIT and JIS or put together by smaller units in the GF.

The units are also directly positioned by the two-loop systems and not distributed over a platform as in Approach 4. The superstructure corners are constructed by an automated tower erection system (similar to TS-UP or SMART-Tower) with 2-5 levels in advance. The four towers can then be used to pull up the two loops step-by-step (similar to the pulling up of working platforms in the T-Up system and RCACS. One difference: multiple cores). Furthermore, the two loops can work in parallel as one works in x-direction and the other in x-direction, but on different levels both in the ground-factory and top-factory. The loops are attached from the outside to the building's superstructure and can be removed after completion of the building. The frames, of which the loop is a part, are designed so that the forces occurring when robotic trolley hoists ("crabs") travel in the system are partly transferred to the building. The loops' frame system can thus be lightweight and easier to push/lift up and transport to and/or remove from the site.

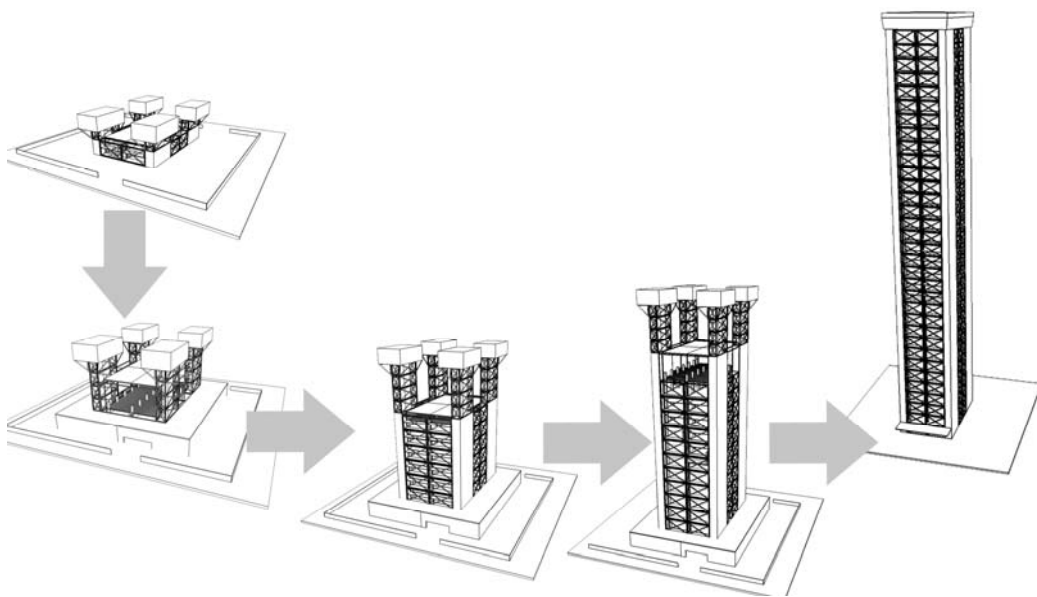

Figure 6-9: Visualization of evolution scheme of the system proposed by Approach 5 (for further details see A0 plan "Approach to real-time and building-integrated automated Construction")

Following Terminology is necessary:

1. **Superstructure Tower Site Factory (STSF):** constructs the four corner superstructure
2. **GF (GF):** factory on ground where 3 BMU wide and maximum length units are prepared for pickup by "crabs" – GF is directly integrated with transportation loops
3. **Girder and Standard Floor Sky Factory (GSSF):** factory system on top - directly integrated with TLs
4. **Transportation Loops (TL):** vertical transportation channels – integrated with GF and GSSF

5. **Crabs:** trolley hoists picking up, transporting and positioning the units and superstructure girders

With the presented approach, the capacity of the GF and the possibility of rapidly installing or dismantling it would become a key technology. The Mobile Parts Hospital (MPH) approach as well as the Mobile Field Factory (MFF) approach (see **2.3**) can be the starting position for the development of the GF. The GF could be set-up up and disassembled rapidly, combining a multitude of MPGs or MFFs on-site to a full capacity Toyota Home-like final assembly line for units.

6.1.10 Sensor systems and AAMS

In **2.4** it was outlined that machine systems (including automated systems and robotic systems) can be equipped with a multitude of proprioceptive (internal) sensor systems and exteroceptive (external) sensor systems for measuring and interpreting data. Sensor systems are relevant for the autonomy of the system as well as for the achievement of a certain degree of accuracy or repeatability. The synchronization of the complexity of the sensor, process measurement technology (and thus its cost and robustness) with the structure of machines, processes and building elements is a key issue of ROD (reduction of sensor, process measuring and control technology, see also **6.2.5**, below). Furthermore, the analysis of the efficiency of the current generation of automated construction sites (see **5.4**) showed, that on the one hand, fully automated and highly accurate sensor guided positioning operations reduced the amount of human supervisors necessary on-site, but on the other hand, reduced the processing speed of the systems. All in all, different strategies to achieve positioning/alignment accuracy by an automated or partly automated system can be chosen. The decisions over which strategies to choose shall be related to the overall concept (speed required, robustness required, etc.) as well as to the availability of a certain set of technologies for a firm in a certain economic environment.

- **Mainly mechanical AAMS:** The pick-up as well as the positioning, alignment and fixation of freight containers by crabs in the logistics industry can be identified as being mainly mechanical. During a container pick-up process, four movable wings at the four corners of the crabs guarantee a self-adjustment of the position of the crab to the necessary pick-up position of the twist-lock pins. The corner fittings of the containers further allow for a certain tolerance of 2-3 centimeters. The positioning process, which is also not sensor-guided, works with a tolerance of 0.25 inches per 10 Feet. Adjusting and fixation is accomplished by the twist-lock corner fitting system.

Similarly, other corner-fitting based positioning and alignment systems require tolerances of several centimeters (e.g. positioning/alignment of units by Sekisui Heim, and units by Kleusber requires per axis at least 0.5 centimeters per axis and unit; Cadolto 1.5 centimeters per axis and unit). The advantage of a mainly mechanically guided positioning and alignment process is its robustness, reduced

complexity of maintenance operations, reduced requirement of technical skill of supervisors and workers, and a reduced control, processing and informational complexity. On the other hand, the incorporation of a tolerance system into a measurement system (e.g. as BMU) enhances design and planning complexity. High tolerances might also be a problem for extremely high buildings, as inaccuracies can increase and multiply over a number of floors. Furthermore, tolerances and inaccuracies might negatively influence the controlled and predictable reaction of the high-rise building on vibrations caused by earth-quakes or by wind.

- **Mainly sensor guided AAMS:** In contrast to the mainly mechanically guided positioning and alignment, the sensor guided approach can reduce tolerances to a minimum. Additionally, the generated data would build a basis for efficient automation, supervision of construction progress and quality. Two basic strategies can be identified:
 - **Integration of the sensor-system with the pick-up/positioning system (GSSF, crabs):** This is the usual approach, for example, in the automotive industry. Machine systems, automated systems and robots are guided during positioning, alignment and fixation by global sensor systems such as 3-D vision systems or laser scanners. Current automated construction sites (e.g. ABCS) follow that approach.
 - **Integration of the sensor-systems with the components or units:** Sensor systems are directly integrated into the components or units as permanent systems. If a sensor system was not activated for possible rearrangement or deconstruction it would be a kind of “lost sensor system”. Extremely high accuracy could be achieved as an integrated sensor system in contrast to, for example, vision systems or laser systems integrated with crabs or GSSF could identify the 3-D alignment of the units without limitations by geometry and sight. The following technologies could be used:
 - Measuring of the alignment of the units of superstructure or other units by capacitance difference
 - Infrared system and triangulation
 - Geomagnetic field sensors
 - Integrated sensor systems can be designed as:
 - Lost sensor systems
 - Systems that can be reactivated in case of rearrangement or disassembly
 - Becoming part of the building automation systems, structural health monitoring systems or active/passive vibration control systems.
- **Hybrid-AAMS:** Combination of mechanical, sensor-guided and unit integrated positioning and alignment strategies and technologies.

Basically, of course, a variety of scenarios for the position determination is possible. The best option would probably be a combination of several systems to compensate for the shortcomings and disadvantages of single systems, and, secondly, to increase the reliability

and reproducibility of the measurements. For example, a high-precision 3-D scanner, which is capable of several measuring square meters, would be appropriate for the first positioning, wherein, in the final phase of the positioning and orientation of the component, small capacitive distance sensors (which are integrated at the corners or corner-fittings of the components or units) are suitable. The integrated sensor systems can easily be developed and produced on the basis of commercially available or even custom produced platforms.

The formulation of a basic process scenario and the definition of required tolerances would create a starting point. Based on that, the resulting accuracy, appropriate measuring equipment and measurement principles, can then be specified. Strategy and systems have to be chosen in a way that allows the minimizing of data gaps in the acquisition systems and measurement chain.

Table 6-1: Use of sensor systems to assist automated building manufacturing in various life-cycle phases.

1. Transport of components and units over the transportation loops:

- Unique identification of the components and units by appropriate readers makes efficient and failure free processing possible
-

2. Preliminary/rough positioning:

- Accurate measurement of the position of the units already installed, and the spacing to the unit to be installed, can be done by using a 3-D laser scanner.
 - Automated evaluation and control can be accomplished using the values derived from this measurement.
 - An advantage of this method is the possibility of a detailed analysis of the existing conditions in the area, including the identification of possible obstacles (parked tools, materials, people, etc.).
-

3. Fine positioning to achieve the final location/orientation:

- Activation of capacitive proximity sensors attached to the corners of the components and units. Data could be read without contact via NFC (Near Field Communication) or passive RFID-chips from the four corner sensors points.
 - Such sensors can be produced in large volumes at very low prices. Also, the customized production of adhesive RFID-strips would be possible when ordering large amounts.
 - Once the unit is positioned and aligned, all data about this can be stored in the RFID-chip (final location, installation time and date, etc.). Of particular interest, is the company "Scemtec", which designs and manufactures such kind of sensors (<http://www.scemtec.com>).
-

4. Installation of surrounding components and units:

- Possible compression and settlement processes that occur naturally in every large scale
-

construction can be measured precisely by the integrated RFID-measuring systems. Thus, it would be possible to precisely control the construction quality at any time.

5. Completion and handover of the building:

- The integrated RFID-measuring system could simplify both quality control and handover.
 - Handover allowances to put floors or units into operation can be created automatically, because the chips can record the installation process and automatically identify its accuracy and quality.
-

6. Life-cycle/use phase:

- During the first time after completion possible settlement processes can be monitored.
 - In emergencies, such as earthquakes, storms, fires and other natural disasters the integrated measurement systems can analyze the movements of the building and identify damages (including hidden aging processes such as corrosion).
 - More sensor capability could be helpful to monitor the behaviour of the building structure and possible damages during life cycle (eg temperature sensors). The RFID-measurement system could serve as central processing unit and reduce cost of any additional sensor system.
-

7. Rearrangement/Deconstruction:

- Unique identification of the components and units by appropriate readers makes possible an efficient and failure free rearrangement or deconstruction
 - RFID measurement system can identify sticking or rusted units and adjust the disassembly process.
 - Damaged attachment points can be avoided.
-

8. Recycling of the building:

- The information stored in the chip could provide important additional information, such as:
 - Building materials contained by components of units (urban mining)
 - Pollutants contained by components of units
 - Damage or repositioning e.g. through settlement processes or earthquakes, as information for crabs
 - The decision to continue using individual building blocks could be made (fully automatically) on the basis of information stored in the RFID-chips.
-

Basic system components for the realization of the above outlined scenario/process are commercially available. If large numbers are ordered, system components can be custom designed and manufactured.

Table 6-2: Available sensor technology,

Optical sensor systems for integration with manipulation systems	http://www.gom.com/de/messsysteme/systemuebersicht/atos-compact-scan.html accessed Sept. 2012 http://www.faro.com/content.aspx?ct=ge&content=pro&item=3 accessed Sept. 2012 http://www.micro-epsilon.de/laser-scanner-profile-sensor/index.html accessed Sept. 2012
Optical sensor systems for integration with building units	http://www.allsens.de/laser.html accessed Sept. 2012 http://www.micro-epsilon.de/displacement-position-sensors/laser-sensor/index.html accessed Sept. 2012
Capacitive sensor systems for integration with building units	http://www.micro-epsilon.de/displacement-position-sensors/capacitive-sensor/capaNCDT_6019/index.html accessed Sept. 2012 http://www.capacitec.com/index.cfm?pg=30 accessed Sept. 2012
Ultrasonic sensors for integration with manipulation systems	http://www.crautomation.com/ultra1a.htm accessed Sept. 2012
Contact switches for integration with building units	http://www.baumer.com/int-de/produkte/anwesenheitssensorik/kapazitive-sensoren/montageloesung-fuer-den-kapazitivsensor-cfdk-25/ accessed Sept. 2012
RFID systems for integration with building units	http://www.scemtec.com/scems/de/rfid_abstand.htm accessed Sept. 2012 http://www.rfid-ready.de/201007151908/korrosionserkennung-mit-rfid.html accessed Sept. 2012

6.1.11 Analysis of construction speed of variants of target system

Five Variants of Approach 5 were analyzed and the construction speed for each system was calculated (see *Construction Speed Comparison Table*).

- **Variant 1A and 1B:** Variants 1A and 1B are basically equal to the initial concept of Approach 5. The difference between these variants is that Variant 1A works with two loops whereas Variant 1B works with 4 loops, thus erasing the necessity to work on different levels in GF and GSSF.
- **Variant 2A and 2B:** Variants 2A and 2B finally integrate the transportation loop as part of the building and remove the necessity to deconstruct the transportation loop

system/frames after the completion of the building. Variant 2A works with two loops, variant 2B with four loops.

- **Variant 2B, optimized:** The analysis of construction speeds shows that the B-Variants with four loops are faster. Therefore Variant 2B is optimized and changes the building's configuration in order to optimize the operational sequence, and thus construction speed. In Variants 1B and 2B, one loop processes 14 units whereas the other variant only processes 6 units. This means that a complete parallelization of operations is not possible and that x-direction loops are over utilized and y-direction loops are underutilized. Variant 2B changes the configuration of the building so that all four loops are utilized by the same ratio and all ten positioning and adjusting operations remaining for each loop can be completely parallelized.

For a detailed visualization of the developed variants, see A0 plan *“Approach to real-time and building-integrated automated Construction”*.

It can be concluded that in order to achieve maximum performance of the target system, the following four parameters have to be fully synchronized with each other by BMU modular coordination:

1. Building dimensions and design
2. Construction technology
3. Building blocks
4. Operational sequence (construction)

The analysis of the evolution scheme will also show that the following two more parameters have to be added:

5. Operational Sequence (Upgrade during Use Phase)
6. Operational Sequence (Deconstruction)

6.1.12 Analysis of evolution scheme of target system

The analysis of the construction sequence plays a major role when designing an integrated automated construction site. The technical analysis of automated construction sites showed that the raising of the system and the parallel coordination with other operations (positioning of beams and columns, facade installation, facade work and sealing, interior finishing) on several floors was a central issue on each site. Furthermore, the trend towards building integrated maintenance robot systems and automated deconstruction shows that both life phase and deconstruction phases have to become part of the construction sequence analysis process in the development phase of integrated automated construction site technology.

Construction phase sequence (duration: 26 Days)

- Step 1: Installation of Superstructure Tower Site Factory (STSF)

- Step 2: Construction of superstructure ground floor (conventionally); production of further levels by STSF
- Step 3: Installation of Girder and Standard Floor Sky Factory (GSSF); beginning of Installation of GF
- Step 4: Production of superstructure second floor by GSSF; supply of components, JIT, by trucks
- Step 5: Raising of GSSF to next Level; completion of installation of GF and beginning of operation of GF
- Step 6: Beginning of production of standard floors in segment 1; supply of units by GF
- Step 7: Rise of GSSF; beginning of production of next Levels by STSF
- Step 8: Production of next standard floor by GSSF; in parallel, production of next Level by STSF; Repetition of step 7 and 8, 16 times
- Step 9: Production of superstructure girder level one 1 segment 2 by GSSF
- Step 10: Production of superstructure girder level one 1 segment 2 by GSSF
- Step 11: Repetition of steps 6-10 for segments 2-6
- Step 12: Disassembly of STSF
- Step 13: Use of GSSF as final superstructure girder level; disassembly of GF; storage of GSSF cranes (crabs) in basement level

Completion and Handover:

- Step 14: Completion and hand over of Building

Use Phase, Including Renovation/Upgrade:

- Step 15: GSSF cranes can be released from storage and enter lowerable platforms in each section through the superstructure; installation of temporary GF
- Step 16: Deconstruction of section
- Step 17: Installation of new units in a complete section

Deconstruction:

- Step 18: Reactivation of GSSF – picking up and lifting down of units; installation of GF for unit dismantling (reverse process of GF function during construction)
- Step 19: Installation of STSF for dismantling
- Step 20: Parallel deconstruction of superstructure by STSF, and standard floors by GSSF
- Step 21: Deconstruction of superstructure girders in each
- Step 22: End of dismantling operation by GSSF; beginning of de-installation of GF
- Step 23: Dismantling of GSSF and STSF

For a detailed visualization of the evolution scheme of the target system, see *A0 plan "Approach to real-time and building-integrated automated Construction"*.

Variant 1A - Standard Floors and Superstructure Girders Installation Speed

Number of modules takes into account parallel installation on-site by parallel Transportation Loops (TLs)

Standard floors

in minutes
in hours

Logistics from ground to operational floor					Positioning, adjusting, fixation on floor					GSSF rising	Toatal	
Floor level	Height of building	Length of building	Logistics distance	Logistics speed (m/min)	Logistics (min)	Number of modules	Positioning (min)	Adjusting (min)	Fixation (min)	Installation (min)	GSSF rising (min)	Toatal (min)
					694,1625					6848	6420	13962,1625
					11,569375					114,1333333	107	232,7027083
4	3,5	60	74	40	1,85	16	2	2	0	64	60	125,85
5	3,5	60	77,5	40	1,9375	16	2	2	0	64	60	125,9375
6	3,5	60	81	40	2,025	16	2	2	0	64	60	126,025
7	3,5	60	84,5	40	2,1125	16	2	2	0	64	60	126,1125
8	3,5	60	88	40	2,2	16	2	2	0	64	60	126,2
9	3,5	60	91,5	40	2,2875	16	2	2	0	64	60	126,2875
10	3,5	60	95	40	2,375	16	2	2	0	64	60	126,375
11	3,5	60	98,5	40	2,4625	16	2	2	0	64	60	126,4625
12	3,5	60	102	40	2,55	16	2	2	0	64	60	126,55
13	3,5	60	105,5	40	2,6375	16	2	2	0	64	60	126,6375
14	3,5	60	109	40	2,725	16	2	2	0	64	60	126,725
15	3,5	60	112,5	40	2,8125	16	2	2	0	64	60	126,8125
16	3,5	60	116	40	2,9	16	2	2	0	64	60	126,9
17	3,5	60	119,5	40	2,9875	16	2	2	0	64	60	126,9875
18	3,5	60	123	40	3,075	16	2	2	0	64	60	127,075
19	3,5	60	126,5	40	3,1625	16	2	2	0	64	60	127,1625
20	3,5	60	130	40	3,25	16	2	2	0	64	60	127,25
21	3,5	60	133,5	40	3,3375	16	2	2	0	64	60	127,3375
22	3,5	60	137	40	3,425	16	2	2	0	64	60	127,425
23	3,5	60	140,5	40	3,5125	16	2	2	0	64	60	127,5125
24	3,5	60	144	40	3,6	16	2	2	0	64	60	127,6
25	3,5	60	147,5	40	3,6875	16	2	2	0	64	60	127,6875
26	3,5	60	151	40	3,775	16	2	2	0	64	60	127,775
27	3,5	60	154,5	40	3,8625	16	2	2	0	64	60	127,8625
28	3,5	60	158	40	3,95	16	2	2	0	64	60	127,95
29	3,5	60	161,5	40	4,0375	16	2	2	0	64	60	128,0375
30	3,5	60	165	40	4,125	16	2	2	0	64	60	128,125
31	3,5	60	168,5	40	4,2125	16	2	2	0	64	60	128,2125
32	3,5	60	172	40	4,3	16	2	2	0	64	60	128,3
33	3,5	60	175,5	40	4,3875	16	2	2	0	64	60	128,3875
34	3,5	60	179	40	4,475	16	2	2	0	64	60	128,475
35	3,5	60	182,5	40	4,5625	16	2	2	0	64	60	128,5625
36	3,5	60	186	40	4,65	16	2	2	0	64	60	128,65
37	3,5	60	189,5	40	4,7375	16	2	2	0	64	60	128,7375
38	3,5	60	193	40	4,825	16	2	2	0	64	60	128,825
39	3,5	60	196,5	40	4,9125	16	2	2	0	64	60	128,9125
40	3,5	60	200	40	5	16	2	2	0	64	60	129
41	3,5	60	203,5	40	5,0875	16	2	2	0	64	60	129,0875
42	3,5	60	207	40	5,175	16	2	2	0	64	60	129,175
43	3,5	60	210,5	40	5,2625	16	2	2	0	64	60	129,2625
44	3,5	60	214	40	5,35	16	2	2	0	64	60	129,35
45	3,5	60	217,5	40	5,4375	16	2	2	0	64	60	129,4375
46	3,5	60	221	40	5,525	16	2	2	0	64	60	129,525
47	3,5	60	224,5	40	5,6125	16	2	2	0	64	60	129,6125
48	3,5	60	228	40	5,7	16	2	2	0	64	60	129,7
49	3,5	60	231,5	40	5,7875	16	2	2	0	64	60	129,7875
50	3,5	60	235	40	5,875	16	2	2	0	64	60	129,875
51	3,5	60	238,5	40	5,9625	16	2	2	0	64	60	129,9625
52	3,5	60	242	40	6,05	16	2	2	0	64	60	130,05
53	3,5	60	245,5	40	6,1375	16	2	2	0	64	60	130,1375
54	3,5	60	249	40	6,225	16	2	2	0	64	60	130,225
55	3,5	60	252,5	40	6,3125	16	2	2	0	64	60	130,3125
56	3,5	60	256	40	6,4	16	2	2	0	64	60	130,4
57	3,5	60	259,5	40	6,4875	16	2	2	0	64	60	130,4875
58	3,5	60	263	40	6,575	16	2	2	0	64	60	130,575
59	3,5	60	266,5	40	6,6625	16	2	2	0	64	60	130,6625
60	3,5	60	270	40	6,75	16	2	2	0	64	60	130,75
61	3,5	60	273,5	40	6,8375	16	2	2	0	64	60	130,8375
62	3,5	60	277	40	6,925	16	2	2	0	64	60	130,925
63	3,5	60	280,5	40	7,0125	16	2	2	0	64	60	131,0125
64	3,5	60	284	40	7,1	16	2	2	0	64	60	131,1
65	3,5	60	287,5	40	7,1875	16	2	2	0	64	60	131,1875
66	3,5	60	291	40	7,275	16	2	2	0	64	60	131,275
67	3,5	60	294,5	40	7,3625	16	2	2	0	64	60	131,3625
68	3,5	60	298	40	7,45	16	2	2	0	64	60	131,45
69	3,5	60	301,5	40	7,5375	16	2	2	0	64	60	131,5375
70	3,5	60	305	40	7,625	16	2	2	0	64	60	131,625
71	3,5	60	308,5	40	7,7125	16	2	2	0	64	60	131,7125
72	3,5	60	312	40	7,8	16	2	2	0	64	60	131,8
73	3,5	60	315,5	40	7,8875	16	2	2	0	64	60	131,8875
74	3,5	60	319	40	7,975	16	2	2	0	64	60	131,975
75	3,5	60	322,5	40	8,0625	16	2	2	0	64	60	132,0625
76	3,5	60	326	40	8,15	16	2	2	0	64	60	132,15
77	3,5	60	329,5	40	8,2375	16	2	2	0	64	60	132,2375
78	3,5	60	333	40	8,325	16	2	2	0	64	60	132,325
79	3,5	60	336,5	40	8,4125	16	2	2	0	64	60	132,4125
80	3,5	60	340	40	8,5	16	2	2	0	64	60	132,5
81	3,5	60	343,5	40	8,5875	16	2	2	0	64	60	132,5875
82	3,5	60	347	40	8,675	16	2	2	0	64	60	132,675
83	3,5	60	350,5	40	8,7625	16	2	2	0	64	60	132,7625
84	3,5	60	354	40	8,85	16	2	2	0	64	60	132,85
85	3,5	60	357,5	40	8,9375	16	2	2	0	64	60	132,9375
86	3,5	60	361	40	9,025	16	2	2	0	64	60	133,025
87	3,5	60	364,5	40	9,1125	16	2	2	0	64	60	133,1125
88	3,5	60	368	40	9,2	16	2	2	0	64	60	133,2
89	3,5	60	371,5	40	9,2875	16	2	2	0	64	60	133,2875
90	3,5	60	375	40	9,375	16	2	2	0	64	60	133,375
91	3,5	60	378,5	40	9,4625	16	2	2	0	64	60	133,4625
92	3,5	60	382	40	9,55	16	2	2	0	64	60	133,55
93	3,5	60	385,5	40	9,6375	16	2	2	0	64	60	133,6375
94	3,5	60	389	40	9,725	16	2	2	0	64	60	133,725
95	3,5	60	392,5	40	9,8125	16	2	2	0	64	60	133,8125
96	3,5	60	396	40	9,9	16	2	2	0	64	60	133,9
97	3,5	60	399,5	40	9,9875	16	2	2	0	64	60	133,9875
98	3,5	60	403	40	10,075	16	2	2	0	64	60	134,075
99	3,5	60	406,5	40	10,1625	16	2	2	0	64	60	134,1625
100	3,5	60	410	40	10,25	16	2	2	0	64	60	134,25
101	3,5	60	413,5	40	10,3375	16	2	2	0	64	60	134,3375
102	3,5	60	417	40	10,425	16	2	2				

Superstructure Girders

in minutes
in hours

					77,4						880	660	1617,4
					1,29						14,66666667	11	26,95666667
20	3,5	60	130	40	3,25	1	10	10	60	80	60	143,25	
22	3,5	60	137	40	3,425	1	10	10	60	80	60	143,425	
38	3,5	60	193	40	4,825	1	10	10	60	80	60	144,825	
40	3,5	60	200	40	5	1	10	10	60	80	60	145	
58	3,5	60	263	40	6,575	1	10	10	60	80	60	146,575	
60	3,5	60	270	40	6,75	1	10	10	60	80	60	146,75	
78	3,5	60	333	40	8,325	1	10	10	60	80	60	148,325	
80	3,5	60	340	40	8,5	1	10	10	60	80	60	148,5	
98	3,5	60	403	40	10,075	1	10	10	60	80	60	150,075	
100	3,5	60	410	40	10,25	1	10	10	60	80	60	150,25	
102	3,5	60	417	40	10,425	1	10	10	60	80	60	150,425	

1,12319444 days

Variant 1B - Standard Floors and Superstructure Girders Installation Speed

Number of modules takes into account parallel installation on-site by parallel Transportation Loops (TLs)

Standard floors

in minutes
in hours

Floor level	Height of building	Length of building	Logistics from ground to operation floor			Positioning, adjusting, fixation on floor					GSSF rising	Total
			Logistics distance	Logistics speed (m/min)	Logistics (min)	Number of modules	Positioning (min)	Adjusting (min)	Fixation (min)	Installation (min)	GSSF rising (min)	Total (min)
					347,08125					6848	6420	13615,08125
					5,7846875					114,1333333	107	226,9180208
4	3,5	60	74	80	0,925	16	2	2	0	64	60	124,925
5	3,5	60	77,5	80	0,96875	16	2	2	0	64	60	124,96875
6	3,5	60	81	80	1,0125	16	2	2	0	64	60	125,0125
7	3,5	60	84,5	80	1,05625	16	2	2	0	64	60	125,05625
8	3,5	60	88	80	1,1	16	2	2	0	64	60	125,1
9	3,5	60	91,5	80	1,14375	16	2	2	0	64	60	125,14375
10	3,5	60	95	80	1,1875	16	2	2	0	64	60	125,1875
11	3,5	60	98,5	80	1,23125	16	2	2	0	64	60	125,23125
12	3,5	60	102	80	1,275	16	2	2	0	64	60	125,275
13	3,5	60	105,5	80	1,31875	16	2	2	0	64	60	125,31875
14	3,5	60	109	80	1,3625	16	2	2	0	64	60	125,3625
15	3,5	60	112,5	80	1,40625	16	2	2	0	64	60	125,40625
16	3,5	60	116	80	1,45	16	2	2	0	64	60	125,45
17	3,5	60	119,5	80	1,49375	16	2	2	0	64	60	125,49375
18	3,5	60	123	80	1,5375	16	2	2	0	64	60	125,5375
19	3,5	60	126,5	80	1,58125	16	2	2	0	64	60	125,58125
20	3,5	60	130	80	1,625	16	2	2	0	64	60	125,625
21	3,5	60	133,5	80	1,66875	16	2	2	0	64	60	125,66875
22	3,5	60	137	80	1,7125	16	2	2	0	64	60	125,7125
23	3,5	60	140,5	80	1,75625	16	2	2	0	64	60	125,75625
24	3,5	60	144	80	1,8	16	2	2	0	64	60	125,8
25	3,5	60	147,5	80	1,84375	16	2	2	0	64	60	125,84375
26	3,5	60	151	80	1,8875	16	2	2	0	64	60	125,8875
27	3,5	60	154,5	80	1,93125	16	2	2	0	64	60	125,93125
28	3,5	60	158	80	1,975	16	2	2	0	64	60	125,975
29	3,5	60	161,5	80	2,01875	16	2	2	0	64	60	126,01875
30	3,5	60	165	80	2,0625	16	2	2	0	64	60	126,0625
31	3,5	60	168,5	80	2,10625	16	2	2	0	64	60	126,10625
32	3,5	60	172	80	2,15	16	2	2	0	64	60	126,15
33	3,5	60	175,5	80	2,19375	16	2	2	0	64	60	126,19375
34	3,5	60	179	80	2,2375	16	2	2	0	64	60	126,2375
35	3,5	60	182,5	80	2,28125	16	2	2	0	64	60	126,28125
36	3,5	60	186	80	2,325	16	2	2	0	64	60	126,325
37	3,5	60	189,5	80	2,36875	16	2	2	0	64	60	126,36875
38	3,5	60	193	80	2,4125	16	2	2	0	64	60	126,4125
39	3,5	60	196,5	80	2,45625	16	2	2	0	64	60	126,45625
40	3,5	60	200	80	2,5	16	2	2	0	64	60	126,5
41	3,5	60	203,5	80	2,54375	16	2	2	0	64	60	126,54375
42	3,5	60	207	80	2,5875	16	2	2	0	64	60	126,5875
43	3,5	60	210,5	80	2,63125	16	2	2	0	64	60	126,63125
44	3,5	60	214	80	2,675	16	2	2	0	64	60	126,675
45	3,5	60	217,5	80	2,71875	16	2	2	0	64	60	126,71875
46	3,5	60	221	80	2,7625	16	2	2	0	64	60	126,7625
47	3,5	60	224,5	80	2,80625	16	2	2	0	64	60	126,80625
48	3,5	60	228	80	2,85	16	2	2	0	64	60	126,85
49	3,5	60	231,5	80	2,89375	16	2	2	0	64	60	126,89375
50	3,5	60	235	80	2,9375	16	2	2	0	64	60	126,9375
51	3,5	60	238,5	80	2,98125	16	2	2	0	64	60	126,98125
52	3,5	60	242	80	3,025	16	2	2	0	64	60	127,025
53	3,5	60	245,5	80	3,06875	16	2	2	0	64	60	127,06875
54	3,5	60	249	80	3,1125	16	2	2	0	64	60	127,1125
55	3,5	60	252,5	80	3,15625	16	2	2	0	64	60	127,15625
56	3,5	60	256	80	3,2	16	2	2	0	64	60	127,2
57	3,5	60	259,5	80	3,24375	16	2	2	0	64	60	127,24375
58	3,5	60	263	80	3,2875	16	2	2	0	64	60	127,2875
59	3,5	60	266,5	80	3,33125	16	2	2	0	64	60	127,33125
60	3,5	60	270	80	3,375	16	2	2	0	64	60	127,375
61	3,5	60	273,5	80	3,41875	16	2	2	0	64	60	127,41875
62	3,5	60	277	80	3,4625	16	2	2	0	64	60	127,4625
63	3,5	60	280,5	80	3,50625	16	2	2	0	64	60	127,50625
64	3,5	60	284	80	3,55	16	2	2	0	64	60	127,55
65	3,5	60	287,5	80	3,59375	16	2	2	0	64	60	127,59375
66	3,5	60	291	80	3,6375	16	2	2	0	64	60	127,6375
67	3,5	60	294,5	80	3,68125	16	2	2	0	64	60	127,68125
68	3,5	60	298	80	3,725	16	2	2	0	64	60	127,725
69	3,5	60	301,5	80	3,76875	16	2	2	0	64	60	127,76875
70	3,5	60	305	80	3,8125	16	2	2	0	64	60	127,8125
71	3,5	60	308,5	80	3,85625	16	2	2	0	64	60	127,85625
72	3,5	60	312	80	3,9	16	2	2	0	64	60	127,9
73	3,5	60	315,5	80	3,94375	16	2	2	0	64	60	127,94375
74	3,5	60	319	80	3,9875	16	2	2	0	64	60	127,9875
75	3,5	60	322,5	80	4,03125	16	2	2	0	64	60	128,03125
76	3,5	60	326	80	4,075	16	2	2	0	64	60	128,075
77	3,5	60	329,5	80	4,11875	16	2	2	0	64	60	128,11875
78	3,5	60	333	80	4,1625	16	2	2	0	64	60	128,1625
79	3,5	60	336,5	80	4,20625	16	2	2	0	64	60	128,20625
80	3,5	60	340	80	4,25	16	2	2	0	64	60	128,25
81	3,5	60	343,5	80	4,29375	16	2	2	0	64	60	128,29375
82	3,5	60	347	80	4,3375	16	2	2	0	64	60	128,3375
83	3,5	60	350,5	80	4,38125	16	2	2	0	64	60	128,38125
84	3,5	60	354	80	4,425	16	2	2	0	64	60	128,425
85	3,5	60	357,5	80	4,46875	16	2	2	0	64	60	128,46875
86	3,5	60	361	80	4,5125	16	2	2	0	64	60	128,5125
87	3,5	60	364,5	80	4,55625	16	2	2	0	64	60	128,55625
88	3,5	60	368	80	4,6	16	2	2	0	64	60	128,6
89	3,5	60	371,5	80	4,64375	16	2	2	0	64	60	128,64375
90	3,5	60	375	80	4,6875	16	2	2	0	64	60	128,6875
91	3,5	60	378,5	80	4,73125	16	2	2	0	64	60	128,73125
92	3,5	60	382	80	4,775	16	2	2	0	64	60	128,775
93	3,5	60	385,5	80	4,81875	16	2	2	0	64	60	128,81875
94	3,5	60	389	80	4,8625	16	2	2	0	64	60	128,8625
95	3,5	60	392,5	80	4,90625	16	2	2	0	64	60	128,90625
96	3,5	60	396	80	4,95	16	2	2	0	64	60	128,95
97	3,5	60	399,5	80	4,99375	16	2	2	0	64	60	128,99375
98	3,5	60	403	80	5,0375	16	2	2	0	64	60	129,0375
99	3,5	60	406,5	80	5,08125	16	2	2	0	64	60	129,08125
100	3,5	60	410	80	5,125	16	2	2	0	64	60	129,125
101	3											

Superstructure Girders

in minutes
in hours

					39,625						960	720	1719,625
					0,660416667						16	12	28,66041667
4	3,5	60	74	80	0,925	1	10	10	60	80	60	60	140,925
20	3,5	60	130	80	1,625	1	10	10	60	80	60	60	141,625
22	3,5	60	137	80	1,7125	1	10	10	60	80	60	60	141,7125
38	3,5	60	193	80	2,4125	1	10	10	60	80	60	60	142,4125
40	3,5	60	200	80	2,5	1	10	10	60	80	60	60	142,5
58	3,5	60	263	80	3,2875	1	10	10	60	80	60	60	143,2875
60	3,5	60	270	80	3,375	1	10	10	60	80	60	60	143,375
78	3,5	60	333	80	4,1625	1	10	10	60	80	60	60	144,1625
80	3,5	60	340	80	4,25	1	10	10	60	80	60	60	144,25
98	3,5	60	403	80	5,0375	1	10	10	60	80	60	60	145,0375
100	3,5	60	410	80	5,125	1	10	10	60	80	60	60	145,125
102	3,5	60	417	80	5,2125	1	10	10	60	80	60	60	145,2125

1,19418403 days

Variant 2A - Standard Floors and Superstructure Girders Installation Speed

Number of modules takes into account parallel installation on-site by parallel Transportation Loops (TLs)

Standard floors

in minutes
in hours

Logistics from ground to operational floor					Positioning, adjusting, fixation on floor					GSSF rising	Total	
Floor level	Height of building	Length of building	Logistics distance	Logistics speed (m/min)	Logistics (min)	Number of modules	Positioning (min)	Adjusting (min)	Fixation (min)	Installation (min)	GSSF rising (min)	Total (min)
					694,1625 11,569375					5992 99,86666667	4280 71,33333333	10966,1625 182,769375
												7,615390625 days
4	3,5	60	74	40	1,85	14	2	2	0	56	40	97,85
5	3,5	60	77,5	40	1,9375	14	2	2	0	56	40	97,9375
6	3,5	60	81	40	2,025	14	2	2	0	56	40	98,025
7	3,5	60	84,5	40	2,1125	14	2	2	0	56	40	98,1125
8	3,5	60	88	40	2,2	14	2	2	0	56	40	98,2
9	3,5	60	91,5	40	2,2875	14	2	2	0	56	40	98,2875
10	3,5	60	95	40	2,375	14	2	2	0	56	40	98,375
11	3,5	60	98,5	40	2,4625	14	2	2	0	56	40	98,4625
12	3,5	60	102	40	2,55	14	2	2	0	56	40	98,55
13	3,5	60	105,5	40	2,6375	14	2	2	0	56	40	98,6375
14	3,5	60	109	40	2,725	14	2	2	0	56	40	98,725
15	3,5	60	112,5	40	2,8125	14	2	2	0	56	40	98,8125
16	3,5	60	116	40	2,9	14	2	2	0	56	40	98,9
17	3,5	60	119,5	40	2,9875	14	2	2	0	56	40	98,9875
18	3,5	60	123	40	3,075	14	2	2	0	56	40	99,075
19	3,5	60	126,5	40	3,1625	14	2	2	0	56	40	99,1625
20	3,5	60	130	40	3,25	14	2	2	0	56	40	99,25
21	3,5	60	133,5	40	3,3375	14	2	2	0	56	40	99,3375
22	3,5	60	137	40	3,425	14	2	2	0	56	40	99,425
23	3,5	60	140,5	40	3,5125	14	2	2	0	56	40	99,5125
24	3,5	60	144	40	3,6	14	2	2	0	56	40	99,6
25	3,5	60	147,5	40	3,6875	14	2	2	0	56	40	99,6875
26	3,5	60	151	40	3,775	14	2	2	0	56	40	99,775
27	3,5	60	154,5	40	3,8625	14	2	2	0	56	40	99,8625
28	3,5	60	158	40	3,95	14	2	2	0	56	40	99,95
29	3,5	60	161,5	40	4,0375	14	2	2	0	56	40	100,0375
30	3,5	60	165	40	4,125	14	2	2	0	56	40	100,125
31	3,5	60	168,5	40	4,2125	14	2	2	0	56	40	100,2125
32	3,5	60	172	40	4,3	14	2	2	0	56	40	100,3
33	3,5	60	175,5	40	4,3875	14	2	2	0	56	40	100,3875
34	3,5	60	179	40	4,475	14	2	2	0	56	40	100,475
35	3,5	60	182,5	40	4,5625	14	2	2	0	56	40	100,5625
36	3,5	60	186	40	4,65	14	2	2	0	56	40	100,65
37	3,5	60	189,5	40	4,7375	14	2	2	0	56	40	100,7375
38	3,5	60	193	40	4,825	14	2	2	0	56	40	100,825
39	3,5	60	196,5	40	4,9125	14	2	2	0	56	40	100,9125
40	3,5	60	200	40	5	14	2	2	0	56	40	101
41	3,5	60	203,5	40	5,0875	14	2	2	0	56	40	101,0875
42	3,5	60	207	40	5,175	14	2	2	0	56	40	101,175
43	3,5	60	210,5	40	5,2625	14	2	2	0	56	40	101,2625
44	3,5	60	214	40	5,35	14	2	2	0	56	40	101,35
45	3,5	60	217,5	40	5,4375	14	2	2	0	56	40	101,4375
46	3,5	60	221	40	5,525	14	2	2	0	56	40	101,525
47	3,5	60	224,5	40	5,6125	14	2	2	0	56	40	101,6125
48	3,5	60	228	40	5,7	14	2	2	0	56	40	101,7
49	3,5	60	231,5	40	5,7875	14	2	2	0	56	40	101,7875
50	3,5	60	235	40	5,875	14	2	2	0	56	40	101,875
51	3,5	60	238,5	40	5,9625	14	2	2	0	56	40	101,9625
52	3,5	60	242	40	6,05	14	2	2	0	56	40	102,05
53	3,5	60	245,5	40	6,1375	14	2	2	0	56	40	102,1375
54	3,5	60	249	40	6,225	14	2	2	0	56	40	102,225
55	3,5	60	252,5	40	6,3125	14	2	2	0	56	40	102,3125
56	3,5	60	256	40	6,4	14	2	2	0	56	40	102,4
57	3,5	60	259,5	40	6,4875	14	2	2	0	56	40	102,4875
58	3,5	60	263	40	6,575	14	2	2	0	56	40	102,575
59	3,5	60	266,5	40	6,6625	14	2	2	0	56	40	102,6625
60	3,5	60	270	40	6,75	14	2	2	0	56	40	102,75
61	3,5	60	273,5	40	6,8375	14	2	2	0	56	40	102,8375
62	3,5	60	277	40	6,925	14	2	2	0	56	40	102,925
63	3,5	60	280,5	40	7,0125	14	2	2	0	56	40	103,0125
64	3,5	60	284	40	7,1	14	2	2	0	56	40	103,1
65	3,5	60	287,5	40	7,1875	14	2	2	0	56	40	103,1875
66	3,5	60	291	40	7,275	14	2	2	0	56	40	103,275
67	3,5	60	294,5	40	7,3625	14	2	2	0	56	40	103,3625
68	3,5	60	298	40	7,45	14	2	2	0	56	40	103,45
69	3,5	60	301,5	40	7,5375	14	2	2	0	56	40	103,5375
70	3,5	60	305	40	7,625	14	2	2	0	56	40	103,625
71	3,5	60	308,5	40	7,7125	14	2	2	0	56	40	103,7125
72	3,5	60	312	40	7,8	14	2	2	0	56	40	103,8
73	3,5	60	315,5	40	7,8875	14	2	2	0	56	40	103,8875
74	3,5	60	319	40	7,975	14	2	2	0	56	40	103,975
75	3,5	60	322,5	40	8,0625	14	2	2	0	56	40	104,0625
76	3,5	60	326	40	8,15	14	2	2	0	56	40	104,15
77	3,5	60	329,5	40	8,2375	14	2	2	0	56	40	104,2375
78	3,5	60	333	40	8,325	14	2	2	0	56	40	104,325
79	3,5	60	336,5	40	8,4125	14	2	2	0	56	40	104,4125
80	3,5	60	340	40	8,5	14	2	2	0	56	40	104,5
81	3,5	60	343,5	40	8,5875	14	2	2	0	56	40	104,5875
82	3,5	60	347	40	8,675	14	2	2	0	56	40	104,675
83	3,5	60	350,5	40	8,7625	14	2	2	0	56	40	104,7625
84	3,5	60	354	40	8,85	14	2	2	0	56	40	104,85
85	3,5	60	357,5	40	8,9375	14	2	2	0	56	40	104,9375
86	3,5	60	361	40	9,025	14	2	2	0	56	40	105,025
87	3,5	60	364,5	40	9,1125	14	2	2	0	56	40	105,1125
88	3,5	60	368	40	9,2	14	2	2	0	56	40	105,2
89	3,5	60	371,5	40	9,2875	14	2	2	0	56	40	105,2875
90	3,5	60	375	40	9,375	14	2	2	0	56	40	105,375
91	3,5	60	378,5	40	9,4625	14	2	2	0	56	40	105,4625
92	3,5	60	382	40	9,55	14	2	2	0	56	40	105,55
93	3,5	60	385,5	40	9,6375	14	2	2	0	56	40	105,6375
94	3,5	60	389	40	9,725	14	2	2	0	56	40	105,725
95	3,5	60	392,5	40	9,8125	14	2	2	0	56	40	105,8125
96	3,5	60	396	40	9,9	14	2	2	0	56	40	105,9
97	3,5	60	399,5	40	9,9875	14	2	2	0	56	40	105,9875
98	3,5	60	403	40	10,075	14	2	2	0	56	40	106,075
99	3,5	60	406,5	40	10,1625	14	2	2	0	56	40	106,1625
100	3,5	60	410	40	10,25	14	2	2	0	56	40	106,25
101	3,5	60	413,5	40	10,3375	14	2	2	0	56	40	106,3375
102	3,5	60	417	40	10,425	14	2	2	0	56	40	106,425
103	3,5	60	420,5	40	10,5125	14	2	2	0	56	40	106,5125
104	3,5	60	424	40	10,6	14	2	2	0	56	40	106,6
105	3,5	60	427,5	40	10,6875	14	2	2	0	56	40	106,6875
106	3,5	60	431	40	10,775	14	2	2	0	56	40	106,775
107	3,5	60	434,5	40	10,8625	14	2	2	0	56	40	106,8625
108	3,5	60	438	40	10,95	14	2	2	0	56	40	106,95
109	3,5	60	441,5	40	11,0375	14	2	2	0	56	40	107,0375
110	3,5	60	445	40	11,125	14	2	2	0	56	40	107,125

Superstructure Girders

in minutes
in hours

					77,4						880	440	1397,4	
					1,29						14,66666667	7,333333333	23,29	0,970416667 days
20	3,5	60	130	40	3,25	1	10	10	60	80	40		123,25	
22	3,5	60	137	40	3,425	1	10	10	60	80	40		123,425	
38	3,5	60	193	40	4,825	1	10	10	60	80	40		124,825	
40	3,5	60	200	40	5	1	10	10	60	80	40		125	
58	3,5	60	263	40	6,575	1	10	10	60	80	40		126,575	
60	3,5	60	270	40	6,75	1	10	10	60	80	40		126,75	
78	3,5	60	333	40	8,325	1	10	10	60	80	40		128,325	
80	3,5	60	340	40	8,5	1	10	10	60	80	40		128,5	
98	3,5	60	403	40	10,075	1	10	10	60	80	40		130,075	
100	3,5	60	410	40	10,25	1	10	10	60	80	40		130,25	
102	3,5	60	417	40	10,425	1	10	10	60	80	40		130,425	

Variant 2B - Standard Floors and Superstructure Girders Installation Speed

Number of modules takes into account parallel Installation on-site by parallel Transportation Loops (TLs)

Standard floors

in minutes
in hours

Logistics from ground to operational floor					Positioning, adjusting, fixation on floor					GSSF rising	Total	
Floor level	Height of building	Length of building	Logistics distance	Logistics speed (m/min)	Logistics (min)	Number of modules	Positioning (min)	Adjusting (min)	Fixation (min)	Installation (min)	GSSF rising (min)	Total (min)
					347,08125					6848	4280	11475,08125
					5,7846875					114,1333333	71,3333333	191,2513542
4	3,5	60	74	80	0,925	16	2	2	0	64	40	104,925
5	3,5	60	77,5	80	0,96875	16	2	2	0	64	40	104,96875
6	3,5	60	81	80	1,0125	16	2	2	0	64	40	105,0125
7	3,5	60	84,5	80	1,05625	16	2	2	0	64	40	105,05625
8	3,5	60	88	80	1,1	16	2	2	0	64	40	105,1
9	3,5	60	91,5	80	1,14375	16	2	2	0	64	40	105,14375
10	3,5	60	95	80	1,1875	16	2	2	0	64	40	105,1875
11	3,5	60	98,5	80	1,23125	16	2	2	0	64	40	105,23125
12	3,5	60	102	80	1,275	16	2	2	0	64	40	105,275
13	3,5	60	105,5	80	1,31875	16	2	2	0	64	40	105,31875
14	3,5	60	109	80	1,3625	16	2	2	0	64	40	105,3625
15	3,5	60	112,5	80	1,40625	16	2	2	0	64	40	105,40625
16	3,5	60	116	80	1,45	16	2	2	0	64	40	105,45
17	3,5	60	119,5	80	1,49375	16	2	2	0	64	40	105,49375
18	3,5	60	123	80	1,5375	16	2	2	0	64	40	105,5375
19	3,5	60	126,5	80	1,58125	16	2	2	0	64	40	105,58125
20	3,5	60	130	80	1,625	16	2	2	0	64	40	105,625
21	3,5	60	133,5	80	1,66875	16	2	2	0	64	40	105,66875
22	3,5	60	137	80	1,7125	16	2	2	0	64	40	105,7125
23	3,5	60	140,5	80	1,75625	16	2	2	0	64	40	105,75625
24	3,5	60	144	80	1,8	16	2	2	0	64	40	105,8
25	3,5	60	147,5	80	1,84375	16	2	2	0	64	40	105,84375
26	3,5	60	151	80	1,8875	16	2	2	0	64	40	105,8875
27	3,5	60	154,5	80	1,93125	16	2	2	0	64	40	105,93125
28	3,5	60	158	80	1,975	16	2	2	0	64	40	105,975
29	3,5	60	161,5	80	2,01875	16	2	2	0	64	40	106,01875
30	3,5	60	165	80	2,0625	16	2	2	0	64	40	106,0625
31	3,5	60	168,5	80	2,10625	16	2	2	0	64	40	106,10625
32	3,5	60	172	80	2,15	16	2	2	0	64	40	106,15
33	3,5	60	175,5	80	2,19375	16	2	2	0	64	40	106,19375
34	3,5	60	179	80	2,2375	16	2	2	0	64	40	106,2375
35	3,5	60	182,5	80	2,28125	16	2	2	0	64	40	106,28125
36	3,5	60	186	80	2,325	16	2	2	0	64	40	106,325
37	3,5	60	189,5	80	2,36875	16	2	2	0	64	40	106,36875
38	3,5	60	193	80	2,4125	16	2	2	0	64	40	106,4125
39	3,5	60	196,5	80	2,45625	16	2	2	0	64	40	106,45625
40	3,5	60	200	80	2,5	16	2	2	0	64	40	106,5
41	3,5	60	203,5	80	2,54375	16	2	2	0	64	40	106,54375
42	3,5	60	207	80	2,5875	16	2	2	0	64	40	106,5875
43	3,5	60	210,5	80	2,63125	16	2	2	0	64	40	106,63125
44	3,5	60	214	80	2,675	16	2	2	0	64	40	106,675
45	3,5	60	217,5	80	2,71875	16	2	2	0	64	40	106,71875
46	3,5	60	221	80	2,7625	16	2	2	0	64	40	106,7625
47	3,5	60	224,5	80	2,80625	16	2	2	0	64	40	106,80625
48	3,5	60	228	80	2,85	16	2	2	0	64	40	106,85
49	3,5	60	231,5	80	2,89375	16	2	2	0	64	40	106,89375
50	3,5	60	235	80	2,9375	16	2	2	0	64	40	106,9375
51	3,5	60	238,5	80	2,98125	16	2	2	0	64	40	106,98125
52	3,5	60	242	80	3,025	16	2	2	0	64	40	107,025
53	3,5	60	245,5	80	3,06875	16	2	2	0	64	40	107,06875
54	3,5	60	249	80	3,1125	16	2	2	0	64	40	107,1125
55	3,5	60	252,5	80	3,15625	16	2	2	0	64	40	107,15625
56	3,5	60	256	80	3,2	16	2	2	0	64	40	107,2
57	3,5	60	259,5	80	3,24375	16	2	2	0	64	40	107,24375
58	3,5	60	263	80	3,2875	16	2	2	0	64	40	107,2875
59	3,5	60	266,5	80	3,33125	16	2	2	0	64	40	107,33125
60	3,5	60	270	80	3,375	16	2	2	0	64	40	107,375
61	3,5	60	273,5	80	3,41875	16	2	2	0	64	40	107,41875
62	3,5	60	277	80	3,4625	16	2	2	0	64	40	107,4625
63	3,5	60	280,5	80	3,50625	16	2	2	0	64	40	107,50625
64	3,5	60	284	80	3,55	16	2	2	0	64	40	107,55
65	3,5	60	287,5	80	3,59375	16	2	2	0	64	40	107,59375
66	3,5	60	291	80	3,6375	16	2	2	0	64	40	107,6375
67	3,5	60	294,5	80	3,68125	16	2	2	0	64	40	107,68125
68	3,5	60	298	80	3,725	16	2	2	0	64	40	107,725
69	3,5	60	301,5	80	3,76875	16	2	2	0	64	40	107,76875
70	3,5	60	305	80	3,8125	16	2	2	0	64	40	107,8125
71	3,5	60	308,5	80	3,85625	16	2	2	0	64	40	107,85625
72	3,5	60	312	80	3,9	16	2	2	0	64	40	107,9
73	3,5	60	315,5	80	3,94375	16	2	2	0	64	40	107,94375
74	3,5	60	319	80	3,9875	16	2	2	0	64	40	107,9875
75	3,5	60	322,5	80	4,03125	16	2	2	0	64	40	108,03125
76	3,5	60	326	80	4,075	16	2	2	0	64	40	108,075
77	3,5	60	329,5	80	4,11875	16	2	2	0	64	40	108,11875
78	3,5	60	333	80	4,1625	16	2	2	0	64	40	108,1625
79	3,5	60	336,5	80	4,20625	16	2	2	0	64	40	108,20625
80	3,5	60	340	80	4,25	16	2	2	0	64	40	108,25
81	3,5	60	343,5	80	4,29375	16	2	2	0	64	40	108,29375
82	3,5	60	347	80	4,3375	16	2	2	0	64	40	108,3375
83	3,5	60	350,5	80	4,38125	16	2	2	0	64	40	108,38125
84	3,5	60	354	80	4,425	16	2	2	0	64	40	108,425
85	3,5	60	357,5	80	4,46875	16	2	2	0	64	40	108,46875
86	3,5	60	361	80	4,5125	16	2	2	0	64	40	108,5125
87	3,5	60	364,5	80	4,55625	16	2	2	0	64	40	108,55625
88	3,5	60	368	80	4,6	16	2	2	0	64	40	108,6
89	3,5	60	371,5	80	4,64375	16	2	2	0	64	40	108,64375
90	3,5	60	375	80	4,6875	16	2	2	0	64	40	108,6875
91	3,5	60	378,5	80	4,73125	16	2	2	0	64	40	108,73125
92	3,5	60	382	80	4,775	16	2	2	0	64	40	108,775
93	3,5	60	385,5	80	4,81875	16	2	2	0	64	40	108,81875
94	3,5	60	389	80	4,8625	16	2	2	0	64	40	108,8625
95	3,5	60	392,5	80	4,90625	16	2	2	0	64	40	108,90625
96	3,5	60	396	80	4,95	16	2	2	0	64	40	108,95
97	3,5	60	399,5	80	4,99375	16	2	2	0	64	40	108,99375
98	3,5	60	403	80	5,0375	16	2	2	0	64	40	109,0375
99	3,5	60	406,5	80	5,08125	16	2	2	0	64	40	109,08125
100	3,5	60	410	80	5,125	16	2	2	0	64	40	109,125
101	3,5	60	413,5	80	5,16875	16	2	2	0	64	40	109,16875
102	3,5	60	417	80	5,2125	16	2	2	0	64	40	109,2125
103	3,5	60	420,5	80	5,25625	16	2	2	0	64	40	109,25625
104	3,5	60	424	80	5,3	16	2	2	0	64	40	109,3
105	3,5	60	427,5	80	5,34375	16	2	2	0	64	40	109,34375
106	3,5	60	431	80	5,3875	16	2	2	0	64	40	109,3875
107	3,5	60	434,5	80	5,43125	16	2	2	0	64	40	109,43125
108	3,5	60	438	80	5,475	16	2	2	0	64	40	109,475
109	3,5	60	441,5	80	5,51875	16	2	2	0	64	40	109,51875
110	3,5	60	445	80	5,5625	16	2	2	0	64	40	109,5625

7,968806424 days

Superstructure Girders
in minutes
in hours

					39,625						960	480	1479,625
					0,660416667						16	8	24,66041667
4	3,5	60	74	80	0,925	1	10	10	60	80	40	120,925	
20	3,5	60	130	80	1,625	1	10	10	60	80	40	121,625	
22	3,5	60	137	80	1,7125	1	10	10	60	80	40	121,7125	
38	3,5	60	193	80	2,4125	1	10	10	60	80	40	122,4125	
40	3,5	60	200	80	2,5	1	10	10	60	80	40	122,5	
58	3,5	60	263	80	3,2875	1	10	10	60	80	40	123,2875	
60	3,5	60	270	80	3,375	1	10	10	60	80	40	123,375	
78	3,5	60	333	80	4,1625	1	10	10	60	80	40	124,1625	
80	3,5	60	340	80	4,25	1	10	10	60	80	40	124,25	
98	3,5	60	403	80	5,0375	1	10	10	60	80	40	125,0375	
100	3,5	60	410	80	5,125	1	10	10	60	80	40	125,125	
102	3,5	60	417	80	5,2125	1	10	10	60	80	40	125,2125	

1,027517361 days

Variant 2B - optimized - Standard Floors and Superstructure Girders Installation Speed

Number of modules takes into account parallelized installation on-site by parallel Transportation Loops (TLs)

Standard floors	Logistics from ground to operational floor						Positioning, adjusting, fixation on floor					GSSF rising	Total	
	Floor level	Height of building	Length of building	Logistics distance	Logistics speed (m/min)	Logistics (min)	Number of modules	Positioning (min)	Adjusting (min)	Fixation (min)	Installation (min)	GSSF rising (min)	Total (min)	
in minutes						313,5					3840	3840	7993,5	
	in hours					5,225					64	64	133,225	
5,551041667 days														
Segment 1	1	5	3,5	60	77,5	80	0,96875	10	2	2	0	40	40	80,96875
	2	6	3,5	60	81	80	1,0125	10	2	2	0	40	40	81,0125
	3	7	3,5	60	84,5	80	1,05625	10	2	2	0	40	40	81,05625
	4	8	3,5	60	88	80	1,1	10	2	2	0	40	40	81,1
	5	9	3,5	60	91,5	80	1,14375	10	2	2	0	40	40	81,14375
	6	10	3,5	60	95	80	1,1875	10	2	2	0	40	40	81,1875
	7	11	3,5	60	98,5	80	1,23125	10	2	2	0	40	40	81,23125
	8	12	3,5	60	102	80	1,275	10	2	2	0	40	40	81,275
	9	13	3,5	60	105,5	80	1,31875	10	2	2	0	40	40	81,31875
	10	14	3,5	60	109	80	1,3625	10	2	2	0	40	40	81,3625
	11	15	3,5	60	112,5	80	1,40625	10	2	2	0	40	40	81,40625
	12	16	3,5	60	116	80	1,45	10	2	2	0	40	40	81,45
	13	17	3,5	60	119,5	80	1,49375	10	2	2	0	40	40	81,49375
	14	18	3,5	60	123	80	1,5375	10	2	2	0	40	40	81,5375
	15	19	3,5	60	126,5	80	1,58125	10	2	2	0	40	40	81,58125
	16	20	3,5	60	130	80	1,625	10	2	2	0	40	40	81,625
Segment 2	21													
	22													
	23	23	3,5	60	140,5	80	1,75625	10	2	2	0	40	40	81,75625
	24	24	3,5	60	144	80	1,8	10	2	2	0	40	40	81,8
	25	25	3,5	60	147,5	80	1,84375	10	2	2	0	40	40	81,84375
	26	26	3,5	60	151	80	1,8875	10	2	2	0	40	40	81,8875
	27	27	3,5	60	154,5	80	1,93125	10	2	2	0	40	40	81,93125
	28	28	3,5	60	158	80	1,975	10	2	2	0	40	40	81,975
	29	29	3,5	60	161,5	80	2,01875	10	2	2	0	40	40	82,01875
	30	30	3,5	60	165	80	2,0625	10	2	2	0	40	40	82,0625
	31	31	3,5	60	168,5	80	2,10625	10	2	2	0	40	40	82,10625
	32	32	3,5	60	172	80	2,15	10	2	2	0	40	40	82,15
	33	33	3,5	60	175,5	80	2,19375	10	2	2	0	40	40	82,19375
	34	34	3,5	60	179	80	2,2375	10	2	2	0	40	40	82,2375
	35	35	3,5	60	182,5	80	2,28125	10	2	2	0	40	40	82,28125
	36	36	3,5	60	186	80	2,325	10	2	2	0	40	40	82,325
37	37	3,5	60	189,5	80	2,36875	10	2	2	0	40	40	82,36875	
38	38	3,5	60	193	80	2,4125	10	2	2	0	40	40	82,4125	
39														
Segment 3	40													
	41	41	3,5	60	203,5	80	2,54375	10	2	2	0	40	40	82,54375
	42	42	3,5	60	207	80	2,5875	10	2	2	0	40	40	82,5875
	43	43	3,5	60	210,5	80	2,63125	10	2	2	0	40	40	82,63125
	44	44	3,5	60	214	80	2,675	10	2	2	0	40	40	82,675
	45	45	3,5	60	217,5	80	2,71875	10	2	2	0	40	40	82,71875
	46	46	3,5	60	221	80	2,7625	10	2	2	0	40	40	82,7625
	47	47	3,5	60	224,5	80	2,80625	10	2	2	0	40	40	82,80625
	48	48	3,5	60	228	80	2,85	10	2	2	0	40	40	82,85
	49	49	3,5	60	231,5	80	2,89375	10	2	2	0	40	40	82,89375
	50	50	3,5	60	235	80	2,9375	10	2	2	0	40	40	82,9375
	51	51	3,5	60	238,5	80	2,98125	10	2	2	0	40	40	82,98125
	52	52	3,5	60	242	80	3,025	10	2	2	0	40	40	83,025
	53	53	3,5	60	245,5	80	3,06875	10	2	2	0	40	40	83,06875
	54	54	3,5	60	249	80	3,1125	10	2	2	0	40	40	83,1125
	55	55	3,5	60	252,5	80	3,15625	10	2	2	0	40	40	83,15625
56	56	3,5	60	256	80	3,2	10	2	2	0	40	40	83,2	
57														
Segment 4	58													
	59	59	3,5	60	266,5	80	3,33125	10	2	2	0	40	40	83,33125
	60	60	3,5	60	270	80	3,375	10	2	2	0	40	40	83,375
	61	61	3,5	60	273,5	80	3,41875	10	2	2	0	40	40	83,41875
	62	62	3,5	60	277	80	3,4625	10	2	2	0	40	40	83,4625
	63	63	3,5	60	280,5	80	3,50625	10	2	2	0	40	40	83,50625
	64	64	3,5	60	284	80	3,55	10	2	2	0	40	40	83,55
	65	65	3,5	60	287,5	80	3,59375	10	2	2	0	40	40	83,59375
	66	66	3,5	60	291	80	3,6375	10	2	2	0	40	40	83,6375
	67	67	3,5	60	294,5	80	3,68125	10	2	2	0	40	40	83,68125
	68	68	3,5	60	298	80	3,725	10	2	2	0	40	40	83,725
	69	69	3,5	60	301,5	80	3,76875	10	2	2	0	40	40	83,76875
	70	70	3,5	60	305	80	3,8125	10	2	2	0	40	40	83,8125
	71	71	3,5	60	308,5	80	3,85625	10	2	2	0	40	40	83,85625
	72	72	3,5	60	312	80	3,9	10	2	2	0	40	40	83,9
	73	73	3,5	60	315,5	80	3,94375	10	2	2	0	40	40	83,94375
74	74	3,5	60	319	80	3,9875	10	2	2	0	40	40	83,9875	
75														
Segment 4	76													
	77	77	3,5	60	329,5	80	4,11875	10	2	2	0	40	40	84,11875
	78	78	3,5	60	333	80	4,1625	10	2	2	0	40	40	84,1625
	79	79	3,5	60	336,5	80	4,20625	10	2	2	0	40	40	84,20625
	80	80	3,5	60	340	80	4,25	10	2	2	0	40	40	84,25
	81	81	3,5	60	343,5	80	4,29375	10	2	2	0	40	40	84,29375
	82	82	3,5	60	347	80	4,3375	10	2	2	0	40	40	84,3375
	83	83	3,5	60	350,5	80	4,38125	10	2	2	0	40	40	84,38125
	84	84	3,5	60	354	80	4,425	10	2	2	0	40	40	84,425
	85	85	3,5	60	357,5	80	4,46875	10	2	2	0	40	40	84,46875
	86	86	3,5	60	361	80	4,5125	10	2	2	0	40	40	84,5125
	87	87	3,5	60	364,5	80	4,55625	10	2	2	0	40	40	84,55625
	88	88	3,5	60	368	80	4,6	10	2	2	0	40	40	84,6
	89	89	3,5	60	371,5	80	4,64375	10	2	2	0	40	40	84,64375
	90	90	3,5	60	375	80	4,6875	10	2	2	0	40	40	84,6875
	91	91	3,5	60	378,5	80	4,73125	10	2	2	0	40	40	84,73125
92	92	3,5	60	382	80	4,775	10	2	2	0	40	40	84,775	
93														
Segment 5	94													
	95	95	3,5	60	392,5	80	4,90625	10	2	2	0	40	40	84,90625
	96	96	3,5	60	396	80	4,95	10	2	2	0	40	40	84,95
	97	97	3,5	60	399,5	80	4,99375	10	2	2	0	40	40	84,99375
	98	98	3,5	60	403	80	5,0375	10	2	2	0	40	40	85,0375
	99	99	3,5	60	406,5	80	5,08125	10	2	2	0	40	40	85,08125
	100	100	3,5	60	410	80	5,125	10	2	2	0	40	40	85,125
	101	101	3,5	60	413,5	80	5,16875	10	2	2	0	40	40	85,16875
	102	102	3,5	60	417	80	5,2125	10	2	2	0	40	40	85,2125
	103	103	3,5	60	420,5	80	5,25625	10	2	2	0	40	40	85,25625
	104	104	3,5	60	424	80	5,3	10	2	2	0	40	40	85,3
	105	105	3,5	60	427,5	80	5,34375	10	2	2	0	40	40	85,34375
	106	106	3,5	60	431	80	5,3875	10	2	2	0	40	40	85,3875
	107	107	3,5	60	434,5	80	5,43125	10	2	2	0	40	40	85,43125
	108	108	3,5	60	438	80	5,475	10	2	2	0	40	40	85,475
	109	109	3,5	60	441,5	80	5,51875	10	2	2	0	40	40	85,51875
110	110	3,5	60	445	80	5,5625	10	2	2	0				

Superstructure Girders

in minutes
in hours

					39,23125					1840	480	2359,23125
					0,653854167					30,66666667	8	39,32052083
4	3,5	60	74	80	0,925	2	10	10	60	160	40	200,925
21	3,5	60	133,5	80	1,66875	2	10	10	60	160	40	201,66875
22	3,5	60	137	80	1,7125	2	10	10	60	160	40	201,7125
39	3,5	60	196,5	80	2,45625	2	10	10	60	160	40	202,45625
40	3,5	60	200	80	2,5	2	10	10	60	160	40	202,5
57	3,5	60	259,5	80	3,24375	2	10	10	60	160	40	203,24375
58	3,5	60	263	80	3,2875	2	10	10	60	160	40	203,2875
75	3,5	60	322,5	80	4,03125	2	10	10	60	160	40	204,03125
76	3,5	60	326	80	4,075	2	10	10	60	160	40	204,075
93	3,5	60	385,5	80	4,81875	2	10	10	60	160	40	204,81875
94	3,5	60	389	80	4,8625	2	10	10	60	160	40	204,8625
112	3,5	60	452	80	5,65	1	10	10	60	80	40	125,65

1,638355035 days

Construction Speed Comparison Table (Approach 4: Variain 1A, Variant 1B, Variant 1B, Variant 2A, Variant 2B, Variant 2B optimized)

Variant 1A	Days
Construction of 2 Superstructure	14,000
Girder levels	14,000
Setup of system	9,696
Standard floors	1,123
Superstructure Girders	7,000
Disassembly of system	
Total	45,819

Variant 1B	Days
Construction of 1 Superstructure	7,000
Girder level	10,000
Setup of system	9,455
Standard floors	1,194
Superstructure girders	5,000
Disassembly of system	
Total	32,649

Variant 2A	Days
Construction of 2 Superstructure	14,000
Girder level	14,000
Setup of system	7,615
Standard floors	0,970
Superstructure girders	2,000
Disassembly of system	
Total	38,586

Variant 2B	Days
Construction of 1 Superstructure	7,000
Girder Level	10,000
Setup of system	7,969
Standard floors	1,028
Superstructure girders	2,000
Disassembly of system	
Total	27,996

Variant 2B - optimized	Days
Construction of 1 Superstructure	7,000
Girder Level	10,000
Setup of system	5,551
Standard floors	1,638
Superstructure girders	2,000
Disassembly of system	
Total	26,189

6.1.13 Life-cycle and Building Integrated Manufacturing (Approach 6)

The analysis of Approach 5 and the evolution scheme in the former chapter showed that the integration of the target system, and thus the con-/and deconstruction within the building's design, structure and function generates multiple advantages:

- Transportation Loops (TLs) and Girder and Standard Floor Sky Factories (GSSFs) do not have to be assembled and disassembled as additional structures, which saves, time and cost.
- The crabs can be stored in dedicated basement floors and activated on demand for rearrangement of the building or deconstruction
- The cost of automated/robotic con-/deconstruction technology can be fully integrated into the building and operational costs (including the costs assumed for renovation and end of life).
- The integrated con-/deconstruction technology would not only reduce cost but also enhance the value of the building through:
 - The possibility of rapidly adapting a building during its life cycle
 - Prolonging the economic use phase of the building

For a detailed visualization of Approach 6, see *A0 plan "Approach to real-time and building-integrated automated Construction"*.

Approach 6 improves the concept of Approach 5 further in terms of:

Crabs becoming part of the building technology: Approach 6 improves the concept of Approach 5 further, considering point number 4 mentioned above, in particular. Each section of the high-rise building is assigned its own transportation loop, allowing the vertical segments (or groups of two segments as shown in the visualised approach 6) of the building to be built in parallel. For the visualized 144 floors high building thus four segment groups can be built of which each can be constructed on-site in parallel. The automated construction of a high-rise building could thus be turned from a sequential floor-by-floor manufacturing process into a parallelized into a process where the assembly of multiple segments or segment groups is done in parallel. Combined with Approach 5 this would mean that both the assembly of whole vertical segments as well as the assembly of units to floors within those segments could be parallelized. A building with 144 floors as visualized could thus roughly speaking can be produced within the time necessary to produce a 36 floors high building with the method presented in approach 5. The other way around this would mean that within the 26 day period set for Approach 5 buildings that are 4-5 times higher than the building assumed in Approach 5 (given the building is divided into 4-5 vertical segments or segment groups) can be built. This would result in the ability to assemble large high rise buildings with 400-500 floors within less than a month. Construction speed would thus be increased not only ten times but forty times, representing a major PME.

A further advantage of the subdivision of a building into vertical segments (and thus multiple vertically organized TLs) would result in the ability to exchanged or renewed complete vertical segments or individual groups of floors without affecting normal operation of the other building segments or the exchange of another segment.

The novel method presented in Approach 5 could serve as an early development state that could be furthered using the same technology and without major new technological developments towards the method suggested in Approach 6.

Modularity and Height: In contrast to approach 5, the transportation loops are not only a subsystem of the superstructure but become part of the superstructure itself. This also allows modularization of the superstructure and for the possibility of planning much higher buildings compared to those possible under Approach 5. If the building is planned to be higher, additional transportation loops (equal to a new superstructure layer) can be added.

“Aesthetics” of Con-/Deconstruction Technology: As stated earlier, Goldsmith and Kahn, through SOM, realized a multitude of buildings based on making a superstructure an aesthetic and clearly visible architectural element (**Grube et al., 1973; Murray, 1990; Grube & Krehl von Mühlendahl, 1974; Curtin et al., 1983**). Besides the superstructure/substructure approach, Goldsmith and Kahn followed the idea of making the static system and the force transmission from top to bottom an aesthetic and clearly visible architectural element. The result was a series of high-rise buildings which showed the increase of static forces acting on the buildings in a sequence from top to bottom by:

1. Increasing dimensions of structural elements (John Hancock Building, Chicago)
2. Reduction of window sizes (One Magnificent Mile, Chicago)
3. Increasing the building volume and number of tubes (Sears Tower, Chicago)

The idea of (visible) multiple/bundled tubes was introduced by Adler and Sullivan in 1891 (**Grube et al., 1973**), stating a possibility of creating extremely high buildings (for that time). With the Sears Tower and the John Hancock Building, SOM advanced that idea by relying on the newest research in material sciences and structural engineering. Furthermore, as is usual at IIT Chicago, student research projects supervised by Kahn and Goldsmith contributed to the advancement of high-rise and high-rise tube structures (e.g. Bock’s work on diagonally braced and irregularly shaped buildings; depicted for example in **Ali, 2001**). As an advance of the approach of Goldsmith and Kahn, who made the state-of-the-art engineering technology visible with their buildings. A novel generation of high-rise buildings integrating manufacturing technology as proposed by Approaches 5 and 6 could clearly show the use of the novel cutting edge technology: automated/robotic con- and deconstruction technology. Approach 6 gives the possibility of showing the interplay of superstructures, structural forces, functional/organisational structures of the building and of the novel technology becoming an integral part of the building. Following this concept, Approach 6 reduces the amount of superstructures from top to bottom and at the same time visualizes its function as transportation loops.

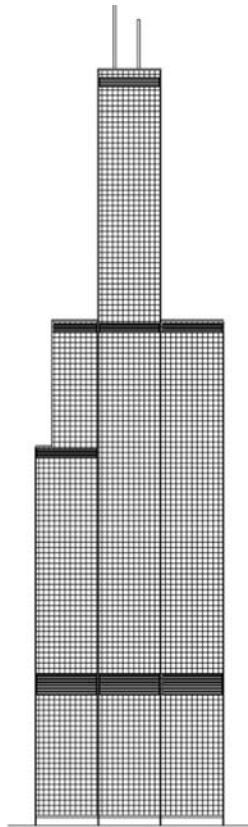

Sears Tower

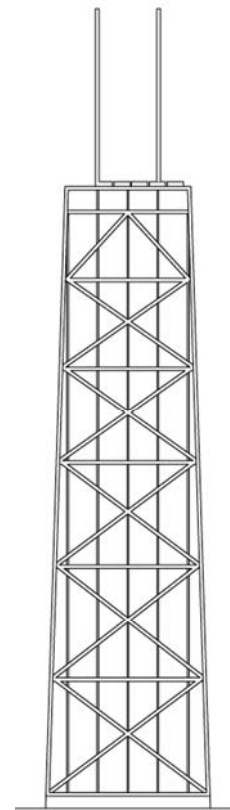

John Hancock Building

Figure 6-10: idea of (visible) multiple/bundled tubes (Sears Tower, John Hancock Building)

Approach 6 necessitates a complete change of structure of industry: The integration of building manufacturing/construction technology into the building would shift the focus more from the actual construction process (which would more or less proceed automatically) to the engineering process. This could be especially interesting for economic surroundings (Japan, Europe) where the availability of skilled construction workers is declining. Furthermore, the role of engineers and architects as integrators would be strengthened. **“Architectural Integration of Automation Technology”** or **“Automation Engineering in Construction”** could be built up as novel highly interdisciplinary planning professions linking development, design, structural engineering aspects, building technology and con-/deconstruction aspects. Countries like Japan and Germany, which are traditionally strong in Mechatronics and the engineering and delivering of specialized complex machine technology, would profit from a strong technological orientation of the construction sector in multiple ways and could strengthen demand for their key technologies even within the countries themselves.

6.1.14 Comparison of various approaches for automated and non-automated construction by value analysis (scoring-model)

A value analysis is used in early innovation or development phases when individual parameters, criteria or changes in weight or type of criteria cannot yet be expressed clearly in numbers or monetary value. Value analysis (scoring-model) was used by the author to support decision making within the R&D-projects LISA and GEWOS. The value analysis allows a set of criteria to be set up (target system), those criteria are assigned different importance (weighting system) and then finally various options are scored. Both set-up of weighting system and scoring are subjective and depended on individual goals of the entity performing it. Although a value analysis is thus more of a decision support method than a method that can generate an objective result, it can be used to analyze the behavior of strategies or approaches in various scenarios and to identify interdependencies between criteria and their weighting.

The value analysis conducted shows that a change of the weighting of criteria (e.g. due to a change in strategy and thinking or due to further growth of the importance of ecological issues in the future) can considerably influence the advantageousness of strategies in relation to each other. Furthermore the set up and analyzed criteria, and the weighting system, can create the basis for cost benefit analysis in later development phases. A value analysis was conducted which considered seven different site strategies ranging from conventional construction to the before suggested Approach 6. The systems were evaluated according to a set of criteria (target system). The criteria were linked to a system weighting them. The value analysis showed that a change of the weighting of criteria or sets of criteria, for example on the basis of changed economic situations, changed economic goals or changed values or priorities, or within a society changed the advantageousness of the systems to each other. This allows the evaluation of the systems in various assumed and future scenarios by the value analysis.

Strategies subject to evaluation:

- Strategy 1: Conventional
- Strategy 2: Systemized (e.g. Uptown/Peri)
- Strategy 3: Automated (e. g. SMART, ABCS)
- Strategy 4: Approach 5, Variant 1
- Strategy 5: Approach 5, Variant 2
- Strategy 6: Approach 5, Variant 2B, optimized
- Strategy 7: Approach 6

Criteria (target system) subject to the weighting system were chosen to represent the whole life cycle from R&D and developer issues to deconstruction phase. Via the weighting system and the evaluation, various criteria and thus various viewpoints (developer viewpoint, contractor viewpoint, and client viewpoint) can be emphasized.

Table 6-3: Weighting Criteria Value Analysis (Scoring-Model)

R&D (processes, skills, machine technology)	1	low R&D spending
	2	low investment in equipment
	3	low investment into ROD standards
	4	low investment into component/unit connectors
	5	low rate of adaptation of processes and organization
Development (developer issues)	1	Clear definability of cost
	2	clear definability of quality
	3	clear definability of construction period and time
	4	clear marketability
Planning	1	planning complexity
	2	design freedom
	3	use of existing building typologies/standards
	4	necessity of integration of phases and players
	5	necessity of complex planning tools
Construction Planning and Simulation	1	planning complexity
	2	necessity of complex simulation tools
	3	time necessary for planning and simulation
On-site System Set-up	1	complexity of on-site system set-up
	2	necessity of tests and certifications
	3	time necessary for system set-up
Building Realization	1	high construction speed
	2	high work productivity
	3	control of quality
	4	resource productivity
	5	transparency of cost and time
	6	working conditions/ safety/ health

Facility Use Phase	1	fast availability
	2	low downtime due to quality issues etc.
	3	flexibility & adaptability
	4	low downtime due to adaptation
	5	adaptability and resource productivity
Deconstruction	1	high speed of deconstruction
	2	high rate of recycling
	3	low disturbance of surroundings (noise, dust, etc.)
	4	working conditions/ safety/ health

Firstly, all criteria identified in Table 6-3 were evaluated for each of the seven strategies on a scale between 1 (low performance) and 8 (high performance). Then, for each of the following three scenarios, the weighting system was adapted:

Scenario 1: “Balanced”

- The weighting of the criteria as balanced without emphasizing the importance of a criteria or set of criteria. Scenario 1 represents the current situation in Europe.
- Result: Nearly all systems end up with a score of about 4.5. Due to the low efforts necessary in R&D (for details on R&D spending in construction see also **2.1**), the planning phase and construction planning and simulation, the conventional and systemized construction strategies are similarly advantageous as other approaches. Due to the efforts necessary in R&D, planning and construction planning, simulation, and the (compared to the approaches suggested in this chapter) relatively low productivity benefits, conventional automated construction (SMART, ABCS) shows the lowest score.

Scenario 2: “Focus on Development and Construction Speed”

- Scenario 2 represents a developer’s view. In scenario 2, costs for development of automated technology as well as engineering costs are neglected and the focus is solely on profitability for the developer and on the enhancement of construction speed.
- Result: The approaches discussed in this thesis and especially the approaches suggested in this chapter end up with slightly higher scores than the more conventional approaches. Of course it has to be considered that the cost for R&D, planning and construction planning in reality cannot be completely neglected and will also be partly handed over to the developer. However, possible state funding programs supporting the development and implementation of the novel technology and, for example, the rising costs for skilled labor could have considerably mitigated this effect.

		Assessment										Result (according to weighting)															
		Approach 1		Approach 2		Approach 3		Approach 4		Approach 5		Approach 6		Approach 7		Approach 3		Approach 4		Approach 5		Approach 6		Approach 7			
		Conventional		E.g. Urban/river		E.g. Smart		E.g. Smart		E.g. Smart		E.g. Smart		E.g. Smart		E.g. Smart		E.g. Smart		E.g. Smart		E.g. Smart		E.g. Smart			
Target	Level 1	Level 1	Level 2	Level 1	Level 2	Level 1	Level 2	Level 1	Level 2	Level 1	Level 2	Level 1	Level 2	Level 1	Level 2	Level 1	Level 2	Level 1	Level 2	Level 1	Level 2	Level 1	Level 2	Level 1	Level 2		
	Weighting	100%	100%	100%	100%	100%	100%	100%	100%	100%	100%	100%	100%	100%	100%	100%	100%	100%	100%	100%	100%	100%	100%	100%	100%		
RED	1. Low risk parking	3	2,50%	4	3	3	3	3	3	3	3	3	3	3	3	3	3	3	3	3	3	3	3	3	3		
	2. Low risk parking	3	2,50%	4	3	3	3	3	3	3	3	3	3	3	3	3	3	3	3	3	3	3	3	3	3		
	3. Low treatment into conventional connection	3	2,50%	4	3	3	3	3	3	3	3	3	3	3	3	3	3	3	3	3	3	3	3	3	3	3	
	4. Low treatment into conventional connection	3	2,50%	4	3	3	3	3	3	3	3	3	3	3	3	3	3	3	3	3	3	3	3	3	3	3	3
	5. Low treatment into conventional connection	3	2,50%	4	3	3	3	3	3	3	3	3	3	3	3	3	3	3	3	3	3	3	3	3	3	3	3
Development	1. Sustainability of land	2	3,33%	6	3,33%	6	3,33%	6	3,33%	6	3,33%	6	3,33%	6	3,33%	6	3,33%	6	3,33%	6	3,33%	6	3,33%	6	3,33%	6	
	2. Sustainability of land	2	3,33%	6	3,33%	6	3,33%	6	3,33%	6	3,33%	6	3,33%	6	3,33%	6	3,33%	6	3,33%	6	3,33%	6	3,33%	6	3,33%	6	
	3. Sustainability of land	2	3,33%	6	3,33%	6	3,33%	6	3,33%	6	3,33%	6	3,33%	6	3,33%	6	3,33%	6	3,33%	6	3,33%	6	3,33%	6	3,33%	6	
	4. Sustainability of land	2	3,33%	6	3,33%	6	3,33%	6	3,33%	6	3,33%	6	3,33%	6	3,33%	6	3,33%	6	3,33%	6	3,33%	6	3,33%	6	3,33%	6	
Planning	1. Service connectivity	3	4,17%	4	3	3	3	3	3	3	3	3	3	3	3	3	3	3	3	3	3	3	3	3	3	3	
	2. Service connectivity	3	4,17%	4	3	3	3	3	3	3	3	3	3	3	3	3	3	3	3	3	3	3	3	3	3	3	
	3. Service connectivity	3	4,17%	4	3	3	3	3	3	3	3	3	3	3	3	3	3	3	3	3	3	3	3	3	3	3	
	4. Service connectivity	3	4,17%	4	3	3	3	3	3	3	3	3	3	3	3	3	3	3	3	3	3	3	3	3	3	3	
	5. Service connectivity	3	4,17%	4	3	3	3	3	3	3	3	3	3	3	3	3	3	3	3	3	3	3	3	3	3	3	
Construction	1. High level of construction	3	3,33%	3	3	3	3	3	3	3	3	3	3	3	3	3	3	3	3	3	3	3	3	3	3	3	
	2. High level of construction	3	3,33%	3	3	3	3	3	3	3	3	3	3	3	3	3	3	3	3	3	3	3	3	3	3	3	
	3. High level of construction	3	3,33%	3	3	3	3	3	3	3	3	3	3	3	3	3	3	3	3	3	3	3	3	3	3	3	
	4. High level of construction	3	3,33%	3	3	3	3	3	3	3	3	3	3	3	3	3	3	3	3	3	3	3	3	3	3	3	
	5. High level of construction	3	3,33%	3	3	3	3	3	3	3	3	3	3	3	3	3	3	3	3	3	3	3	3	3	3	3	

Result: 4,5 4,275 4,625 4,75 4,5 4,5
 Ranking: 4 4 3 2 1 4

Value Analysis
Scenario 2: "Focus on Development and Construction Speed"

		Target System							Assessment							Result (according to Weighting)										
Level	Level 1	Level 2	Level 3	Level 4	Level 5	Level 6	Level 7	Level 8	Level 9	Level 10	Level 11	Level 12	Level 13	Level 14	Level 15	Level 16	Level 17	Level 18	Level 19	Level 20	Level 21	Level 22	Level 23	Level 24	Level 25	
Target	RED	1. New infrastructure	100%	100%	100%	100%	100%	100%	100%	100%	100%	100%	100%	100%	100%	100%	100%	100%	100%	100%	100%	100%	100%	100%	100%	100%
		2. New infrastructure	100%	100%	100%	100%	100%	100%	100%	100%	100%	100%	100%	100%	100%	100%	100%	100%	100%	100%	100%	100%	100%	100%	100%	100%
		3. New infrastructure	100%	100%	100%	100%	100%	100%	100%	100%	100%	100%	100%	100%	100%	100%	100%	100%	100%	100%	100%	100%	100%	100%	100%	100%
		4. New infrastructure	100%	100%	100%	100%	100%	100%	100%	100%	100%	100%	100%	100%	100%	100%	100%	100%	100%	100%	100%	100%	100%	100%	100%	100%
Development	1. Speed of construction	1. Speed of construction	2.00%	2.00%	2.00%	2.00%	2.00%	2.00%	2.00%	2.00%	2.00%	2.00%	2.00%	2.00%	2.00%	2.00%	2.00%	2.00%	2.00%	2.00%	2.00%	2.00%	2.00%	2.00%	2.00%	2.00%
		2. Speed of construction	2.00%	2.00%	2.00%	2.00%	2.00%	2.00%	2.00%	2.00%	2.00%	2.00%	2.00%	2.00%	2.00%	2.00%	2.00%	2.00%	2.00%	2.00%	2.00%	2.00%	2.00%	2.00%	2.00%	2.00%
		3. Speed of construction	2.00%	2.00%	2.00%	2.00%	2.00%	2.00%	2.00%	2.00%	2.00%	2.00%	2.00%	2.00%	2.00%	2.00%	2.00%	2.00%	2.00%	2.00%	2.00%	2.00%	2.00%	2.00%	2.00%	2.00%
		4. Speed of construction	2.00%	2.00%	2.00%	2.00%	2.00%	2.00%	2.00%	2.00%	2.00%	2.00%	2.00%	2.00%	2.00%	2.00%	2.00%	2.00%	2.00%	2.00%	2.00%	2.00%	2.00%	2.00%	2.00%	2.00%
Planning	1. Feasibility of land	1. Feasibility of land	1.00%	1.00%	1.00%	1.00%	1.00%	1.00%	1.00%	1.00%	1.00%	1.00%	1.00%	1.00%	1.00%	1.00%	1.00%	1.00%	1.00%	1.00%	1.00%	1.00%	1.00%	1.00%	1.00%	1.00%
		2. Feasibility of land	1.00%	1.00%	1.00%	1.00%	1.00%	1.00%	1.00%	1.00%	1.00%	1.00%	1.00%	1.00%	1.00%	1.00%	1.00%	1.00%	1.00%	1.00%	1.00%	1.00%	1.00%	1.00%	1.00%	1.00%
		3. Feasibility of land	1.00%	1.00%	1.00%	1.00%	1.00%	1.00%	1.00%	1.00%	1.00%	1.00%	1.00%	1.00%	1.00%	1.00%	1.00%	1.00%	1.00%	1.00%	1.00%	1.00%	1.00%	1.00%	1.00%	1.00%
		4. Feasibility of land	1.00%	1.00%	1.00%	1.00%	1.00%	1.00%	1.00%	1.00%	1.00%	1.00%	1.00%	1.00%	1.00%	1.00%	1.00%	1.00%	1.00%	1.00%	1.00%	1.00%	1.00%	1.00%	1.00%	1.00%
Construction	1. High rate of reviewing	1. High rate of reviewing	3.00%	3.00%	3.00%	3.00%	3.00%	3.00%	3.00%	3.00%	3.00%	3.00%	3.00%	3.00%	3.00%	3.00%	3.00%	3.00%	3.00%	3.00%	3.00%	3.00%	3.00%	3.00%	3.00%	3.00%
		2. High rate of reviewing	3.00%	3.00%	3.00%	3.00%	3.00%	3.00%	3.00%	3.00%	3.00%	3.00%	3.00%	3.00%	3.00%	3.00%	3.00%	3.00%	3.00%	3.00%	3.00%	3.00%	3.00%	3.00%	3.00%	3.00%
		3. High rate of reviewing	3.00%	3.00%	3.00%	3.00%	3.00%	3.00%	3.00%	3.00%	3.00%	3.00%	3.00%	3.00%	3.00%	3.00%	3.00%	3.00%	3.00%	3.00%	3.00%	3.00%	3.00%	3.00%	3.00%	3.00%
		4. High rate of reviewing	3.00%	3.00%	3.00%	3.00%	3.00%	3.00%	3.00%	3.00%	3.00%	3.00%	3.00%	3.00%	3.00%	3.00%	3.00%	3.00%	3.00%	3.00%	3.00%	3.00%	3.00%	3.00%	3.00%	3.00%

Result: 3,025 3,44 4,8 5,69 5,845 5,93
Ranking: 7 6 5 4 3 2 1

Scenario 3: “Growing Importance of Use and End of Life Phase”

- Scenario 3 is similar to scenario 2 but with an additional focus on the use phase and deconstruction phase (for example due to the growing importance of the reduction of resource consumption). In scenario 2, cost for development of automated technology as well as engineering costs are neglected
- Result: Strategies 6 and 7, which integrate the possibility of changing the building by integrated building manufacturing technology (and also of deconstructing the building) achieve by far the highest results.

Both the weighting and evaluation conducted above are exemplary and represent abstract use cases/scenarios. The aim of the value analysis was not to evaluate the systems on the basis of a real business case, but to show that the overall score (and thus efficiency) of strategies changes significantly with the view (developer, contractor, client), goals and possible economic or ecological trends. The analysis also shows that high investment in R&D, planning and construction planning and simulation pays off the more use phase and deconstruction phases are emphasized. A tendency towards building with better life cycle performance and the worldwide pressure to reduce resource consumption, could make scenario 2 (in mid-term) and 3 (in long-term) a reality, which would then make the investment in integrated building manufacturing technology and the associated changes feasible. The analysis also shows that the current approach of automated construction sites (strategy 3) on the basis of the set of criteria is not yet an efficient approach. Advancement of this strategy and more consequent application of automation technology (reduction of construction time to one-tenth, adding of reconfiguration and deconstruction capability, etc.) as proposed in this chapter, could make the novel technology efficient.

6.1.15 Generation of novel business opportunities by automated construction: space structures, marine structures, arctic structures, sub-marine structures, desert structures

Automation and robotic technology in construction in general (as analyzed in earlier chapters) and especially the approaches suggested in this chapter would give various industries the possibility of constructing value creating facilities in areas in which conventional crafts-based construction is difficult or impossible. Although there is no reason – as outlined above – to only apply automation and robot technology in so called 3-D-projects (Dull, Dirty and Dangerous, 3-D), it has considerable advantages in this field. The construction of large structures in space, on the ocean, in the arctic area, in deep sea and in deserts is a challenge or is impossible for conventional crafts based construction (e.g. space or deep sea). However, automation and robot technology could accomplish construction tasks in those environments and overcome the associated challenges or burdens. Large and repetitive structures could be built up fast and efficiently, and without interruption to which human work usually is subject to in harsh and unforeseeable environments.

- **Space Structures:** The automation of construction technology is a key competency for being able to construct larger structures efficiently in space. Therefore, Japanese major construction companies such as Shimizu Corporation - which have also been forerunners in automation and robotics in construction for decades – conducting research on space projects, from which on the one hand mankind would profit, and which on the other hand would necessitate their construction robot technology. In the 1990s, Shimizu’s space research division had up to twenty people and developed plans for space hotels and moon colonies. Today, the division is smaller but still developing, with serious research efforts, visionary projects such as the “Lunar Ring” (**Shimizu, 2012-1**), a ring of solar panels around the moon which could convert solar light into electricity and sends it via microwaves to earth. Shimizu studies the general concept, the microwave transmission technology and the construction robot system that would build the ring by using resources that are available on the moon as a basis.
- **Super Large Structures:** With rising world population and the on-going growth of large cities worldwide, the need for compact and vertically organized living space will grow. Examples of super tall structures are the Millennium Tower (Foster), The Pyramid (Shimizu) and X-Seed 400 (Takenaka). All three projects were intended to be built on artificial land in the Tokyo bay in order to create novel living space in the already super-dense Tokyo area. Although the projects have not yet been realized, the realization of such projects in the future in light of a growing world population is a question of time – and of (automated) construction technology.
- **Marine Structures:** The mining of resources shifts more and more to the sea area. Plans also intend that large drilling platforms on the sea not only host the people there but also their families, as well as hotels and leisure facilities and thus become cities on the sea. Automated construction technology can build, maintain, re-arrange and deconstruct such structures. As a large part of the earth’s surface is covered by water

and considering the rising world population and the rising demand for larger housing space per person, also the construction of habitat on sea area might be necessary in the future.

- **Arctic Structures:** The planning and deployment of arctic research stations is always a challenge for architects and builders. Today, the pressure to build in the arctic is increased by increasing necessity to mine resources in the arctic area. Automated construction technology can build, maintain, re-arrange and deconstruct such structures.
- **Sub-Marine Structures:** Worldwide, increasing resource consumption necessitates the advancement of mining of resources to deep sea areas. In the future, automated and robotic systems will be needed which are able to install deep sea mining systems in sea depths where work conducted by humans is difficult or impossible. Automated construction technology can build, maintain, re-arrange and deconstruct such structures.
- **Desert Structures:** Up to 40% of the world's land area is so called dry land areas. Additionally, due to global warming, desertification is increasing. Large structures that are able to generate or host water artificially in the desert would give the possibility of inhabiting and cultivating desert areas (e.g. Shimizu's Desert Aqua Net Plan; **Shimizu, 2012-2**).

The possibility of constructing and deploying architectural structures efficiently in those environments would create novel business opportunities for developers, constructors and architects, as well as for the industries for which those buildings would be constructed. R&D in the above mentioned fields could be seen an innovation field complementary to R&D in automation and robotics in construction. In the future it is likely that both fields will grow and develop in close relation to each other. The major Japanese construction firm Shimizu which has been developing and using automated construction technology for more than 30 years (STCRs as well as Automated/Robotic On-site Factories such as SMART, SMART light, Tower SMART and Hybrid SMART) employs a research division which is developing visions, concepts and plans for large scale construction in space, desert and on the seas. These are highly complex projects – and it is likely that with rising world population and resource consumption, the challenges for construction increase, are complementary to, and in some cases necessitate advanced automated construction technology. Japanese high tech construction industries (especially the LSP industry) also profits from an increase of complexity in construction.

Advanced construction technology could further create competitive advantages, as it reduces the possibility of business fields being taken over or processes and technologies being imitated by competitors from other countries (e.g. companies from low wage countries). Both in the automotive and aircraft industry, for example, the continuous enhancement of the product complexity and the manufacturing complexity is a powerful means to ban imitation, for example by companies from emerging economies. Companies such as BMW or Audi often openly reveal new concepts and technologies, as they are of the opinion, that the state of technology they have developed (integrated in the product as well as manufacturing technology) cannot be developed instantly, but has to be developed

over decades. However, non-capital-intensive and labor-intensive work (for further information, see 2.1) – as is the case in conventional construction in general- can be instantly imitated, and basically by any competitor. The low barrier for imitation by competitors also contributed (surely not solely but at least to a certain part) to the decline of the German construction industry (bankruptcy of Philip Holzmann AG, Russian takeover of Strabag, Spanish takeover of Hochtief, increasing share of foreign contractors). With the above mention technologies and strategies, however, it would be possible – as has been done by automotive industry and aircraft industry in Germany – to effectively use, create or extend the advantages of a high-tech location.

6.2 Synchronization of Organization, Building Structure and Manufacturing Technology by Robot Oriented Design

ROD is a central concept for enabling integrated automated construction sites and all those sites use, knowingly or unknowingly, ROD elements. It is concerned with the co-adaptation of construction products and automated or robotic technology, so that the use of such technology becomes applicable, simpler or more efficient. The concept of ROD was first introduced in 1988 in Japan by Bock (1988) and served later as the basis for automated construction and other robot-based construction systems sites around the world. It was developed for improving the construction sector and adjusting conventional construction processes and component design to the needs of the novel tools but its principles can be applied in various industries. In this chapter the concept of ROD is described in its present form and how it is interpreted and used today. ROD can be seen as an augmentation of the concept of DfX. DfX strategies are aimed at influencing design relevant parameters in order to support production, assembly maintenance, disassembly, recycling and many other aspects related to the products life cycle. The author of this thesis has during his work on R&D projects started to classify DfX strategies into four DfX categories: DfX related to production, DfX related to product function, DfX related to product end-of-life issues, and DfX related to business models.

In this thesis, ROD is seen as an augmentation or extension of conventional DfX strategies aiming more consequently at the efficient use of automation and robot technology in all four categories (*Table 6-4*). Additionally, in contrast to DfX, ROD explicitly emphasizes co-adaptation, meaning that besides the design/re-design of the product, the re-design of the automation and robot systems themselves are important means. Besides this category oriented view based on DfX categories, this thesis presents a complexity oriented view, a value chain oriented view and an architectonic scale related view. The complexity oriented view shows that ROD is able to reduce complexity within 5 complexity dimensions (kinematic/mechatronic complexity; sensor, process measuring and control complexity; organizational complexity; end-effector complexity; informational/computational complexity). The value chain oriented view considers that each step a (construction) product passes in the value chain gives the chance to pre-structure for the efficient use of automation and robotics in the next step. The scale oriented view provides a tool to consider ROD on component, building and master plan scale.

6.2.1 From Design for X (DfX) to Robot Oriented Design (ROD)

The design of any artefact (including architectural products) and its subsystems can be used to influence, support or even control all downstream life cycle phases, such as production phase, use phase and end of life phase. Furthermore, artefacts can intentionally be designed to support operation management and business models. Four categories of DfX strategies can be identified.

Table 6-4: Relation of Design for X (DfX) and Robot Oriented Design (ROD)

Design for X (DfX)	Robot Oriented Design (ROD)	
Production:		
Design for Production	Design that enables or supports automated or robotic production processes	
Design for Manufacture		
Design for Assembly		
Design for Failure Free Assembly (Poka Yoke)		
Design for Logistics		
Function:		
Design for Use/Function	Design that enables or supports enhanced performance of product or environments by embedded microsystem technology, mechatronics or robotics	
Design for Organizational Ergonomics		
End of Life:		
Design for Demanufacture	Design that enables or supports efficient automation and robot based demanufacture processes	
Design for Disassembly		
Design for Refurbishment		
Design for Remanufacturing		
Design for Recycling		
Business Model:		
Design for Malfunction	System design that enables the creation of business models that are compliant on automation and robot based production/function/end of life	
Design for Maintenance		
Design for Service		
Design for Open Service		
Human based	←—————→	Robot based

Design for Production (DfP): This category can be split into various sub-categories. A manufacturing process is the planned organization of labor, tools, machines and components. Design for Manufacturing (DfM) refers more to the overall production process, Design for Production (DfP) to the processing of raw materials or low complexity components (on-site or off-site) and Design for Assembly refers more to assembly processes of components or modules with higher complexity (on-site or off-site). The importance of distinguishing between manufacturing, production and assembly is explained

in detail in ElMaraghy & Wiendahl (2009). Logistics can also be seen on various levels, and a certain design (or modular design) can support logistics on a supplier-integrator level or on a factory level.

General speaking, the DfP category refers to strategies which are aimed at adjusting design and production parameters to each other so that the product can be efficiently produced and delivered to the customer. DfP means that products in the product development and planning phase are already structured and shaped in a way that later supports its production in a factory and on the production line. This might imply, for example, a modular structuring of a product so that modules can be produced in parallel processes or ordered separately and in parallel by suppliers before they are mounted on a platform or put together in a final stage. Further production issues that already have to be considered in the design stage are the product's or modules' sizes, the type of production (flow production, shop floor production), individual production processes, throughput times, logistics, supply chain design and degree of automation.

DfP mainly focuses on the design of the product, yet, it can also imply recommendation and planning of changes in the factory and production system. Through quickening innovation cycles, production facilities have to be used several times and for several product generations. Although production facilities can be rearranged and upgraded, it is often easier and more effective to adjust the product. However, product and production system have to be seen rather as an entity than as separate elements (Bock et al., 2010). Production systems such as the TPS, which form a very strong integration of production systems, products and human beings involved in the processes with a strong focus on human factors can be called socio-technical systems – here, product, production system and human beings form an entity. Concerning DfP strategies, Toyota has developed a unique set of methods to avoid defective or nonconforming products. It modifies both the product and the production/assembly system in order to achieve an efficient manufacturing. “Poka Yoke” (No-Failure Design; Toyota, 2011), addresses this issues in the design stage, “Jidoka “ and “Andon” aim at the manufacturing process and try to encounter failures that could not have been avoided through No-Failure Design. No-Failure Design has been introduced by Toyota step-by-step since the 1960s, transforming its design method and being today one of its most important design principles. No-Failure Design means that all modules, components and parts of the product have to be designed and structured in a way that erroneous joining and assembly later in the production process is impossible. This is a very radical approach, but as the TPS is based on the principle of avoiding stock as well as on continuous movement of all participating entities, every interruption of the production process through production errors has to be avoided (Ohno, 1988) . If, despite No-Failure Design, an error occurs, “Jidoka “ and “Andon” aim at correcting errors at point of occurrence. “Jidoka” means that a defect item should never be sent to the next production step. “Andon” allows a worker to slow down the production line in several steps in case of a production error and in parallel other workers come to help him to handle the situation jointly.

Design for Function (DfF): The Design for Function category emphasizes design strategies which aim at optimizing functional aspects of artifacts. Most artifacts are used to perform tasks and achieve goals or in the context of activities (those might be more work or more pleasure oriented) and can thus be seen in a broader sense as “tools”. One can improve the physical aspects allowing the efficient use of an artifact (ergonomics), the cognitive aspects of using an artifact (cognitive ergonomics), the (graphical) user interface (usability) or the larger process in which a product is embedded (organizational ergonomics). Similarly, living environments can be seen as “tools” which help us, or enable us, to perform activities of daily living within them. However, real research on improving living processes is rare. Interesting research on the improvement of processes related to kitchen environments has been done by Christine Frederick (**Frederick, 1913**), Margarete Schuette-Lihotzky (**Noever, 1992**) and Ottl Aicher (**Aicher, 2010**), all of whom aimed at creating more efficient (easier to use, faster to use) environments. Recently, the tendency towards an ageing society gives rise again to research in the efficiency of living environments (**Ambient Assisted Living, 2012**).

Completely novel assistive environments can now be created making use of “passive” architectonic elements; “active”, embedded micro systems technology; and robotic elements (**Murakami et al., 2008; Linner et al., 2011-a**). A first step in the direction of “assisted living” research in a real-world experimenting environment has been made by Linner et al. (**2011-b**) and Georgoulas et al., (**2012**). Similarly, artifacts can be optimized concerning the consumption of energy or other resources during use, for example, a big issue in today’s car and aircraft design is the minimizing of weight and fuel or energy consumption by optimizing designs. Airbus therefore uses new materials, such as carbon composites, aluminum, etched aluminum or steel pieces with cutouts that help to optimize force progression and reduce weight at the same time. In order to both optimize carbon composite as well as the use of structured aluminum pieces, an optimal design has to be found. Often functional aspects are related to tradeoffs or even restrictions through production processes. The new Airbus A 320neo is the first airbus that uses non-conventional two-dimensional winglets at the end of the wing to control airflow to so called sharklets. Sharklets are extensions of the wing with a three-dimensional twist.

To date, such forms have been difficult to produce – but the newest CAD/CAM equipment enables cost efficient production (**Airbus, 2012**). This is a good example of the fact that innovative functions and the newest design for function strategies are often enabled by the latest production technology or by complementary innovation in production technology (**Bock et al., 2012**). In relation to buildings, functionality can be modified on an individual elements level as well as on the building level.

Design for End-of-Life (DfEL): Strategies such as design for demanufacturing and re-manufacturing aim at designing products which enables them to be disassembled and for individual components or modules to be refreshed used again in new products or to be eventually recycled or at least disposed properly. Therefore the used artifact can go through various steps of the reverse manufacturing chain (demanufacture) and can be fed back into a certain step of the manufacturing process. The design of the product structure, modules

and interfaces has key functionality in enabling such processes. The following companies are currently pioneers in the field:

- Xerox, for example, allows old copiers to be remanufactured into newer models. Xerox has a remanufacturing plant in the UK. Equipment returned to Xerox can be remanufactured into new copiers reusing 70 to 90 % (concerning the weight) of components (**Xerox, 2012**).
- Boeing's latest military helicopter AH-64D Apache Longbow Block III Combat Helicopter (**Boeing, 2012**) is remanufactured on basis of major components as the chassis of older AH-64D models.
- The Japanese LSP company Sekisui Heim takes back the steel frames of its prefabricated buildings and remanufactures (or better: re-customizes them) them together with new parts and components into new buildings (**Linner, 2010**).
- Cars from the German car manufacturer, Audi, contain some parts that potentially have a technical life cycle 2-4 times that of the whole car. Audi would potentially be able to use them in brand new cars. However, strict safety regulations and reliability issues prevent Audi from doing this. Currently, therefore, Audi is using its well established used component circulation network only for feeding the spare part market (**Audi, 2011**).

All mentioned Design for End-of-Life strategies:

1. Are bound to a well-planned design of the modular structure
2. Are bound to a design of the interfaces and joints
3. Are bound to the design of the related assembly processes (welding, use of glue, use of bolts, etc.)
4. In case of remanufacturing strategies, subsequent models have to be designed in accordance with function standards and measurements of modules of older models

Similarly all kinds of artifacts and products can be optimized for disassembly (Design for Disassembly) and recycling (Design for Recycling). Design for Disassembly is often a prerequisite for efficient recycling of products. Recycling becomes efficient when in the design stage, the following design rules have been followed:

1. Reduce overall number of parts
2. Reduce overall number of components
3. Avoid Designs that necessitate the use of adhesives
4. Avoid inseparably connected parts
5. Design inseparably connected parts with compatible materials

To support the design of inseparably connected parts, engineering associations (e.g. the German Association of Engineers, VDI) or and standards institutions (e.g. DIN) provide tables and engineering standards showing levels of compatibility for inseparably connected parts. For example when two different plastics are used in one component and the molecules have a similar structure it is possible to meltdown and reprocess the whole

module. If plastics are not compatible, the module consisting of inseparably connected plastics cannot be reprocessed and thus must be disposed of.

Design for Business Model (DfBM): Artifacts have to be designed in full compliance with the business models of the economic environment which back them. Though often neglected by designers or architects, business models and the value streams related to those justify the existence of any product – including a built environment. By definition, a sustainable product must be economic, social and ecological (United Nations Indicators of Sustainable Development, 2012) at the same time. If a product to be designed is not economic it is also not able to support an enterprise's operational transformation process (**Slack et al., 2009**) and thus the organizational structures which design, produce and deliver it – with social consequences as well. In many industries (automotive, aircraft, furniture, and real-estate), companies or designers at a certain design stage have to involve marketing divisions as well as production engineering divisions or even make employees of this division a part of the design team to ensure that relevant parameters are implemented during the design phase. Designs are able to control the business model of artifacts. This comprises service oriented designs that support maintenance or upgrades, as well as designs which allow remanufacturing or recycling. Maintenance and upgrade operations can, for example, be led by modular designs and the allocation of the modules. The allocation depth of modules and sub-systems within complex products plays an important role in this context and Schmiieder & Thomas (**2005**) have developed tools for arranging them according to the specific need of modification over time.

Designs supporting maintenance and upgrading are often more costly to accomplish than designs not supporting over-time changes, as more resources have to be invested in development, materials and production. Artifacts with such features are often not sold as final products but handed over as services and operated by companies (Sundin, 2009), as this is the only way that allows companies to take products back directly and to make use of the inbuilt modularity and changeability.

A good example for Design for Business Model is also Apple's iPhone. Basically, the iPhone's hardware can be mass produced efficiently and only minor variations are available (storage capacity, color). However, customization and adaptation to a user is done on the electronic or informational level by adapting the Graphical User Interface (GUI) or by installing individual Applications (Apps). This software based variation or adaptation, in contrast to hard physical adaptation is relatively easy and cost efficient to achieve. The designers have built up a modular structure and the customers can only influence the software based modules, but not the hardware based modules – this simplifies internal organization and production and delivery processes. Furthermore, in addition to a careful and business model oriented modular design, the iPhones physical look-and-feel design is so reduced and universal that it fits potentially to any personal taste. So the design of the iPhone combines a universal appearance on the one hand with the ability of a high degree of adaptability (on the informational level), on the other hand. Apple also demonstrates that when it comes to customization today, services in a broader sense (as content services, communication services, music services, information services and Apps) have become

more important than the physical product, becoming more and more commoditized (Gilmore & Pine, 2000) and used as a service channel (Shimomura & Arai, 2009). Many business scientists (Chesbrough, 2010; Cusumano, 2010) indeed foresee an inevitable development towards services and the delivery of products as services which mean that future products have to be designed (or re-designed) to support new service based business models.

6.2.2 Designing within capabilities of the manufacturing system

Often tradeoffs have to be made between DfX strategies of different categories or even between DfX strategies with individual categories. For example Design for Disassembly might necessitate that that individual modules, components or parts of a product are demountable, which prevents the use of joining methods by glue or welding or the use of integral designs – all of which would speed up or make the production easier. Critical tradeoffs can also be caused by the implementation of DfX strategies, within the production category, for example. The aforementioned Design for Logistics strategy by Audi, which reduces the weight of any component to be assembled to less than 20 kg, requires larger components to be broken down into sub-modules that are delivered by internal or external suppliers. Thus, this practice at the same time increases logistics efforts and requires additional assembly operations on the final assembly line. However, enhancement of work ergonomics, worker health and worker motivation seem to equalize a reduction of production efficiency by this practice.

Once a house or building is seen as a product that is produced off-site or on-site by the use of rationalized, mechanized, automated and/or robotic production processes, DfX strategies, as well as the aforementioned tradeoffs, apply. For example, the production-line-based production of completed building modules equipped with all installations and appliances, and the subsequent delivery processes of the modules to the site by trucks, requires the modules to have a maximum length, width and height. Although middle columns can be skipped for the creation of large rooms, this has implications, and thus tradeoffs, for the room configurations and designs possible (and thus the Design for Function category). A similar tradeoff has to be made concerning the size of components for automated construction size. Large sized modules reduce the effort of assembly work on-site but require logistics and positioning systems that are able to carry heavy components with large dimensions.

The examples within this and the former sections show that Design for Function, Design for End of Life and Design for Business Models are of high importance but that the Design for Production category in most cases is at the center of the decisions to be made. This applies to the creation of all artifacts for which a more or less complex production system has been set up (mass production, large and low batch production, variant production and even for industrially customized production/MC). With the introduction of automation and robotics into any of the production types mentioned, the importance of the production process within general tradeoff decisions intensifies. Processes and technologies related to

automation and robotic based production require a certain amount of resources to be spent on its development, set-up and operation.

A product that is not designed within the capabilities of the production system does not utilize the value of the production system set up. Of course it is possible to design outside the capabilities of the given production system, but this might result in additional costs for the change of the production system, and thus in higher costs for both the producer and the customer (**Boning & Hardt, 2009**). However, automation and robotics based production systems today are no longer mass-production-like, fixed and unchangeable systems. For more than a decade, the importance of individual customer needs and faster innovation cycles have put pressure on the development of production systems with inbuilt flexibility (the ability to process a range of products within its capability, **ElMaraghy & Wiendahl, 2009**) or changeability over time (**Fujimoto, 1999**). Drivers for flexibility are novel sensor technologies, industrial vision systems, novel data processing algorithms, enhanced computing power and speed and advances in cognition (Cognitive Factory, **Zäh et al., 2009**). Drivers for changeability are tendencies towards modularity and interchangeability of industrial automation systems, and robotic equipment. The aforementioned tendencies allow for more flexibility, reduce the need to design within capabilities and reduce the necessity of redesigning components. Flexible and/or changeable manufacturing systems do not erase but reduce the need for tradeoffs to be made.

As outlined above, ROD can be seen as an augmentation of DfX strategies. Although a fixed border between DfX and ROD cannot be set, ROD aims more radically at the use of automation and robotics. ROD has been specifically developed for use in the context of construction and construction products (in this dissertation the built environment is seen as a product), but it can also be used for the design and development of a broad range of products or artifacts. ROD can be seen as an augmentation of DfX strategies in all four categories explained above: Production, Function, End-of-Life, and Business Model. In the following, the augmentation of DfX by ROD for each category will be explained:

ROD related to production aspects: ROD related to production aspects refers to design strategies that enable or support efficient automated or robotic production processes. A classic example of ROD in this category is the Sony Walkman. When introduced in 1979, the Sony Walkman (TPS-L2) was not only an innovative product concerning size and function, but also a product with an excellent price- performance ratio. The price for the Walkman was below €100 and comparable products were not only bigger, but also the cost was beyond €200 or 300. However, the comparably low price was an important parameter that at the end led to the big success of the Walkman. The low price – and thus the market introduction and realization of the Walkman – was enabled by an innovative production method. The Walkman was produced on highly automated production lines (**Hasegawa, 1999**) and under extensive use of the SCARA (Selective Compliance Arm for Robotic Assembly).

The SCARA is a Japanese invention that combines two revolutes and one prismatic joint so that all motion axes are parallel (see, **2.4**). This configuration and the thus enabled allocation

of the actuators is advantageous for the stiffness, repeatability and speed with which the robot can work. Due to its simplicity, the SCARA is also a comparably cheap robot system. The disadvantages of the SCARA are its small workspace and that assembly operations can be only performed by the robots restricted end-effector manipulation along the vertical z-axis. However, once the operations have been brought into its work space and have been designed to be assembled from above along the vertical z-axis, the SCARA becomes a powerful and cheap solution for production. Thus the design of the Sony Walkman was optimized for the assembly with the SCARA. All components, such as electronics and cartridge drives could be placed and fixed in the plastic case by performing operations along the z-axis. During the 80s many companies in Japan optimized their products designs for the assembly with the SCARA.

Today the SCARA-like kinematics are delivered by all major robot companies (e.g. Kuka, Yusukawa, Fanuc) and they are important in nearly all industries that produce rather small components or products. All automation and robot systems have their advantages and disadvantages. Just like the Walkman was for the SCARA, basically any product can be optimized for the manufacturing or assembly by a specific automation or robot system. Additionally, since the 1990s more and more robot systems have been capable of being customized (e.g. Festo), are available in many variations (e.g. Kuka's new Quantec Series robot for high payloads which is available in more than 40 variations) or are modular (e.g. Schunk) despite (nearly) no additional cost. It has therefore become more feasible to modify both the product and the automation or robot system and to co-adapt them for the generation of an efficient production system (see also **2.4**). Co-adaptation including the modification of the automation or robot system can be seen as a fundamental ROD strategy. If necessary, ROD could also cover, for example, the set-up or modification of a manual assembly process if this process would support the efficient use of automation or robotics in production steps before or after.

ROD related to functional aspects: ROD related to functional aspects refers to design that enables or supports enhanced performance of products or environments by embedded microsystem technology, mechatronics or robotics. For example, ROD can structure, organize and design built environments in a way that allows for a more efficient deployment of (mobile) service robots. When Joseph Engelberger introduced his hospital logistics robot – one of the first commercially available service robots – he delivered not only the robot but also a set of guidelines for structuring the environment. The problem for any service robot is that usually service environments – in contrast to factory environments – are rather unstructured environments. In factories work tasks, workspaces, assembly directions and many other parameters can be standardized, thus simplifying the possible operation capability of the robot system. In most service environments, work tasks, movement of people as well as the configuration of the environment are not fixed as standard, requiring the robot to be equipped with a range of sophisticated sensor systems and a multitude of actuators to be able to cover a wide range of possible work tasks. Engelberger's guidelines for designing the environment are an approach for structuring the environment for the robot. He gave recommendations for allocation and structure of the stations to which the robot logistically connected to, such as nursing stations, labs, elevators and pharmacies.

The robot was designed in compliance with measurement standards of medical storage systems as well as ergonomic aspects. Dedicated parking and charging areas would support a smooth operation in a busy hospital environment and a recommended connection with the elevator (including a design of the elevator that allows the robot to move in) would allow for a better utilization of the capacity of the robot as it then could work on multiple floors.

Another way of structuring the environment is the provision of digital 3-D models of the environment as basis for robot motion planning (e.g. via **Gazebo/ROS; ROS, 2012**). However, pre-modelled environments do not consider changes in the environment. Hasegawa suggests that in a robot town, mobile robots equipped with laser scanners could move around in the environment, producing a continuously updated 3-D model of the environment, and providing this model to other robot systems that would thus not have to be equipped with such sophisticated sensor systems (**Hasegawa, 2010**). Service Robots checking, cleaning or repainting the outside of high-rise buildings have also been successfully implemented by using ROD approaches.

Figure 6-11 shows examples of such service robots. All successfully implemented systems have been rail-guided. In contrast to other systems that could move freely or that would adhere to the facade by a vacuum suction cup, this approach simplifies the robot's motion system and motion planning systems significantly, thus reducing both initial costs and operational costs of the robot. Furthermore, rails ensure that the robot is safely fixed to the building. Two types of rail-guided robot systems can be distinguished: horizontally moving systems and vertically moving systems. Both types require that the architectural design integrates the rails, taking into account the specifications and workspaces of the robots. The rails themselves can be simple profiles which are nevertheless often used by architects for functional and aesthetic means.



Horizontal-type facade robot, office building, Japan



Vertical-type facade robot, office building, Japan



Vertical-type facade robot, office building, USA

Figure 6-11: ROD related to functional aspects. Efficient application of maintenance robots requires buildings to be designed taking into account the robot's specifications.

ROD related to end-of-life aspects: ROD related to End-of-Life aspects refers to designs that enable or support efficient automation and robot based demanufacture processes. It is a quite novel research field and standards and methods – especially related to the built environment – have yet to be defined. However, it is necessary as currently all major Japanese contractors are introducing systems for computer controlled and partly automated deconstruction (presented in detail in 5.3). Such systems allow for both fast deconstruction and high recycling rates, as the building is not demolished but systemically deconstructed. As those methods enable resources to be recovered, scientists speak in terms of such methods of “urban mining”. An interview with a R&D staff member of Kajima revealed that such systems have to be applied roughly 5-8 times before they become a profitable business (Kajima, 2011). However, both Kajima and Takenaka have encountered the problem of finding buildings to be deconstructed that fit the specifications of their systems without major modification of their technology.

- Kajima’s system requires the building to be constructed on the basis of a reinforced concrete beam and column based structure and that enough space in the basement is available which allows the computer controlled hydraulic presses to be installed and the cutout of the columns. Additionally, the building must have a certain height otherwise the installation of the system would not pay off.
- Takenaka’s System requires that the building has several internal staircases and supply cores that, after core removal, can be used for taking down the deconstructed material within the factory cover. Additionally, the structure of the building must ensure that the factory’s CS can be attached to the building at regular distances. The building must also have a certain height, otherwise the installation of the system would not pay off.

Both examples, on the one hand, show that the deconstruction technology itself has to become more flexible. On the other hand, certain standards or planning guidelines would be necessary to regulate how buildings and their sub-components have to be designed to allow for deconstruction by one of those systems. Such guidelines could, for example, imply that basement space has to be designed in a certain way (to fit Kajima like approaches) or that core removal can be applied to regularly placed staircases and supply cores (to fit Takenaka like approaches). In Europe, low-rise and high-rise office buildings have a long life cycle (often more than 60 years) and to think of the deconstruction from the beginning seems farfetched. However, in Asia, life cycle for such buildings is often set at below 30 years, and sometimes even lower. In fast changing cities in Asia, the consideration of such guidelines allowing the systematic deconstruction of a building are much more feasible.

ROD related to business model aspects: Not only production or service environments can be structured, so too can the economic surroundings of the robot. ROD related to business model aspects refers to a co-adaptation of a robot system and business models in tune with automation and robot based production function or end of life strategies. John Deere is one of the biggest manufacturers of farming equipment in the US. The company also has a robotics division concerned with equipping machines such as trucks and harvester-threshers with robotic technology (sensors, positioning systems, autonomous

driving, device to device communication, tele-operation capability). The related research field is called “precision farming”. John Deere therefore cooperates with institutions leading in robotics research as for example Carnegie Mellon University. John Deere has currently reached a point whereby multiple machines could cooperate and autonomously harvest, for example, a crop field and the upcoming research question is how many devices can be overseen by one operator. However, John Deere has seen the problem coming, that farmers themselves are not trained or capable of operating such high-tech equipment (or even systems of multiple machines). The company sees the solution in a step-by-step shift towards a service provision model. In the future, John Deere will not sell equipment any more, but rather square meters of cropped land (**Moorehead, 2010**). Using that model, John Deere could internally fully utilize the capacity of its farming robots by highly skilled and experienced company staff operating them. John Deere has realized that the shift towards more and more complex farming equipment – pushed by its own R&D divisions – would as a next step require it to advance from a product manufacturer to a service provider.

A well designed co-adaptation of robotic operation devices, products and business models has been done by Project Better Place (**Better Place, 2012**). As batteries of electrical cars are expensive, the company is working on setting up a battery infrastructure. The battery will not be owned by the car owner, but by Better Place, which charges the driver for the used energy. Better place will build up a battery infrastructure with fully automatic battery exchange stations as a core technology. Once a battery starts to run out of energy, the car will be directed to the next Better Place station, where the battery is automatically exchanged with a fully charged battery. The robot technology implemented in this exchange makes recharging faster and more convenient than conventional re-fueling, for example. New battery technology, robotic exchange stations and a new business model here form a well-designed entity.

Furthermore, initiatives such as SMErobot (**SMErobot, 2009**), a European initiative for strengthening the competitiveness of Small and Medium Sized Enterprises (SMEs) in manufacturing, and major robot manufacturers (as for example KUKA) seek new business models that would open up the robot market to smaller enterprises. Therefore KUKA is working on business models that would allow SMEs to lease or rent its expensive lightweight robot. The lightweight robot (**Kuka, 2012**) is a highly dexterous robot arm that could work in the direct operating range or cooperatively with human beings and would thus support SMEs in particular in producing individual or customized products. However, due to the advanced technology, the lightweight robot is comparably expensive and cost after the start of mass production in 2013 will still be more than €60,000 (**Kuka, 2011**). Too expensive for SMEs to own as a tool for production - however, leasing or renting the robot would substantially lower the risk for SMEs and would make the robot an interesting solution for them.

6.2.3 Dimensions of for and based through ROD

ROD is a strategy that aims at co-adaptation of both the construction products and automated/robotic manufacturing/assembly operations in order to enhance the efficiency of the total construction process. Especially in construction, the work pieces to be manipulated, transferred, or assembled are, compared to work pieces of other industries, rather large in size and heavy in weight. This means that links have to be extremely stiff and force resistant, and actuators need to be capable of manipulating heavy loads. This results, for example, in rather large and heavy (compared to robot systems known from automotive industry) robotic systems used for positioning and assembly of construction components (for further details, see technical analysis **5.2** and **5.3**).

Actuators are a particular challenge, as in order to be able to manipulate heavy payloads they are large and heavy - which again enhances the necessary pay load capability of the production system and also has a negative impact on repeatability. Furthermore, this results in the fact that the on-site construction factory itself which covers the site or building also has to be designed as a heavy system, which is capable of carrying those robotic subsystems and to resist forces and vibrations as a reason of the manipulation of components by them. Thus the design of work pieces (parts, components, modules, buildings) has to ensure that the complexity of the production process (both on and off site) is kept low. ROD can reduce following 5 areas of complexity:

- Kinematic/mechatronic complexity
- Sensor, process measuring and control complexity
- Organizational complexity
- End-effector complexity
- Informational/computational complexity
- Life-cycle related complexity

6.2.4 Reduction of kinematic/mechatronic complexity

Automated and robotic systems are mechanical configurations that are built up by a combination of links and joints (prismatic and revolute). Additional links and joints – depending on the configuration on the system – add a DOF to the system. Depending on the complexity of the assembly process, the system needs a certain number of DOFs to be able to perform this assembly process. At least 3 DOFs are necessary to locate an object in space (x, y, z- axis) and at least 3 DOFs are necessary to orientate an object (explained in detail in **2.4**) Often more DOFs are required as due to technical or geometrical restrictions not each DOF can be utilized at full capacity (redundancy). Generally speaking, each DOF requires additional actuators and additional links to be added to the system. Due to the heavy payloads required in construction, both actuators and links are expensive. Furthermore, each new DOF means that robot motion planning becomes more complex and that better algorithms, hardware or computing power is necessary to operate the system. The reduction of DOFs, and along with that the kinematic complexity, is thus

especially in automation and robotics in construction essential for creating efficient production systems. As with a high amount of DOFs, the cost and operational complexity could easily exceed any payable budget (of course this depends also on the business model) the reduction of the kinematic complexity is a key parameter for enabling the introduction of automation and robotics in the construction industry.

The SCARA based production of the Sony Walkman is a good example for the reduction of kinematic complexity achieved by redesign of work piece and the design of a suitable conveyor system (explained previously in this chapter, see **6.2.1** and **6.2.2**). The DOFs are reduced to three, and complex positioning and especially orientation activities are avoided.

Within most automated construction sites, the columns can be placed by a motion along the vertical z-axis and compliant joints ensure that the placed component snaps into place (e.g. System SMART). This practice requires several DOFs for positioning the component in space (x, y, z- axis) but almost erases the necessity for complex orientation (yaw, pitch, and roll) of the component. In terms of robot composition (**see 2.4**), the reduction of the kinematic orientation complexity is one of the most efficient ways to reduce the complexity of the robot as a simple wrist (part of the robot that performs the orientation) allows for simpler robot bases/arms (part of the robot that carries the wrist) and lower payload capacity.

6.2.5 Reduction of sensor, process measuring and control complexity

As explained in **2.4**, automated and robotic systems are specified, apart from by links, joints and actuators, by the integration of feedback of proprioceptive (internal) sensor systems, exteroceptive (external) sensor systems. However, sophisticated and complex sensor systems (as e.g. high precision vision systems) are still costly and error prone, and each sensor system added to the system adds to the computational complexity. A design or re-design of components can help to reduce the necessity to integrate additional or complex sensor and control systems. Especially compliant joints as in the example of SMART and RCACS can reduce the sensor, process measuring and control complexity as they simplify the positioning and adjusting process which is an inherent feature of every assembly or construction operation.

In the case of SMART, a conically shaped extension positioned on the top of the column on which a new column segment will be positioned and a convex bottom of the column segment form a connection system that allows for some tolerance when a column segment is positioned by the robotic overhead crane. Convex and concave parts of the connector are designed as an integral part of the column segments prefabricated off-site. Although SMART uses laser scanners to generate an overall picture of the advance of the construction process, this column assembly process requires no dedicated sensor system for high accuracy position control.

In case of RCACS, ROD allows for a simplified positioning of beam segments by a robotic crane. Beam segments are finally positioned by motions along the z-axis. Four metal (two

on each side) plates, attached as an integral part of the column-beam T-shaped segments positioned, first ensure guidance and a smooth slide into position of the later placed beam segments. The two metal plates on each side form a conically shaped entry which guides a slightly swaying or roughly positioned beam segment into its final position. The metal plates both guides the work piece into position and forms the connecting element between the beam segments fixed by a bolting robot in a subsequent work step. This beam assembly process requires no dedicated sensor system for high accuracy position control.

For rough positioning of components within automated construction sites, integral transducers (step counters, encoders, etc.) attached to the actuators of the robotic crane or trolleys moving along the roof of the factories or cable transducers are sufficient to determine the actual state of the system and the position of the component to be installed, and adapt them in real time to the intended and pre-determined positioning activity. However, for precise alignment and adjustment- if not possible to simplify alignment/adjustment or erase the need for alignment/adjustment by compliant joints – additional sensor systems such as laser scanners, vision systems and ultrasonic sensor systems are necessary. If those systems are required, it is still a necessity to keep the system simple and reduce the amount of sensor systems necessary by ROD, if possible. Laser scanners are today for example available in a huge variety ranging from simple one-dimensional to more complex and expensive three-dimensional measuring systems. In environments with dynamic elements, such as, for example, human beings, the components to be positioned and adjusted should be calibrated by sensor systems from at least two, or better three or more directions, in order to avoid measuring interruptions. If further precision or high reliability and accuracy is required, it is recommended that the data of various different sensor systems (e.g. laser scanners and vision systems) are fused. Also, complex orientations necessary to position or adjust a component should be avoided, as this, besides kinematic/mechatronic complexity, would necessitate sensors that are able to determine a robot's and/or components' orientation in 3-D, using for example inclinometers, accelerometers and gyroscopes.

6.2.6 Reduction of organizational complexity

The design of components or the robot system or the optimized co-adaptation of both should be able to reduce the human labor, activities, motions or even whole work steps required to complete positioning and assembly tasks. This applies in construction for off-site processes as well as for on-site processes. Similarly, as DfX, for example, is able to reduce the number of parts (**presented previously in this chapter, see 6.2.1**) and thus the number of (manual) assembly steps, and the time and resources required, a design of a component can reduce assembly steps and resources (human workers, the number of robotic systems and other tools or resources) necessary to reduce organizational complexity related to automation and robotic applications. The fewer assembly steps and resources involved in any production or assembly process generally results in less effort for managing interfaces between resources and timely coordination. When speaking of

organizational complexity, the author refers to this interplay between work steps, resources, interfaces, management and timely coordination.



Figure 6-12: Reduction of organizational complexity. Left: A Korean facade installation robot requires three workers to be operated and does thus not fulfill the requirements to reduce organizational complexity (picture courtesy of Lee, see also **Lee, 2008**). Right: ABCS uses connectors in combination with a robotic overhead crane, reducing the number of workers to only one worker supervising many parallel activities at once, and the need for assisting workers guiding the component has been completely removed (graphical representation according to **Obayashi, 1993**)

During his work at TUM, the author (and the chair holder) were asked by a Korean Post Doc to analyze and evaluate a ceiling wall installation robot that the Post Doc had developed for SAMSUNG Construction (*Figure 6-12*, left). The documentation material provided (**Lee, 2008**) revealed that the whole process (only basic positioning, not including final assembly) took more than ten minutes (depending on operational sequence 15-18 minutes, see **Lee, 2008**) and that three workers were required to assist with the installation of one facade element during the whole process (one controlling the machine/robot, two to take care of the element). Nevertheless, the workers are relieved ergonomically, the process, especially for the two assistants caring for the element during the process is dangerous, as they have to work near the unsecured abyss at extreme heights. In comparison, conventional installation by cranes from the outside requires a similar amount of time, similar amount of workers to be involved and is similarly dangerous.

Thus, the described system and the suggested procedures did not simplify the interplay between work steps, resources, interfaces, management and timely coordination. Considering the fact that a novel and expensive device has to be developed and introduced on-site, it is strongly recommended that organisational complexity (including safety issues)

are reduced in order to free resources necessary to develop and introduce the new system. To improve the system, the author, together with the chair holder suggested that the size of the installed facade elements should be increased. This would enhance the productivity of the system, as with the given amount of three workers, at least a greater square-meter facade unit per time unit (per hour or day) could be achieved.

As a further step, a working group with which the author of this thesis was involved suggested that compliant and self adjusting joints be developed which would allow for the amount of assisting workers to be reduced. The change of the size and weight of the facade elements would have resulted in a major redesign of the developed robot and the introduction of a compliant connector system would have necessitated close cooperation with the supplier of the facade elements. Samsung was not willing to invest in those changes and finally stopped the project. In contrast to the Korean System, Obayashi when using the Automated Building Construction System (ABCS) uses connectors in combination with a robotic overhead crane, thus reducing the amount of workers to only one worker supervising many parallel activities at once, and the need for assisting workers guiding the component was completely erased. The connector:

- Allows the facade element to be placed by the robotic overhead crane (simplifying the assembly process) by an operation only along the vertical z-axis.
- Allows for even the slightly swaying facade elements to be guided into place automatically, reducing the need for guidance by assistant workers, as in the Korean example, or dedicated sensor systems for high accuracy positioning.
- Ensures a the facade element is fixed automatically by a spring-lock, once it is in the correct position. The element is thus in the right position, and ready for final assembly and finishing.

Figure 6-12 (right) shows the connector system on the right side of the facade element. Each element has two of these connector systems – one on the right side of the element and one on the left. The elements are positioned within ABCS's self-climbing super-construction-factory by a robotic overhead crane. The two parts of each connector system are modules built into the prefabricated floor components and facade components.

6.2.7 Reduction of Gripper-/End Effector Complexity

ROD is able to reduce the complexity of the gripper's (also called end-effector) automated or robotic manipulators. The end-effector is the tool at the end of the cinematic chain which actually manipulates the object. End-effectors are available in huge variety and the same type of robot in general can be equipped with different end-effectors. The role and importance of end-effectors for automated/robotic manufacturing was explained in detail in **2.4** (general manufacturing industry) as well as in **3.1** (component and unit manufacturing in construction), **3.3** (shipbuilding, aircraft industry, automotive industry) and in particular in **5.2** and **5.3** (Automated/Robotic On-site Factories). Complex end-effectors in themselves can be seen as small robots. However complex end-effectors should be avoided:

1. A complex end-effector with many mechanical parts or systems to be actuated and controlled increases the difficulty in synchronizing it with the robot's motions.
2. A complex end-effector might influence the payload and or repeatability.
3. The end-effector is the part of the robot which continuously gets into touch with the work-piece or object to be manipulated. The more complex the end-effector is, the more difficult it is to maintain or guarantee its robustness mechanically, and in terms of control.
4. Kinematic complexity of the end-effector requires additional joints and actuation systems, resulting in higher costs. The mechanics of a gripper is often actuated by an air pressure system that is located next to the robot on the ground transferring the air pressure via cables to the wrist. On the one hand this makes the gripper lighter; on the other hand those systems consume high amounts of energy resulting in high operational cost.
5. Sensor, process measuring and control complexity of the end-effector should be minimized. Complex grasping activities require the presence of proprioceptive (internal) and exteroceptive (external) sensor systems as basis for the regulation of the end-effector's motions.
6. Organizational complexity related to the gripper can be reduced through avoiding or automating for example the change of a gripper system.

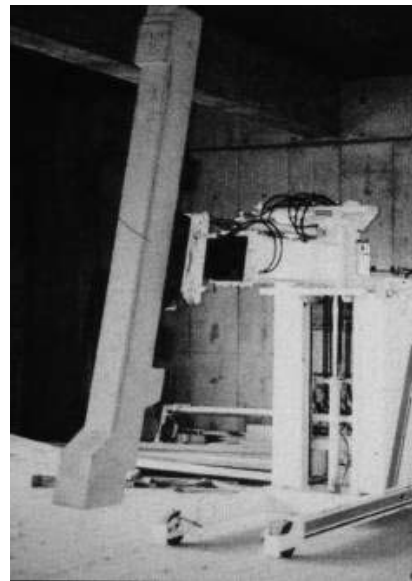
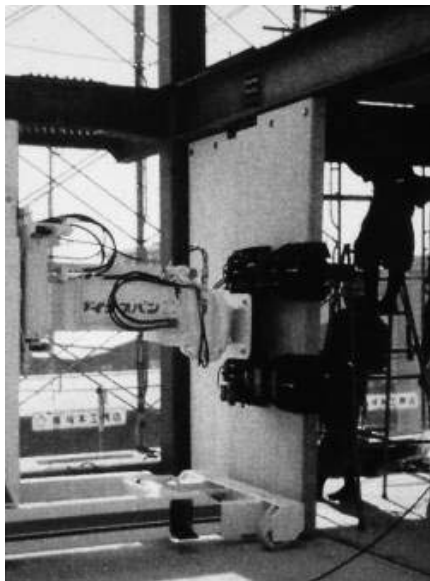

Figure 6-13: Reduction of gripper-/end-effector complexity. Left: A standard concrete element is enclosed by a heavy and powerful pincer-like gripper. Right: The gripper impales the concrete element, designed in accordance with ROD principles, resulting in gripper-/end-effector complexity.

A good example of end-effector complexity reduced by ROD can be seen by comparing two Kajima STCR end-effectors used to place concrete elements. Both robots are able to

pick up and position heavy concrete elements. The gripper in *Figure 6-13* (left) is heavy and complex. A standard concrete element is enclosed by a heavy and powerful pincer-like gripper. Furthermore, the end-effector protrudes on the right side of the concrete element and thus makes installation process in tight spaces difficult. The gripper in *Figure 6-13* (right) is less complex and represents an excellent example for applied ROD. Basically, it consists of a steel plate with two rods. This hook impales the concrete column via two complementary designed holes in the concrete column. The concrete column with those holes has been designed by Kaijima to simplify pickup process and gripper of the robot. The concrete column has been prefabricated off-site.

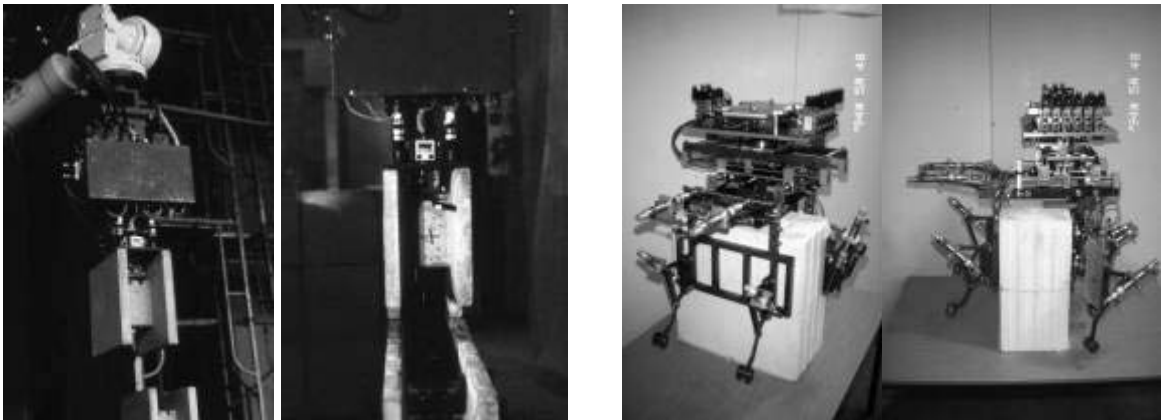

Figure 6-14: Reduction of gripper-/end-effector complexity. The SMAS gripper compared to the ROCCO gripper shows lower kinematic and sensor, process measuring and control complexity. Left: SMAS, a specially designed stone allows the gripper to impale the redesigned stone and screw it onto the stone below. Right: The handling of a gripper of a standard and non-redesigned stone results in higher complexity of the gripper system.

Another example of ROD reducing gripper complexity can be seen by comparing the gripper of the SMAS (Solid Material Assembly System, *Figure 6-14*, left) and one of the grippers developed within the research project ROCCO (Robot Construction System for Computer Integrated Construction, **Andres & Bock, 1994**, *Figure 6-14*, right). The SMAS gripper compared to the ROCCO gripper shows lower kinematic and sensor, process measuring and control complexity. A specially designed stone allows the gripper to impale the redesigned stone. The stone is 30cm x 30cm x 18cm in size and 20kg in weight. Along with the stone the gripper places a rack that screws together the stone to be positioned and the already fixed stone below it together (later on the interior of the produced wall shell will be filled up with concrete embedding the screws and resulting in a reinforced concrete wall). The screwing mechanism not only connects the stones but also helps to guide the stone into place vertically. To ensure accurate positioning along the lateral axis, the stone has overlapping edges guiding it during the positioning operation. The alignment process is only supported by a simple fiber optic sensor. The ROCCO gripper is much more complex, containing many mechanical parts, many joints and tactile sensors. It manipulates a

standard non-redesigned stone. In order to secure a safe grasp and accuracy when positioning, adjusting and fixing the stone, a complex robotic end-effector (gripper) with a multitude of mechanical parts and DOFS had to be developed.

6.2.8 Reduction of information/computational complexity

Information can be seen as common element of development, planning production and production. Based on the knowledge about a prospective customer, information is embedded in a product through design and production. Fujimoto (1999), famous for his research on the TPS, even goes one step further and claims that consumers consume not goods or services but information, “(...) what he or she consumes is essentially a bundle of information delivered through the car rather than the car as physical entity”. Similarly, Piller describes production as a process whereby physical materials are transformed through machinery, organization and information into products. From this information point of view, it is necessary to see all steps of the value creation process as a set of complementary subsystems, which jointly embed information and transform physical materials through information in order to create value. However, the amount of information (in the following referred to as information complexity) that flows within a production process is limited and controlled. Especially with increasing digitalization, and the aim of increasing the level of automated and robotic systems, information complexity is closely linked to computational complexity.

The relations between complexity and information (Traub & Werschulz, 1999) and computational complexity (Arora & Barak, 2009) are the subject of research. Calinescu (2002) defines the increase in complexity in a manufacturing system as an increase in “entropy” rising with factors in the production systems as variety, flexibility, interactions between entities and stations and uncertainty. With an increase in entropy, the information describing the system or a state of the system becomes more complex. In automation and robotics in construction this view on information complexity applies as well. Generally speaking, an increase of complexity in all formerly mentioned dimensions of complexity (kinematic/mechatronic; sensor, process measuring and control; organizational; end-effector) increases the amount of information and thus computational complexity necessary to

1. Describe the state of all deployed subsystems
2. Model the interfaces and interactions between all subsystems
3. Model all possibilities of a system (e.g. an increase in DOFs also means that the potential motions of individual links and joints rise)
4. Control all subsystems over time

Conventional construction sites are highly unstructured, flexible and uncertain environments that can hardly be described by a limited amount of information. Integrated automated construction sites, however, are an approach to structure environments, the process, interactions between human and machines, and information and material flows within it in

order to reduce computational complexity necessary to control the automated and robotic subsystems and their activities.

6.2.9 Reduction of complexity throughout life cycle

The synchronization of the design and structure of the building can balance the complexity of subsequent phases of the life cycle of a building (construction, maintenance, rearrangement and deconstruction). Some companies that applied automated construction sites synchronized the construction technology and the structure of the building, so that the steel frame of the construction factory after completion of the last floor on top of the building became the frame for the uppermost floors and thus part of the building (e.g. Obayashi, ABCS). The complexity of disassembling the site-factories subsystems was thus reduced considerably. Furthermore, as the analysis of automated deconstruction systems has shown, stable top-floor structures can be used as basis for the installation of automated gantry-type OMs (see **5.2.1** and **5.2.2**, for example **ABCS**, **Akatuki 21**, **Roof Push-Up** and **SMART**; **5.2.3**, for example, **T-Up**; and **5.3.1**, for example **TECOREP**). The synchronization of the building structure with the needs and dimensions of robot systems can reduce the complexity of the operation of rail-guided maintenance robots (see for example facade painting, maintenance and cleaning robots, analyzed in detail in **4.1.12** and **4.1.15**). From a conception point of view, an interesting approach for consequent synchronization of component structure, robotic construction technology and building design was developed within the research project funding line “ESPRIT” (EU Information Technologies Program). The concept proposed that the automated construction technology (lifting mechanisms, working platforms and robot system) become part of the building (*Figure 6-15*). This would take away the need to disassemble the construction technology and reduce on-site construction time, on-site work activities and logistics efforts. The cost for the construction technology could thus be partly to cost for anyhow necessary building components.

The previously discussed approach to real-time and building-integrated automated construction (see **6.1**, and in particular **6.1.13**) advances this approach and shows that on the basis of a common measurement system (e.g. BMU, for further explanation, see **6.1.9**) a complete integration of the construction technology into the building’s life cycle (construction, maintenance and rearrangement, deconstruction) could be achieved.

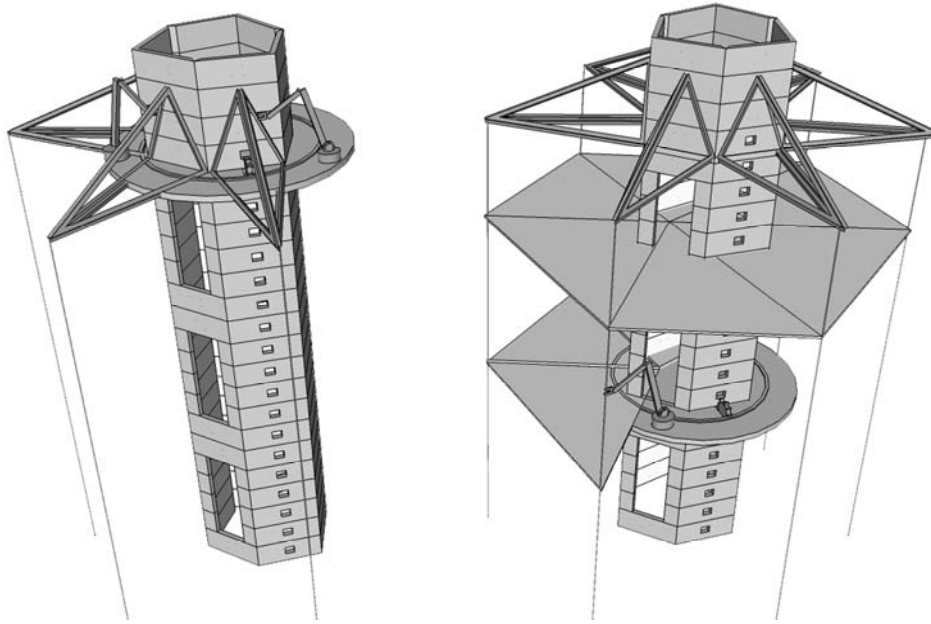

Figure 6-15: Approach for the integration of building structure, construction technology and building design. (Graphical representation according to Bock and Centre Nationale de Re-cherches et Sciences/First National Committee Robotique en BTP, Paris, 1989)

6.2.10 Complexity reduction along the value chain by ROD

Like in any other industry, the value and complexity of work pieces or products rises along the value chain in construction. In conventional construction, a multitude of low complexity single parts, components (and sometimes modules) are assembled directly on the construction site. Thus, the operational transformation of “inputs” into “outputs” is done directly on the construction site. This also means that the on-site process becomes complex as a multitude of logistics and assembly processes related to rather small and unprepared parts has to be coordinated, managed and controlled. In automation and robotics in construction, which sees the building to be created as a product, complexity is subsequently reduced along various steps in the value chain. In this thesis a distinction is made between pure production (usually an off-site process), prefabrication/pre-assembly (usually an off-site process) and on-site automation.

Pure Production:

- In pure production, simple parts with low complexity are usually produced in an off-site process in a factory. In prefabrication/preassembly, parts are processed or assembled into more complex components, modules or units.

Prefabrication/Preassembly:

- In component production, parts are processed into components: e.g. bricks to prefabricated brick walls (e.g. Rötz) or steel profiles and other parts to prefabricated steel frame wall elements (e.g. Sekisui House).
- Modules in this thesis are defined as complex building blocks consisting of parts and components, which both have lower complexity. Modules are building blocks that have for example installations (pipes, cables), windows or even appliances already integrated. A representative example for this category are the prefabricated and finished bath cells of Inax or more complex prefabricated walls with windows and installations already integrated.
- Units in this thesis are defined as highly complex building blocks consisting of parts, components and modules. Representative examples are the steel based units prefabricated by companies such as Kleusberg and Cadolto in Germany and Toyota, Sekisui Heim and Misawa in Japan. Those units represent a whole three-dimensional part of a building almost completely finished in the factory. In the case of Sekisui Heim, this allows for up to 80% of all work tasks to be done in the factory, and due to the high finishing degree, only minor works have to be done on site (20%).

On-site Automation/Robotics:

- In on-site automation and robotics, building blocks with different complexity (parts, components, modules, and units) are attached to the final building product using automated and robot technology supported construction techniques (assisted workers, STCRs, on site construction factory, integrated automated sites).
- Through prefabrication or pre-assembly, parts are processed to more complex components, modules or units. Those are then sent to the construction site. This means that compared to conventional construction, less and more complex items arrive at the site. Nevertheless low complexity parts might be used, for example, for finishing the building as this practice ensures that the logistics and assembly processes taking place on site are less complex and that the efforts needed for coordination management and control are reduced.

This complexity reduction applies also for all subsequent steps within the block prefabrication/pre-assembly. An LSP company like Sekisui Heim (**see 3.2 and in particular 3.2.1, 3.2.2, 3.2.3 and 3.2.4**) that breaks down a building into units being produced on the production line processes modules and components that come pre-assembled from suppliers or internal production/assembly units along with parts, reduces complexity of internal logistics, assembly processes and organization. The units Sekisui Heim produces are of high complexity (in most cases they even contain pre-installed appliances) and ensure that work activities on the final site are minimized. The units can be attached on-site to a weather proof building within one day and finishing work can be done within 4 weeks on-site.

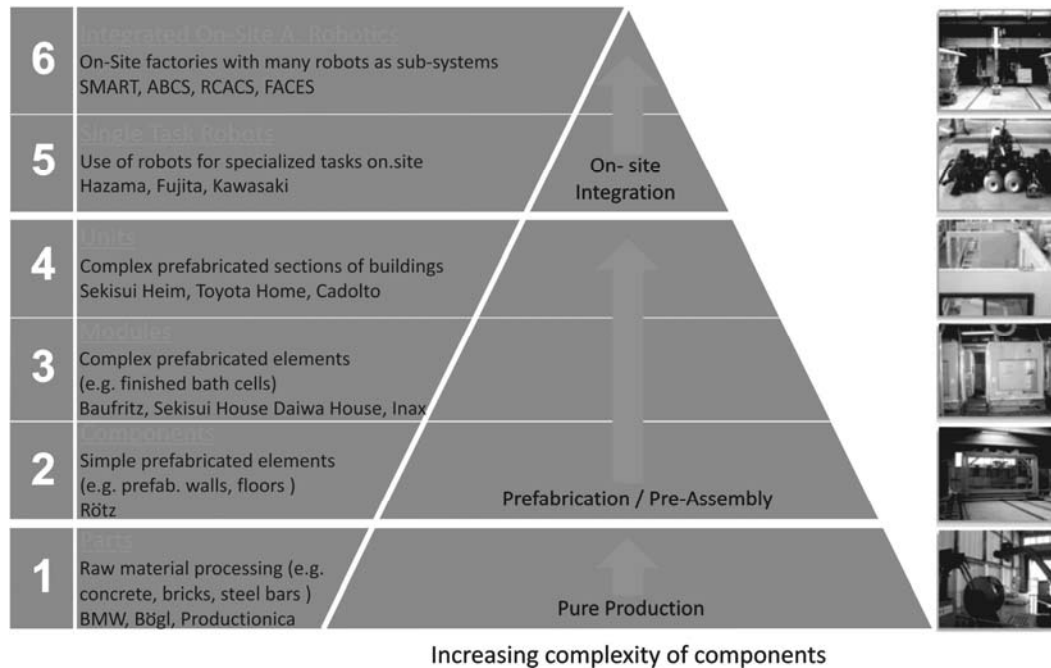

Figure 6-16: Complexity reduction along the value chain. In automation and robotics in construction, which sees the building to be created as a product, complexity is subsequently reduced along various steps in the value chain. We distinguish between pure production (usually an off-site process), prefabrication/pre-assembly (usually an off-site process) and on-site automation.

Although the units of Sekisui Heim are conventionally assembled on-site (as they are only produced for single family houses and small apartment or office buildings), they would be the perfect building element for automated sites, as they reduce the complexity of logistics and assembly operations. The technical analysis of automated/robotic on-site factories (see **5.2** and **5.3**) shows that, to date, most automated construction sites have not yet used units but rather highly complex prefabricated components and modules along with parts. Complex parts allow a reduction of complexity in all five dimensions (kinematic/mechatronic complexity, sensory, process measuring and control complexity, organizational complexity, end-effector complexity, informational/computational complexity) takes place because each step in the value chain in which an element is processed reduces the amount of components and activities to be processed by automated or robotic systems. Additionally, each step allows for components to be designed, redesigned, prepared or improved further according to ROD guidelines for being processed by automated and robotic systems. As each step reduces complexity, amount of work pieces, work tasks and management operations, it can be said that each step has the ability to support the generation of a more SE in the next step. As discussed before, SEs are a pre-requisite for the efficient application of automation and robotics in general.

Example 1: Complexity Reduction by use of parts and components during module assembly. A representative example for complexity reduction by use of parts and components during module assembly states the LSP of bath modules by INAX. The Japanese company INAX produces prefabricated cells with all installations (cables, pipes etc.), bath appliances and tiles and other finishing parts already integrated to fully finished bathrooms in the factory. The assembly takes place on a production line where a carrier unit (usually the base plate) is equipped with a mixture of components and more complex (prepared or pre-assembled) parts. As for any production line process, it is necessary that complex parts or at best components, either prepared in earlier production steps, or by suppliers, are delivered to the production line. The module assembly process of Inax and Toto, and the practice of thus integrating modules into unit assembly processes of Sekisui Heim and Toyota Home were analyzed and discussed in detail before in **3.2**, and in particular in **3.2.4** and *Figure 3-2*.

Example 2: Complexity reduction by use of components during unit assembly. Toyota prefabricates highly complex building blocks (Toyota calls them skeletons with infill) on the production line in the factory. On the production line, prepared parts and components are attached to a three-dimensional steel frame serving as a carrier component during LSP and later in the finished building as a load bearing steel skeleton. In the case of Toyota Home, up to 85% of all work necessary to construct a single family house is done in the factory (presented in detail in **3.2**). On the production line, a large amount of rather complex parts or components are installed. Additionally, highly complex exterior wall elements (finished and already equipped with window elements) are attached to the three-dimensional steel frame. The high complexity of the element reduces the amount and complexity of work tasks to a minimum and allows for positioning, adjusting and fixing of the whole exterior wall in one work step. One worker can complete the process by simply guiding the wall component to the steel frame by use of a manually guidable overhead handling device. The fixation of the wall element ensures that the module is already in the right position concerning two axes (vertical and horizontal axis), allowing the worker to be able to quickly adjust the component. Thus the high complexity of the component reduces kinematic complexity, sensor and process measuring complexity (no sensor systems needed), organizational complexity and end-effector complexity. If the exterior wall components are of lower complexity, a multitude of parts or lower complexity components are positioned, adjusted and fixed. This would involve a multitude of different gripper systems and also more complex work activities. Thus, at least organizational complexity and kinematic complexity would increase.

Example 3: Complexity reduction through use of modules during unit assembly. Sekisui Heim prefabricates highly complex building blocks (Sekisui Heim calls them units) on the production line in the factory (see also **3.2**, and in particular *Figure 3-2*). On the production line, prepared parts and components are attached to a three-dimensional steel frame serving as carrier component during LSP and later in the finished building as a load bearing steel skeleton. In the case of Toyota Home, up to 80% of all work necessary to construct a single family house is done in the factory. On the production line a high amount of rather complex parts, components and even modules are installed. Furthermore, a

completely finished bath module coming from a supplier (Inax or Toto) is JIT installed into one of the units passing by on the production line. A manually controlled overhead crane with a gripper device is able to lift and position the module into the unit passing by. In position in the unit the workers can simply adjust the whole unit, fix it and connect cables and pipes to the unit's installation system. The highly complex modules ensure that work activities on the production line are reduced to a minimum (organizational complexity). As only one element has to be positioned by a simple manual handling system, both kinematic complexity and sensor and process measuring complexity have been reduced. Tradeoffs to the mentioned reductions of assembly complexity are the rather complex gripper and the heavy structure of the handling system needed for positioning.

Example 4: Complexity reduction through use of units on-site. As both Sekisui Heim and Toyota Home produce highly complex units that are already equipped with appliances, installations and basic finishing, in the factory, work activities on the construction site are reduced to a minimum. The basic weatherproof positioning, adjusting and fixing of the modules on-site can then be done within one day. This is possible as the high complexity of the units created in the factory off-site reduces complexity on the construction site. Depending on the building's size only 10-15 finished building blocks have to be assembled on site by 4-5 workers. Both the amount of work tasks is reduced, and the remaining work tasks are simple. Positioning and adjusting are supported by conically shaped (compliant) positioning racks in each corner of a unit guiding the unit into place and also erasing the need for adjusting and fixing. The basic assembly process of the units thus becomes a simple repetition of lift down operations along the z-axis. Furthermore, as facades are completely finished in the factory, scaffolding on-site is not needed.

Example 5: Complexity reduction through use of components and modules on automated sites. Buildings consist of a multitude of parts – especially high-rise buildings, which contain more parts than any car or aircraft produced by the use of automation and robotics. If one delivered single unprepared low-complexity parts to a site – as is usual in conventional construction – it would be impossible to use automation and robotics. A huge number of different and rather complex positioning, adjusting and fixation operations would be required. This would result in the necessity of numerous different, highly flexible robots, high necessary operation speed due to the number of parts to be positioned and sophisticated sensor and control systems, as many small parts have to be aligned and adjusted. Additionally many different types of grippers/end-effectors would be necessary to cope with the huge number of positioning and fixation operations necessary. The low complexity of parts would create an unstructured environment, demanding high flexibility – it would be possible to deal with such complexity in a fixed off-site factory environment, but hardly in a climbing and temporary on-site factory. Complexity in the previously mentioned dimensions would be created and would result in a complex production system with an enormous cost. Thus, within automated construction sites, complexity of the production system has to be reduced by structuring the environment through the delivery of pre-assembled parts and complex building blocks (components, modules, units) to the site. The analysis (see 5.2 and 5.3) shows that all automated construction sites assemble the building's main structure and building envelope on-site in particular, through the use of

prefabricated complex building blocks that simplify positioning, adjusting and fixation operations and allow for fast finishing of the building by use of a reduced amount of parts.

One representative example for the use of components reducing the complexity of the robotic system on-site are those components processed by Kajima's AMURAD (presented in detail in 5.2.4). Kajima prefabricates reinforced concrete components with reinforcement connections to those elements below and above it and steel profile extensions for the connection of horizontal steel beams (*Figure 6-17, left*). Those extensions are not only the basis for the connection of the beams but also a ROD feature which allows the rail-guided robot (*Figure 6-17, right*) to easily pickup, carry and position the component. Another example for the reduction of kinematic, mechatronic and organizational complexity within automated construction sites through prefabricated building blocks is the use of facade modules within Obayashi's ABCS (presented in detail in 5.2.1). Those facade elements are large scale and are already integrated with installations, widows and exterior and interior finish materials. This reduces the amount and complexity of positioning, alignment and fixation operations to be done on-site. Furthermore, as the module is already integrated with finishes, manual rework and finishing operations are also reduced. The robotic overhead crane of the ABCS only needs to be able to position the element along the x, y and finally the vertical z-axis without need for complex orientation of the work piece. Adjustment and fixation are done by the connector system shown in *Figure 6-12 (right)*.

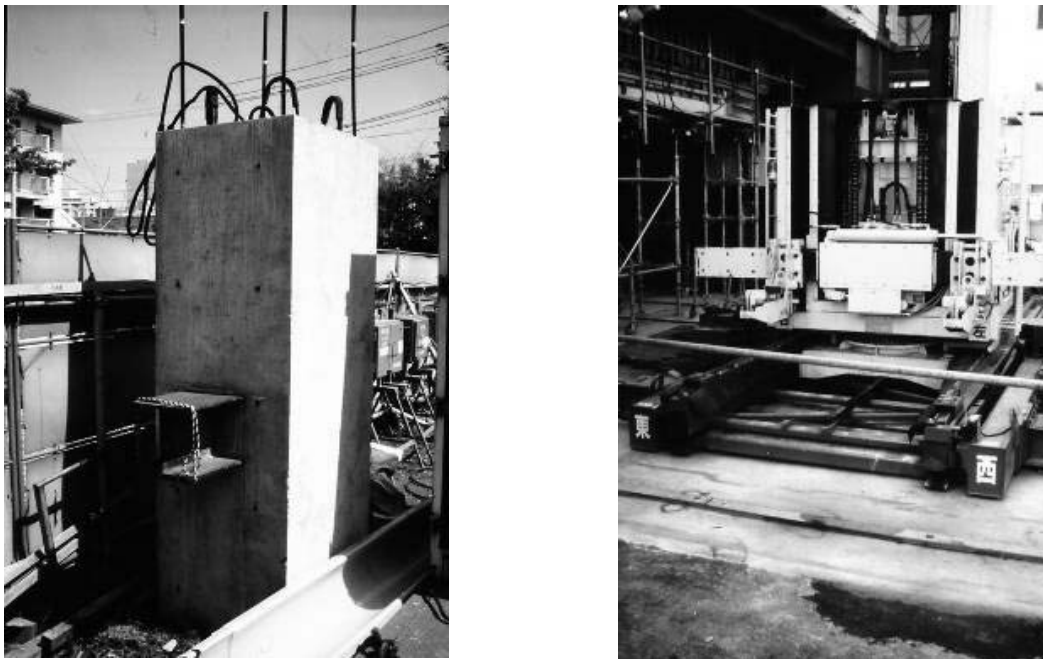

Figure 6-17: Complexity reduction through use of components on automated construction sites. Left: Prefabricated concrete component optimized for handling by robot. Right: rail-guided robot picking and positioning concrete elements.

6.2.11 Application of ROD in various architectonic scales

The concept of ROD meaning the co-adaptation of both the product (building) and the organization of technical systems that produce it can be considered and applied on various architectonic scales. This scale view is important as in architecture planning strategies, tools and processes are subject to scale, and different scales are often handled by different actors in the field. Civil engineers, architects, project consultants, contractors and sub-contractors handle the component scale, architects and other planners the building scale and city planners, landscape planners, developers and governments act on the master plan scale. All three scales are important parameters that have to be considered when integrated automated construction sites are applied.

- 1. ROD on a component scale:** ROD on the component scale refers to a design of building blocks as parts, components and modules, including joints and connectors that optimize the operation of a specific automated construction system. The design of the component can potentially reduce complexity in all 5 dimensions (kinematic/mechatronic; sensor, measuring and control; organizational; end-effector; informational). An example of excellent ROD on a component scale are Obayashi's Big Canopy applications (for further details, see **5.2.2**). Big Canopy is an integrated automated site system for the production of concrete buildings. The prefabricated concrete elements have been optimized in order to support an efficient operation of Big Canopy. The dimensions of the concrete elements are optimized so that they can be handled and transported by the robotic trolleys. Furthermore, the joints have been optimized to allow for a simplified positioning along the vertical axis. Alignment and fixation are supported by upwardly projecting reinforcing rods.
- 2. ROD on Building Scale:** ROD on a building scale refers to a design of the building on a more general level that ensures applicability of a specific automated construction system or optimizes its operation. ROD on a building scale refers to following design features:
 - Dimensions (rectangular, quadratic, etc.)
 - Orientation (vertical/horizontal)
 - Height/Length
 - Layout / floor plans
 - Structural system

For example, building shapes with corners could be produced by Shimizu's SMART (for further details, see **5.2.1**). The constraint is the dimensions of those corners are in tune with the dimensions of the cross-transportation-channels direction moving gantry profiles on which the trolleys at the end operate. Furthermore, the SMART has a higher potential to be optimized once the dimension of a building seen from atop is more quadratic than an elongated rectangular. Once a building becomes too elongated, several parallel-operated gantry crane profiles within one lane would hinder each other. It must be ensured that the travel distance from the

transportation channel does not become not too far. Other systems as e.g. Goyo's Faces (for further details, see **5.2.1**) are more optimized once the dimensions of a building seen from above is rather elongated rectangular than quadratic as its two heavy robotic cranes are intended for operation along elongated lanes. Another important issue is the height of the building. Systems intended for the production of more vertically oriented buildings require at least a minimum height in order to justify set-up time and set-up cost. Systems operating more in a horizontal direction require a certain minimum length and height in order to justify set-up time and set-up cost of rails and other equipment.

- 3. ROD on master plan scale:** ROD on the master plan scale refers to the design of settlements or urban structures optimized for the application of a specific automated construction site system. It has been outlined before, that height, form and orientation are features of a building that can be synchronized with the producing system. In a next step, developers might intend to apply a system set up in a specific location to an array of buildings located close to each other. Horizontally oriented systems such as the System of Skanska (for further details, see **5.2.5**), Neufert and Sommerfeld (for further details, see **5.2.7**) unlock their full potential once they are applied to an elongated housing construction. Those constructions might thus become a matter of settlement planning/urban planning. In Europe, for example, a lot of master plans for condominium areas are based on enlarged rows and orthogonal settings which would be an optimal basis for deployment of vertically oriented automated sites. Neufert in his *Bauordnungslehre* (**Neufert, 1943 see also 5.2.7**) even gave recommendations as to how a city plan has to be designed in order to fully utilize his so called "building ship". As the initial set-up of the system- as in the case of automated construction sites - is the most time consuming and costly issue, master plans can ensure that the site factory can be continuously operated along a trajectory with interruptions, or can with minimum effort be relocated on the ground without the need to fully disassemble them. In Asia for example vertically oriented automated construction sites could be applied to multiple vertically oriented buildings located next to each other. This practice would save logistics efforts and save set-up times, and could thus reduce the minimum height currently required for an individual high-rise in order to justify set-up time and set-up cost. Newly developed areas with arrays of low and high-rise buildings, as can be found for example in Incheon (Korea) or Shanghai (China) would provide the possibility to utilize master plans in order to optimize the application of automated construction site systems.

6.3 Conclusion: Novel ONM technology necessitates drastic Change of Industry and its Products

As discussed in **chapter 4**, a major intention of the development of Automated/Robotic On-site Factories was to outperform conventional construction as well as the approaches of LSP and STCR technology in order to multiply performance by machine technology as in other industries. Therefore, the direction was set towards integrating stand alone or STCR technology into structured factory-like on-site environments to networked machine systems. This approach intended to improve organization, integration and material flow on the construction site apart from the possibility to manufacture off-site and thus pre-structure components. The analysis in **chapter 5** showed that from the 1990s onwards the technical foundation for highly flexible and modular on-site factory technology was laid, but that efficiency improvement to date remained marginal. **In chapter 6** therefore it was discussed how individual subsystems could be arranged and integrated into real factories on-site in order to allow for further work activity parallelization and the optimization of the material flow. A radical approach to real-time and building integrated ONM was suggested and discussed, which would not only improve (e.g. as the above motioned management approach) or double productivity, but which would be able to multiply performance.

As discussed previously, automated manufacturing technology that accompanies a shift from an arts and crafts based industry to an industry based on systematization and machine technology needs to be able to not only improve or double productivity, but to multiply performance (e.g. reduction of construction time to 1/10th compared to conventional construction, zero-waste, and defect free products, see **3.3**). This can be achieved by the suggested approach by JIT, JIS material flow on-site on a 24/7 basis, reducing any idle or downtime in the site factory. Following the hypotheses set out in **1.6**, throughout **chapter 6** it was highlighted and discussed that the efficient deployment of Automated/Robotic On-site Factories and its sub-technologies necessitate not only a more radical change of manufacturing technology arrangement, but also a more radical and co-adapted change of the product and the buildings structure and modularity.

Although it was shown in **chapter 5** that the current generation of Automated/Robotic On-site Factories is not able to achieve a fast and real-time-like delivery of customized products (although it is able to customize on basis of automated manufacturing technology it is yet not able to that fast and efficient enough), the more radical approach presented and discussed in **chapter 6** would be able to do so. It was shown that a re-thinking of the approach on the basis of the formerly analyzed systems and technologies would be able to lay the basis for a construction industry which is able to produce or change buildings according to customer demands with minimal delay in a near real time manner. Furthermore it was shown that individual subsystems of the on-site factory, as well as sensor systems necessary to guide automated logistics and positioning operations on-site, can be integrated as building technology into the building and reactivated for change, re-customization and deconstruction during the building's life cycle. This idea will be further

formalized later by the concept of life-cycle integrated manufacturing technology, presented in **7.4**.

However, it was also shown that the novel approaches proposed would require a drastic and not easy (not easy means: not without funding programs, education, increase of R&D activity) change to the industry and in particular its organization and its products. In current construction practice, neither real modularity nor the applications of connectors that allow for simplified and fast connection are common practice. In order to structure the on-site environment and reduce complexity on-site (e.g. through the number of assembly operations, or kinematic complexity) an OEM-like industry structure, shifting the creation of components, modules and units to internal and external company suppliers and integrating the principles of ROD discussed in **chapter 6** has to accompany the introduction of Automated/Robotic On-site Factories.

7 Acceleration of Strategic and Technological Development by R&D and Innovation Methodology

In **chapter 6** a radical approach to real-time and building integrated manufacturing was proposed which builds on the advancement of the technology of the current generation of Automated/Robotic On-site Factories and its fusion with the novel technologies and approaches to more structured and integrated, flow-line like, super-fast and completely automated ONM settings.

The author of this thesis is well aware, that the required strategic and technological developments necessitate resources, funding programs, education, increase of R&D activity and systemic ways to innovate and/or transfer technologies. As the way to the suggested approach has yet to be pioneered in this chapter a roadmap to economic feasibility (see **7.1**) as well as methods for systemic and targeted innovation generation and management (see **7.2**) related to the approach presented in chapter 6 will be discussed.

It will be shown that an instant realization of Automated/Robotic On-site Factories through coordinated R&D and technology transfer as set out as hypothesis in **1.6** is difficult to achieve as the approach necessitates a co-adaptation of manufacturing technology, organizational structures and products and thus a radical change of the whole industry. The economic feasibility of automated on-site construction has so far not been the focus of R&D activity in the field. A combination of short-term funding, long-term funding of industry consortia representing the whole value chain, in combination with innovation and technology transfer strategies, can create in a step-by-step approach and by the combination of short-term and long-term development programs, and economically feasible approaches for automated/robotic on-site construction.

Finally, as a guideline for further development of and the integration of product structures, organizational aspects, informational aspects with the proposed ONM technology, a framework for the concept of life-cycle integrated manufacturing technology will be presented (see **7.4**). It will be shown that such a framework on basis of the manufacturing technology discussed in this thesis could turn manufacturing industry into an incubator and pioneer of future manufacturing systems for highly complex products (see **7.3**).

7.1 Roadmap to Economic Feasibility of Automated/Robotic On-site Factories

So far, the economic feasibility of automated on-site construction has not been the focus of R&D activity in the field. The LSP industry in Japan achieved economic feasibility from the end of the 1970s on in the housing market and was from the on not interested in developing its technology further or advancing to other markets than the housing market.

The first wave of R&D in automation and robotisation of on-site processes by STCRs (presented in detail in **4.1**) was concerned primarily with the analysis and imitation of construction processes and the technically focused development of elementary technology. The second wave of R&D from 1985 onwards, which was intended to network elementary technology to integrated automated sites (see **4** and in particular **4.2.6** and **4.2.7**) was mainly concerned with the aspect of integration and its implications on the construction process, building component structure and design (see **4.2.5**).

From 1995 onwards many of the developed integrated automated site systems which had been developed further technically, were tested to be used as hybrid half automated systems and subsystems and were used again by some companies as standalone technology in conventional construction projects - all of this was done more or less in a trial and error manner and without a general strategy aimed at economic feasibility. To date, the economic feasibility of automated construction sites – even in Japan – has not been achieved and most systems are used in commercial projects either to develop the technology further for clients who are willing to pay more for the application of the technology due to associated image factors (with the use of advanced technology the companies ordering such buildings show their positive attitude toward innovation and willingness to improve society). As stated earlier, Kajima's aim to make automated con- and deconstruction technology feasible through a coordinated subsequent application in more than 6-8 projects cannot, from the point of investment into a novel technology, be considered as economically feasible (likewise, see **2.1**, **5.4.2** and **6.1.4**).

Nevertheless, the development of automated deconstruction technology from 2008 onwards (see **5.3**), is an interesting and remarkable phenomenon, the application of the individual systems does not follow a larger strategy or the aim of significant economic feasibility. Similarly, as the application in construction projects the application in deconstruction projects is motivated more by "side" aspects as image factors, reduction of dust and noise, improvement of working conditions and the reduction of construction waste. Although Kajima's deconstruction system has some similarities with its automated construction method, deconstruction systems do not build upon the formerly developed construction systems and it can be assumed from the analysis that the deconstruction of most buildings once built by automated construction systems would be as difficult as the deconstruction of a conventionally built building. The integration with formerly developed construction technology has thus far not been accomplished.

7.1.1 Definition of parameters relevant for economic feasibility

In order to integrate aspects relevant for economic feasibility, the possibility of a building-integrated and hyper efficient approach to automated construction was developed and analyzed in 6.1. In this chapter, aspects are identified that, on the basis of the analysis of automated OFM (see 3.1 and 3.2), STCR technology (see 4.1), automated/robotic on-site factories (see 5.2), deconstruction technology (see 5.3) and the approach to hyper efficient automated construction, can be considered as relevant for economic feasibility. Economic feasibility can be achieved when the following parameters are integrated by or along with the in 6.1 presented approach:

- 1. Deployment of an OEM-like industry structure:** In order to achieve a reduction of the depth of added value on the construction site and thus a reduction of the complexity and amount of activities, work tasks and operations to be performed, is a prejudice for the possibility of application of automation on-site. The (especially in Japan) strong LSP companies could become Tier-1 suppliers of high-level components (units). Design and structure of buildings must be changed and buildings must be modularized in a way which allows the manufacturing and step-by-step integration of individual building blocks off-site by Tier-n suppliers. For the LSP industry, the integration into this OEM-structure for the manufacturing of buildings for the non-housing market would represent an opening up of a novel market which does not exist in today's market.
- 2. Possibility of rapid start of income generated by building:** The reduction of the time necessary for construction on-site has to be reduced significantly. The approach discussed previously (see in particular 6.1.1 and 6.1.4) suggests a reduction to one-tenth of the time necessary for conventional construction. The on-site construction process for larger buildings could thus be reduced to about one month. The LSP of units and components would account for a lead time of about one month, considering the current state of the art of technology in the LSP industry. However, technological and organisational improvements could improve the lead time further. Assuming that the cost of construction does not rise compared to conventional construction, through earlier completion (completion within two months instead of 20 months), income payments start earlier and developers can pay back loans faster and have to pay less interest rates. The realized gains can be partly handed over to the customer as well as to the supply chain.
- 3. Real-time construction: enhancement of product value through fast availability:** The fast or nearly instant availability of buildings, with them the associated functionality would enhance the value of the product for the customer. During long construction projects the local economic situation can change and negatively affect the assumed building value. With rapid or nearly instant availability, demand and fulfilment could be aligned to each other in nearly real time, according to the philosophy of the RTE. Shortened construction periods could also be used gain time for the adaptation of the building product to customer demands.

- 4. Enhancement of product value through integrated maintenance, rearrangement and deconstruction technology:** The enduring integration of the automated construction technology into the building after completion, and its use for automated maintenance, re-arrangement and deconstruction, enhances the value of the building and the level of the income payments generated by the building. Higher income payments can be used to compensate for the cost of the automated construction technology (GF, GSSF, crabs, etc., see also **6.1.9** and **6.1.12**). The cost for the novel construction technology can thus be partly integrated into the budgets for building technology, maintenance and facility managements.
- 5. Reduction of costs associated with project management, project controlling, security, health, quality assurance and defect compensation:** The costs associated with the control of the construction progress in conventional construction (project management and project controlling) can be reduced to near zero. With automated construction, the building is manufactured in a factory-like off- and on-site environment, strictly according to plan, and as the technology allows a real-time monitoring of the construction process, for example with an RTMMS (see also **5.2**, **5.3** and **5.4**), the technology integratively performs this tasks. Furthermore, working conditions are enhanced and the risk of accidents is reduced considerably. As stated earlier (see **2.1**), a safe and healthy construction environment influences quality of work. Through automation, SE, improved working conditions and real time monitoring, a higher quality of building product and a low defect rate can be guaranteed. As stated previously, the defect cost in Germany in the construction industry accounts for more than 2.8 billion euros (not including costs for lawyers etc.) and thus bears the potential for considerable savings by automation.
- 6. Resource Productivity - Reduction of resource consumption on project, firm, greater economic and societal level:** LSP currently gives the possibility to apply a zero-waste manufacturing process and to re-customize units (see **3.2** and also **6.2.1** and **6.2.10**). The current state of automated on-site construction allows a reduction of the generated waste volume of up to 80%. The approach of integrated building manufacturing (see **6.1** and in particular **6.1.13**) would allow off-site and ONM processes to be integrated into one zero-waste manufacturing chain. Additionally, the ability to exchange units during the life-cycle enhances the lifetime of the building. The exchanged or deconstructed units can be customized in the factory. Thus, the melting and reforming of the steel frames – a resources and energy consuming activity – is avoided. If the building integrated construction and robot technology were to be applied on a large scale (e.g. within a city), units could then be automatically relocated from one building to locations in other buildings, or back to the factory for re-customization.
- 7. Enhancement of product value through guaranteed fixed quality, fixed cost and delivery fixed time:** The deviation of cost, quality and construction time is, for the investment in buildings by investors, developers and their clients, the highest risk (see **2.1**). As automated construction progresses off-site, as well as on-site according to fixed production plans, and as automated construction minimizes the deviation of costs,

quality and construction time by reducing the risk factor “human work” to a minimum, it is able to guarantee fixed quality, fixed cost and delivery fixed time. This risk minimization enhances the value of the building product.

- 8. Achievement of high rate of capacity utilization of means of production:** The reduction of the net construction time on-site to one tenth of the time necessary in conventional construction allows the means of production bound by a specific project (including know-how, supervisors, engineers, etc.) to become available for new projects much faster. The utilization rate would be enhanced and the amount of buildings necessary to be completed for compensation of development and deployment cost of the novel technology could be reduced to 1-3 years, which from an investment point of view would be feasible.
- 9. Opening up of novel markets:** Automated construction through the reduction of the factor “human work” provides novel business opportunities in the “3D” project field (that is to say Dull, Dirty and Dangerous). Large and repetitive structures (space structures, super tall buildings, marine structure, sub-marine structures, arctic structures and desert structures, see also **6.1.15**) could be built up quickly and efficiently, and without interruption to which human work is usually subject to in harsh and unforeseeable environments. The possibility of constructing and deploying architectural structures efficiently in those environments would create novel business opportunities for developers, constructors and architects, as well as for the industries for which those buildings would be constructed. R&D in the above mentioned field could be seen as an innovation field complementary to R&D in automation and robotics in construction.
- 10. Reduction of cost for development of the novel construction technology through consequent know-how and technology transfer:** The consequent transfer of know-how and technology from other industries could reduce the time necessary for development as well as the development cost. Today, the transfer of technology from the highly automated automotive industry to the aircraft industry (which intends to cross the border from mechanization to automation) is common practice. This practice is able to reduce time and cost of development by up to 50% (Siewert, **2012**). It can also be shown that Japanese production-line based LSP is based on manufacturing technology transferred from the automotive industry (e.g. production line, see **3.2** and **3.3.4**) and that state-of-the-art automated construction sites were inspired by ship building (see also, **7.2.2**). For the approach to real-time and building-integrated automated construction, a set of elementary technologies that could be used and transferred was suggested (see **6.1.6**). Furthermore, sets of existing and upcoming technologies with relevance to the suggested approach can be systematically identified (see **7.2.4**). **Chapter 7** discusses methods of innovation generation and the possibility of know-how and technology transfer into construction industry. Know-how and technology transfer can be considered as a key-concept for the fast and efficient development of a next generation of automated construction technology. The application of transfer strategies should be supported by funding programs as well as by universities and other

institutions training the engineers that intend to work in the construction and architectural engineering field.

- 11. Development and Deployment of automation compatible building standards on the basis of common coordination measurement system (BMU):** The Japanese LSP industry achieves high efficiency by automated OFM, and has therefore changed the traditional designs of buildings and components (see **3.2.1**, **3.2.2** and **3.2.3**). The deployment of Automated/Robotic On-site Factories (see **chapter 5**), necessitated changes to design and building structure and applied ROD on various levels (see in particular **6.2**). However, the changes have not yet been able to achieve high efficiency. In **6.1** it was suggested that in order to achieve maximum performance of automated on-site construction, building dimensions, construction technology, building blocks, operational sequence and logistics structure would have to be fully synchronized with each other by a BMU modular coordination measurement system. Parallel to the development of construction automation technology on the basis of BMU, the BMU measurement system must be applied as a standard in the architectural as well as in the logistics field.

- 12. Development and deployment of fast joining and fast connector technology:** Along with the BMU measurement coordination system, the development of fast joining and fast connector technology is a key-concept for technically enabling automation on the construction site. Fast joining and fast connector technology is able to reduce the complexity on the construction site. It can reduce kinematic/mechatronic complexity by simplifying the installation of components or units (see **6.2.4**). Compliant jointing systems can reduce the need for complex, error prone and costly sensor, process measurement and control technology (see **6.2.5**). Combinations of compliant jointing systems and fast joining/connector technology can further reduce the overall organisational complexity on-site (see **6.2.6**). Various types of fast connectors have been discussed in **2.2**. In relation to the approach suggested in **6.1**, the use of fast connector technology for the installation of units and superstructure elements by the robotic crabs was suggested (see chapter in particular **6.1.9**). Fast connector technology reduces complexity on-site but necessitates the building up highly specialized engineering know-how.

- 13. Step-by-step building up of technology and associated know-how by national and international funding programs:** The change to real-time and building-integrated automated construction (**6.1**) would necessitate a change of construction technology (, see **6.1.6**), building design (see **6.1.5** and **6.1.8**), organizational structure (see **6.1.2**), employment structure (see **6.1.12**) and the general re-organization of the construction industry (see **6.1.13**). Enormous financial input would be necessary for the development of the concept, and the engineering of the associated technologies and processes. Furthermore, the change would require engineers to have the know-how concerning technology and organisational change. National and international funding programs support universities in training people and building up the necessary know-how, they can provide the networking basis for the creation of new, interdisciplinary consortia

spanning the value system (developers, contractors, investors, clients, specialized machine/robot builders, etc.) and of course they can, through funding, minimize the financial risk of all involved parties.

14. Build-up of a supportive legal framework: Besides the short-term and mid-term support by funding programs, a legal framework has to be established that gives incentives to apply the novel on-site manufacturing technology in construction. Such a legal framework could, for example, regulate project specific financial support for application of technology because of the reduction of the disturbance to the surrounding environment. Furthermore, the legal framework could give incentives for the use of the building integrated approach by rewarding the saving of resources and energy e.g. through direct re-use, customization or deconstruction. For projects that are in areas that are have a high relevance for the public (e.g. stations, airports, schools, large condominium projects, etc.) a legal framework could even make the application of the technology compulsory.

7.1.2 Economic feasibility on different levels

Similar to other efficiency relevant parameters, economic feasibility can be considered on various scales/levels:

1. Work task/machine level
2. Project/factory level
3. Firm level
4. Greater economic level (firm networks, industry, etc.)

Another level can also be added, which will be explored further:

5. National economics and societal level:
 - Reduction of disturbance of surrounding: considers the possibility analyzed in **6.1** of significantly reducing the disturbance to the surroundings which leads then to efficiency on a greater level.
 - Improvement of resource efficiency: In **2.1** it was shown that the construction industry consumes tremendous amounts of resources, but generates a relatively low monetary output. Automated construction sites maximize construction waste and improve time resource efficiency at the same, through the ability for reconfiguration, unit-customization and controlled deconstruction.
 - Reduction of cost for public caused by unhealthy working conditions, accidents and fatalities: As shown in **2.1**, the construction industry is among the most dangerous industries. The analysis of Automated/Robotic On-site Factories showed that this approach significantly improves working conditions and reduces the risk of accidents and fatalities to near zero (see in particular **5.4** and **5.5**).
 - Image of German Industry: As shown in **2.1**, the construction industry has the lowest capital stock and the lowest capital-output ratio. This performance negatively affects

the image of the German industry in total, as Germany is usually associated with high-tech, engineering skill and efficiency. Once automation is developed and deployed, construction can become a novel channel for selling German high-tech and specialized machine technology.

- **Wages and Employment Structure:** Construction in general has a low wage level compared to the automotive or aircraft industries. Usually, with a rising degree of mechanization or automation, wages – also for workers on the shop floor – rise. Automation in construction and especially the suggested approaches could lead to significantly enhanced wages and minimize the need for unskilled workers, but enhance the demand for engineering know-how.

An important issue related to the national economics and societal level is the image and employment structure in the construction industry and thus the associated attractiveness of the industry. The attractiveness of an industry should not be underestimated, as it influences the value and image of the product as well as the availability of skilled workforce (engineers as well as workers). The salaries for shop floor workers in the construction sector worldwide, as well as the average salary in the construction industry, are among the lowest compared to other industrial sectors. Also, as discussed at the beginning of this thesis (see **2.1**), conventional construction is related with a lot of risks for the workers in terms of health and safety. The construction industry is among the four most dangerous industries (see **2.1**) and is, in many aspects, associated with “3D” (Dull, Dirty and Dangerous) tasks.

A study of the German construction employment market by the Federal Employment Office in 2010 (**Grunau & Hartung, 2012**) showed that on the one hand, in the non-academic field, the unemployment rate in construction, as well as the rate of people who quit apprenticeship or training is above average, compared to other industries. On the other hand, the number of engineers and architects is growing steadily, leading also to sinking employment chances and wages in the field. The change to real-time and building integrated automated construction would on the one hand enhance the attractiveness of non-academic shop floor-like work (more skill necessary, higher salary, better working environment, less risk for health and safety, chance to work with advanced technology) and on the other hand enhance the need for skilled engineers and technology oriented architects, and thus coincide with the currently growing number of engineers and architects.

A high tech oriented construction industry would also be more attractive to the elite of skilled R&D staff and engineers that usually go for jobs in the aircraft, space, automotive or industrial engineering industry. Salary and attractiveness of work in generally tend to rise with the level of automation. Both engineering jobs, and shop floor and assembly line jobs, for example in the German automotive industry (e.g. BMW, Audi, VW) or aircraft industry (Eurocopter, Airbus) are highly attractive. The analysis of the efficiency of Automated/Robotic On-site Factories (see in particular **5.4.2**) showed that both work environment (working condition, health safety) and work level (skill necessary, work with advanced technology) can be enhanced through the deployment of the novel ONM technology (see also *Figure 7-1*). The analysis also showed that the need for automation

engineers and workers who control or supervise the operation of the systems on-site rises whereas the amount of workers necessary for “3D” (Dully, Dirty and Dangerous) tasks is sharply reduced (see 5.4.2). Furthermore, usability studies showed the positive influence of the novel work environment on workers’ motivation (see 5.4.2).



Figure 7-1: Left: female worker on the construction site remote controlling and supervising the operation of ABCS subsystems. Right: Worker in control room supervising processes and construction progress.

7.1.3 Future Funding Program Strategy

In order to create a sustainable and enduring innovation, it is necessary for greater strategies and funding programs to enable individual firms or firm networks to achieve economic feasibility on smaller scales as fast as possible. The achievement of economic feasibility on national economics and on a societal level (reduction of disturbance possibility to reduce resource consumption) is important to achieve broad acceptance of the change in construction, but it is only of secondary importance. Only if the technology gets into the realm of economic feasibility during the period of state funding, and there is adoption and large scale deployment of the technology, can enduring feasibility on national economics and societal level be guaranteed. The stagnation of the site automation technology after intensive state funding and nationally coordinated activities in the 1980s and 1990s in Japan can be definitely related to the fact that during that period the technology was not brought into the realm of economic feasibility (see developments and systems analyzed in 4.1 and 4.2).

For a fast and enduring deployment of automated construction technology, it is thus important that economic feasibility on low-levels is established quickly and consequent. Parameters related to the reduction of construction time and cost, on the one hand, and the

enhancement of the monetary measurable product value on the other, can thus be considered as the most important ones.

Large scale funding programs are a common way to deploy novel strategies and technologies in an industry or in industries which are not yet economically feasible. Usually companies cover innovations and technologies which are applicable within a few product generations, or within a market research foreseeable time frame of 2 to 5 years (smaller companies usually have fewer resources for change and innovation than larger companies but are, on the other hand, more flexible). The development of strategies and technologies which exceed that time frame, which are additionally complex and from which one does not know for sure if they will really make it into the market, represents a risk for companies, which they usually cannot bear on their own. National and international funding programs which support the development of innovative strategies and technologies have the aim of mitigating the risk for companies and at the same time supporting them in acquiring the necessary know-how (e.g. through cooperation with R&D institutes and universities) and in networking with other relevant players in the field. Funding programs can direct the technological development of existing industries, strengthen industrial locations and even create more or less new industries (as has been done in Germany, for example, by the funding programs for the solar panel industry and on a European level with the Ambient Assisted Living program).

The Ambient Assisted living program was initiated in 2006. It aims at turning the problem of the demographic change into a new business opportunity for Germany's high-tech industry. Advanced assistance technologies should allow elderly people to grow old at home and remain self-sufficient. The program thus also addresses the growing lack of doctors and care personnel and the rising cost of care for the public. Besides working groups and conferences, the program, via the Federal Ministry of Education and Research (*Bundesministerium für Bildung und Forschung*, BMBF), funds interdisciplinary university-industry consortia. Since its initiation, the program in Germany has funded consortia with more than €800 million. Developments in the AAL field are considered to be a complex innovation, as for the realization of a novel assistance system, know-how and technologies from very different fields (sensors, mechatronics, robotics, social sciences, geriatric knowledge, care work, psychology) has to be fused to a socio-technical system. A speciality of the program is that the funding line requires consortia to represent the whole value chain (from technology providers to primary and secondary end users). Furthermore, funded projects should be structured in a way that allows the developed strategies and technologies to be on the market within a time frame of two years after the project's end. All in all, the entire program is highly application oriented; companies are usually appointed consortia leaders in funded projects

Funding programs such as the Excellence Cluster CoTeSys (Cognition for Technical Systems) or ECHORD (European Clearing House for Open Robotics Development) are more oriented towards basic research and aim more at universities as leading partners. Projects in such funding lines show a higher degree of innovation and are intended to pay off in the long-term. Economic feasibility – in contrast to the AAL funding program – is not a

major issue in those more technically oriented funding lines. Both short-term and long-term funding models have their advantages and disadvantages. The short-term model ensures that innovations are based on the economic environment, that economic feasibility of the newly developed strategies and technologies is at least to some degree guaranteed, and that players from different fields are connected, later forming the value system or value chain. The long-term model is more likely to generate a higher degree of innovation and a more advanced state or complexity of individual technologies or aspects.

A weakness of the Japanese funding model in general, is that funding strategies are often long-term oriented and that fewer opportunities exist for university/industry cooperations and for the forming of highly interdisciplinary consortia representing the value chain. Research is less application oriented. On the one hand, the long-term orientation of Japanese research has, in the 1980s and 1990s, generated technologically advanced automation and robot systems for the construction site. In Europe and the USA, where research is more short-term and oriented towards economic feasibility, research in that field has never been conducted with such intensity, and the ideas and proposals were not as outstanding and innovative as, for example, the Japanese approach to integrated automated construction sites. On the other hand, automated construction sites to date (also in Japan) are have not been fully integrated into the construction economic environment and organisational structures and are only under certain circumstances (see efficiency analysis, **5.4.2** and also **5.5**) economically feasible.

The development of automated construction sites by Japanese companies evolved under the lead of a main contractor (e.g. Shimizu, Kajima), technology providers (e.g. Komatsu, Hitachi), and, seen from a technological perspective, successfully achieved advanced performance (some systems were even capable of full automation of the component installation process!). However, the development consortia and projects did not fully integrate the value system or value chain as, for example, is done today in Germany by the AAL-funding line. Thanks to Japanese R&D in the 1980 and 1990s, the conceptual, strategic and technological basis for automated construction sites still exists today. As a result, future funding programs can cover both long-term and short-term R&D activity, or even focus on short-term applicability and economic feasibility. A future funding initiative or program for real-time and building integrated automated construction should therefore cover the following elements:

6. Founding of a central coordinating initiative or institution which is jointly supported (monetary and non-monetary resources) by several associations: association of German engineers (VDI), German electrical engineering association (VDE), association of German machine and plant engineering and construction (VDMA), association of German construction industry, association of German architects (BDA), European Robotics Technology Platform
7. Coordination of working groups: working groups consisting of scientists and practitioners spanning the whole potential value system must be formed. Working groups can cover the 14-point topics as mentioned above under section 2 of this chapter.

8. Funding of interdisciplinary consortia through calls for proposals (applied research, short-term): As stated above, the economic feasibility should be a key issue in a novel attempt to build up automation and robotics in construction. The initiative should therefore issue calls for proposals for university/industry cooperative projects. Consortia should be interdisciplinary, span the whole value chain and contain up to ten partners (up to two research institutes or universities). The applicability of the developed strategies and technologies after the end of the funding period (2-5 years) should be in focus.
9. Funding and initiation of complementary teaching activities: Teaching activities should be initiated that build up engineering know-how (e.g. through new Masters Courses) on the one hand, and which, on the other hand, teach developers, contractors and workers how to successfully apply the new technology.
10. Funding of basic research and highly innovative projects (long-term): Apart from the funding of application oriented consortia, individual, highly innovative projects and scientists should be supported in developing further their ideas and concepts on a more experimental level.
11. Accompanying contract research: The central initiative should commission studies and market research to provide basic information to all players in the field.
12. Establishment of a central construction automation research institute: As stated earlier, R&D spending in construction is extremely low compared to other industries (see **2.1**). Furthermore but in the architectural and civil engineering field, applied research is, compared to other industries, not common case. In order to provide incentives, show directions and develop research methods, it would therefore be of strategic interest to found an independent central construction automation research institute.
13. Conferences & Publications Platform: Initiation of an annual conference organized by the coordinating initiative or institution which addresses both academics and practitioners.
14. Promotion at international congresses and trade fairs: Acquiring of exhibition space on trade fairs and international congresses for the presentation of developments, research outcome and outcome of funding programs in order to attract new enterprises and supporters,
15. Cooperation with politics and legislative authority: Cooperation with politics and legal authorities should identify the need for complementary decisions and changes at that level. As the industry structure will completely change, complementary changes on legal, political and institutional level will be necessary.
16. External Communications Committee: Promotion of the new technology in the public (magazines, daily press, etc.)

At the beginning of this thesis, the advantages and disadvantages of modular structures were discussed (see **2.2**). It was outlined that the construction industry, in contrast to the automotive or computer industry, is not yet based on modularity. The switch to an OEM-like module supplying structures as proposed in **6.1** would serve as the basis for the reduction of on-site assembly complexity, and thus for the introduction of automation and robotics in

construction. Baldwin & Clark (2000) further argue that the deployment of a modular structure on a product level, design level, manufacturing level and on a level of the economic surrounding (enterprises) are key to a rapid evolution, as it allows for frequent improvements and exchanges of modules. Furthermore, modularity reduced the development complexity as it allows the task to be split up into sub-tasks which can then be solved by highly specialized entities of the economic environment. The introduction of modularity on all levels (product, design, manufacturing, logistics, etc., for further information see 2.2) as well as the generation of efficient interfaces and connection standards should be a fundamental issue of a funding program. Standards for measurement systems, module sizes and interfaces can be introduced on a soft level at first (e.g. by requiring companies and consortia that are funded by the program to stick closely to certain standards that guarantee interoperability as well as exchangeability) and later on as solid standard, fixed by DIN or ISO norms.

7.2 Utilizing Innovation Science to Develop and Deploy Automated/Robotic On-site Factories

In **6.1**, an approach for real-time and building integrated automated manufacturing was presented. The approach is itself an innovation and requires the integration of a multitude of complementary strategic and technological innovations for its realization. A set of related technologies and concepts already realized in other industries and having a high potential to be used as a basis for the realization of the suggested approach was given in **3.3** (in particular TBM tunnelling, ship-building and aircraft manufacturing) and **6.1.6** (new elementary technology). In **7.1**, it was discussed that the achievement of economic feasibility of automated construction would be a key issue for future development phases and that a targeted funding project could minimize the risk for companies in a transition period from conventional to automated construction.

In parallel, it is important that methods are developed which allow, in terms of time, resources and financial input, an efficient development of the necessary strategies and technologies. As stated earlier (for example, see **6.1.2**, **6.1.3** and **6.1.4**), it is important that a new attempt to automate in construction reaches economic feasibility and technological robustness faster than the systems developed during the 1990s in Japan, and which are still currently in operation. In this chapter, therefore, relevant innovation mechanisms are analyzed. Firstly, the current state of innovation science in general is briefly outlined. Secondly, innovation mechanisms in construction are identified and a comprehensive framework for the analysis and generation of innovation in construction is presented. Finally, in this section, strategies and technologies that would be compatible with the presented approaches and which could be used to detail, improve or extend them are identified and suggestions are made as to how those could be used specifically in the innovation process related to the approaches for real-time and building integrated automation which was discussed in detail in **6.1**.

In this chapter, sub-chapters **7.2.1**, **7.2.2** and **7.2.3** are based on an approach presented by the author of this thesis at the Creative Construction Conference in July 2012. The approach has been furthered, adjusted and integrated with the argumentation lines and approaches presented in this thesis. Text parts transferred from the original conference publication into this thesis have been reworked, extended and rewritten.

7.2.1 Innovation Mechanisms in General

Technology and innovation management in general are well deployed research fields. An outstanding collection of essays covering the whole field of innovation and innovation management can be found in Christensen et al., (2001). Basic tools, strategies and different viewpoints on innovation for the integration of technological, market and organizational change are **discussed by Tidd & Bessant (2009)**. Creativity strategies and techniques have been presented and analyzed by Hartschen et al., (2006) and Backerra et al., (2002).

Modularity as the driver for systemic and controllable innovation has been analyzed by Baldwin & Clark (2000) and Fujimoto (1999), by using the computer industry and by using the TPS as examples of the phenomenon of evolutionary organizational change. Further concepts of creating innovation quickly and efficiently by opening up products and services to customer co-creation (Reichwald & Piller, 2009) have been developed and advanced by concepts about crowd sourcing (Howe, 2009), open innovation (Chesbrough et al., 2008), and open service innovation (Chesbrough, 2011). The potential impact of spreading computer technology and social-networking systems on industry, research and society, have also been analyzed (Tapscott & Williams, 2010).

Typological Viewpoint

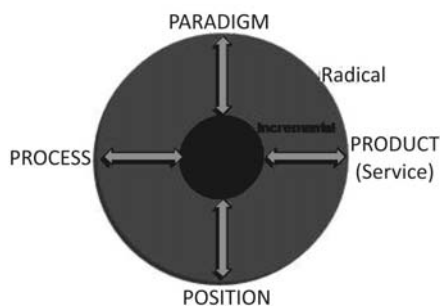

System Viewpoint

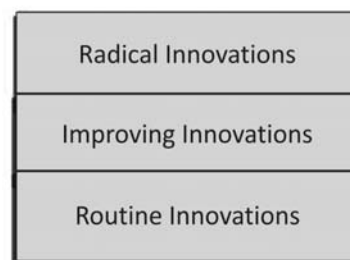
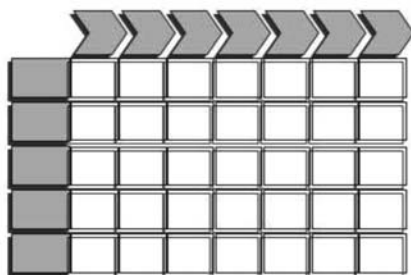
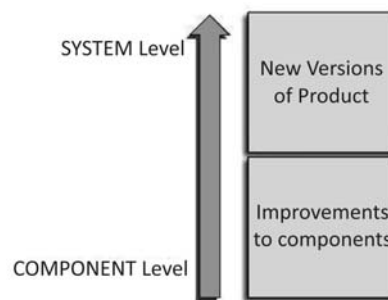

Process Viewpoint

Novelty Level Viewpoint

Figure 7-2: Classification of innovation generation frameworks developed within general (not construction specific) innovation science

Furthermore, important research has been conducted by Cameroon & Green (2009) and Hayes (2010) which sees innovation as a kind of change, which has to be managed carefully as multiple actors are involved. In general, the research field *change management* argues that human beings or organizations are often reluctant to change, as existing structures, power distribution and revenue streams are changed, and thus the real innovation is to convince actors and change their mindset by incentives. However, specific concepts, strategies and literature on the impact of change and the deployment of

innovation in the construction industry are rare. Individual aspects of deploying innovation in the construction industry as the concept of creating innovation by developing technologies for extreme environments (Linner & Bock, 2010) and by transferring technologies between ship building and construction industry (Bock et al., 2011a) have been explored by the authors. Additionally, the authors have analyzed the possibility of deploying advanced construction technology (Bock et al., 2011b) and product and service innovation within the construction industry (Linner & Bock, 2012). Although individual aspects of innovation in construction have been discussed, a comprehensive framework that can be used for the systemic classification and generation of innovation in the construction industry has not been developed yet.

In general (not construction specific) innovation science, various viewpoints have been established to look into the potential innovation space and to define in which context the existing product, service or process and the intended change is situated. Important viewpoints are: typological viewpoint, system viewpoint, process viewpoint and novelty level viewpoint (Figure 7-2).

Typological Viewpoint: The “4-P” diagram represents an example of a typological view on innovation. Innovations are classified and then arranged within the diagram. Four classes of innovation are defined within this diagram.

- Paradigm: refers to innovations or major changes in underlying mental models or simply to mega trends, such as “E-Mobility”, “Ageing Society”, “Energy Efficiency” or trends such as the ongoing spread of small computation devices (“Ubiquitous Computing”).
- Product: refers to an innovation on product level.
- Position: refers to the presentation of an existing product or technology in another context.
- Process: refers to innovations in the manufacturing field related to a product.

System Viewpoint: Within a system viewpoint, the product, the product/service system, including the economic, managerial and social surrounding in which the item of consideration is situated, is hierarchically structured into systems and (a multitude of) subsystems. The sub-division into subsystems can go down to the component or even parts level. In a further step, it is decided within which system levels the change or innovation is situated, or has to be created e.g. on system level or only on a component level. A change on a system level is, in most cases, more complex as a multitude of subsystems is affected. On the other hand, a change of a single component at a subsystem level might not necessarily affect the overall system or other components. The system viewpoint is closely related to aspects of modularity and modularization as discussed in 2.2. As stated previously (see 2.2), modularization and thus the clear division into systems and subsystems can considerably influence development and innovation speed.

Process Viewpoint: The process viewpoint utilizes the fact that every product or service is relative to time and thus embedded in a process which often involves many actors (users,

sellers, providers, producers, integrators, etc.) over time. An example for a creativity tool based on the process viewpoint is the Customer Value Matrix:

1. Along the horizontal axis: the process in which the product is embedded is sequentially laid down.
2. Along the vertical axis: influential factors such as, for example, risk, fun factor or added value are organized. All steps in the process are analyzed in relation to each influential factor.

Novelty Level Viewpoint: From the novelty level viewpoint, it is important to identify and, if possible, quantify the novelty of a proposed innovation or change. Here, the most common classification is the bipolar classification into “incremental” and “disruptive” innovation. Another classification system subdivides into “routine innovation”, “improving innovation” and “radical innovation”. A routine innovation is an innovation, for example, on the level of a daily work routine; an improving innovation might be the introduction of a new product or service to be delivered; and a radical innovation might be the change towards a completely novel type of product (e.g. from looms to cars as was done by Toyota). Here it has to be noted that more radical innovations often necessitate other complementary innovations. In **6.2** it was shown that the approaches are more efficient when not only the automation technology is advanced but when the building structure, industry structure and related business models are also adjusted.

When developing an innovation, the aforementioned viewpoints can be applied in parallel, and the potential innovation space can thus be identified and analyzed systematically. All views have their strengths and weaknesses. The system viewpoint, for example, can precisely define which parts of a system shall be affected by the change to be introduced. The viewpoint can identify multiple factors for change of even complementary innovations that would be necessarily seen over the whole process chain. What all viewpoints have in common is that the levels or systems into which they are classified and or are subdivided are quite relative. This refers to the general problem that it is possible to qualify innovation relatively easy, but difficult to quantify it.

7.2.2 Innovation Mechanisms in Construction

The following section summarizes an analysis and categorization of innovation mechanisms in the construction industry. The backgrounds and details of the analysis were outlined by Bock et al. (2012). According to the notion of DfX, an open IbX (Innovation by X) categorization is suggested. The categorization system can be extended by a new category (and thus X) once a new mechanism is identified in the future.

- Innovation by Production Technology (IbPT)
- Innovation by Modularity (IbM)
- Innovation by Product Performance (IbP)
- Innovation by Technology Transfer (IbTT)
- Innovation by Transformation (IbT)

- Innovation by Overlay (IbO)
- Innovation by Customer (IbC)

Innovation by Production Technology: One important innovation is IbPT, which is common in automotive industry. While the offered price for a car remains constant, the amount of features and technology increase (**Radke et al., 2004**). The competition between the production companies plays an important role. So it is significant to optimize the production process and reduce production costs. The money saved will be invested in research, development, increasing technology and also for optimization of the production process. This enables the companies to offer a better featured car with a constant price (see also *Figure 8-1* in **chapter 8**). Such a development can only be triggered by highly technological and automation based systems. Labor based production systems such as in conventional construction have, due to human nature, a natural limitation, whereas technology-based production systems have virtually no limitation in performance (see also **2.1, 2.4** and in particular **3.3.6**). In the construction industry, advanced technologies and features (smart homes, Ambient Assisted Living Technology), still accounts for additional costs on top of the already tremendous costs (compared to other products). The radical improvement of the construction process efficiency, as suggested in **6.1** could be used to free budgets for the development and deployment of better building technology and buildings with more “features”.

Innovation by Modularity: The modular structure of a product has an impact on all phases of its life cycle: development, planning, production, sales and use/customer (see also **2.2**). Thus, Modularity is important to manage the product and control its success over the whole life cycle. Open and changeable modular designs that allow the designers and engineers to improve or adapt a product continuously are of relevance for controlling change and innovation processes. The modular structure can be set up in a way that makes it possible for individual modules and components of a product to be exchanged by new or upgraded designs, or for new/novel features to be added without making it necessary to abandon or re-engineer the whole product for a new-product series. Some companies, such as manufacturers of high-tech cars in Germany or housing LSP companies, sometimes make more than a hundred changes to a product per year. Sekisui Heim, a Japanese prefab building manufacturer introduces about ten new housing models and about 400 modifications and improvements to existing solutions annually (**Furuse & Katano, 2006**) – change at that frequency can only be accomplished efficiently through advanced modularity, based on OES principles. The modules that are not exchanged during OES improvement guarantee stable processes in logistics, production and sales. As discussed in detail in **6.1.9**, modularization for real-time and building integrated automated manufacturing can be done on the basis of the BMU measurement system.

Innovation by Performance: Today, the complexity of buildings continues to rise rapidly due to new paradigms, such as the demand for energy efficiency, and emerging assistance technologies. Buildings are becoming integrated with a multitude of new subsystems and are extending their performance to areas that have not formerly been counted as being part of the construction and building industry, but are now gradually merging with our built

environment. With the integration of micro systems technology into buildings, and due to the tendency towards enhanced user integration and towards MC (Piller, 2006), buildings are becoming not only more intelligent, but they can now be personalized much more to meet the needs of the inhabitants, and could further serve as platforms for a multitude of continuous and commercial services. These changes could have a tremendous impact on the whole value chain and are likely to transform building structures, construction technologies and business models. For example, the production of a building in a controlled factory environment is highly demanded when buildings are equipped with a multitude of complex and advanced technologies, as this type of production could control complexity, price and quality. Complex building technologies necessitate the precision and performance of machine based manufacturing systems. The 7-DCI Diagram discussed later will return to the idea of complementary and interconnected innovation.

Innovation by Technology Transfer (IbTT): As the name suggests, existing production systems can be used in another context. For example, in shipbuilding and aircraft construction, underslung cranes (roof) and rail systems (on the ground) are used, which can be supportive in assembling buildings in automated/robotic on-site GFs. For example, an Airbus A380 is produced using on-site construction, and applied rail-guided, automation. The Japanese company Kajima used this idea for its AMURAD (Automatic Up-Rising Construction by Advanced Technique, see 5.2.4). The “field factory” is located on the ground floor as an on-site construction site, and a robotic system produces each floor from concrete components. Subsequently, all finished floors are pushed upwards by a hydraulic press system, and then the next floor is also built on the ground level. As early as 1945, the Warnow wharf was already applying cable cranes for a dry dock production with parallel processing trolleys (presented in detail in 3.3.2). The SMART system of the company, Shimizu, has similarities to the parallel processing trolleys (see 5.2.1). In comparison to Kajima’s AMURAD, the “field factory” of the system isn’t placed on the ground level, but it moves upwards with each produced floor. In post-war Germany Neufert also worked on mechanized and weatherproof construction sites, where multiple trolleys work in parallel (see 5.2.7). Besides automated trolley hoist systems, construction companies such as Shimizu, Obayashi and Samsung have transferred technologies for automated steel welding, which have been well deployed within the ship building industry, to the construction industry (for more details about welding robot technology on construction sites, see 4.1.9 and also 5.2). Therefore, those companies cooperated in the 1990s with shipbuilders and heavy machine builders that developed machine systems for shipyards. To transfer innovation to another context is not a new idea. It was recognized at an early stage that the idea of a fixed site factory (see also 2.3) is not only highly relevant for the ship building industry or aircraft industry, but also for other on site building construction. One early example is the *Bauhelling* used by the constructing firm, Sommerfeld, in the late 1920s to construct a series of condominiums for Bauhaus director Walter Gropius (for more details see 1.5.2 and 5.2.7). The name of the construction system denotes that Sommerfeld has transferred idea and technologies from ship building industry. *Bau* is German for construction and *helling* for the site in a wharf where the ships will be assembled.

Innovation by Transformation: An established technique is transformed and adapted. Transformation goes beyond transfer and is aimed more at reinterpreting existing concepts with new technologies. In Japan, for example, it is common to first build the upper part of the building and start with the roof. Under the roof, the rest of the house is built on the ground level. For multi-storey buildings, each finished floor will be pushed upwards. Advantages are that the whole construction process is roofed and construction materials do not need to be lifted up to the upper floors; no crane is required. This traditional way of building a house in Japan has been transformed, refined and augmented by new technologies over time. For example Sekisui House with its J-Up System (see 5.2.5) and Kajima with the AMURAD for construction of high-rise buildings (see 5.2.4) refined and transformed that approach.

Another example for transformation is the application of the *shimbashira* principle in the Tokyo Sky Tree (Bock et al., 2011). Pagodas are multi-storey tower-like buildings, which can be found in Vietnam, China, Korea and Japan. As studies show, the *shimbashira* is a typical element of Japanese Pagodas facing regular earthquakes, but cannot be found in China or Korea, which are not, or at least not frequently, hit by earthquakes. In 2002, Center Column Vibration Control based on *shimbashira* technology was applied to the Marunouchi building, a 36 floor and 198 meter high building located near Tokyu Station. Another high-rise having adopted and transformed the *shimbashira* approach was built in Nagoya (Bock et al., 2011). The Tokyo Sky Tree is not an imitation of the pagoda's *shimbashira* principle, but a complex novel interpretation that has been combined with a multitude of state of the art techniques. In the case of the Sky Tree, active and computer controlled damping technology augments and refines the *shimbashira* principle. Another way to prevent structural damage as a result of earthquakes is decoupling the building from the ground. Decoupling systems interrupt vibrations of an earthquake by using so called "corner stones". Nowadays, decoupling systems are computer controlled and react with every wave of an earthquake. The whole building will be moved and steered against the earthquake's waves. This cutting-edge technology can set the oscillation amplitude of a building to almost zero (Bock et al., 2011).

Innovation by Overlay: This category refers to an overlay of new industry/manufacturing structures partly or fully on elements of existing structures. New innovations could also arise from designing a new production line manufactured with a consisting production plant. This consisting production plant often specifies the used material and influences the design of the developed product, as well as the existing technology and knowledge applied to it. For example, after the Second World War the aircraft production in Wichita stagnated, so the company had to look for another production line. Richard Buckminster designed the famous Wichita House which could be produced by the existing aircraft production plant of the Beech Aircraft Corporation. This Wichita House evokes the shape and material of airplanes of that time. The idea behind this futuristic type of house is the mobility and optimization of it. The user can therefore move easily with the whole house because of its modularity. Another production line envisioned was the Dymaxion Car which looks a bit like an aircraft cabin. This phenomenon can also be found in the Messerschmitt Company. Messerschmitt was a German aircraft manufacturer and after the Second World War started

after the with a new-designed car production line called Bubble and Cabin Cars. Another example of IbO is the Ōsanbashi Pier at the Port of Yokohama, located in Japan. The Ōsanbashi was constructed between 1889 and 1896. The architecture firm Foreign Office Architects designed the reconstruction to meet modern demands, which finished 2002. For this construction, shipyards were utilized and the whole building was built like a huge ship. The Company Shimizu Corporation executed the project but subcontracted the complex steel structure to be built by Kawasaki's automated shipyard (for further information on Kawasaki's ship-building technology, see **3.3.2**). As this reconstruction shows existing production structures in highly advanced and automated shipbuilding (rather than construction), we classify this example also as Innovation by an Overlay.

Innovation by Customer: The requirements of a building increase constantly. To identify problems and customer needs, several companies perform individual tests. The marketing research divisions of Sekisui House, Daiwa House, Sekisui Heim and Toyota Home generally investigate the customer acceptance of the solution space every six months. The results of these investigations are fed back into design development stage and continuously improve the products (for further details, see **3.2** and in particular **3.2.7**). Toyota Home, for example, focuses on designing smart houses and uses a modular system to construct these. This modular system is more adapted to customer needs and more flexible with its infill than regular houses. The Customization Culture *ringi seido* means that the decisions are non-hierarchical and informally made, so that information from customers and production are directly brought to the management and product design. To adapt more to the customer needs, it is also necessary to involve services. For older people especially, it is more and more important to customize inbuilt information platforms and networks by services like domestic aid or medical care. This also includes the integration of sensors for measuring vital signs or the connection to the computer and data platforms. This new service also requires new high-tech products to be able to act as a service channel – and high tech construction products require new ways of construction, which are linked to quality and precision production and assembly. In the following section (in our 7-DCI Diagram) we will clearly outline the interconnectivity of innovation dimensions.

7.2.3 Realizing Innovation in Construction by 7-Dimensional View

Based on the research in tools and views developed and used in innovation science in general (see **7.2.1**), and the analysis of the nature of innovation mechanisms in construction industry (see **7.2.2**), a comprehensive and construction specific view on innovation depicted by the 7-DCI Diagram (*Figure 7-3*) was developed (see also **Bock et al., 2012**). As mentioned previously, changes in various fields or levels (product, production process, logistics, business strategy, etc.) or innovations are often interconnected and are dependent on each other. Production technology can hardly be considered to be disconnected from materials, components, time, ecologic factors or product performance. In particular, this means, that production technology can cause, or force, change in all of those areas, and that, for example, a change to the material dimension or the ecologic dimension is linked to changes or innovations on the construction machinery/production

level. Thus, for a practically oriented innovation deployment in construction, we have defined 7-dimensions as follows:

- **Dimension 1: Construction Materials:** refers to innovations in, for example, the development of ultra-strength concrete. Such a development might be linked to other innovations such as robotic molding/material distribution and or a new design of components.
- **Dimension 2: Construction Machinery/Production Technology:** refers to incremental and disruptive innovations in the area of production technology used off-site or on-site. Improved robotic cranes or excavators might be seen as incremental short-term solutions. Includes the use of exoskeletons, humanoid robots and automated construction sites as more radical and long-term innovations (disruptive innovations).
- **Dimension 3: Construction Components:** This dimension refers to the modular structure of a building. There are various ways to modularize construction products. Furthermore, components delivered to the site can introduce a low added value (low degree of complexity, no installations, etc. included) or high added-value (high degree of complexity, equipped with finishing and installations. The development of three-dimensional units/space frames equipped with all finishing, installations and appliances is notably innovative. Those units are fully produced on the production line, for example, by Japanese companies as Sekisui Heim and Toyota Home.
- **Dimension 4: Construction Time:** This dimension refers to the time necessary for planning, set up of the site, construction and finishing. Changes to the set-up schedule or reductions of construction times are impossible to accomplish without changes to other dimensions. A very radical scheduling strategy (rapid construction) would necessitate radical solutions within almost all other levels.
- **Dimension 5: Construction Ecology:** This dimension refers to ecological factors related to the construction process itself or of the construction product. In Japan, major construction firms are currently deploying automated deconstruction sites, which allow them to reduce construction time and recycle nearly all building materials. This represents an example of innovation in this dimension, which is closely related to innovations in other dimensions.
- **Dimension 6: Construction Product Performance:** This dimension refers to innovations related to the construction products, in addition to the performance, or services related to those products. Our environments are becoming smarter, and increasingly more sensors and actuators are being embedded into our living environments, enhancing performance and serviceability. However, novel performance often demands also innovations, especially in the production and/or component dimension.
- **Dimension 7: Construction Management:** This dimension refers to innovation created at a managerial level. Management can often integrate innovations, while on the other hand it can be said that even small changes affect organization and thus the management dimension.

In addition to these seven dimensions of construction innovation, we have defined two key cross-section forces that can act within or across the described dimensions:

- **Force 1: Novelty Force:** This force refers to the novelty of a change to be introduced - routine innovation, improvement innovation, radical innovation.
- **Force 2: System-division Force:** In 7.2.1, the system viewpoint on innovation was introduced. The system-division force refers to this viewpoint, but it also allows the possibility of applying the notion of systems and subsystems to all seven dimensions.

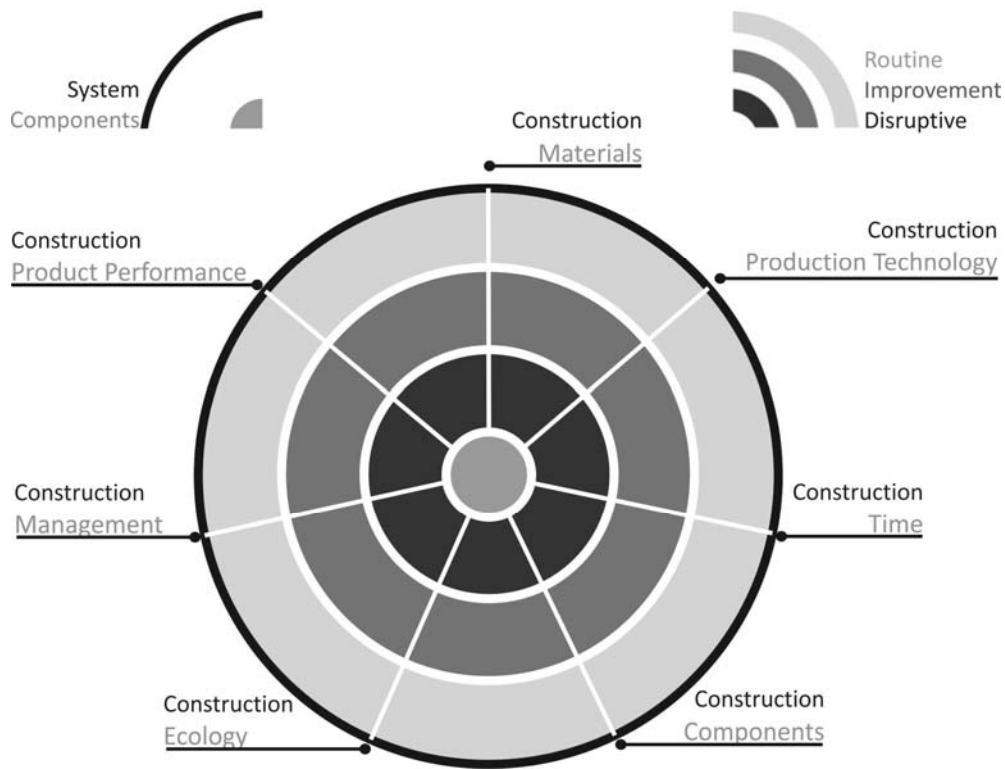

Figure 7-3: 7-DCI Diagram (Dimension Construction Innovation Diagram)

7.2.4 Augmentation of discussed Approaches (1-6) by advanced Technologies and Strategies

The approach presented in 6.1 in relation to real-time and building integrated manufacturing is a basic concept that was suggested on the basis of an analysis of the current state of automation in construction, and identified weaknesses. Below, strategies and technologies that would be compatible with the presented approaches, and which could be used to detail, improve or extend them are identified and explained concerning their relevance. In this chapter, suggestions are made as to how they could be used, specifically in light of the suggested approaches. ROD (discussed in detail in 6.2) principles could help to synchronize product design (building structure, modularization component design, connector design, etc.), manufacturing strategies and automation and robot technology. The application of the IbX classification system and the 7-DCI method could help to identify

the type of change necessary and thus the right strategies and tools. IbX and 7-DCI method are two different views on innovation mechanisms which do not exclude each other, but can be used in parallel to define and search in the innovation space. The tables below (*Table 7-1*, *Table 7-2* and *Table 7-3*) identify strategies/technologies relevant and explain their potential and possible application in relation to the approach discussed in **6.1**. In the IbX column a suggestion is made concerning which type of innovation mechanism can be used to develop the strategy or technology further in this context. Strategies and technologies set were introduced and analyzed concerning their relevance for automated/robotic construction in **chapter 2**. The 7-DCI column identifies the main dimension the strategy or technology can be assigned to. On the basis of these main dimensions, dimensions in which complementary changes or innovations are necessary can be identified. Basically, for each strategy or technology, identified changes at a system and/or component (see **7.2.1**) level can be intended depending on the innovation ratio (routine, improvement, disruptive, see **7.2.1**).

Strategy/Technology Field Modularity:

Table 7-1: Strategy/Technology Field Modularity. Identification of strategies and technologies compatible with the approach to real-time and building integrated manufacturing, detailing of their potential and identification of innovation and technology management methods that can be used to support their integration.

Strategy/Technology	Potential Related to Approaches Presented	IbX	7-DCI
Modularity in Development	Once a basic modular structure is applied to a building’s modularity, it could be used to systemically search for, or generate, innovations (e.g. through DSM, OES or the modular operators approach).	IbM	Management
Modularity in Building Manufacturing	The modular structure of the high-rise building to be constructed could be optimized to simplify manufacturing (e.g. by modularizing building blocks and super structure) or to allow for parallel production of building blocks, subsystems, etc.	IbM	Manufacturing
Modularity in Logistics	Considering the proposed construction speed, the supply to the site is likely to become the new bottleneck. The modular structure of the building, and thus the structure and size of units and girder elements, could be optimized to minimize logistical efforts from factories to the site and thus to guarantee a continuous supply of the site.	IbM, IbO	Time, Components

Modularity in Use	An open modular structure/standard could allow units to be delivered to the site from different unit providers and combined there (e.g. Units from Sekisui Heim and Cadolto). Assuming that different unit providers have expertise in different fields, this would enhance the options for the client.	IbM, IbC	Product Performance
Modularity for End-of-Life in Construction	The modular structure of the high-rise building can be designed to simplify deconstruction processes, reverse logistics, re-customization, or recycling. As with automated construction, the dissolving of connections between modules, and thus connector technology could play a major role in this context.	IbP	Ecology
Development of Platform Strategies in Construction	As stated earlier, platforms are able to reduce development complexity and cost. Superstructure and the integrated manufacturing technology (transportation loops, crabs, etc.) could be seen as a modular platform or distributed platform that could be applied, not only to high-rise buildings, but also to other types of buildings.	IbT	Management
Matching of Building Modules and Building Manufacturing Systems	Professional tools, Task Structure Matrix (TSM), Rank Order Classification (ROC) or Cluster Identification Algorithm (CIA) can be used to generate an optimized relation of building components, and manufacturing structure and technology.	IbPT	Production Technology
F&I Strategies in Construction	<p>Frame and infill strategies can be used to synchronize mass production and individualization demands.</p> <p>Building Level:</p> <p>Synchronization of mass production of frames (superstructure) with individualization by infill (units) as well as synchronization of elements with long life cycle (superstructure) with elements with shorter life cycle (units).</p> <p>Unit Level:</p> <p>Synchronization of mass production of the units' steel frames and their processing on a production line with individualization by infill (interior finishing,</p>	IbTT	Product Performance

	cabling, appliances, etc.) as well as synchronization of elements with long life cycle (units' steel frames) with elements with a shorter life cycle (interior finishing, cabling, appliances, etc.)		
Product-Service System Strategy	High-rise buildings could be seen by developers, architects and contractors as product service systems that are, once built, powerful platforms for continuously delivering life phase related services during its whole life cycle (maintenance, reconfiguration by integrated automation technology, re-customization of units).	IbC	Product Performance

Strategy/Technology Field Technology and Organization in Manufacturing:

Table 7-2: Strategy/Technology Filed Technology and Organization in Manufacturing. Identification of strategies and technologies compatible with the approach to real-time and building integrated manufacturing, detailing of their potential and identification of innovation and technology management methods that can be used to support their integration.

Strategy/Technology	Potential Related to Approaches Presented	IbX	7-DCI
TPS Principles in Construction	Application of TPS-principle of eliminating waste in the form of non-value creating activities and thus JIT and JIS operation. Operation of GF, TLs and GFFS continuously 24/7, without waste of time or down time through standstill or storage.	IbT	Manufacturing
Smart Principles in Construction	Extreme reduction of extent of added-value on-site equivalent to final assembly) in order to simplify manufacturing processes and reduce construction time on-site. Suppliers deliver to the site high-value-added, complex units and guarantee their fast and no rework necessitating installation.	IbT	Manufacturing
Introduction of Production- line-like Organization on-site and off-site	Production-line-like organisation is the most rigid organization in manufacturing. As the example of Sekisui Heim and Toyota Home shows it can also be used today to assemble highly customized units in the factory. The presented approaches try	IbTT	Manufacturing

	to link the on-site process chain directly to the factory output and to thus also organize it production-line-like. The result would be a closed production-line-like process chain spanning off-site factory and on-site factory.		
Demand oriented flexible Building Manufacturing	Manufacturing of units and components off-site can be fully demand oriented and thus pull-like. The installation of units in the GSSF by crabs can be seen as the final “pulling” station.	IbTT	Management
Factory and Process Layout Design (off-site and on-site)	The implementation of the above presented approaches would allow both off-site and ONM processes to be recorded and improved continuously on various levels (machine level, factory level, enterprise level, network level) by scientific tools.	IbPT	Management
Supply Chain Design for super-fast automated Construction Sites	Methods of supply chain design can be used to guarantee uninterrupted material flow between off-site entities, off-site entities and GF (GF). Additionally, the newly developed approach aiming at supplying and assembling building blocks by AVs (Daiwa Lease EDV-1) or UAVs (Aerial Construction ETH Zürich) could be integrated with the suggested approaches (e.g. direct delivery of heavy and specialized units, direct delivery or installation of girder elements. A new generation of airships (e.g. Lockheed Martin’s Cargo Transport Airship) could deliver manufacturing systems, units and girder elements to the site, thus preventing the construction from causing any burdensome traffic on the ground.	IbTT	Management
Introduction of OEM-like structure	As stated earlier, the introduction of an OEM-like supply and integration structure would be a key concept for realizing the above explained approaches.	IbO	Component
Changeability of off-site and ONM System	The creation of changeable and thus highly flexible manufacturing technology should already be considered in the early development stages of the new technology. GF, TLs, GSSF, STSF, and crabs can be designed as highly flexible manufacturing subsystems by means of modularity or in-built flexibility.	IbPT	Manufacturing

Allowance of diffusion of developed technology	Today, Shimzu uses subsystems of the SMART (e.g. logistics system, welding technology) as individual, non-integrated technologies on more-or-less conventional sites. In order to speed up the re-financing of the development application, scenarios for independent use of subsystems can be already developed and foreseen in early development stages.	IbO	Management
Stress environmental and social Dimensions	Use change to new building manufacturing technology resource efficiency and social aspects (health, safety, working conditions, employment structure).	IbC	Ecology
Real-Time Construction and instant Fulfilment	As stated earlier, the concept of RTE could be implemented through the suggested approaches, creating a construction system that would be capable of instant fulfilment of orders and thus to react more or less in real time (delay times below one month) on demand.	IbC	Time
Integration of decentralized and (desktop/personal) Manufacturing Technology	Decentralized manufacturing units can, through worldwide deployed communication networks and cheaper and cheaper logistics, be integrated into the supply chain for: The speeding up of delivery of components to unit manufacturers The manufacturing of highly specialized or highly customized parts, elements, components that will then be integrated by unit manufacturers off-site or by the GF The manufacturing of highly specialized or individual units by specialized unit manufacturers This system would allow the connecting of the existing crafts-based builders to the manufacturing network. As long as the BMU measurement system is accepted, individual providers could provide "handmade" units without affecting automated ONM negatively.	IbPT	Time
Mobile and Modular Mobile Field Factories	The Mobile Parts Hospital (MPH) approach, as well as the Mobile Field Factory (MFF) approach can create the starting position for the development of the GF. The GF could be set-up	IbPT, IbM	Production Technology

	up and disassembled rapidly, combining a multitude of MPGs or MFFs on-site to a full factory.		
Floating Factories (Mobile Naval BMU Manufacturing and Delivering Systems)	The oil and gas industry has already deployed networks of swimming factories (e.g. oil refineries etc.) in order to transform logistics periods to manufacturing periods. Similarly, unit manufacturing and delivery can be synchronized. Air craft carriers or large cargo vessels can be developed further or be reconfigured to Mobile Naval BMU Manufacturing and Delivering Systems that are informationally directly integrated into the GF (Linner et al., 2010). Manufacturing takes place under the flight deck. Delivery of units is possible via smaller transport ships and via helicopters or cargo airships.	IbO	Time

Strategy/Technology Field Automation and Robot Technology:

Table 7-3: Strategy/Technology Field Automation and Robot Technology. Identification of strategies and technologies compatible with the approach of real-time and building-integrated manufacturing, detailing their potential and identification of innovation and technology management methods that can be used to support their integration.

Strategy/Technology	Potential Related to Approaches Presented	IbX	7-DCI
Construction Robot Composition Strategies	Construction differs from manufacturing industries that produce only off-site (e.g. car industry, aircraft industry), in terms of component sizes, component weights and number of components. Besides the scale, the application location (on-site) is different. Similarly, as, for example, laboratory automation, clean room automation and automotive automation requires dedicated solutions, the construction industry would require the development of dedicated robot composition strategies.	IbTT	Manufacturing
Construction Robot Kinematics	The assembly process of components to units off-site as well as positioning, adjusting and fixation	IbTT	Manufacturing

	operations on-site (units girders) can be analyzed and transferred into a BMU related construction kinematic guideline.		
Sensor and Process Measuring Technology in Construction	<p>Research in construction specific sensor and process measuring technology has to be intensified. Sensor and process measuring technology can be developed for the following presented approaches:</p> <p>Sensor technology to guarantee accuracy of positioning and adjusting operations</p> <p>Sensor technology to support autonomous operation</p> <p>Sensor technology to support real-time-process monitoring</p>	IbT	Manufacturing
End-effector science in Construction	End-effectors are the direct physical link between the manufacturing system and the components to be processed. End-effectors conduct pick-up, positioning, adjusting and fixation operations. End-effectors have to be synchronized with components (size, material, weight, etc.), connector type (plug-and-play), robot configuration and operational sequences.	IbT	Manufacturing
Modularity of Automation and Robot Systems	Automation and Robot Systems off-site and on-site can be deigned to be modular and re-configurable to allow for changeability over time	IbC	Manufacturing
Tele-existence and Tele-control in Construction	Tele-existence and tele-control strategies and technologies can be used to supervise and control the complex supply chain, the JIT-delivery and installations of components on-site. A control center could supervise several automated construction sites and assign and control supply from floating factories, trucks and air vehicles. Along with the new building integrated manufacturing approach (Approach 6) tele-existence and tele-control could achieve rapid improvement of PME in construction.	IbT	Management
Robots for Human Power Amplification and Material Handling, Wearable Robot	Wherever human flexibility off-site or on-site is necessary, power amplification and material handling technology should support the human being (thus enhancing speed of work, quality of	IbT	Manufacturing

Technology	work and improving working conditions, safety and health).		
Android/Humanoid Robot Technology	Android and Humanoid robot technology could take over dangerous and specialized maintenance tasks (e.g. repair of facade defects at high altitudes) for which no specialized or building integrated technology exists.	IbT	Manufacturing
Social Robotics	Social Robot Technology could improve the efficiency of the interaction of site supervisors with each other or with the building integrated manufacturing technology (next generation of Human-Machine-Communication).	IbTT	Management
Open Source in Robotics	The current trend towards open source in robotics enhances the speed of innovation in the field and allows ONM systems to be put together by a multitude of subsystem solutions coming from different machines, software, sensor systems or robot technology manufacturers.	IbC	Components
Cellular Logistics	Cellular Logistics Systems could allow for the processing of units, and components, which, once delivered to the site's GF could proceed automatically and without human intervention. If autonomous vehicles were to be allowed for cargo transportation in the future, autonomous logistics to the site could be integrated with autonomous logistics on-site for a fully autonomous unit delivery and positioning system.	IbTT	Manufacturing
Self-Organization, Swarm Robotics, Singularity	If Approach 6 (building integrated construction and robot technology) were to be applied at city scale to a multitude of buildings, those buildings could be connected to each other informationally and logistically (via cellular logistic robots). The system could then automatically relocate deconstructed units in one building to locations in other buildings, or back to the factory for re-customization. The result would be a "robotic city" that could, following the principles of singularity, react flexibly and independently to change.	IbTT	Product Performance

In earlier chapters, the conceptual, technological, organisational and economical foundation for real-time and building-integrated automated construction was established. The success

of the next phase of R&D in the field of automated construction also depends on the ability to efficiently integrate existing strategies and concepts from other fields into the innovation and development process. Therefore, and in order to support the success of a future funding strategy intended to bring automating in construction to the area of economic feasibility, the methods and tools were identified, analyzed and suggested in this chapter that have the ability to influence the innovation process in terms of necessary time, resources and financial input. Other R&D fields and industries provide a rich ground of strategies and technologies that can simplify the innovation and development process related to the suggested approach. It has been shown in this chapter that the innovation sphere can be systematically searched, and relevant strategies can be identified (Table Column "Strategy/Technology"). Furthermore, those strategies can be analyzed concerning their potential for the suggested approach (Table Column "Potential related to approaches presented") and the innovation or development tools can be analysed, which would be necessary to make them usable (Table Column "IbX") and which field of innovation it can be allocated to (Table Column "7-DCI").

7.3 Reverse Innovation – Using the Construction Industry as an Incubator for Future Manufacturing Systems

In this chapter, it will be shown that not only the opening up of a novel markets in construction industry could be of interest for technology providers that think of advancing their business to the construction sector, but that concepts and technologies developed for, or within, construction technologies also hold the potential to be diffused into other manufacturing industries, in parallel or afterwards. As for construction, extremely flexible, cost effective and robust manufacturing systems are required that allow the automatic (final) assembly of highly complex products for individual purposes and customers. The construction industry could be used as a test bed for future manufacturing systems. The current void concerning manufacturing technology and the fierce requirements which automation and robot technology in the construction industry has to fulfill, also hold the potential to force novel approaches. Approaches related to automated/robotic construction discussed earlier in this thesis have already reached or can reach conceptual and technological levels which already exceed the current capabilities of comparable manufacturing systems or subsystems in other industries. For example, the capability of automated construction systems such as Shimzu's SMART or Obayashi's ABCS to automatically finally assemble (position, align and fix) the main structure of the building (columns, beams, floor slabs, facade elements) can be considered as more advanced than the current manufacturing technology in the ship industry, from which basic elements (e.g. from Kawasaki and Mitsubishi) for this technology originated. A combination of advanced approaches developed within construction industry can even be integrated into a comprehensive future manufacturing system for complex products, utilizing the potential of automation and robot technology throughout the life cycle of a product. As the construction industry currently fulfills the criteria of an underdeveloped market or industry, that would allow developing novel concepts and technologies and transferring them later on "uphill" to more advanced industries; the above outlined approach could be considered to be a type of reverse innovation.

7.3.1 Current Strategy of Automation and Robot Technology Providers

Despite the need for improvement and investment in the construction industry (low capital stock, defect cost, quality, low productivity, high resource consumption, etc.), companies from the automation and robotics industry see growing markets that allow them to develop and sell complex production/manufacturing technology currently featuring heavily in other, and technologically more advanced, industries. Thus, they focus on the final assembly technology for the aircraft-building industry and ship-building industry which have already achieved considerable levels of mechanization in final assembly and automation of upstream low-level component production processes (for further explanation, see **3.3**). According to the CEO of the aircraft technologies division of a leading German automation provider, the company will develop the new aircraft technologies division prior to a division for construction automation – despite the enormous and precise demand forecast for

aircrafts during the next 15 years- as the standardization/modularization of aircrafts and the already reached technological state in aircraft manufacturing industry allows them to transfer a multitude of concepts and technologies from the automotive division of Dürr AG (**Siewert, 2012**). Similarly, despite the fact that the number of industrial robots sold per year has been stagnating since 2005 (**see 2.4**) and the possibility to develop technology for the construction field, which is situated between the industrial robot and service robot field (**see 2.4**), major robot manufacturers such as Kuka or Yasukawa/Motoman, are still developing new technologies and robot concepts with a focus on the automotive industry. Kuka, for example, is bringing its highly flexible and human-cooperative lightweight robot to the marketability stage by using the application in the final assembly line in the automotive industry as the main application scenario. The technology will be developed to meet the requirements in this industry, and then adjusted for the use in other industries or for use by SMEs (for further information, **see 2.4**).

Thus, in order to minimize risks, and to shorten necessary investment in knowledge and technology build-up, the automation and robot technology industry follows the conventional path of incremental innovation, and develops technologies for the already advanced industries, which it then later considers adapting for other industries, which are less advanced, or which would be in tougher markets with less resources available. However, with this approach, companies underestimate the potential of the construction industry for their businesses. Besides the above mentioned need in the construction industry for radical improvement, the favorable characteristics of the construction automation market mean that it is an industry ripe for highly advanced technology (situated between the industrial robot market and the service robot market). Novel approaches for the deployment of automated/robotics to off- and on-site factories combines OEM-like integration structures, real time and building integrated manufacturing and associated R&D and funding strategies, which have been introduced and discussed in this thesis. It has been shown that the organizational and technological basis has been laid through developments starting as early as in the 1980s.

One aspect, which has not yet been discussed, is the fact that the overcoming of challenges in the manufacturing of highly complex products in the building industry would be able to generate future manufacturing systems for highly flexible and resource efficient production that will in the near future be demanded in a multitude of industries (**see Piller, 2006; Lindemann et al., 2006, Reichwald & Piller, 2009, Pine & Gilmore, 1999; Fujimoto, 1999**). Furthermore, due to the current lack of specialized machine technology, automation and robot systems for the construction site (discussed in detail in **1.5**) where in Europe, as well as in Asia and USA most of the value creating and material transforming operations is conducted, the construction sector for high-tech industries is a market waiting to be explored, that would, once developed and opened, create enormous demand. In this chapter it will be shown that the creation of a demand and a novel market in the construction industry could not only be of interest for technology providers, but that the developed concepts and technologies potentially also be diffused into other manufacturing industries in parallel. Current research, technology development strategies and funding initiatives (for example **AUTONOMIK, 2012**) show that the general manufacturing industry is

seeking novel solutions that allow for the highly autonomous and robot-based production and assembly of complex products at best in one-size batches.

7.3.2 The Idea of Reverse Innovation

As stated by Govindarajan & Trimble (2012), reverse innovation refers to innovations (technologies, concepts, processes, organizational forms, etc.) that are developed firstly for developing markets (for example India, Mexico, Brazil, etc.) with the aim of transferring those technology later on “uphill” to more developed markets. The concept implies that solutions for developing markets have to be generated under fierce conditions (for example less available resources for novel development, e.g. less material needed to produce it, low-cost, simple to manufacture) as solutions with maximum performance (highly applicable and locally adapted, highly efficient tradeoff between inputs and product performance) thus necessitating and forcing novel solutions that are of a high interest to developed markets, where competition and rising user demands also necessitate more and more highly efficient and, at the same time, cost effective solutions. As described above, from the perspective of automation and robot technology providers, and in relation to other more “developed” industries such as present in the automotive, aircraft or shipbuilding industries, the construction industry can also be seen as an underdeveloped or developing industry (see also 1.2, 1.4, 1.5, 2.4 and 3.3.6). The conditions in the construction industry under which innovation will be created are also fierce (low R&D spending, low investment rate concerning machine technology, reluctance to change) but high performance solutions have to be found (e.g. with the manufacturing of complex and highly individual products at high quality and at low cost, solutions will have a positive impact on the reduction of energy and resources). Efficient and cost-effective concepts, and technologies that allow mass customization of complex products, to re-customize and remanufacture complex products in a systemic and industrialized manner, to deploy robot technology that can interact with human beings in highly flexible production settings and at the same time keep the products in an affordable segment are subject to growing discussion in a multitude of industries.

The manufacturing of complex and individual products, such as buildings on the production line in an OPF manner to nearly the same cost (or at least only slightly higher costs) as perfected by Japanese LSP companies, is a unique manufacturing capability generated solely to match the individual requirements in the generally underdeveloped construction industry. Before the building is produced, the buildings are planned together with the customer in an off-line configuration process according to a systemic analysis of the customer’s demands on the basis of a variety of “platform” or basic types (for further information, see 3.2.7). Furthermore, as stated earlier (see 3.2), and as outlined in detail in Linner & Bock (2012), Japanese LSP companies not only bundle but integrate life-cycle related services (e.g. renovation and upgrade) services over the modular structure to their products and thus gain a relationship with customers and acquire knowledge about them over the life-cycle of a building, allowing them to continuously improve their products and businesses. Japanese companies have thus realized and perfected concepts that can currently be seen as farfetched to be deployed, for example in the automotive industry

where (still unequal) customer-producer relations are currently only deployed in the high end market (e.g. Audi R8 Exclusive Customization Option) or in the luxury segment (e.g. Rolls-Royce).

As interpreted by the concept of reverse innovation, the challenge of developing automated/robotic manufacturing technology for the currently underdeveloped construction industry under fierce conditions could be seen as a chance for manufacturing industry in general. Once it is possible to, for example, customize complex products such as buildings (that can require even more parts and components to be joined than for the completion of a car (discussed in detail in **3.3.5**), manufacture them off-site (see **3.2**) and on-site (see **5.2**, and **6.1** in particular) in a production-line-like and OPF manner, integrate life time services or upgrade, re-customize or fully disassemble/ recycle them in a systemic and industrialized manner (see **5.3**, and **6.1.13** in particular), the learned concepts and technologies could pioneer novel manufacturing strategies that would be advantageous and enhance competitiveness in non-construction industries as well.

7.3.3 Advanced Approaches to be Re-transferred from Automated Off/On-Site Construction

It will now be shown that approaches related to automated/robotic construction discussed in this thesis have already reached or can reach conceptually and technological levels, exceeding the capabilities of comparable manufacturing systems or subsystems in other industries. Manufacturing sub-strategies or subsystems developed for, or within the construction industry, such as advanced customer integration strategies, production-line-based OPF for industrialized customization, automated fixed-site/on-site assembly factories for large-sized complex products, building integrated automation/robot systems and “smart” components, and Closed Loop Manufacturing Strategies pioneer manufacturing subsystems which are demanded by, discussed or under development in other industries with complex products as well. In the next section it will then be shown that those advanced manufacturing subsystems discussed in this can be integrated to a comprehensive future manufacturing system for complex products in general, utilizing the potential of automation and robot technology throughout the whole life cycle of a product.

1. Advanced customer integration: A specialty of the Japanese LSP companies is the almost perfected integration of the customer in the design process and the product improvement process. The configuration process is done by all companies in several steps, guided by trained customer contact staff helping the customers to make decisions as quick as possible. The complex configuration software allowing the choosing of types and variants, and enabling adjustment of finishing and details according to individual needs is used by the service staff. Configurators are specially developed by data-model-oriented CAD programs with extended functionalities. Once an individual design is fixed, the programs automatically generate parts lists and coordinate tasks, logistics and fabrication processes (e.g. Sekisui Heim’s Automated Parts Pickup System). Japanese LSP companies allow their customers to individually

select their preferred degree of customer integration. Yet the degree of customer integration (still) determines the price. If the customer defers to one of the basic types, chooses a standard floor plan and standard finishing for interior, windows and facade elements, the price for the house will be at a minimum. However, it is up to the customer. Both companies are able to prefabricate houses with specific floor plans, special shapes, customer determined or even customer designed individual finishing. Customers are invited for experiments and “test living” in the companies’ R&D centers. On the basis of scientific data about the user and his living habits, the company then generates the building’s layout and functions. Furthermore, the previously discussed *ringi seido* culture (for further details, see **1.1**, and **7.2.2** in particular) plays a role which refers to non-hierarchical and informal decision-making, bringing information from customers and production directly to management and product design, thus generating important feedback loops (for further details, see **3.2** and also **7.2.2**). The building manufacturers gradually try enhancing the degree to which customers are involved in production and development issues. Japanese LSP companies have perfected the notion of customer co-creation. More than 90% of the information about the co-created products can be transferred by the ERP systems directly into production information (work schedules, logistics sequences, machine operation, and work-task manuals). The information about the customer, gained through customization, is used to deepen the relation with the customer and to improve the products over time.

- 2. Production-line-based OPF for industrialized customization:** Sekisui Heim, Toyota Home and Misawa Home apply a F&I strategy organized around three-dimensional steel space frames (the frame) and most other companies on the basis of (two-dimensional) steel or wood frames (e.g. Sekisui House, Daiwa House). The frames allow mass production effects and can be outfitted individually on a final assembly line. Different subsystems and sub-components (infill) are supplied by a network of n-Tier suppliers on demand and integrated with the (mass produced) steel frame structure in the factory JIT and JIS. Companies use, for example, their steel frames (e.g. Sekisui House) or steel space frames (units, e.g. Sekisui Heim) as an adjustable platform on which all different types of buildings and their individualized descendants are built upon. It is the common basis for all types and variants allowing stable production processes, despite the ability to customize houses to any need (discussed previously in **3.2.2**, **3.2.3** and **3.2.4**). Sekisui Heim, Toyota Home and Misawa Home in each of their factories assemble their prefabricated units on one single production line.

Each unit on the production line depends on the individual floor plan of each building and the individual interior/exterior design applied is different. Additionally, each unit is a complex and individual mixture of platform/frame parts, standardized customer individual parts and completely individually designed parts. Through the strong integration of suppliers, individual designed parts and components (e.g. bath modules) can be produced and delivered by suppliers. The companies with OPF methods have perfected and pioneered a concept which becomes of growing interest for the automotive industry. It equals, from the perspective of a manufacturing organization and technology, the manufacturing of the VW-Phaeton (see **2.3**). The VW Phaeton is a luxury

car with a high degree of customization, and the configuration of each car on the conveyor belt varies more than in any other car series. VW, therefore, on the production line, uses no robots for positioning or assembly but fully exploits the flexibility of the human workers. VW foregoes efficiency by hiding automation. While all assembly processes are manual, the logistics of parts and components to the production line and the workers is fully automated.

The component storage racks between the cars contain all the parts and are continuously exchanged by AGVs that can couple into the racks. The exchange takes place JIT and once one rack is nearly empty, another one with parts for the next processes is already waiting beside the conveyor for the exchange. At about €80,000-100,000, the Phaeton is relatively cheap for a “handmade” luxury car. However, it is still a very high-end, or luxury car, and the Phaeton cannot be customized at the same price level as a standard VW car. Indeed, it costs 200-300% more than a standard VW. On the contrary, Japanese LSP companies allow even more individualized products (at least in basic versions) to be produced at nearly the same, or at only a slightly higher cost) as conventional buildings (depending on the customer’s wishes, up to a maximum of 50% more. The basis for this ability is the automation of low-level component production in combination with a perfected and highly flexible OPF organization, alongside a single production line. Enterprise Resource Planning (ERP) systems for controlling the production and logistic flow were introduced and refined for that purpose in the 1970s. All in all it can be said that the Japanese LSP industry meets the requirements of real and affordable MC (Piller, 2006), more or better than the automotive industry. Both Sekisui Heim and Toyota Home have advanced the concept of the TPS that they adopted in the 1980s (for further information, see 2.3 and 3.2) to a demand oriented manufacturing system that exceeds by far the current ability to mass customize in automotive manufacturing.

- 3. Automated fixed-site/on-site assembly factories for large, complex products:** In chapter 4 and 5, the possibility to deploy temporary and highly flexible on-site factories was discussed. In chapter 5 it was discussed that advanced forms of such on-site factories can under certain conditions (e.g. organizational conditions) be used to construct buildings in a near real-time manner. Through inbuilt flexibility (workspace and re-programmability of OMs, exchangeability of end-effectors) and modular flexibility (e.g. exchanging or adding of subsystems) such factories can be adapted within a certain scope (mostly a building typology) to a variety of different designs. Within those on-site factories, manipulators position, align and in some cases even fix the main structural components of the building almost automatically.

The capability of those on-site factories exceeds the current practice in ship manufacturing or aircraft manufacturing where components (e.g. fuselage main body assembly) are positioned and aligned (assisted by fixtures, overhead cranes and other handling tools) in a manual and work-shop like manner. Even in the fuselage assembly of the A320 in Hamburg Finkenwerder (Airbus), which is in the aircraft manufacturing field, is considered to be one of the most advanced manufacturing systems worldwide,

the level of automation has not yet been achieved. Russian aircraft manufacturers are currently developing the world's first automatic fuselage body panel positioning system at a research level (Siewert, 2012). Although, Japanese ship manufacturers in the 1990s contributed to the development of the first wave of on-site factories with knowledge and technologies (e.g. overhead crane systems technology, welding technology, end-effector technology), conceptually, the capability of automated construction systems such as Shimzu's SMART or Obayashi's ABCS to automatically undertake the final assembly (position, align and fix) the main structure of the building (columns, beams, floor slabs, facade elements), can be considered as more advanced than the current manufacturing technology in ship industry.

Furthermore, as stated in **chapter 6.1**, those technologies can be advanced organizationally and technologically into the next level, and strategies from the field of ROD (see **6.2**) can be used to reduce, on the one hand, cost and complexity, and guarantee robustness on the other hand. From that point of view the advance of on-site factories as discussed previously in this thesis would create a manufacturing technology that would be of high interest for companies in other fields, manufacturing large-sized and complex products in a fixed-site manner (e.g. Airbus A380, Boeing Dreamliner, complex ships for oil and gas mining industry, passenger/cruise ships).

4. Building integrated automation/robot systems and “intelligent” components: In **chapter 4.1** and later on in **6.2.2** it was shown that STCRs for facade installation, facade painting and facade maintenance (see **4.1.10**, **4.1.12** and **4.1.15**), such as over-facade integrated rail systems (e.g. Taisei's rail guided facade painting and inspection robot) could be fully integrated within the building and attached to the building as a permanent robotic system, which during the life-cycle, was reactivated for facade inspection and facade re-painting tasks. Furthermore, in this chapter it was shown that STCR technology was developed for a multitude of service and maintenance tasks. The technical analysis of on-site factories (see **5.2** and **5.3**) showed that some systems have already made use of the integration of subsystems after on-site assembly into the building. For example, ABCS (Obayashi), SMART, T-Up and Roof-Robo (for further information on Automated/Robotic On-site Factories deployed so far, see **chapter 5**) utilized the steel structure of the uppermost floor as the SF base element, to which covers, working platforms, climbing mechanism and OMs were mounted. With this approach, set-up times are minimized and cost of the manufacturing system are reduced and transferred over the building's structural cost. The deconstruction approach of Taisei's TECOREP which utilizes the uppermost floor/floors of a building as an SF roof structure, shows that SFs integrated into a building right after completion can be reactivated later on, for deconstruction purposes, for example (for further details Automated/Robotic On-site Factories for deconstruction, see **5.3.1**).

In chapters **6.1**, and **6.1.13** in particular, it was shown that future ONM systems can go a step further by fully integrating the SF and subsystems (e.g. crabs) into the building and utilizing those systems for continuous re-configuration of a building during its life cycle. This approach would allow that the manufacturing system to be seen as a kind of

building technology, allowing for the distribution of the cost for the manufacturing technology over the building structure and building technology, to a certain extent. Furthermore, it was discussed in **chapter 6.1.10** and later in more detail in **chapter 6.2.5** that according to ROD principles, sensor and measuring technology necessary to position and align components in the on-site factory could effectively be transferred to and embedded into the component itself, becoming a smart or intelligent component. Such smart components (“smart” used in the sense of integrated with electronics, actuators, sensors, control systems, etc.) can be re-activated and used during the life cycle of the building, for example, for measuring misalignments or damage (e.g. after earthquakes) or to provide the integrated robot systems with information on the component for building-rearrangement or building-deconstruction purposes. As discussed before, the embedded sensors and control hardware can be designed for dual use; such as positioning and alignment guidance, and as part of the building automation system.

The integration of robot systems into the products that can be used for continuous inspection and maintenance during the life cycle would be of interest for other products which have either a very long life cycle and are difficult to access (e.g. large tunnels or bridges) or which are inspection and maintenance intensive (e.g. aircrafts and ships). Complete on-site factories that stay on-site would also be interesting for the oil and gas industry which are requesting more and more flexibility in the provision of its equipment (e.g. Samsung Heavy Industries) – rearrangeable and deconstructable deep sea or arctic drilling stations, for example. Furthermore smart components could be of interest for any industry that manufactures complex products with a high rate of integrated electronics, and which is thinking of automating its final assembly (e.g. passenger aircraft fuselage body panel assembly).

5. Closed Loop Manufacturing Strategies – “zero-waste” factories, re-customization, deconstruction/urban-mining: Manufacturing systems can be designed to efficiently meet environmental and social issues. The paradigm of sustainability is gradually pervading all industrial sectors, all levels of value creation and all aspects of daily life, leading to a novel 21st century industrial revolution, where the importance of environmental and social factors are finally becoming equipollent to plain economic efficiency. Legal frameworks, financial incentives and market/price developments are urging more and more industries to change their processes and to shift from economic growth to sustainable development. Besides a change in organization, novel process technologies, microelectronic devices, ICT, flexible automation, robotics and knowledge based logistics are at the heart of that revolution. Technologies and concepts from the construction industry that were introduced and discussed in this thesis could pioneer novel and sustainable manufacturing strategies:

- **“zero-waste” factories:** Manufacturing systems can be designed to efficiently meet environmental and social issues. The paradigm of sustainability gradually pervades all industrial sectors, all levels of value creation and all aspects of daily life, leading to a novel 21st century industrial revolution where the importance of

environmental and social factors finally becomes equipollent to plain economic efficiency. Sekisui Heim and Toyota Home – major Japanese LSP companies - show that industrialized and highly automated factory production of buildings can address multiple sustainability aspects. Resource consumption is reduced through demand oriented manufacturing, structured factory environments, closed loop recycling, and energy-harvesting within manufacturing systems. Both have already set up zero-waste factories. On the one hand, this was achieved with the supply of parts, components and modules fitting into the product structure without further processing or cut-off waste, as discussed in the previous section. On the other hand, the target of zero wastage was achieved by the fastidious sorting of material waste for reuse and recycling. In the automotive industry it is already common (e.g. Audi) that cut-off waste generated during stamping of aluminum body panes is sent back to the supplier where it can be 100% recycled and reused for new aluminum sheets. Furthermore, in factories themselves, color particles during painting and water used in the factory are recycled and reused within the factory’s closed loop. Similarly, Japanese companies producing buildings in controlled and structured factory environments sort waste fastidiously into different categories to prepare it for fast and, if possible, closed loop recycling.

- **Re-Customization:** All obsolete building modules of Sekisui Heim (see also 3.2) can be accepted as trade-in values for a new Sekisui Heim building. Therefore, the deconstruction process is a reversed and modified version of a construction process, being based on subsequent unit factory completion of modular units on the conveyor belt, as previously described. For deconstruction, first joints between steel frame units are eased, and then the house is transported to a special dismantling factory, unit by unit. There, the outdated finishes are dismantled and fed into advanced reuse cycles established around factories. The bare steel frame units are further inspected and renovated, and then equipped with new finishes desired by a customer who has chosen to buy a remanufactured house. On a web platform for “Reuse System Houses” (Sekisui Heim, website), Sekisui organizes a matching of people who want to sell their modular house for reuse and people willing to buy a remanufactured home. The newly outfitted units are then assembled on a new foundation in a new site. Thus the system allows for a house, once purchased by parents or grandparents, to be relocated and reorganized to serve children or grandchildren. For remanufactured homes, Sekisui Heim offers the same guarantees, supports and services as for newly built houses.
- **Urban Mining:** Urban Mining refers to strategies that allowing the city, and especially its building stock, as a mine for resources, parts and components. Systemized deconstruction of buildings under controlled and structured conditions, as in automated construction sites, plays a crucial role in urban mining. In Japan – where the deposit of materials is costly – major contractors, such as Kajima, Takenaka and Taisei, have therefor, developed reversed versions of their automated construction sites that allow that parts and components to be disassembled in a way that allows fast and simplified recycling, down-cycling, remanufacturing or re-use (see 5.3 for details). In 2008, Kajima, for the first time, deconstructed a semi-

automated deconstruction system of three high-rise buildings in the center of Tokyo. The process of deconstruction was a reversed and re-engineered version of the construction process, executed by its automated Construction System AMURAD. It starts with the dismantling of the ground floor. Meanwhile, dismantling the ground floor, the upper part of the building was held by IT-coordinated hydraulics. With this method, each floor was dropped down one-at-a-time and subsequently disassembled at the ground floor level. As the deconstruction was thus highly coordinated and could conveniently be conducted on the ground floor level, 93% of the building components could be recycled (recycling rate of conventional demolition: 55%, see for example **Bock, 2009**; see also **5.3**).

Systems for avoiding waste and the reduction of resource consumption, reverse logistics, remanufacturing and recycling, as discussed in this section, could be closely linked to creating closed-loop manufacturing structures for sustainable resource, material and component circulation. The creation of closed loops could be related to manufacturing systems concerning various scales or product phases during the life cycle of a product. *Figure 7-5* shows in an abstract and simplified way how material or product flows at a factory level (BCM, LSP, and Automated/Robotic On-site Factories), utilization level and deconstruction level could be related back to the manufacturing system in order to close the loop. Product related issues of disassembly/re-manufacturing, as well as more detailed classification of disassembly/re-manufacturing strategies were outlined analyzed and discussed more detailed in **2.2**, and in **6.2.1** in particular.

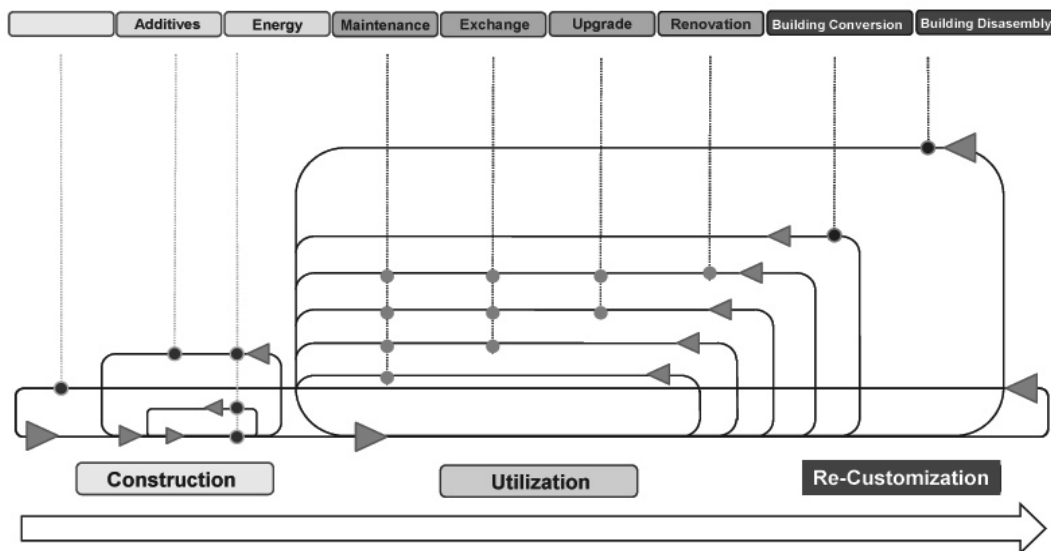

Figure 7-4: Closed Loop Manufacturing: material or product flows at a factory level (BCM, LSP, and Automated/Robotic On-site Factories), utilization level and deconstruction level could be related back to the manufacturing system in order to close the loop. (Adapted and advanced on basis of **Steinhilper, 2007**).

7.4 Conclusion: Concept of Life-cycle Integrated Manufacturing Technology

As stated in the introduction the main goal of this thesis was to search for ONM technology. In the thesis it has been shown that besides ONM technology, complementary and closely linked OFM technology (upstream by suppliers) and manufacturing technology that allow the maintenance, change, customization and deconstruction of buildings (e.g. building integrated as proposed **and discussed in detail in 6.1**) are solutions that can be advanced instantly on the basis of already existing technologies. The construction industry is thus able to pioneer the integration of manufacturing technology to unfold the potential of CIM, advanced product structures and advanced organizational concepts (as discussed in the introduction of this thesis) over the life cycle of a product. Throughout the thesis, five automation and robot technology based manufacturing technologies (“M”) have been identified and discussed. Their advance and integration to a manufacturing system for real-time and building integrated manufacturing of high-rise buildings was discussed in particular in **chapter 6**.

- **M 1:** OPF (e.g. Japanese unit based LSP Industry, Sekisui Heim, Toyota Home, Misawa Hybrid)
- **M 2:** Automated final assembly by on-site factories (focal point of this thesis, Chapters 4 & 5)
- **M 3:** Building-integrated robots for inspection, maintenance and change (as discussed in relation to STCRs and within Chapter 5, for example)
- **M 4:** Production-line-based Re-customization (e.g. Japanese unit based LSP Industry, Sekisui Heim)
- **M 5:** Automated deconstruction for urban mining (discussed within chapter 4 & 5)

In this chapter the manufacturing concept can be generalized into a comprehensive framework that can be depicted as follows:

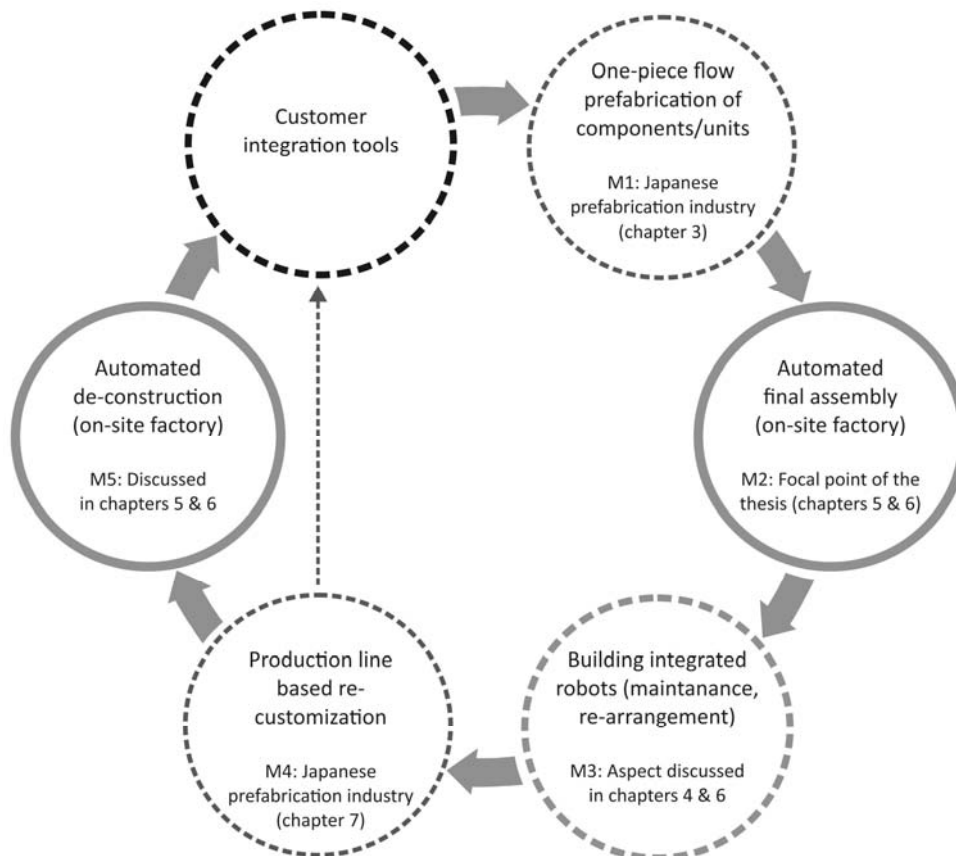

Figure 7-5: Framework for the integration of automation and robot based manufacturing technology over the life cycle of buildings

The above outlined comprehensive framework for the integration of automation and robot based manufacturing technology over the whole life cycle of buildings (*Figure 7-5*) could be advantageous also for non-construction industries. As in many developed countries in Asia (e.g. Japan), as well as in European countries, due to globalization and urbanization, products as cars or buildings are about to lose their meaning as predominant status symbols (especially within the younger generation), the following industries generating products with growing importance could learn from the above described concepts pioneered in the construction industry:

- Mass-customized clothes
- Mass-customized bikes and e-bikes
- Mass-customized Furniture
- Mass-customized computers, tablets and mobile phones

Furthermore, industries manufacturing highly complex products could learn from the above described concepts pioneered in the construction industry:

- Mass-customized cars
- Mass-customized business jets and other aircraft
- Mass-customized ships (complex segment: ships for oil- and gas industry, cruise ships)
- Mass-customized infrastructure (roads, bridges, tunnels)

As shown above, in the construction industry automation and robotics based manufacturing strategies are not only able to produce highly complex products in a near real time manner, but are able to support and build up close relationships with customers and to use manufacturing technology to maintain (see **4.1.12** and **4.1.15**), re-customize (see **3.2** and also **6.1.13** and **7.3.3**) or deconstruct (see **5.3** and **6.1.13**) the product. Automation and robotics based manufacturing can be integrated within the building throughout the whole life cycle of a building (see **6.2.9** and **6.2.10**). Strategies developed within construction industry would thus not only enable the industrialized and cost-effective production of customized products but also address the switch to whole life cycle related service approaches and upcoming issues related to re-manufacturing and consumption of resources. The growing need for service and product-service-system approaches and related design and manufacturing strategies in multiple industries is discussed for example by **Sakao & Lindahl (2009)** and was mentioned earlier in this thesis in **chapter 2**. Issues related to re-manufacturing and consumption of resources in non-construction industries were earlier discussed already in detail in **6.2.1**. It was shown that companies as Xerox (Equipment returned to Xerox can be remanufactured into new copiers reusing 70 to 90 %), Boeing (Boeing's latest military helicopter AH-64D Apache Longbow Block III Combat Helicopter is remanufactured on basis of major components as the chassis of older AH-64D models) and Audi (Audi wants to remanufacture parts/components of cars) already have or about to implement such strategies. The above described comprehensive framework for the integration of automation and robot technology over the whole life cycle not only focuses on one manufacturing aspect (e.g. solely customization or solely resource efficiency) but the integration of multiple manufacturing aspects over the whole life cycle of a product.

The construction industry as a market that requires cost-effective, simple and highly effective solutions for highly individualized products could serve as test bed ("incubator") for future concepts and technologies in the manufacturing field. The currently construction oriented product structuring framework ROD could be advanced and adapted and serve also non-construction for the development of cost-effective and robots automation and robot based manufacturing technology for all product life cycle phases. Although reverse innovation alone might not be able to provide the incentives necessary for investment and technological development in the construction industry, it complements the approaches formulated in former chapters (modular and flexible on-site factories, real-time and building integrated manufacturing, complexity reduction through ROD, roadmap to economic feasibility, R&D and funding strategy) in forming a comprehensive technology creation strategy. The consideration of a reverse innovation strategy already in the phase of convectional development of a manufacturing technology for the construction industry as suggested in this thesis, can ensure that development costs can, later on, actually be distributed over several industrial sectors or manufacturing fields.

8 Conclusion, Future Research

In order to find answers to the search for a novel ONM technology, and in order to be able to discuss the hypotheses (see 1.6), related terms and concepts were introduced and analyzed (see chapter 2), the development in off-site BCM and LSP as well in other industries manufacturing complex products were mapped (see chapter 3) and existing approaches to STCRs (see chapter 4) and Automated/Robotic On-site factories (see chapter 5) have been systematically mapped, and analyzed qualitatively and quantitatively. Furthermore, based on the identification of strengths and weaknesses of the analyzed approaches (see 5.5), in an exploratory study, novel possibilities for the deployment of on-site factory environments were tested (see chapter 6). Based on the analysis, categorization and explanatory study, the principles for ROD have been taken forward, and methods and approaches have been suggested for an R&D strategy that would allow the realization of the suggested manufacturing technology (see chapter 7).

The discussion of hypotheses throughout the thesis can be summarized as follows:

1. **Systems outperform stand-alone technological solutions:** It was shown that the overemphasizing of the human factor in conventional construction (see 2.1), the lack of integration of all construction activity by OFM technology (see 3.1 and 3.2) as well as the integration of STCRs into the on-site construction process (see 4.1) prevents optimized and chain-like manufacturing systems in construction. It was shown that industries such as tunneling, shipbuilding and aircraft construction, which also manufacture and customize complex products, successfully systemized the final assembly process by fixed-site/on-site factory environments backed by OEM-like integration structures (see 3.3). On that basis, an optimized material flow is possible in a JIT, JIS manner. The Automated/Robotic On-site Factory approach implemented from the 1990s onwards (and analyzed in this thesis using 30 case studies) was able to provide a basis for the integration of automated robotic systems and other means of production within a SE to a factory-like setting (see chapter 5). The analysis of the evolution scheme, section ground plan and the manufacturing process showed that the factory layouts and the optimization of the material flow from material delivery to the site to the installation in a JIT and JIS like manner were a recurring theme (see 5.2 and 5.3). Although some systems worked with temporary on-site warehouse modules, or ground-based component processing yards (for example Akatuki 21, AMURAD, T-Up) a major focus was on optimizing factory layouts in order to erase the necessity of storage, and allow a direct pick-up link between pick-up from the delivery truck and assembly operations (for example Roof-Robo, BAM, System Skanska) and if possible, even parallelized pick-up-assembly operations (for example SMART). However, it was also shown that in order to achieve efficiency levels comparable to other industries (for further information about efficiency deficits, see 5.4 and 5.5) the arrangement and interconnection of

subsystems, the integration with OFM, and material flow must be optimized further (see 6.1).

2. **Automated/Robotic On-site Factories can be developed for manufacturing any building typology:** The analysis conducted within **chapter 5** identified and analyzed all approaches to Automated/Robotic On-site Factories that have been conducted so far. Considering the analyzed systems and the fact that some of the systems were used several times (for example ABCS and SMART each up to ten times), that subsystem applications are frequently used (e.g. Obayashi) and that currently the application of the on-site factory approach for deconstruction is taking off in Japan, it can be said that the Automated/Robotic On-site Factory approach to date has been applied more than 60 times worldwide. On the basis of the technical analysis conducted, categorization into 13 categories shows that Automated/Robotic On-site Factories can be installed at various locations on the construction site (on the ground, on top of buildings) and can progress in various directions (for example vertically or horizontally) thus allowing solutions for almost any building typology (for example various high-rise building typologies, condominiums, point-block buildings, steel buildings, concrete buildings (see 5.2.1 to 5.2.10 as well as summaries in the *Analysis and Categorization Matrix*). Besides construction purposes, the on-site factory approach can also be used to deconstruct buildings of different typologies (see 5.3.1 to 5.3.3). This means that from a technical point of view, that Automated/Robotic On-site Factories based on the applied and analyzed technologies (subsystems, end-effectors, factory layouts) hold the potential to be developed for manufacturing any vertically or horizontally oriented building typology.
3. **Automated/Robotic On-site Factories can mass customize buildings:** The systemic analysis of subsystems and end-effector technology in **chapter 5** showed that Automated/Robotic On-site Factories were in most cases developed as modular kits which allowed, through a combination of in-built flexibility and modular flexibility, high variability. Each system could be broken down into multiple subsystems (see analysis of subsystems for each system in 5.2 and 5.3). Systems that work beside a main factory (e.g. SF) with a sub-factory (ground-factory) are comprised of up to 12 subsystems. Simpler systems such as the *Bauhelling* are comprised of only about four subsystems. On average, systems with only one main sky or GF are comprised of about eight subsystems. Subsystems that can be found in some form in any system are a type of factory cover, a climbing, sliding or push-up system and vertical and/or HDSs. Concerning the end-effectors, two different major strategies could be identified (see analysis of end-effectors for each system in 5.2 and 5.3). Either end-effectors are designed to be multipurpose with inbuilt flexibility or are exchangeable/modular. In the case of the modular approach, up to eight end-effectors could be identified for an individual system (ABCS). Like advanced manufacturing environments in the general manufacturing industry, Automated/Robotic On-site Factories, generally speaking, were developed as sets of re-combinable subsystems with in-built (robotic) flexibility or with modular flexibility (e.g. end-effector change) that can be fully synchronized with the buildings

modular structure through ROD. Likewise, the analysis of the variability and of applied ROD methods shows that on-site factories can be adapted to a certain extent (e.g. within a typology for which they are developed, see analysis of variability and application of ROD for each system in **5.2** and **5.3**) to various building projects and thus used to automate the subsequent construction of differently designed and shaped buildings. Although organizationally this capability has not yet been fully used, technically speaking, the analysis showed that the capability to mass customize buildings is basically embedded in the modular approach most systems followed. The approach presented and discussed in **chapter 6** would, apart from the flexibility, add speed (real-time) and efficiency to the manufacturing technology and thus integrate further MC characteristics.

4. **Large-scale deployment necessitates the radical and co-adapted change of manufacturing, technology, organization, product and associated business models.** The analysis of Automated/Robotic On-site Factories deployed to date from both a technical (see **5.2** and **5.3**) and an efficiency viewpoint (see **5.4**), revealed that the approach is feasible from a technical point of view, but that in terms of efficiency, the only improvements so far achieved, which can be considered comparable to conventional and non-machine technology-based construction, are marginal. Therefore in **chapter 6** a more radical approach to real-time and building integrated ONM was suggested and discussed. This approach would not only improve or double productivity, but would be able to multiply performance. It was shown that the automated manufacturing technology that accompanies a shift from an arts and crafts based industry to an industry based on systematization and machine technology, needs to be able to not only improve or double productivity, but to multiply performance (e.g. reduction of construction time to 1/10th compared to conventional construction, zero-waste, and defect free product, likewise, see **3.3**). This can be achieved by the suggested approach by JIS, JIT material flow on-site on a 24/7 basis, reducing any idle or downtime in the site factory. Following the hypotheses set out in **1.6**, in **chapters 5, 6** and **7**, it was discussed that the efficient deployment of Automated/Robotic On-site Factories and its sub-technologies requires not only a more radical change of manufacturing technology. The analysis and discussions showed in particular that a radical and co-adapted change of the product and thus the building's structure and modularity has to be implemented parallel to novel ONM technology. This motivated the author to set out research questions for future research in **chapter 8**.
5. **Automated/Robotic On-site Factories can be the basis for RTE in construction:** Although it was shown in **chapter 5** (in particular, see **5.4** and **5.5**) that the current generation of Automated/Robotic On-site Factories is not able to achieve a fast and real-time like delivery of customized products (although it is able to customize on the basis of automated manufacturing technology, it is as yet not able to do so fast and efficient enough), the more radical approach presented and discussed in **chapter 6** would be able to do so. It was shown that a re-thinking of the approach on the basis of the formerly analyzed systems and technologies would be able to lay

the basis for a construction industry being finally able to produce and, over time, adapt buildings according to customer demands with minimal delay in a near real-time manner. The fast or nearly instant availability of buildings and, with them, associated functionalities, would enhance the value of the product for the customer and at the same time reduce upfront costs and the risk for the developer (see **6.1.9**, **6.1.13** and also **7.1.1**). During long construction projects, the local economic situation can change and negatively affect the assumed building value (see **2.1**). With rapid or nearly instant availability, demand and fulfilment could be aligned to each other in nearly real-time, according to the philosophy of the RTE. Shortened construction periods could also be used to gain time for the adaptation of the building product to customer demands. It was also shown that the product value can be further enhanced by integrated maintenance, rearrangement and deconstruction technology. The enduring integration of the automated construction technology into the building after completion, and its use for automated maintenance, re-arrangement and deconstruction enhances the value of the building, and the height of the income payments generated by the building. Higher income payments can be used to compensate the cost for the automated construction technology (GF, GSSF, crabs, sensor systems and measuring technology for positioning, etc.; see also **6.1.9** and **6.1.12**). The cost for the novel ONM construction technology can thus be partly integrated into the budgets for building technology, maintenance and facility managements. Furthermore it was shown, that re-customization and deconstruction can be reactivated very quickly for change during the building's whole life cycle.

6. **Switch to an OEM-like industry structure:** In **chapter 2** it was shown that an OEM-like integration structure accompanies the introduction of advanced manufacturing technology in many industries. It goes along with changes to product structure (see **2.2**), manufacturing organization (see **2.3**) and automation and robot technology (see **2.4**). The analysis of the Japanese LSP industry, its manufacturing technology, organizational structures and product structures (see **3.2** and **3.2.4** in particular) revealed that the shift to automated OFM can be accomplished best by a change to the original product structure as well as the shift to an OEM-like industry structure – both directed at reducing complexity of the assembly of components, modules and units on the final assembly line. However, the analysis also showed that the approach of shifting the manufacturing of components, modules and units into off-site factories has its limitations (see **3.4**). OFM is not able to structure and automate the whole construction process. Other industries (see **3.3**), in particular the shipbuilding industry (see **3.3.2**), aircraft industry (see **3.3.3**) and tunneling industry (see **3.3.1**), that are similar to the construction industry, and are required to deliver highly complex, large-sized and customized products, have already gone a step further by developing highly structured, mechanized or automated fixed-site or on-site final assembly methods. On the level of BCM and LSP, increasing flexibility of automation and robot technology together with F&I strategies increases the capability of varying or customizing the end products. In order to simplify (and thus

structure) final assembly further, and in order to gain more flexibility and choice related to components, the mentioned industries have adopted and currently refine OEM-like industry structures (for example, the final assembly of cars can be achieved by that approach at the Micro Compact Car Factory in Hambach that manufactured Daimler's Smart within 3.5 hours lead time, see 2.3). In current on-site focused and labor-based construction practice, both real modularity and the application of connectors that allow for simplified and fast connections are not common practice. It was therefore discussed, that in order to structure the on-site environment and reduce complexity on-site (e.g. through the number of assembly operations, or kinematic complexity), an OEM-like industry structure, shifting the production of components, modules and units to internal and external company suppliers has to accompany the introduction of Automated/Robotic On-site Factories (see 6.1.9). Like in any other industry, the value and complexity of work pieces or products is rising along the value chain in construction. In conventional construction, a multitude of low complexity single parts, components, and sometimes modules, are assembled directly at the construction site. Thus, the operational transformation of "inputs" into "outputs" is done directly on the construction site. This also means that the on-site process becomes complex as a multitude of logistics and assembly processes related to rather small and unprepared parts has to be coordinated, managed and controlled. In automation, and robotics in construction, which sees the building being created as a product, complexity can subsequently be reduced along various steps in the value chain (see 6.2.6 and 6.2.10). In current approaches to Automated/Robotic On-site Factories, companies pre-structure buildings and prefabricate rather low-level components delivered by company internal entities. However, this cannot yet be considered as an OEM-like integration structure. A full integration of Automated/Robotic On-site Factories with the BCM and LSP industry in an OEM-like industry structure as suggested in chapter 6 would enable such complexity to be reduced further by an applied OEM approach. On-site environments can then be fully pre-structured and turned into factories that finally might allow for the efficient use of automation and robot technology.

- 7. Instant realization of Automated/Robotic On-site Factories through coordinated R&D and technology transfer possible:** The development of automated construction sites by Japanese companies evolved under the lead of a main contractor (e.g. Shimizu, Kajima) technology providers (e.g. Komatsu, Hitachi) and achieved, from a technological perspective, an advanced performance (some systems were even capable of full automation of the component installation process!). However, the development consortia and projects did not fully integrate the value system or value chain as is done today in Germany by the AAL-funding line, for example (in particular, see 7.1.3). As today, thanks to Japanese R&D in the 1980s and 1990s, the conceptual, strategic and technological basis for automated construction sites exists; future funding programs can cover both long-term and short-term R&D activity, or even focus on short-term applicability and economic

feasibility. A future funding initiative or program for real-time and building integrated automated construction was outlined in detail in **7.1**. The author of this thesis is well aware, that the required strategic and technological developments require resources, funding programs, education, an increase in R&D activity and systematic ways to innovate and/or transfer technologies. As the way to the suggested approach has yet to be pioneered, A roadmap to economic feasibility (see **7.1**) as well as methods for systematic and targeted innovation generation and management (see **7.2**) related to the approach presented in chapter 6 were discussed. It was shown that an instant realization of Automated/Robotic On-site Factories through coordinated R&D and technology transfer, as set out as hypothesis in **1.6** is difficult to achieve as the approach requires a co-adaptation of manufacturing technology, organizational structures and products, and thus a radical change of the whole industry (see **6.1**). However, it was discussed that a combination of short-term funding, long-term funding of industry consortia representing the whole value chain (see **7.1.3**), in combination with innovation and technology transfer strategies (see **7.2** and **7.3**) can create in a step-by-step approach, feasible approaches for automated/robotic on-site construction.

8. **Reverse innovation:** As stated in the introduction, the main goal of this thesis was to search for a novel ONM technology (see **1.5**, **1.6** and **1.7**). Analysis and discussions throughout the thesis have shown, that besides ONM technology, complementary and closely linked OFM technology (upstream by suppliers) and manufacturing technology that allows the maintenance, change, customization and deconstruction of buildings (e.g. building integrated as proposed and discussed in detail in **6.1**) are solutions that can be advanced on the basis of already existing technologies. The automated/robotic on-site approach was analyzed on behalf of case studies of real applications in **chapter 5** and advanced in **chapter 6**. An approach was presented which could serve as the basis for a manufacturing technology that is able to mass-customize highly complex products such as buildings in a nearly real-time manner. It has been shown, that the perfection of such an approach can be used for the individual, automatic and OPF manufacturing of complex products in manufacturing in general (**see 7.3**). Industries manufacturing highly complex products could learn from the above described concepts pioneered in the construction industry, for example how to mass customize cars, business jets, passenger aircrafts, complex large-sized ships for the oil, gas and cruise industries, and infrastructures such as roads, bridges and tunnels. General manufacturing industries could also profit and learn from sustainable manufacturing strategies such as zero-waste manufacturing, re-customization and urban mining, which could be pioneered in the construction industry along with the implementation of Automated/Robotic On-site Factories (see in particular **7.3.3**). Finally, as a guideline for further development of and the integration of product structures, organizational aspects, informational aspects with the proposed ONM technology, a framework for the concept of life cycle integrated manufacturing technology will be presented (see **7.4**). It was shown that such a framework on the basis of the manufacturing

technology discussed in this thesis could turn the manufacturing industry into an incubator and pioneer of future manufacturing systems for highly complex products (see 7.3.2).

Although this thesis focused on novel manufacturing technology and in particular novel ONM technology for construction, it has been shown and discussed throughout the thesis that a change in manufacturing technology is highly interdependent with changes concerning product structures, organizational aspects and informational aspects. In particular, the author of this thesis thinks that a change of the product, its structure, quality and performance in construction is key for the creation of a necessity and demand for the suggested manufacturing technology, and therefore, in his future research wants to emphasize the enhancement of performance and complexity of products in construction. Both the introduction of a novel ONM technology and the change to more complex products in construction has to be thought of in parallel.

On the one hand, products such as cars, aircrafts and ships are products which concentrate much more on advanced technology than buildings, and which require high precision and quality. In that industry, performance, the quality and precision levels required have made the products so complex that their assembly in SEs by automation and robot technology is almost inevitable. Demand for novel manufacturing technology can definitely be created! On the other hand, advanced machine-based manufacturing technology, which creates the basis for continuous production process improvements, is a prerequisite for the enhancement.

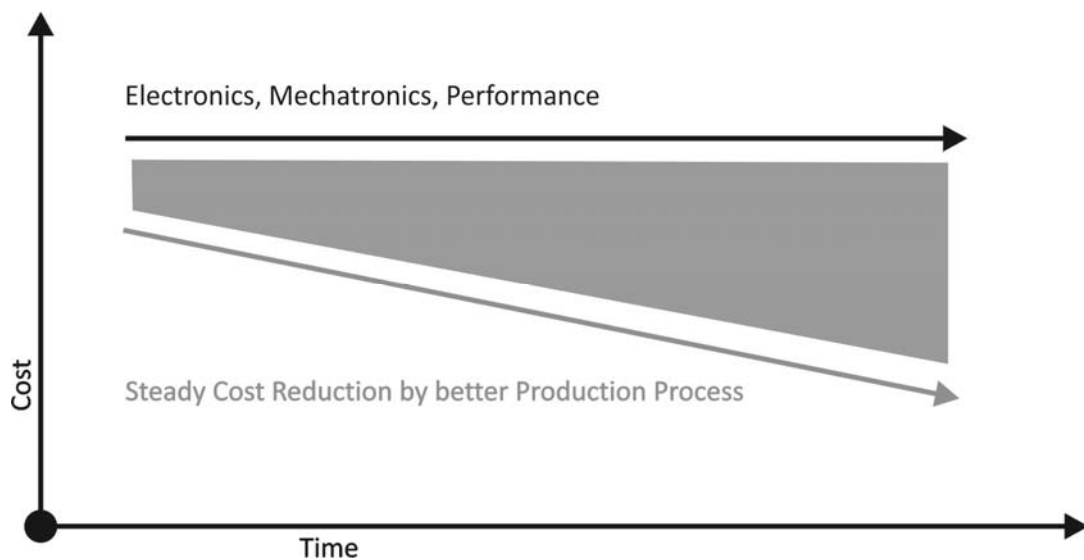

Figure 8-1: Relation between improvement of production processes and enhanced product performance

As mentioned in **7.2.2**, the automotive industry has been continuously optimizing the production process for decades, and thus has steadily reduced production costs. The savings are partly re-invested for research, development, increasing technology and also for optimization of the production process. This enables the companies to offer a better featured car with a constant price (see also *Figure 8-1*). The ability to do so is based on the structured, machine based and modular nature of the manufacturing technology in this industry. Labor based production systems such as in conventional construction have, due to human nature, a natural limitation, whereas technology-based production systems have virtually no limitation in performance (see also **2.1**, **2.4** and in particular **3.3.6**). Similarly, in construction, the improvement of construction process efficiency, as suggested in **6.1** could be used to free budgets for the development and deployment of better building technology and buildings with more “features” – which, at the same time, require further advancement of the manufacturing technology.

As part of his work as the Chair for Building Realization and Robotics at Technische Universität München (TUM), the author has contributed to, coordinated or set up three large university/industry research consortia, in which complex technological solutions have been developed and prepared for market:

Building Infill and Furniture equipped with sensor systems and augmented by digital services

BMBF funded Project “GEWOS, *Gesund Wohnen mit Stil*“. (German Ambient Assisted Living Program) Project Partners: TUM, EnOcean GmbH, Fraunhofer IIS, ISA Informationssysteme GmbH, Sportkreativwerkstatt, SOPHIA GmbH, TUM. Duration: April 2010 – April 2013. (16 SV 3970–3976), Funding of total Project: €3.6 million.



Modular Mechatronic Walls

Project Title: **LISA- Living Independently in Südtirol/Alto Adige**. Central R&D topic: Smart Walls - flexible room concepts, modular & flexible walls with integrated sensors for multi-generation living units. Projekt Partners: TUM, TIS Innovation Park, MM Design, Kompetenzzentrum Alpines Bauen, MM Design, Pfeiffer Architekten, Duration: 15.06.2011 – 31.10.2012 (Dekret des Landesrates Nr. 22/I-II vom 01.06.2010), Funding of total Project: €1.2 million.



Personalisierte Mobilität, Assistenz und Service Systeme

BMBF funded Project “PASSAge, *Personalisierte Mobilität, Assistenz und Service Systeme in einer alternden Gesellschaft*“.
(German Ambient Assisted Living Program) Project Partners: TUM, SOPHIA mit P. S. Südbayern GmbH , Smiles AG , Sunrise Medical GmbH, Haag-Rehatechnik GmbH & Co. KG , metaio GmbH, Heidelberg Medical Marketing GmbH, LMU, TUM is project coordinator. Duration: April 2012 – April 2016 (16 SV 5748), Funding of total Project €3.9 million.



GEWOS is currently being prepared for marketability and won the best product award at the AAL-Congress 2011. LISA is currently being advanced to LISA II, and PASSAge was recently recognized by the German science minister in 2012 as being highly relevant for Germany in terms of the country’s high-tech strategy and in the face of its ageing society. All three projects focused on the enhancement of the complexity of the built environment by embedded microsystem technology. Microsystems and data collection platforms can increasingly be established in the living environment. In terms of the imaginable services, this field has not yet been fully developed, providing the possibility of novel value creation models. Methods of service innovation have been analyzed by the author and realized within the mentioned projects. With the integration of microsystems technology into buildings and the bundling to and provision of services via buildings might, in the future, in fact lead to major change in construction from a products based to a more services oriented industry. The author of this thesis wants in his future research to analyze, in particular, and develop further the product and product-service structure of the products generated by construction industry, and to develop such approaches further in respect of the introduction of automated and robotic manufacturing technologies and complementary novel organizational and informational models, as discussed in this thesis.

Both in terms of manufacturing technology and product performance, an advanced construction industry could create a competitive advantage for the construction industry, as well as for the (especially in Germany, but also in other high-wage countries) strong machine, automation, robot and Information and Communication Technology (ICT) industries. It would reduce the possibility of business fields being taken over or processes and technologies being imitated by competitors from other countries (e.g. companies from low wage countries). Both in the automotive and aircraft industry, for example, the continuous enhancement of the product complexity and the manufacturing complexity is a powerful means by which to prevent imitation by, for example, companies from emerging economies. However, non-capital intensive and labor intensive work – as is the case in conventional construction in general (see also **2.1**) - can be imitated instantly and basically by any competitor. The low barrier for imitation by competitors also contributed (not alone,

but certainly in part) to the decline of the German construction industry (bankruptcy of Philip Holzmann AG, Russian takeover of Strabag, Spanish takeover of Hochtief, increasing share of foreign contractors). However, both in terms of manufacturing technology and product performance, an advanced construction industry could effectively use and augment the capabilities and resource available in high-wage countries.

References

ABCS (1993) 'Riverside Sumida Bachelor Dormitory Documentary Video' [VHS]. Tokyo: Obayashi Corporation

Adan, A.; Xiong, X.; Akinki, B.; Huber, D. (2011) 'Automatic Creation of Semantically Rich 3D Building Models From Laser Scanner Data', *Proceedings of 28th International Symposium on Automation and Robotics in Construction*, pp.343-348. Seoul, Korea: International Association for Automation and Robotics in Construction

Ahman, P. (2010) 'En rapportserie från sveriges byggindustrier' [lecture]. Presentation/Lecture given at Sveriges Byggindustrier Region Väst in Göteborg

Ahrens, H.; Bastian, K.; Muchowski, L. (2010) 'Handbuch Projektsteuerung - Baumanagement: Ein praxisorientierter Leitfaden' (4th edn). Stuttgart: Fraunhofer Irb Verlag

Aicher, O. (2010) 'Die Küche zum Kochen, Werkstatt einer neuen Lebenskultur' (3rd edn). Stauf: Ökobuch Verlag

AIJ (1990) 'Robotic Technology for Building Production' [research report], study conducted by the Architectural Institute of Japan (AIJ), Tokyo: AIJ

Airbus [site visit], site visit to Airbus Finkenwerder/Hamburg, Germany, May 2012

Ali, M. M. (2001) 'Art of the Sky Scraper – the genius of Fazlur Kahn'. New York: Rizzoli International Publications

Allwang, K. (2002) 'Werkzeugmaschinen – Bohren, Drehen, Fräsen'. Munich: Deutsches Museum

Anderl, R.; Castro, P. (1990) 'CAD/CAM – auf dem Weg zu einer branchenübergreifenden Integration'. Heidelberg: Springer-Verlag

Andersson, R.; Eckholm, A.; Jonsson, C.; Molnar, M.; Larsson, R. (2010) 'ICT and BIM in the Japanese Construction Industry', *Samhällsbyggaren* [online journal], pp. 46-51, <http://www.vbyggaren.se/pdf_arkiv/Samhallsbyggaren_6_10.pdf> accessed 05 Sept. 2011

Andres, J.; Bock, T.; Gebhardt, F.; Steck, W. (1994) 'First results of the development of the masonry robot system ROCCO: a fault tolerant assembly tool', *Proceedings of 11th International Symposium on Automation and Robotics in Construction*, pp. 87-93. Brighton (UK): International Association for Automation and Robotics in Construction,

- Arora, S.; Barak, B. (2009) 'Computational Complexity: A modern Approach'. Cambridge: Cambridge University Press
- AUDI [site visit], site visit to Audi Headquarter and Factory in Ingolstadt, Germany, December 2011
- AUTONOMIK - Autonome und simulationsbasierte Systeme für den Mittelstand' [website], <<http://www.autonomik.de>> accessed 01 Dec. 2012
- Backerra, H.; Malorny, C.; Schwarz, W. (2002) 'Kreativitätstechniken' (2nd edn). Munich: Carl Hanser
- Baldwin, C.Y.; and Clark, K.B. (2000) 'Design Rules: The Power of Modularity'. Boston: MIT Press
- Baron, R.; Alberti, K.; Gerber, J.; Jochem, E.; Bradke, H.; Dreher, C.; Ott, V.; Kristof, K.; Liedke, C.; Acosta, J.; Bleischwitz, R.; Brigenzu, S.; Busch, T.; Kuhnt, M.; Lemken, T.; Ritthoff, M.; Rosnow, J.; Supersberger, N.; Villar, A. (2006) 'Konzeption eines Programms für die Steigerung der Materialeffizienz in mittelständischen Unternehmen - Potential- und Hemmnisanalyse', [research report] Fraunhofer-Institut für System- und Innovationsforschung, Arthur D. Little GmbH, Wuppertal Institut für Klima, Umwelt, Energie (2006) Berlin: Federal Ministry of Economics and Technology
- Barth, H.; Wollert, F. (1998) 'Smates Konzept – vom Product zur Fabrik', *Facility Management*, No. 4/1998, pp. 30-35
- Berufsgenossenschaft der Bauwirtschaft* (German Association of Construction Workers) [website] <<http://www.bgbau.de>> accessed 23 Sept. 2012
- Blaser, W. (1987) 'Goldsmith, Myron: Buildings and Concepts'. Basel-Boston-Stuttgart: Birkhäuser
- Block, M., Greif, H. (2007) 'Smartville – Innovatives Automobilunternehmen der Zukunft', *Digitale Fachbibliothek Innovationsmanagement*, No 05.01, p.33-55, Symposium Publishing GmbH
- Bock, T. (1988) 'Robot Oriented Design' [Dr.-Ing. Dissertation], Faculty of Engineering, Chair of Building Production, The University of Tokyo
- Bock, T. (1998) 'Robotics in Architecture', Proceedings of La Science et la Technologie au Service de l'Architecture, Conference Europeenne sur l'Architecture UNESCO, Paris, France: Center Robotique Intégrée Ile de France
- Bock, T. (2009) 'Urban Mining - der nachhaltige Baubetrieb: Vom automatisierten Auf- zum Rückbau', *Festschrift TU Graz zum 40jährigen Jubiläum des Institutes für Baubetrieb und Bauwirtschaft*. Graz, Austria: Institutes für Baubetrieb und Bauwirtschaft

- Bock, T. (2012) 'Karakuri Kultur in Architektur und Bauwesen'. In: *Mensch-Roboter-Interaktionen aus interkultureller Perspektive- Japan und Deutschland im Vergleich*, Band 62: pp. 18-32, Publication Series of the Japanese German Center in Berlin
- Bock, T., Linner, T., Lee, S. (2009) 'Integrated Industrialization Approach for lean Off-/On - site Building Production and Resource Circulation', *Proceedings of 7th Global Conference on Sustainable Manufacturing (GCSM)*. India: GCSM
- Bock, T.; Linner, T. (2010a) 'Customized Automation and Robotics in Prefabrication of Concrete Elements'. In: Girmscheid, G.; F. Scheublin (2010), *New Perspective in Industrialization in Construction – A State-of-the-Art Report*, CIB Publication 329, pp. 207-231. Switzerland/Zurich: ETH Zürich
- Bock, T.; Linner, T. (2010b) 'From early Trials to advanced Computer Integrated Prefabrication of Brickwork'. In: Girmscheid, G.; F. Scheublin (2010) *New Perspective in Industrialization in Construction – A State-of-the-Art Report*; CIB Publication 329, pp. 161-181. Switzerland/Zurich: ETH Zürich
- Bock, T.; Linner, T.; Eibisch, N. (2011) 'Vertical Shipyard: Technology Transfer for Automated Con- and Deconstruction', *Proceedings of 28th International Symposium on Automation and Robotics in Construction*, pp652-658. Seoul, South Korea: International Association for Automation and Robotics in Construction
- Bock, T.; Linner, T.; Eibisch, N.; Lauer, W. (2010) 'Fusion of Product and Automated-Replicative Production in Construction', in: Gasparik, J. (ed.), *Proceedings of 27th International Symposium on Automation and Robotics in Construction (ISARC)*, pp. 12-21. Bratislava: University of Technology in Bratislava
- Bock, T.; Linner, T.; Georgoulas, C.; Mayr, M.; Meyer-Andreas, J. (2012) 'Innovation Deployment Strategies in Construction', *Proceedings of Creative Construction Conference*. Budapest, Hungary
- Bock, T.; Linner, T.; Lauer, W.; Eibisch, N. (2010) 'Automatisierung und Robotik im Bauen', *Arch+ Zeitschrift für Architektur und Städtebau*, 198/199: Haus der Zukunft, Volume 43: pp. 34-39
- Bock, T.; Linner, T.; Miura, S. (2011) 'Robotic High-Rise Construction of Pagoda Concept: innovative earthquake-proof Design for the Tokyo Sky Tree', *Proceedings of Council for Tall Buildings and Urban Habitat (CTBUH) World Conference*, Seoul, Korea: CTBUH
- Boeing - Defence, Space and Security Division [website],
<<http://www.boeing.com/rotorcraft/military/ah64d/index.htm>> accessed 06 May 2012

- Boning, D.; Hardt, D. (2009) 'Control of Manufacturing Processes' [lecture], from: *Lecture 3, MIT Open Course Ware*, <<http://ocw.mit.edu/courses/mechanical-engineering/2-830j-control-of-manufacturing-processes-sma-6303-spring-2008>> accessed 06 May 2012
- Bräunl, T. (2008) 'Embedded Robotics, Mobile Robot Design and Application with Embedded Systems' (3rd edn). Berlin-Heidelberg: Springer
- Bräunl, T. (2008) 'Embedded Robotics'. Berlin-Heidelberg: Springer
- Brinkley, D. (2003) 'Wheels for the World: Henry Ford, His Company, and a Century of Progress'. London: Penguin Books
- Browning, E. A. (2011) 'Roadbuilding Construction Equipment at Work: Building the Early Interstate Highways Through New England's Green Mountains'. Hudson WI: Iconografix
- Caldas, C. H.; O'Brien, W. J. (2009) 'Computing in Civil Engineering', *Proceedings of the 2009 international Workshop on Computing in Civil Engineering*. Austin: American Society of Civil Engineers
- Calinescu, A. (2002) 'Manufacturing Complexity: An Integrative Information-Theoretic Approach' [PhD Dissertation], Department of Engineering Science of the University of Oxford
- Cameron, E.; Green, M. (2009) 'Making Sense of Change Management: A Complete Guide to the Models, Tools and Techniques of Organizational Change'. London: Kogan Page
- Cheng, T.; Teizer, J. (2011) 'Crane Operator Visibility Of Ground Operations', *Proceedings of 28th International Symposium on Automation and Robotics in Construction*, p. 699-705. Seoul, Korea: International Association for Automation and Robotics in Construction
- Chesbrough, H. (2011) 'Open Services Innovation: Rethinking Your Business to Grow and Compete in a New Era' Sussex: John Wiley & Sons
- Chesbrough, H. (2011) 'Open Services Innovation' San Francisco: Jossey-Bass
- Chesbrough, H.; Vanhaverbeke, W.; West, J. (2008) 'Open Innovation – Researching a new Paradigm' New York: Oxford University Press
- Christensen, C. M.; Overdorf, M.; MacMillan, I. (2001) 'Harvard Business Review on Innovation'. Boston: Harvard Business School Press
- Cohen, J.-L. (2007) 'Ludwig Mies van der Rohe' (2nd edn). Basel: Birkhäuser
- Cohrs, H.-H. (1995) 'Faszination Baumaschinen' Hildesheim: Gisel Verlag
- Cohrs, H.-H. (2012) 'Jahrbuch Baumaschinen 2012'. Brilon: Verlag Podszun
- Cohrs, H.-H.; Oberdrevermann, R. (2004) 'Giganten im Erd- und Tagebau'. Stuttgart: Motor Buch Verlag

- Construction Industry Handbook (2004) 'Construction Industry Handbook 2004' [research report]. Tokyo: Japan Federation of Construction Contractors
- Construction Industry Handbook (2010) 'Construction Industry Handbook 2010' [research report]. Tokyo: Japan Federation of Construction Contractors
- Construction Industry Handbook (2012) 'Construction Industry Handbook 2012' [research report]. Tokyo: Japan Federation of Construction Contractors
- Council for Construction Robot Research (1999) 'Construction Robot System Catalogue in Japan' [research report]. Tokyo: Robot Association
- Cousineau, L.; Miura, N. (1998) 'Construction Robots: The Search for New Building Technology in Japan'. Reston: American Society of Civil Engineers (ASCE)
- Curtin, D.; Drath, S.; O' Brien, M. (1983) 'Skidmore, Owings & Merrill - Architektur und Städtebau' (Translation into German by Grube, O. W.). Munich: Verlag G. Hatie
- Cusumano, M. A. (2010) 'Staying Power: Six Enduring Principles for Managing Strategy and Innovation in an Uncertain World'. Oxford: Oxford University Press
- DEKRA (2008) '2. DEKRA Studie zu Baumängeln an Wohngebäuden' [research report]. Saarbrücken: DEKRA Real Estate Expertise GmbH
- Diversified Metal Services Industry (DMSI) (2012) 'Water Jet Cutting Services' [online article], <<http://www.diversifiedmetalservices.com/waterjet.html>> accessed 23 Jun. 2012
- Dong, X., Yurong M., and Haile E. (2005) 'Work-related fatal and non-fatal injuries among construction workers: 1992- 2003'. Silver Spring: The Center to Protect Workers' Rights (CPWR)
- Douglas, I.; Hodgson, R.; Lawson, N. (2002) 'Industry, environment and health through 200 years in Manchester', *Journal of Ecological Economics*, Issue 41 (2002): 235–255
- Eastman, C.; Teichholz, P.; Sacks, R.; Liston, K. (2008) 'BIM Handbook' New Jersey: John Wiley and Sons
- Effizienzfabrik - Innovations-Plattform Ressourceneffizienz in der Produktion [website], <www.Effizienzfabrik.de> accessed 18 August 2012
- Eibisch, N. (2010) 'Der Helixturm von Konrad Zuse'. In: Füßl, W. (2010) *100 Jahre Konrad Zuse, Einblicke in den Nachlass*. Munich: Deutsches Museum
- EIMaraghy, H.; Wiendahl H.-P. (2009) 'Changeability - An Introduction in Changeable and Reconfigurable Manufacturing Systems'. In: EIMaraghy, H. A. (2009) *Changeable and Reconfigurable Manufacturing Systems*. London: Springer

- Essinger, J. (2004) 'Jacquard's Loom – How a hand loom led to the birth of the information age'. Oxford: Oxford University Press
- Farnie, D.A (1979) 'The English Cotton Industry and the World Market 1815–1896'. Oxford: Oxford University Press
- Federal Statistical Office (2012) Federal Statistical Office [website], <www.destatis.de> accessed 23 Sept. 2012
- Ferguson, E. S. (1962) 'Kinematics of mechanisms from the time of watt'. In: *Contributions from the museum of history and technology Washington*, Paper 27, pp. 185-230
- Fewings, P. (2012) 'Construction Project Management: An Integrated Approach' (2nd edn). London: Routledge Chapman & Hall
- Frantzen, C.; Kirn, S.; Kaak, M.; Sturm, A. (2012) 'Research Project AutoBauLog – Autonomy and Multi-Agent systems for job-site'. In: Schwieger, V.; Böttinger, S.; Zheng, B (eds) *Proceedings of the 3rd International Conference on Machine Control & Guidance (MCG)*. Stuttgart, Germany: University of Stuttgart
- Frederick, C. (1912) 'The New Housekeeping, Efficiency Studies in Home Management' [research report]. New York: Doubleday, Page & Company, originally published in *Ladies' Home Journal*, Sept.-Dec. 1912
- Fujii, T.; Hagiwara, C.; Morita, M.; Miyaguti, M. (1995) 'Development of Roof Push Up Construction Method', *Automation and Robotics in Construction*, Vol. 7: 193-201. Elsevier Science, Budny, E.; McCrea, A.; Szymanski, K.
- Fujimoto, T. (1999) 'The Evolution of a Manufacturing System at Toyota'. Oxford/ New York: Oxford University Press
- Fujimoto, T. (2007) 'The Bubble Burst and Recession' [lecture], Lecture No. 13 from lecture series: *Economic Development of Japan*. The University of Tokyo
- Furuse, J.; Katano, M. (2006) 'Structuring of Sekisui Heim automated parts pickup system (HAPPS) to process individual floor plans', *Proceedings of 23rd International Symposium on Automation and Robotics in Construction*, pp. 352-356. Tokyo, Japan: International Association for Automation and Robotics in Construction
- Gady, B. R. (2005) 'Success and Improvements of the mobile Parts Hospital', *Proceedings of Commercial Technologies for Maintenance Activities Symposium 2005*, Tacoma: National Center for Manufacturing Sciences
- Galluzzi, P. (1996) 'Gli ingegneri del Rinascimento da Brunelleschi a Leonardo Da Vinci' Firenze: Istituto e Museo di Storiadella Scienza

- Gatti, U. (2012) 'Measuring and Evaluating Physical Strain to improve Construction Workforce Productivity' [PHD Dissertation], The University of New Mexico Albuquerque
- Gatti, U. (2012) 'Measuring and Evaluating Physical Strain to improve Construction Workforce Productivity' [PHD Dissertation], The University of New Mexico Albuquerque
- Gaugel, T.; Dobler, H. (2001) 'Advanced Modular Micro-Production System (AMMS)', *Microrobotics and Microassembly*, No. 3
- GDV (2012) 'Container Handbook' Berlin: Gesamtverband der Deutschen Versicherungswirtschaft e.V. (GDV)
- Georgoulas, C.; Linner, T.; Kasatkin, A.; Bock, T. (2012) 'An Aml Environment Implementation: Embedding TurtleBot into a novel Robotic Service Wall', *Proceedings of 7th German Conference on Robotics*. Munich, Germany: VDE Verlag
- Gershenfeld, N. (2005) 'FAB: The coming revolution on your desktop – from personal computers to personal fabrication'. New York: Basic Books
- Gilmore, J. H.; Pine B. J. (2000) 'Customization that Counts'. In: *Markets of One – Creating Customer-Unique value through Mass Customization*. Boston: Harvard Business Review Press
- Gotthelf, F. (1960) 'Ernst Neufert. Ein Architekt unserer Zeit'. Frankfurt/Berlin: Verlag Ullstein
- Gould, F.; Joyce, N. (2008) 'Construction Project Management' (3rd edn). New Jersey: Prentice Hall
- Govindarajan, V.; Trimble, C. (2012) 'Reverse Innovation – Create far from Home, win Everywhere'. Boston: Harvard Business Review Press
- Goyo/Penta Ocean (2001) 'FACES Documentary Video' [VHS]. Tokyo: Goyo/Penta Ocean
- Greiner, P.; Mayer, P. E.; Stark, K. (2002) 'Baubetriebslehre – Projektmanagement'. Wiesbaden: Vieweg+Teubner
- Grube, O. W.; Krehl-von Mühlendahl, N. (1974) 'Architektur von Skidmore, Owings & Merrill, 1963-1973'. Munich: Verlag. G. Hatie
- Grube, O. W.; von Seidlein, P. C.; Fischer, W. (1973) '100 Jahre Architektur in Chicago: Kontinuität von Struktur und Form'. Munich: Neue Sammlung Staatliches Museum für angewandte Kunst
- Grunau, P; Hartung, S. (2012) 'Der Arbeitsmarkt im Bausektor 2010 - Branchenbericht'. Nürnberg: Bundesagentur für Arbeit und Institut für Arbeitsmarkt und Berufsforschung

- Günthner, W.; Borrmann, A. (2011) 'Digitale Baustelle- innovativer Planen, effizienter Ausführen: Werkzeuge und Methoden für das Bauen im 21. Jahrhundert'. Frankfurt/Heidelberg: VDI & Springer Verlag
- Hankammer, G. (2007) 'Abnahme von Bauleistungen- Hochbau: Erkennen und Beurteilen von Planungs- und Ausführungsmängeln'. Köln: Verlagsgesellschaft Rudolf-Müller
- Hartschen, M.; Scherer, J.; Brügger, C. (2006) 'Innovations Management'. Offenbach: Gabal Verlag
- Hasegawa [site visit and interview], site visit by the author and interview with Prof. T. Hasegawa in his lab, Hasegawa & Morooka Lab: Human-Symbiotic intelligent Robot Systems, Kyushu University, December, 2010
- Hasegawa, Y. (1985) 'Robotization of Reinforced Concrete Building Construction in Japan', *Proceedings of 3rd International Symposium on Automation and Robotics in Construction*, pp. 423-433. Marseille, France: International Association for Automation and Robotics in Construction
- Hasegawa, Y. (1999) 'Robotization in Construction' Tokyo: Kogyo Chosakai Publishing
- Hasegawa, Y.; Onoda, T.; Tamaki, K. (1992) 'Modular Robotic Application for flexible Building Constuction', *Proceedings of 13th International Symposium on Automation and Robotics in Construction*, pp. 113-122. Tokyo, Japan International Association for Automation and Robotics in Construction
- Hayes, J. (2010) 'Theory and Practice of Change Management' (3rd edn). Hampshire: Palgrave Macmillan
- Hellstern, K. (2011) 'Liebherr Großkrane: LTM 1800, LG 1550, LTR 1800, LR 1550'. Brilon: Verlag Podszun
- Helmus, M. (2012) 'Arbeitsschutz im Bauwesen mit RFID: Forschungsbericht zum Projekt Sicherheitstechnik mit RFID - Entwicklung, Erprobung und Optimierung'. Wiesbaden: Vierweg+Teubner
- Helmus, M.; Meins-Becker, A.; Laußart, L.; Kelm, A. (2009) 'RFID in der Baulogistik'. Wiesbaden: Vierweg+Teubner
- Hemmerling, M; Tiggemann, A. (2010) 'Digitales Entwerfen'. Paderborn: Wihelm Fink Verlag
- Hempstead, B.; DeVlieg, R.; Mistry, R.; Sheridan, M. (2001) 'Drill and Drive End Effector' *Technical Paper*, 2001-01-2576. Society of Automotive Engineers
- Herrenknecht [site visit and interview], site visit by the Author and interview with leading engineers, managers and company owner Dr. M. Herrenknecht, Schwanau, Germany, November 2012

- Herrero, J.; Pascoe, S. (2002) 'Estimation of technical Efficiency: a review of some of the stochastic frontier and DEA software', *Computers in higher Education Economics Review (CHEER)*
- Hills, R. (2007) 'Richard Roberts (1789-1864), pioneer of production engineering in Manchester'. In: Pickstone, V. (2007) *Manchester Regional History Review*, Volume 18: The History of Science and Technology in the North West, Lancaster: Carnegie Publishing
- Horne, D. F. (1986) 'Aircraft Production Technology'. Cambridge: Cambridge University Press
- Hovestadt, L. (1994) 'A4: Digitales Bauen - Ein Modell für die weitgehende Computerunterstützung von Entwurf, Konstruktion und Betrieb von Gebäuden' [research report]. *Fortschrittsberichte VDI*, Volume 20: Rechnerunterstützte Verfahren, 120. Düsseldorf: VDI-Verlag
- Hovestadt, L.; Haller F.; Gauchel J.; Drach A. (1989) 'Ein intelligentes CAD-System für die Planung und Verwaltung von Leitungen in haustechnischen Gebäuden' [research report]. *VDI-Berichte*, 775, Düsseldorf: VDI-Verlag
- Hovestadt, V. (1998) 'Informationsgebäude – ein Integrationsmodell für Architektur und Informationstechnologie' [Dr.-Ing. Dissertation], Technische Hochschule Karlsruhe, Institut für Bauproduktion
- Hovestadt, V.; Hovestadt, L. (1998) 'The Armilla Project', *Automation in Construction*, 8, 3: 325-337
- Howe, J. (2009) 'Crowdsourcing: Why the Power of the Crowd Is Driving the Future of Business'. New York: Three Rivers Press/Crown Publishing
- Hvam, L.; Mortensen, N. H.; Riis, J. (2008) 'Product Customization'. Berlin-Heidelberg: Springer-Verlag
- Ikeda, Y.; Harada, T. (2006) 'Application of the automated building construction system using the conventional construction method together', *Proceedings of 23rd International Symposium on Automation and Robotics in Construction*, pp. 722-727. Tokyo, Japan: International Association for Automation and Robotics in Construction
- Institut der deutschen Wirtschaft in Köln (2012) 'Deutschland in Zahlen 2012'. Köln: Institut der deutschen Wirtschaft in Köln Medien GmbH
- Ishiguro, H.; Intelligent Robotics Laboratory, University of Osaka, Japan [website], <<http://www.geminoid.jp/en/mission.html>> accessed 26 Aug. 2012-1

- Itou, M.; Nishita, K.; Houkyou, M. (1994) 'Application of All-Weather Automatic Building Construction Systems'. Japan: Construction Robot Symposium
- Junghanns, K. (1994) 'Das Haus für alle'. Berlin: Ernst & Sohn
- Kajima (2000) 'AMURAD Documentary Video' [VHS]. Tokyo: Kajima
- Kajima (2009) 'Documentary Picture Set' [JPEG]. Tokyo: Kajima Corporation Research Department
- Kajima [interview], interview with Kajima R&D staff at ISARC 2011. Seoul, Korea, June 2011
- Kazi, A. S. (2005) 'ICT in Construction and Facility Management'. Finland: VCTT & RIL
- Kazi, A. S. (2005) 'Systemic Innovation in the Management of Construction Projects and Processes'. Finland: VCTT & RIL
- Kazi, A. S.; Eichert, J.; Boudjabeur, S. (2009) 'ManuBuild Open Building Manufacturing – System Handbook'. Moorgate: ManuBuild
- Kessoudis, K.; Lodewijks, J. (2012) 'Prozessintegration: Von 3D/BIM zu 5D', *Der Bauingenieur*, 2012/2: 82-88. Springer/VDI Verlag: Düsseldorf
- Kief, H. B.; Roschiwal, H. A. (2011) 'CNC-Handbuch 2011/2012'. Munich: Carl Hanser Verlag
- Kirchbach, K.; Bregenhorn, T.; Gehbauer, F. (2012) 'Digital Allocation of Production Factors in Earth Work Construction', *Proceedings of the 20th Annual Conference of the International Group of Lean Construction*. San Diego, USA: International Group of Lean Construction
- Kiva Systems (2012) 'Kiva Systems'. *IEEE Spectrum*, July 2008, pp. 26-34
- Klause, G. (1992) 'CAD, CAE, CAM, CAP, CIM Lexikon'. Böblingen: Expert Verlag
- Knight, T.; Sass, L. (2010) 'Looks count: Computing and constructing visually expressive mass customized housing'. *Artificial Intelligence for Engineering Design, Analysis, and Manufacturing*, Vol. 24: 425-445
- Korea University (2010) 'Documentary Video Robotics and Crane based Automated Construction System (RCACS) for High-rise Buildings' [Windows Media Video]. Seoul: Korea University
- Kress, C (2011) 'Adolf Sommerfeld - Andrew Sommerfield'. Berlin: Lukas Verlag
- Kress, C. (2008) 'Zwischen Bauhaus und Bürgerhaus. Die Projekte des Berliner Bauunternehmers Adolf Sommerfeld' [PHD Dissertation], Technische Universität Berlin

- Kuka (2012) 'KUKA Light Weight Robot' [online article], <http://www.kuka-robotics.com/en/pressevents/news/NN_060515_Automatica_02.htm> accessed 08 May 2012
- Kuka [site visit], site visit to KUKA Headquarter and KUKA Factory by the author, Augsburg, December 2011
- Kunkel, R. C. (2009) 'DDR Baumaschinen: 1945-1990 (Typenkompass)' Stuttgart: Motor Buch Verlag
- Kurek, R. (2004) 'Erfolgsstrategien für Automobilzulieferer - Wirksames Management in einem dynamischen Umfeld'. Berlin-Heidelberg-New York: Springer
- Lamb, T. (2003) 'Ship design and construction'. Jersey City: Society of Naval Architects and Marine Engineers
- Lämmel, U.; Cleve, J. (2008) 'Künstliche Intelligenz'. Munich: Hansa Verlag
- Laurenza, D.; Taddei, M.; Zanon, E. (2005) 'Leonardo's Machines'. David & Charles Books
- Ledderboge, O.; Danilow, N. N.; Scheidig, K.; Schlorke, W.; Schallehn, W. (1962) 'Montage von Beton- und Stahlbetonfertigteilen'. Berlin, East Germany (GDR): VEB Verlag für Bauwesen
- Lee, S.-Y. (2008) 'Human-Robot Cooperation for Installing Bulk Building Materials at Construction Sites' [Dr.-Ing. Dissertation], Seoul: Hanyang University, Department of Mechanical Engineering
- Leimböck, E.; Klaus, U. R.; Hölckermann, O. (2007) 'Baukalkulation und Projektcontrolling: unter Berücksichtigung der KLR Bau und der VOB'. Wiesbaden: Vieweg+Teubner
- Lindemann, U.; Reichwald, R.; Zäh, M. (2006) 'Individualisierte Produkte. Komplexität beherrschen in Entwicklung und Produktion'. Heidelberg: Springer
- Lindl, H.; Song, H.-S. (2010) 'Dålig produktivitets-utveckling I byggindustrin'. [Research Report]. Stockholm: Kungliga Tekniska Högskolan
- Linner, T. (2010) 'Komponentenzirkulation und Re-Customization', *Technik in Bayern: Bautechnik*, 05/2010:44-45
- Linner, T., Bock, T. (2009) 'Smart Customization in Architecture: Towards Customizable Intelligent Buildings', *Proceedings of Conference on Mass Customization, Personalization and Co-creation (MCPC 2009)*, Helsinki, Finland: MCPC 2009
- Linner, T., Kranz, M., Roalter, L., Bock, T. (2010) 'Compacted and Industrially Customizable Ambient Intelligent Service Units: Typology, Examples and Performance', *The 6th International Conference on Intelligent Environments (IE 10)*, Kuala Lumpur, Malaysia: IE 10

- Linner, T.; Abazovic, I.; Ellmann, B.; Bock, T. (2011-b) 'Development of Performance Oriented Robotic Environments through Process Analysis/Modification', *Proceedings of 28th International Symposium on Automation and Robotics in Construction*, pp. 57-63. Seoul, Korea: International Association for Automation and Robotics in Construction
- Linner, T.; Bock, T. (2010) 'From Space System Engineering to Earth System Engineering: A new Method for Developing Technologies being compatible with Society, Ecology and Economy', *Proceedings of First International Conference on Sustainability and the Future*, Cairo: British University in Egypt
- Linner, T.; Bock, T. (2012) 'Evolution of large-scale Industrialization and Service: Innovation in Japanese Prefabrication Industry', *Journal of Construction Innovation: Information, Process, Management*, Vol. 12, 2:156-178.
- Linner, T.; Kranz, M.; Roalter, L.; Bock, T. (2011-a) 'Robotic and Ubiquitous Technologies for Welfare Habitat', *Journal of Habitat Engineering*, 2011, Vol. 03, 1: 101-110
- Linner, T.; Thuesen, C.; Bock, T. (2010) 'Networked Energy Platforms: A New Concept for Closed Loop Resource Utilization in Open Building Systems', *Proceedings of First International Conference on Sustainability and the Future*, Cairo: British University in Egypt
- Lutz, U.; Klapproth, T. (2003) 'Riskmanagement im Immobilienbereich: Technische und wirtschaftliche Risiken'. Berlin-Heidelberg: Springer
- Maeda, J. (1994) 'Development and Application of the SMART System', *Automation and Robotics in Construction*, Vol. 6: 457-464. Oxford: Elsevier Science
- Maeda, J.; Miyatake, Y. (1997) 'Improvement of a Computer Integrated and Automated Construction System for High-rise Building and its Application for RC (Rail City) Yokohama Building', *Proceedings of 14th International Symposium on Automation and Robotics in Construction*, pp. 139-146. Pittsburgh, USA: International Association for Automation and Robotics in Construction
- Mathia, k. (2010) 'Robotics for Electronics Manufacturing'. Cambridge: Cambridge University Press
- May, M. (2006) 'CAFM-Handbuch - IT im Facility Management erfolgreich einsetzen'. Heidelberg-Berlin: Springer
- Migliaccio, G.; Gatti, U.; Teizer, J. (2011) 'Remote Construction Worker Location, Activity and Safety Monitoring' *Proceedings of 28th International Symposium on Automation and Robotics in Construction*, pp. 650-651. Seoul, Korea: International Association for Automation and Robotics in Construction

- Milgrom, P.; Roberts, J. (1990) 'The Economics of Modern Manufacturing: Technology, Strategy and Organization' *American Economic Review* 80/3: pp. 511–528
- Miyakawa, H.; Ochiai, J.; Oohata, K.; Shiokawa, T. (2000) 'Application of automated building construction system for high rise office building', *Proceedings of 17th International Symposium on Automation and Robotics in Construction*, pp. 1-6 Taipei, Taiwan: International Association for Automation and Robotics in Construction,
- Moon, F.C. (2007) 'The Machines of Leonardo Da Vinci and Franz Reuleaux – Kinematics of Machines from the Renaissance to the 20th Century'. The Netherlands: Springer
- Moorehead, W. S. (2010) 'Field Robotics Driving Off-Road Equipment Productivity and Convenience' [invited talk], *Key Note at 41st International Symposium on Robotics (ISR)*, Munich, Germany
- Morita, M.; Muro, E.; Kanaiwa, T.; Nishimura, H. (1993) 'Study on Simulation of Roof Pushup Construction Method', *Automation and Robotics in Construction*, Vol. 5: 1-8, Elsevier Science, G. H. Watson, G. H.; Tucker, R. L.; Walters,
- Moselhi, O.; Khan, Z. (2012) 'Significance ranking of parameters impacting construction labor productivity', *Construction Innovation: Information, Process, Management*, Vol. 12, 3: 272 – 296
- Moselhi, O.; Leonard, C. A.; Fazio, P. (1988) 'Construction Productivity: Major Causes of Impact', *Transactions of American Association of Civil Engineers (AACE)*, pp. 101-107
- Murakami, K., Hasegawa T., Karazume R., Kimuro, Y. (2008) 'A Structured Environment with Sensor Networks for Intelligent Robots'. In: *Proceedings of IEEE Sensors 2008 Conference*, Lecce, Italy: IEEE
- Murray, P. (1990) 'Skidmore, Owings, Merrill - Reality before Reality'. Edizioni Tecno
- Nagel, U. (1998) 'Baustellen Management'. Berlin: Verlag für Bauwesen
- Navon [interview], interviews conducted by the author of this thesis with Navon, R., the president of the International Association for Automation and Robotics in Construction, Bratislava, June 2012
- NCC (2006) 'Annual Report 2006' [research report]. Sweden: NCC Sweden
- NCC (2012) 'Documentary Picture Set NCC Komplet' [JPEG]. Solona: NCC Communication/Press Department
- Neufert, E. (1943) 'Bauordnungslehre'. Berlin: Volk und Reich Verlag
- Nikkei BP (2009) 'Securities Report for Investors in Financial Year 2009' [website], <<http://www.nikkeibp.co.jp>> accessed 10 September 2012

- Nishimatsu (2012) 'Move Hat Implementation' [research report]. Japan: Nihimatsu Corporation
- Noever, P. (1992) 'Die Frankfurter Küche von Margarete Schütte- Lihotzky'. Berlin: Ernst & Sohn
- Norris, G.; & Wagner, M. (2010) 'Airbus A380, Superjumbo of the 21st Century'. London: Zenith Press
- NRC (1996) 'Shipbuilding Technology and Education' [research report]. Washington D.C.: National Research Council & National Academy Press
- Obayashi (1993) 'Riverside Sumida Bachelor Dormitory Documentary Video' [VHS]. Tokyo: Obayashi Corporation
- OECD (2001) 'Measuring Productivity' [research report], *OECD Manual*. Paris: Organisation for Economic Co-operation and Development (OECD)
- Ohno, T. (1978) 'Toyota Production System – beyond large scale production' (Translated by Massachusetts Productivity Press, 1988) Boston: Massachusetts Productivity Press
- Paulson, B. C. (2004) 'Machine Technology and Productivity in Construction' [lecture], Lectures at the Institut für Maschinenwesen im Baubetrieb (Institute for Machine Science in Construction) at Universität Karlsruhe (TH)
- Piller, F. T. (2006) 'Mass Customization- ein wettbewerbsstrategisches Konzept im Informationszeitalter' (4th edn). Wiesbaden: Deutsche Universitäts Verlag
- Pine, B. J.; Gilmore, J. H. (1999) 'The Experience Economy – Work is Theatre and every Business a Stage'. Boston: Harvard Business Review Press
- Plum, H.; Dornbusch, J. (2012) 'Claim-Management beim VOB-Vertrag: Abweichungen / Ansprüche / Nachträge' (2nd edn). Heinsberg: Heinz Plum Verlag
- Project Better Place [website], <<http://www.betterplace.com>> accessed 08 May 2012
- Radtke, P.; Abele, E; Zielke, A. (2004) 'Die smarte Revolution in der Automobilindustrie' [book publication based on a McKinsey research report]. Frankfurt/Wien: Wirtschaftsverlag Carl Ueberreuter
- Rehg, J. A.; Kraebber, H. W. (2005) 'Computer-Integrated Manufacturing'. Heidelberg: Springer-Verlag
- Reichwald, R.; Piller, F.T. (2009) 'Interaktive Wertschöpfung- Open Innovation, Individualisierung und neue Formen der Arbeitsteilung'. Wiesbaden: Gabler Verlag
- RIBC (2012) 'Study of Building Cost', *The Seasonal Bulletin*, 2012, No.79. Tokyo: Research Institute on Building Cost (RIBC)

- Robotus (2012) Robot Company, <<http://www.robotus.it/en>> accessed 12.12.2012
- ROS [website], Open Source Robot Operating System <<http://www.ros.org>> accessed 08.05.2012
- Ryoo, B. Y.; Chung, H. C. (2011) 'Wireless/Mobile Sensors for Monitoring Worker's Health and Safety in Construction', *Proceedings of 28th International Symposium on Automation and Robotics in Construction*, pp. 572-573. Seoul, Korea: International Association for Automation and Robotics in Construction
- Sakamoto, S.; Kumano, T. (1991) 'Research and Development of Totally Mechanized Construction System for High-rise Buildings', *Proceedings of 8th International Symposium on Automation and Robotics in Construction*, pp. 197-206. Stuttgart, Germany: International Association for Automation and Robotics in Construction
- Sakamoto, S.; Mitsuoka, H. (1994) 'Totally mechanized construction system for high-rise buildings (T-UP system) ', *Proceedings of 11th International Symposium on Automation and Robotics in Construction*, pp. 465-472. Brighton, UK: International Association for Automation and Robotics in Construction
- Sakao, T.; Lindahl, M. (2009) 'Introduction to Product/ Service-System Design'. London: Springer
- Schach, R.; Otto, J; Kochendörfer, B.; Berner, F. (2011) 'Baustelleneinrichtung: Grundlagen - Planung - Praxishinweise - Vorschriften und Regeln'. Wiesbaden: Vieweg+Teubner
- Scheer, A.-W. (1990) 'CIM Computer Integrated Manufacturing – der computergesteuerte Industriebetrieb'. Heidelberg: Springer-Verlag
- Schlee, A.; Michels, J. (1929) 'Schlackenbetonbau im Schüttverfahren: Das Bauschiff' *Bauwelt*, 1929, Volume 20, Nr. 19: 447-450
- Schmieder, M.; Thomas, S. (2005) 'Plattformstrategien und Modularisierung in der Automobilentwicklung'. Aachen: Shaker Verlag
- Sekiguchi, T.; Honama, K.; Mizutani, R.; Takagi, H. (1997) 'The Development Application of an Automatic Building Construction System Using Push-Up Machines', *Proceedings of 14th International Symposium on Automation and Robotics in Construction*, pp. 321-328. Pittsburgh, USA: International Association for Automation and Robotics in Construction
- Sekisui Heim [site visit and interview], site visit by the Author and interview with General Management, Tokyo, Japan, October 2012

- Sheldon, N. (2012) 'World's tallest skyscraper to be built with ready-made 'Meccano' pieces' [online article], < <http://www.dezeen.com/2012/10/05/chinese-company-promises-220-storey-meccano-skyscraper/>> accessed 26 Dez. 2012, London: Dezeen Architecture and Design Magazine
- Shibata, T. (1999) Study on Robotics Application for Construction Works. In: Hasegawa, T. (1999) *Robotization in Construction*, Tokyo
- Shimizu (2013) 'Documentary Picture Set Tower SMART' [JPEG]. Tokyo: Shimizu Corporation Public Relations Department
- Shimizu Desert Project Webpages [website], <<http://www.shimz.co.jp/english/theme/dream/desert.html>> accessed 26 Sept. 2012-2
- Shimizu Lunar Ring Project Webpages [website], <<http://www.shimz.co.jp/english/theme/dream/lunaring.html>> accessed 26 Sept. 2012-1
- Shimizu, 'The Tower Smart Application' [online article - Japanese website], <http://www.shimz.co.jp/news_release/2000/357.html> accessed 24 Nov. 2012
- Shingo, S. (1982) 'Study of Toyota's Production System from an engineering viewpoint' (3rd edn). Tokyo: Japan Management Association (JMA)
- Siciliano, B. and Khatib, O. (2008) 'Handbook of Robotics'. Berlin-Heidelberg: Springer
- Siciliano, B.; Sciavicco, L.; Villani, L.; Oriolo, G. (2010) 'Robotics – Modelling, Planning and Control'. London: Springer
- Siewert, U. (2012) 'Chances for Automation based on Cross-Industry Technology Transfer – Example of automotive and Aircraft Industries', *7th German Conference on Robotics* [invited talk], Munich, Germany, VDE
- Slack, N.; Chambers, S.; Johnston, R. (2009) 'Operations Management'. New Jersey: Prentice Hall International
- Slawik, H.; Bergmann, J.; Buchmeier, M.; Tinney, S. (2010) 'Container Atlas – a practical Guide to Container Architecture'. Berlin: Die Gestalten Verlag
- Smart GmbH (2008) 'Smart, smart car, big deal'. Minneapolis: Motorbooks MBI Publishing Company
- Son, H.; Kim, C. (2010) '3D Structural Component Recognition and Modeling Method Using Color and 3D Data for Construction Progress Monitoring', *Automation in Construction*, Vol. 19, 7: 844-854
- Spicknall, M. H. (2003) 'The shipbuilding process', *Ship Design & Construction*, Vol. 1. New Jersey: Society of Naval Architects and Engineers.

- Stevenson, N. (1998) 'Meisterwerke der Architektur'. Cologne: DuMont
- Sundín, E. (2009) 'Life-Cycle Perspectives of Product Service Systems'. In Sakao, T.; Lindahl, M. (2009) *Introduction to Product/Service-System Design*, London: Springer-Verlag
- Tani, Y.; Nakano, M.; Okoshi, M.; Maeda, S.; Isa, H. (1996) 'Research and Development of Automatic System for Open Caisson Method', *Proceedings of 13th International Symposium on Automation and Robotics in Construction*, pp. 323-332. Tokyo, Japan: International Association for Automation and Robotics in Construction, ,
- Tapscott, D.; Williams, A. D. (2010) 'Macrowikinomics – Rebooting Business and the World' New York: Portfolio Penguin
- Taylor, F. W. (1911) 'The Principles of Scientific Managemenet' (Reprinted 2010). New York: Cosimo Classics
- Thiesen, W. H. (2006) 'Industrializing American Shipbuilding – The Transformation of Ship Design and Construction, 1820-1920'. Florida: University Press of Florida
- Thomas, H. R.; Sakarcn, A. (1994) 'Forecasting labor productivity using factor model', *Journal of Construction Engineering and Management*, Vol. 120, 1: 228-239
- Thomas, R. (1992) 'Effects of scheduled overtime on labor productivity', *Journal of Construction Engineering and Management*, VOL. 118, 1: 60-70
- Tidd, J.; Bessant, J. (2009) 'Managing Innovation – Integrating Technological, Market and Organizational Change'. Sussex: John Wiley & Sons
- Toyota [site visit], site visit by the author to the Toyota Motors Main Plant, Aichi Prefecture, Japan, December 2011
- Traub, J. F.; Werschulz, A. G. (1999) 'Complexity and Information'. Cambridge: Cambridge University Press
- U.S. Department of Labor (2012) 'Workplace Safety and Health Statistics' [research report]. Washington DC: United States Department of Labor/U.S. Bureau of Labor Statistics
- Ueno, T. (1998) 'Automation and Robotics in Construction in Japan – State of the Art'. *Proceedings of 15th International Symposium on Automation and Robotics in Construction*, (Ed.) pp. 33-36. Munich, Germany: International Association for Automation and Robotics in Construction
- United Nations Indicators of Sustainable Development (2012) [website], <www.un.org> accessed 06 May 2012
- USGS (1998) 'Materials Flow and Sustainability' [research report], *Fact Sheet FS-068-98*. U.S. Department of Interior, U.S. Geological Survey

- Vepa, R. (2009) 'Biomimetic Robotics – Mechanisms and Control'. Cambridge: Cambridge University Press
- Wakisaka, T.; Furuya, N.; Hishikawa, K.; Inoue, Y.; Shiokawa, T.; Yoshino, K.; Hamada, K.; Inoue, F.; Kurita, K. (1997) 'Automated Construction System for High-rise Reinforced Concrete Buildings', *Proceedings of 14th International Symposium on Automation and Robotics in Construction*, pp. 111-118. Pittsburgh, USA: International Association for Automation and Robotics in Construction,
- Weller, K. (1986) 'Industrielles Bauen 1'. Stuttgart: Verlag W. Kohlhammer
- Westerholm, T. (2009) 'Stylemachine - Mass tailored Apartments'. In: Suominen, J., I.; Piller, F. T.; Tseng, M., (eds): *Proceedings of The 5th International Conference on Mass Customization and Personalization*, Helsinki, Finland: MCPC 2009
- Williams, M.; Farnie, D.A. (1992) 'Cotton Mills in Greater Manchester'. Lancaster: Carnegie Publishing
- Willis, R. (1841) 'Principles of Mechanism'. Cambridge: Cambridge University Press (Digital Reprint in 2010)
- Wimmer, R. (2009) 'Strategieentwicklung für eine industrielle Serienfertigung ökologischer Passivhäuser' [research report], *Bericht aus Energie und Umweltforschung*. Vienna: Bundesministerium für Verkehr, Innovation und Technologie
- Wißnet, A. (2007) 'Roboter in Japan: Ursachen und Hintergründe eines Phänomens'. Munich: Iudicium-Verlag
- Wöhe, G. (2010) 'Einführung in die allgemeine Betriebswirtschaftslehre' Munich: Verlag Franz Vahlen
- Wood, B. (2009) 'Building Maintenance'. Singapore: Wiley-Blackwell
- World Robotics Report (2012) 'Industrial Robots & Service Robots' [research report], *Market Statistics Report*, World Robotics & VDMA
- Xerox (2012) 'Xerox Waste Prevention' [online article], <<http://www.xerox.com/corporate-citizenship-2009/xerox-report/waste-prevention.html>> accessed 06 May 2012
- Yatsuka, H.; Kikuchi, M.; Yoshiuki, Y.; and others (2011) 'Metabolism – The City of the Future'. Tokyo: Mori Art Museum & Shinkenchiku-sha
- Yenne, B. (2010) 'The American Aircraft Factory in World War II'. Minneapolis: Zenith Press

- Yoshida, N.; Kanagawa, T.; Tani, Y.; Oda, Y. (1997) 'Development of an Automatic-oriented Sheltered Building Construction System', *Proceedings of 14th International Symposium on Automation and Robotics in Construction*, pp. 129-138. Pittsburgh, USA: International Association for Automation and Robotics in Construction,
- Zäh, M. F.; Beetz, M.; Shea, K.; Reinhardt, G.; Bender, K.; Lau, C.; Ostgathe, M.; Vogl, W.; Wiesbeck, M.; Engelhardt, M.; Ertelt, C.; Rühr, T.; Friedrich, M.; Herle, S. (2009) 'The Cognitive Factory'. In: ElMaraghy, H. A. (2009) 'Changeable and Reconfigurable Manufacturing Systems'. London: Springer
- Züblin (2003) 'Bauforschung-Bautechnik' [research report]. Königswinter: German Federal Ministry of Science and Research