

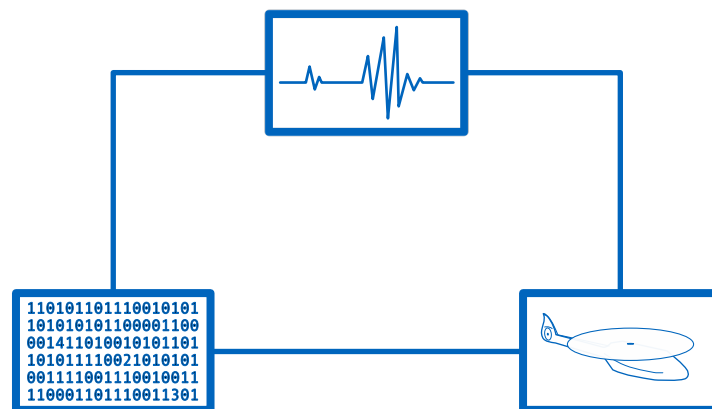

Automated evaluation of non-destructive testing situations using a generic model



Michael Dominik Alfred Mosch

Vollständiger Abdruck der von der Fakultät für Maschinenwesen der Technischen Universität München zur Erlangung des akademischen Grades eines

Doktor-Ingenieurs (Dr.-Ing.)

genehmigten Dissertation.



Fakultät für Maschinenwesen

Automated evaluation of non-destructive testing situations using a generic model

Michael Dominik Alfred Mosch

Vollständiger Abdruck der von der Fakultät für Maschinenwesen der Technischen Universität München zur Erlangung des akademischen Grades eines

Doktor-Ingenieurs (Dr.-Ing.)

genehmigten Dissertation.

Vorsitzender: Prof. Phaedon-Stelios Koutsourelakis, Ph.D.

Prüfende der Dissertation:

1. Prof. Dr.-Ing. habil. Christian U. Große
2. Prof. Dr.-Ing. Manfred Hajek

Die Dissertation wurde am 29.10.2020 bei der Technischen Universität München eingereicht und durch die Fakultät für Maschinenwesen am 10.03.2021 angenommen.

Inhaltsverzeichnis

I. Introduction	3
1. Introduction and Motivation	4
II. Theoretical Considerations	8
2. Theoretical Background	9
2.1. Context about Non Destructive Testing	9
2.1.1. Limits and possibilities of NDT methods	9
2.1.2. Methods used in examples	11
2.1.2.1. Ultrasonic inspection	11
2.1.2.2. Radiographic inspection	15
2.2. Theory of computation	20
2.2.1. Models, Computability and Turing machine	20
2.2.2. Formal Languages	21
2.2.3. Languages, automates and computation time	23
2.2.4. Model building	25
2.3. Data storage and data access	25
2.4. Procedure models and processes in product development and production .	28
3. Situation analysis of Non Destructive Testing	32
3.1. Purpose and context of NDT	32
3.1.1. Possibilities and expectations for non-destructive testing	33
3.1.2. Requirements of non-destructive testing	33
3.1.3. Special needs of serial production regarding NDT	34
3.1.4. Inspection data analysis and storage	34
3.2. Input and boundary conditions on NDT inspections	34
3.3. NDT in the overall process	36
3.3.1. Analysis of overall development and production process of a heli- copter tail boom	37
3.3.2. Interfaces between testing and other faculties in the overall process	38
3.3.3. Expectation and situation of NDT in the overall process	42
4. The Generic Model - Automated evaluation of test situations	44
4.1. Requirements for the Generic Model	44

Inhaltsverzeichnis

4.2.	A formal language to describe test situations	44
4.2.1.	Formal description of geometry	48
4.2.1.1.	Description of an element with connected nodes	48
4.2.1.2.	Describing a geometry in three dimensional orientation and switch to finite elements	51
4.2.1.3.	Description parameters for finite geometry elements	53
4.2.2.	Formal description of an anomaly	54
4.2.2.1.	Description of the anomaly geometry	55
4.2.2.2.	Description of the anomaly effect	55
4.2.3.	Formal description of the test methods	57
4.2.3.1.	Nomenclature to address a test method	57
4.2.3.2.	Performance comparison of test methods	58
4.2.4.	A formal language to describe geometry, anomaly and test method	60
4.3.	Use of the formal language in the Generic Model	62
4.3.1.	Example of how to use the Generic Model	64
4.4.	The Generic Model	66
4.4.1.	System boundaries	67
4.4.2.	Input and output of the Generic Model	68
4.4.3.	Sub-Systems	68
4.4.4.	Model behavior	69
4.5.	Principle of automated evaluation	69
4.5.1.	Example: Curvature analysis of Component	69
4.6.	Summary of chapter 4	70
5.	NDT as additional degree of freedom during the design process	85
5.1.	Requirement profile and constraint analysis of a part	85
5.1.1.	Link with product development	85
5.1.2.	Constraint analysis on an example at Airbus Helicopters Deutsch- land GmbH	86
5.2.	Design optimization of a part	86
5.2.1.	IPro - upper deck of an helicopter	86
5.2.2.	Example: optimization of a structural part.	87
5.3.	Summary	88
6.	Characterization of the relation between origin and effect of an anomaly	93
6.1.	Origin and Effect	93
6.2.	Effect of Defect (EoD)	94
6.3.	Avoidance of Defect (AoD)	96
6.4.	Summary	98

III. Software Implementation	99
7. Thoughts on implementing the Generic Model into a software tool	100
7.1. Requirements	100
7.2. Possible software structure	101
7.3. Implementation suggestion	102
7.4. Input and Output of the software	102
7.5. Summary	104
IV. Conclusions and Outlook	105
8. Summary and Conclusions	106
9. Outlook	108
10. Acknowledgment	110
11. List of Publications	111
A. Appendix	XII
A.1. NDT in the overall process - interviews	XII
A.2. Comparison of a non-optimized and an optimized part	XVIII

List of abbreviations

CAD:	Computer Aided Design
CCD:	Charge-coupled Device
CFRP:	Carbon fiber reinforced plastic
CS:	Certification Specification
DLR:	<i>German:</i> Deutsches Zentrum für Luft und Raumfahrt, German Aerospace Center
EASA:	European Union Aviation Safety Agency
FAL:	Final Assembly Line
HiDEF:	LuFo IV-Projekt - Fehlererkennung bei der Harzinfusionstechnologie
MAI ZfP:	Research project 01.03.2013 - 29.02.2016 embedded in MAI Carbon research project
MCT:	Micro Computer Tomography
NBUS:	Narrowband Ultrasonic Spectroscopy
NDT:	Non Destructive Testing
OLT:	Lock-in Thermographie
POD:	Probability of Detecting
QM:	Quality Management
UT:	Ultrasonic Testing
VDI:	<i>German:</i> Verein Deutscher Ingenieure e.V., The Association of German Engineers
VT:	Visual Testing
ZfP:	<i>German:</i> Zerstörungsfreie Prüfung, Non Destructive Testing

Abstract

One big challenge in aeronautics is the combination of lightweight structures with a maximum of flight safety. Highly optimized structures and extensive quality assurance with NDT methods are one possibility to address this objective. However, the needs of NDT with respect to testability are often not considered during the design process of a structure or a part. This can lead to high inspection costs or even the need to redesign the part. The generic model addresses this issue by bringing the requirements of NDT not as limits, but as an optimization possibility into the early design process.

This thesis starts with a situation analysis of NDT in the overall development and production process in order to understand the requirements needed in each step of this process. Based on this analysis, a formal language is developed. This language is able to describe a test situation and leads to a Generic Model, which describes the influences on NDT as well as its requirements. The model consists of two major parts. A static part to describe a test situation and a functional part that shows the interaction of the static elements. Beginning with a single characteristic comparison, an example will show how to evaluate the testability of a complete part on different aspects of NDT. It is shown how an automated evaluation can be realized and a software tool to implement this procedure into the development process is proposed. The goal is improvement of part design, reducing iterations in the design process and increase testability by NDT.

Kurzzusammenfassung

Eine große Herausforderung in der Luftfahrt ist die Kombination von Leichtbaustrukturen mit einem Maximum an Flugsicherheit. Hochoptimierte Strukturen und eine umfassende Qualitätssicherung mit ZfP-Methoden sind eine Möglichkeit, dieses Ziel zu erreichen. Allerdings werden die Anforderungen der ZfP hinsichtlich der Prüfbarkeit beim Entwurfsprozess einer Struktur oder eines Teils oft nicht berücksichtigt. Dies kann zu hohen Prüfkosten oder sogar zur Notwendigkeit einer Neukonstruktion des Bauteils führen. Das generische Modell löst dieses Problem, indem es die Anforderungen der ZfP nicht als Grenzwerte, sondern als Optimierungsmöglichkeit in den frühen Entwurfsprozess einbringt.

Diese Arbeit beginnt mit einer Situationsanalyse der ZfP im gesamten Entwicklungs- und Produktionsprozess, um die in jedem Schritt dieses Prozesses benötigten Anforderungen zu verstehen. Basierend auf dieser Analyse wird eine formale Sprache entwickelt. Diese Sprache ist in der Lage, eine Prüfsituation zu beschreiben und führt im Folgenden zu einem generischen Modell, das die Einflüsse auf die ZfP sowie deren Anforderungen beschreibt. Das Modell besteht aus zwei Hauptteilen. Einem statischen Teil zur Beschreibung einer Testsituation und einem funktionalen Teil, der das Zusammenspiel der statischen Elemente zeigt. Ausgehend von einem einzelnen Merkmalsvergleich wird an einem Beispiel gezeigt, wie die Prüfbarkeit eines kompletten Teils zu verschiedenen Aspekten der ZfP bewertet werden kann. Es wird gezeigt, wie eine automatisierte Auswertung realisiert werden kann und eine Software zur Implementierung dieses Verfahrens in den Entwicklungsprozess vorgeschlagen. Das Ziel ist die Verbesserung des Teiledesigns, die Reduzierung von Iterationen im Designprozess und die Erhöhung der Testbarkeit durch ZfP.

Part I.

Introduction

1. Introduction and Motivation

During the history of industrialization as well as today, product development puts an engineer or developer in an area of conflicts such as better performance and reliability at lower costs. Each era has its excitement about a new technology, but also its setbacks. Any incident, such as an aircraft crash, has a great impact on how technology is accepted. One consequence of such a tragedy is the thorough investigation into the root cause of the accident and an implementation of a strategy to avoid future problems. In the past, this led to extensive qualifications and quality assurance procedures during the development and production of any kind of product, especially in aeronautics (EASA, 2013). Flight safety is the first key value to all developments in aeronautics and can lead up to a full inspection of every delivered part (Oster, 2012). Non Destructive Testing (NDT) therefore also has a great responsibility in ensuring flight safety.

Looking back, the history of modern NDT started with the examinations of pressure tanks and railroad constructions. The goal of these tests was, firstly, the prevention of accidents and ensuring reliability of the parts and secondly to ensure the quality control of construction materials (Krankenhagen et al., 1979; Krüger & Weeber, 1983). Quality is, by definition, the degree to which a set of inherent characteristics of an object fulfills requirements (EN 9000 DIN-EN-ISO, 2015). The production cycle of a part starts with the definition of requirements. Based on these requirements, a product is designed by taking all the different constraints, such as material, production options or costs, into account. After the fabrication of a product, the fulfillment of these requirements has to be ensured (figure 1.1) (VDI, 1993). With this, we have come full circle, as NDT is one of the important methods for this quality assurance. An inspection can determine if set limits are being exceeded or not and according action can be taken. If a limit is overstepped, the "Effect of Defect" has to be evaluated in order to decide further use of the inspected part (Oster, 2012). From this process constellation, where NDT results function as acceptance criteria for production parts, arises a great potential for conflicts between people in development and production environments. It is mandatory to consider this human factor and combine it with the discussion of technical issues.

1. Introduction and Motivation

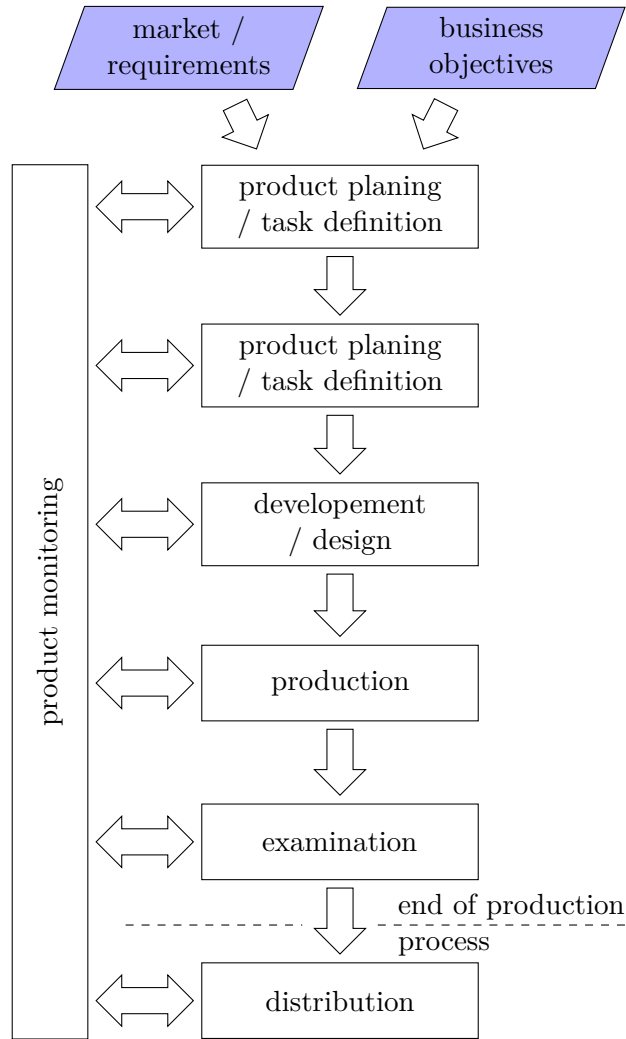

Figure 1.1.: Production process with examination at the end. To create a product, a development process is triggered by market and business requirements and implements planning, production and examination steps. Based on VDI 2221 (VDI, 1993).

Besides flight safety and requirement fulfillment, an optimal efficiently structured part design is of great interest and has influence on the inspection situation. This applies to all industries, especially to aeronautics with a big focus in lightweight components and structures. Parts are optimized in shape and material to increase their performance. Carbon fiber reinforced plastics (CFRP) are widely used to reduce the weight of aircrafts. However, in contrast to classically produced metallic parts, CFRP has a disadvantage concerning testability. There is no pre-product with an easy geometry to inspect, just the final part. A “classic” metallic structure, for example, can be inspected as a block before milling, which is not possible for CFRP. Furthermore, for the ideal

1. Introduction and Motivation

application of fiber materials, fibers are placed load optimized leading to parts with flowing lines and thickness changes. Similar problems arise with other technologies such as additive manufacturing. This increases the complexity of an inspection or can make testing impossible. Those difficulties would lead to a lower significance for the test and a requirement for higher safety margins, increasing the rejection rate for any part in production or lead to heavier parts in order to keep rejection rates low. Especially in serial production, a complex inspection is not an option. However, this can also be seen as chance to use the constraints given by NDT to get the maximum performance out of a material, element or part, by considering these limits in the design process and arranging for easy testability. How this can be achieved will be the main topic of this work. Very often, this approach is described as design to NDT. Until now this approach is not very focused or structured and relies often on personal interaction rather than on an organized process with multiple problems. In fact, there are many opportunities to ease integration of NDT into the early design process (Schmiedel & Holzheimer, 2016). Not considering the requirements of quality assurance might increase development costs and end up in time delays due to a variety of effects. One example are the direct costs of examination as a result of unnecessary complex test scenarios. A part with unfavorable geometry causes increased test effort and therefore higher costs and longer test time. In a worst-case scenario, an impossible test leads to redesign and correspondingly to a significant time delay. One reason for this lack of close linkage between construction and testing is the absence of a common language able to discuss anomalies, the effect of defect and non-destructive testing itself. There is a need for clear definitions of factors such as anomalies, effects, geometry or signals that are applicable for design and stress division as well as for production and testing faculties. To gain better acceptance and integration of NDT in construction, design process and development and to avoid complex testing situations, it is important to introduce NDT as an opportunity and not as a limitation. The close link might lead to an optimized design based on excellent use of NDT at lower cost and weight. Therefore, this common language has to be developed and a standardization process has to be started.

In this research, a *Generic Model* is developed with the objective to connect development and inspection requirements. It will be based on a formal language that allows the unambiguous description of a *Test Situation* and is also basis for communication between different faculties. To accomplish this goal, a situation analysis of NDT, followed by an elaboration of the requirements for an inspection will be performed. This will be input for the formal language and the *Generic Model*. Several examples and practical consideration position the model into a real world context. The utilization of the *Generic Model* in an industrial environment is discussed by means of recommendation for a software implementation leading the way to its execution.

The basic ideas for this work emerged from concrete problems of non-destructive testing at *Airbus Helicopters* in Donauwörth, Germany. Accordingly, many details of this work are described from the perspective of aviation. However, the solution approaches were discussed with NDT experts from various industries within the framework of the MAIZfP project (Sause et al., 2016; Grosse et al., 2016), including the automotive industry, and extended accordingly. This means, that even the examples and motivation are

1. Introduction and Motivation

triggered by the aviation industry, all results are applicable to other industries. As there might also be a shift in material and production constraints, the optimization aspect might be even more interesting: Aeronautics is dominated by low production quantity, lightweight materials and a lot of manual work, other industries in comparison face high production rates, a high automation level and are more sensitive to cost per part. With the use of CFRP in these industries, a high interest in test optimization can be expected.

Part II.

Theoretical Considerations

2. Theoretical Background

This research about the *Generic Model* and its implementation connects several topics from different disciplines. Therefore it does not build up on one related subject but has to follow several foundations. There is NDT as starting point and motivation which also defines the basic rules for the model. To put these constraints into context, tools and methods from computer science are used. The formal definitions about languages and data models are essential for the later work. Input about production processes and methods to handle this complexity is based on information of research faculties of product development. It is used as an orientation and justification for the *Generic Model* to be developed.

2.1. Context about Non Destructive Testing

As pointed out in the introduction, one task of NDT is to ensure the fulfillment of requirements after part production (figure 1.1) and detect deviations. These deviations are referred to as anomalies or imperfections. In this context, NDT is an important part of the quality process within a company and has to cover a wide field of different test scenarios.

2.1.1. Limits and possibilities of NDT methods

One fundamental element of this work are the limitations and possibilities of NDT inspection methods. This paragraph will give an overview about the definition and reasons of constraints.

A huge variety of different NDT methods is described in literature (Beine et al., 2010; Bogue, 2012; Duchene et al., 2018; Vary, 1973). The focus of this work is mainly on NDT methods best suited for CFRP but the fundamental thoughts are applicable to inspection methods in general. As shown in table 2.1, Vary (1973) classifies these methods into different categories. Another approach could be the classification based on the three physical wave category of excitation and detection: Mechanical, thermal and electro-magnetical energy is used in different ways to gain information about inner characteristics of a part. Reduced to this physical quantity, it is obvious, that different methods interact in different ways with different materials or with different parts that have to be inspected. Therefore the various methods have advantages or disadvantages depending on the situation and the inspected part. The aim of the *Generic Model* will be the characterization of these limits and possibilities relative to the test situation and a possible anomaly that has to be detected.

2. Theoretical Background

Categories	Objectives
BASIC CATEGORIES	
Mechanical-optical	Color; Crack; Dimensions; Film thickness; Gauging; Reflectivity; Strain distribution and magnitude; Surface finish; Surface flaws; Through cracks
Penetration radiation	Bond separation; Cracks; Density; Density and chemistry variations; Elemental distribution; Foreign objects; Inclusions; Microporosity; Misalignment; Missing Electromagnetic - electronic Sonic-ultrasonic Thermal Chemical-analytical Image generation parts; Segregation; Shrinkage; Thickness; Voids
Electromagnetic-electronic	Alloy content; Anisotropy; Cavities; Cold work, Local strain, Hardness; Composition; Contamination; Corrosion; Cracks; Crack depth; Crystal structure; Electrical and thermal conductivity, Flakes; Heat treat; Hot tears; Inclusions; Ion concentrations; Laps; Lattice strain; Layer thickness; Moisture content; Polarization; Seams; Segregation; Shrinkage; State of cure; Tensile strength; Thickness; Unbonds
Sonic-ultrasonic	Crack initiation and propagation; Cracks, Voids; Damping factor; Degree of cure; Degree of impregnation; Degree of sintering, Delaminations; Density; Dimensions; Elastic moduli; Grain size; Inclusions; Mechanical degradation; Misalignment; Porosity; Radiation degradation; Structure of composites; Surface stress; Tensile, shear and compressive strength; Unbonds; Wear
Thermal	Bonding; Composition; Emissivity; Heat contours; Plating thickness; Porosity; Reflectivity; Stress; Thermal conductivity; Thickness; Voids
Chemical-analytical	Alloy identification; Composition; Cracks; Elemental analysis and distribution; Grain size; Inclusions; Macrostructure; Porosity; Segregation; Surface flaws
AUXILIARY CATEGORIES	
Image generation	Dimensional variations; Dynamic performance; Flaw characterization and definition; Flaw distribution; Flaw propagation; Magnetic field configurations
Signal-image analysis	Data selection, processing, and presentation; Flaw mapping, correlation, and identification; Image enhancement; Separation of multiple variables; Signature analysis

Table 2.1.: Categories of different NDT methods and detectable anomalies according to Vary (1973). To each NDT category, types of possibly detectable anomalies are listed. This does not mean that all listed anomalies can always be found with the method, but it shows which test method reacts to which (physical) effect.

2. Theoretical Background

2.1.2. Methods used in examples

As the model presented later claims to be generic, it is independent of a specific method, geometry or anomaly. However, in order to evaluate this strategy in examples, the NDT methods *ultrasonic inspection* and *radiographic* or *computer tomography inspection* will be explained in more detail.

2.1.2.1. Ultrasonic inspection

In this chapter, relevant basics will be explained, followed by a description of the measurement using the pulse-echo ultrasonic method. Here, measurements are considered in contact mode. For an application using air coupled ultrasound, (Stoessel, 2003) is recommended for further reading.

The basic idea of one-sided ultrasonic testing (pulse-echo) is based on the emission of an ultrasonic pulse and the interpretation of the signal response with respect to attenuation and propagation time (figure 2.1). The most important material parameter for sound propagation and thus for ultrasonic examination is the *specific acoustic impedance* Z (Vogt et al., 1997):

$$Z = \rho * c \quad (2.1)$$

with:

Z : specific acoustic impedance $\left[\frac{kg}{m^2s}\right]$

ρ : material density

c : Speed of sound in the selected material

A comparison to electricity can be drawn: The specific acoustic impedance is also referred to as the sound wave impedance. While current flow and voltage are linked to the electrical resistance, there is a corresponding relationship between the velocity of the moving particles and the sound pressure p . In both cases, energy is transported. The acoustic energy passing through a surface per time is called intensity I (Vogt et al., 1997):

$$I = \frac{p}{2Z} \quad (2.2)$$

with:

I : intensity $\left[\frac{W}{m^2}\right]$

p : sound pressure $\left[\frac{N}{m^2}\right]$

Usually the sound pressure is not given in absolute terms but as sound pressure level L related to a reference value p_0 (Vogt et al., 1997):

$$L [dB] = 20 * lg \frac{p}{p_0} \quad (2.3)$$

2. Theoretical Background

The intensity and thus the sound pressure level becomes relevant when considering whether the energy used is sufficient to penetrate the sample. For the actual measurement, this means that the energy must be adjusted accordingly in order to obtain a usable signal response.

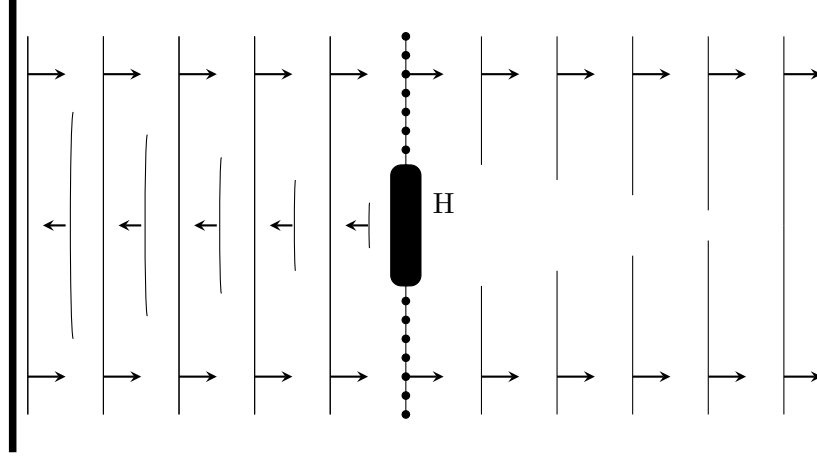

Figure 2.1.: Reflection and diffraction of a wave at an obstacle H. Based on Vogt et al. (1997).

As mentioned before, the interpretation of the response signal to the excitation is relevant for the measurement. In the one-sided measurement, it is therefore important which part of the signal is reflected by an inhomogeneity, whereas in the case of transmission the transmitted part is considered. In vertical sound exposure, part of the sound pressure p_E is reflected vertically ($R \cdot p_E$) and another part ($T \cdot p_E$) is let through (figure 2.2). Relevant for the reflection factor R and the transmission factor T are the acoustic impedances Z_i of the adjacent media Vogt et al. 1997:

$$R = \frac{Z_2 - Z_1}{Z_2 + Z_1} \quad (2.4)$$

$$T = \frac{2Z_2}{Z_2 + Z_1} \quad (2.5)$$

It is assumed that the surfaces are smooth in relation to the wavelength and the inducer is perpendicular to the surface.

2. Theoretical Background

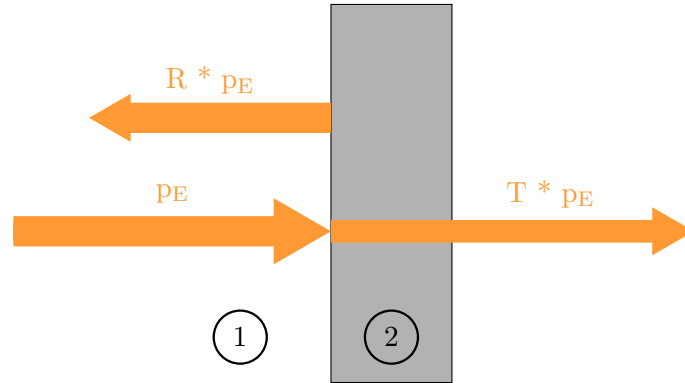

Figure 2.2.: Vertical impact of a sound wave on the interface of the media (1) and (2). Part of the sound is reflected and another part is transmitted. For reasons of simplification further effects are ignored, however it is important to be aware of $p_E \neq R * p_E + T * p_E$.

Effects and techniques such as piezo crystals, magnetostriction, lasers or electrodynamic ultrasound generation can be used to generate the excitation signal (Vogt et al., 1997). For example, a piezo changes its expansion by applying a voltage. If the voltage is applied at a certain frequency, a membrane can be excited and a sound field is created (Vogt et al., 1997). However, without going into the excitation further, the sound radiation and the resulting sound field are of interest. According to Huygen's principle, each point on the radiating surface is seen as the source of a spherical wave. The sound field is therefore the superposition of these elementary waves. As shown in figure 2.3 the so-called near field with strongly varying sound pressure must be considered (Vogt et al., 1997).

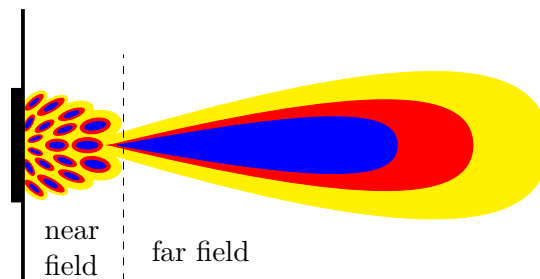

Figure 2.3.: Sound pressure of a circular radiating surface schematically represented as two-dimensional cut (Based on Vogt et al. (1997)). The subdivision between near field and far field is marked. The darker colors correspond to a higher sound pressure level. For UT inspection, the near field has to be outside of the inspected part. This can be realized by using a transducer wedge.

As already described at the beginning of this paragraph and shown in figure 2.1, the interpretation of the response signal to an excitation is relevant for the one-sided mea-

2. Theoretical Background

surement. With the pulse-echo method, a short signal pulse is transmitted accordingly and the time until its re-entry is evaluated. In figure 2.4 a sound field emitted by transmitter P to the sample is compared with the temporally received response signal. An inlet signal and a back-wall echo shall be determined on a homogeneous, flawless sample. For homogeneous materials, than the time between the input signal S and the back-wall echo results from the sound velocity c and the component thickness d to $t = \frac{2d}{c}$. If a defect is partially in the sound field, an error signal F is to be observed before the back wall signal R accordingly. In the case of large defects, the back-wall echo can also fail completely (back-wall echo failure). In both cases, the relative depth position Δd of the error can now be concluded due to the transit time:

$$\Delta d = \frac{tc}{2} \quad (2.6)$$

As the previous considerations show, the method is not directly dependent on the frequency used. However, the frequency must be observed for the minimum error size to be detected. Thus, the theoretically smallest detectable error with the edge length a depends on the wavelength λ . Depending on environmental influences, a minimum error size of $a = \frac{\lambda}{2}$ is therefore still considered detectable (Vogt et al., 1997). Even if high frequencies are available, it must be taken into account that these respond to normal inhomogeneities of the material. Furthermore, more sound pressure can be built up at lower frequencies during the technical implementation of the probes due to mass inertia.

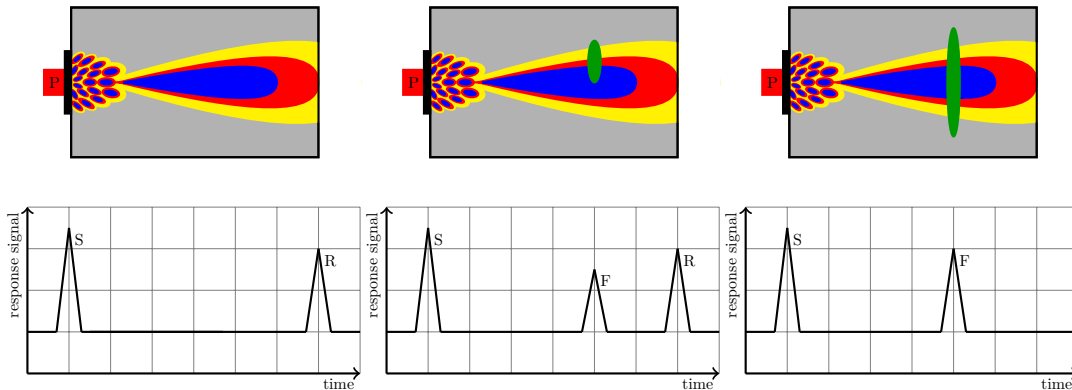

Figure 2.4.: The sound field generated by transmitter P is compared to the response signal applied over time. A distinction must be made between the input signal S, the backwall echo R and the fault echo F. If an anomaly blocks the complete path, no backwall echo is received.

When viewing the measurement results of an ultrasound examination, a distinction is first made between the result images A, B, C and D shown in figure 2.5. The time plotted amplitude image, which is explained in 2.4, is called an *A-scan*. Thus, for each point p_{xy} a separate A-scan results during the tomographic test of an area. The B-scan is a section through the component along the line on which the probe is moved in the xy-direction, in which the amplitude and propagation time of the signal are displayed.

2. Theoretical Background

Accordingly, the C-scan is a plan view of the component, in which the amplitudes of the signal are then displayed. Using the echo travel time instead of the echo amplitude is called a D-scan instead of a C-scan (Vogt et al., 1997). A D-scan can give information about materials with different sound velocity. Thus, B-scan and C-scan (D-scan) are each a projection of the error echoes of all measured points p_{xy} on the xz plane and on the xy plane. By means of the B, C and D images, a defect in a component can thus be detected very quickly by viewing it.

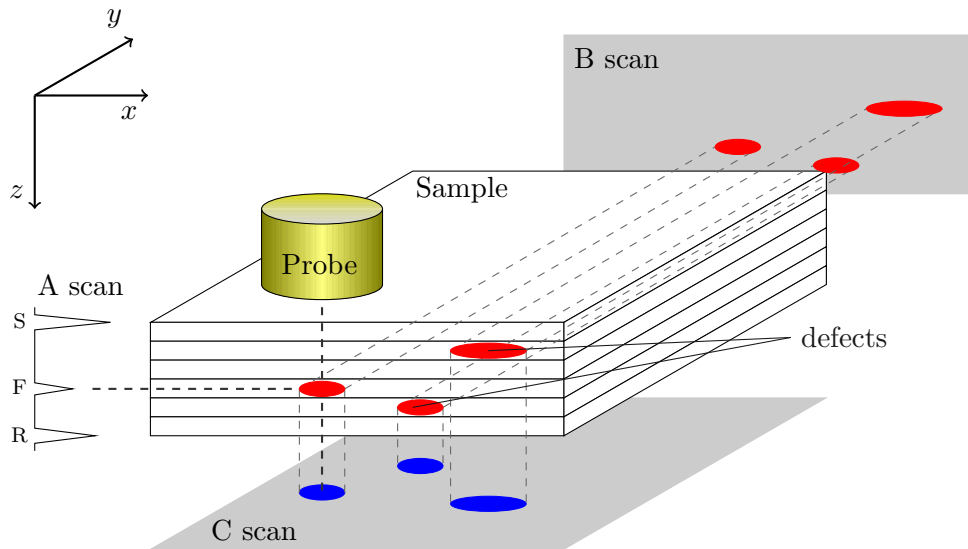

Figure 2.5.: Correlation of the various result displays for ultrasonic measurements. The A scan is a direct result of the echo as shown in figure 2.4. Mapping this information on a plane results in the C scan (x - y plane) or B scan (x - z plane).

2.1.2.2. Radiographic inspection

Radiographic inspection is based on the use of X-rays (Röntgen, 1895). X-rays are generated by two mechanisms with different emission spectrums. By firing electrons at a "target" element A (figure 2.6), Bremsstrahlung (braking radiation) is released due to the strong electron deceleration. This mechanism generates a continuous radiation spectrum. In addition, the accelerated electrons "knock out" other electrons of the target atoms from their orbitals near the nucleus. This is compensated by moving electrons along outer orbits. As a result X-ray quanta are emitted with a corresponding energy (Krohn, 2002) which results in a discrete radiation spectrum. By means of suitable radiation angles, a targeted irradiation of an object can thus take place. An analog or digital detector is used to visualize the inner features of the screened object (figure 2.7).

If an emitted wave hits an obstacle that hinders its linear propagation, its direction of propagation is changed. This is done according to Huygen's principle by seeing each point on a phase surface of the wave as the starting point of a new wave. These waves

2. Theoretical Background

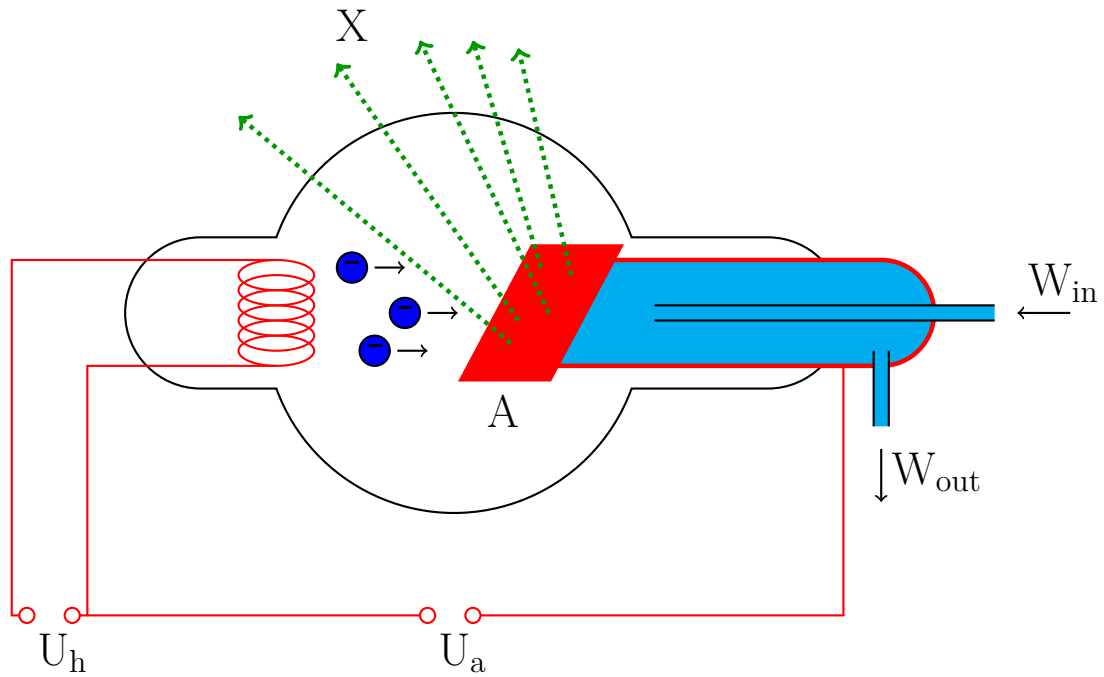

Figure 2.6.: Schematic drawing of an X-ray tube. It produces X-rays by impinging electrons to target area A by using heat voltage U_h and acceleration voltage U_a . To handle thermal issues a cooling liquid W might be used. Based on HMilch (2008).

2. Theoretical Background

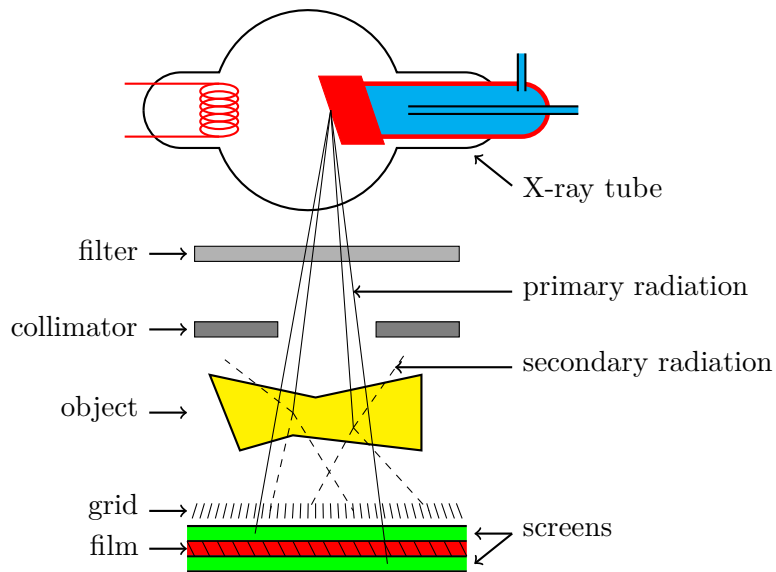

Figure 2.7.: Principle setup of an X-ray examination. From the X-ray tube emitted primary radiation is directed towards an object. Depending on the object's density and the radiating length, the intensity of the primary radiation on the film varies. This produces the typically grey image of an X-ray inspection. A grid that is aligned with the primary X-rays, reduces disturbances of secondary radiation.

2. Theoretical Background

spread in all directions and overlay each other and now again form the phase surface of the original wave. An obstacle changes this, so that, for example, a gap becomes the source of a wave now spreading in a circle Demtröder, 2005. If a wave hits a medium in which the wave has a different propagation speed, a part is reflected and a part transmitted with a change of direction Demtröder 2005. The change of direction shown in Figure 2.8 can be described by Snellius' law of refraction (Born, 1965):

$$\frac{\sin\alpha}{c_1} = \frac{\sin\beta}{c_2} \quad (2.7)$$

$$n_{12} = \frac{\sin\alpha}{\sin\beta} = \frac{c_1}{c_2} \quad (2.8)$$

with

c_1 : velocity of wave propagation in medium n_1

c_2 : velocity of wave propagation in medium n_2

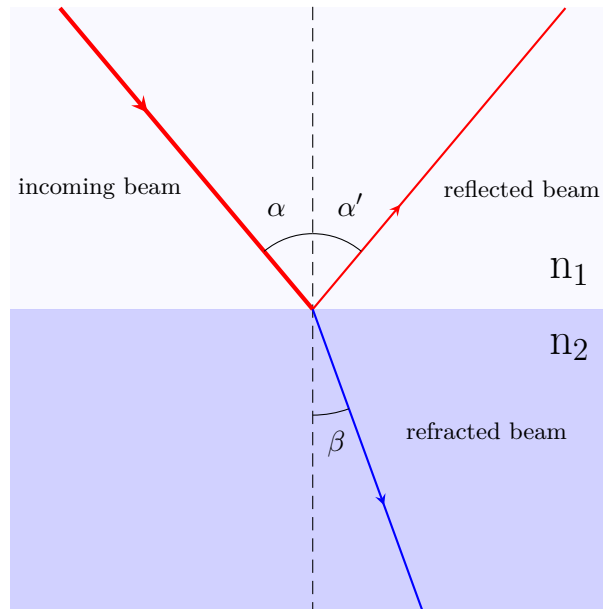

Figure 2.8.: Refraction and reflection of a wave at an interface according to Snell's law. The refractive index n_i of the material describes the velocity of light inside the medium i in relation to the velocity of the light in vacuum.

The ratio n_{12} is referred to as refractive index. In a simplified assumption, according to Maxwell (Born, 1965), the transition from vacuum to medium applies:

$$n = \sqrt{\frac{\varepsilon}{\mu}} \quad (2.9)$$

2. Theoretical Background

with:

ε : Permittivity (electrical conductivity)

μ : Permeability (magnetic conductivity)

With its equation Sellmeier (1871) provides the missing correlation between the wavelength λ of the radiation and material constants, which are to be determined experimentally:

$$n^2(\lambda) = 1 + \frac{B_1\lambda^2}{\lambda^2 - C_1} + \frac{B_2\lambda^2}{\lambda^2 - C_2} + \frac{B_3\lambda^2}{\lambda^2 - C_3} \quad (2.10)$$

with:

B_n : dimensionless coefficient

C_n : coefficient in m^2 , usually in specified in μm^2

In the next step, Fresnel's formulae are used to define the reflection coefficient R or transmission coefficient T in relation of the refractive indexes n_i of the respective media (Born, 1965):

$$R = \frac{n_1 - n_2}{n_1 + n_2} \quad (2.11)$$

$$T = \frac{2n_1}{n_1 + n_2} \quad (2.12)$$

To describe the behavior of an electromagnetic wave completely, the characteristic impedance is now introduced (without further explanation) (Born, 1965). It can be seen as resistance of a material against electromagnetic waves:

$$\underline{Z}_W = \sqrt{\frac{j\omega\underline{\mu}}{\sigma + j\omega\underline{\varepsilon}}} \quad (2.13)$$

with:

ω : Angular frequency of the shaft vibration

$\underline{\mu}$: complex permeability

σ : electrical conductance

$\underline{\varepsilon}$: complex permittivity

This consideration appears at first very detailed and not relevant for the direct further considerations. Accordingly, the execution is not pursued further, but should establish the necessary connections between the effects of the wavelength and the penetration of matter for the later argumentation.

Figure 2.9 shows the functional principle of micro-computed tomography (MCT). By rotating the object to be examined, many two-dimensional projection images are created on the detector, which are combined into a three-dimensional overall image with the aid

2. Theoretical Background

of a computer-aided reconstruction. By varying the position of the test object, the resolution of the measurement can be varied within limits. (Radon, 1917; Hounsfield, 1975)

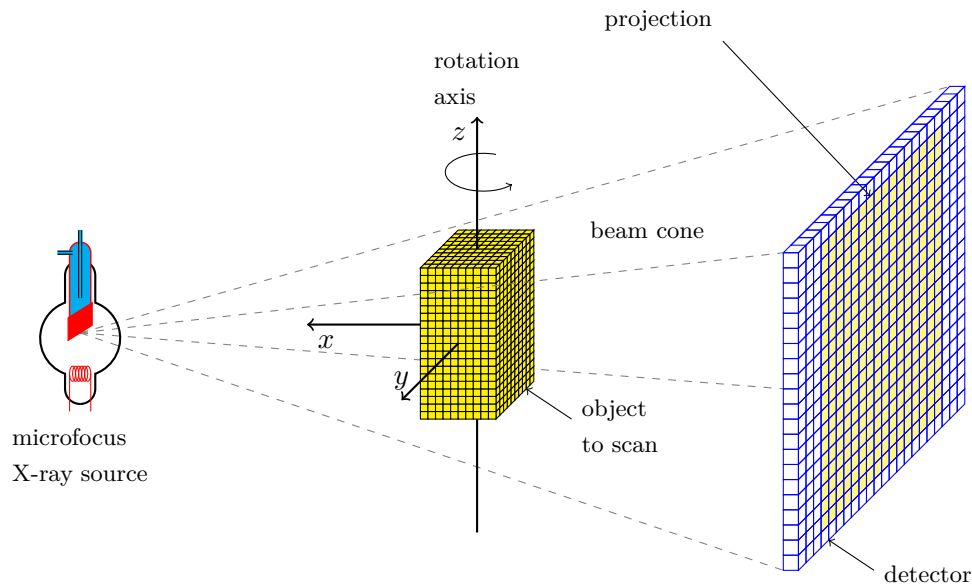

Figure 2.9.: Functional principle of micro-computer tomography: An irradiated object is rotated in front of the sensor surface. The resulting individual images can thus be combined to form a volume image.

2.2. Theory of computation

The core of this work is the design of a model in order to describe test situations and furthermore predict the needs and effort for these tests. This aims for an automated software solution, raising the question about computability and description of a situation in a mathematical form. Theoretical computer science provides precise definitions and methods about this questions. In the following, there will be a short overview about computability, the Turing machine and it's purpose, automats and languages.

2.2.1. Models, Computability and Turing machine

A model, usually means an abstract description or remake of a real object or situation. The abstract description of this object or situation can be the description of a start condition and the behavior. This sounds similar to an equation of a set of variables and is in fact known as the intuitive computability (Schöning, 2009). The Problem is now to know, if this function, respectively, this algorithm is computable with a machine. Even if it can't be proofed, the generally accepted Church's Thesis gives a way to determine if a function is computable (Schöning, 2009; Gurari, 1989; Smith, 1996):

2. Theoretical Background

Church's Thesis: A function is computable (respectively, partially computable) if and only if it is computable (respectively, partially computable) by a deterministic Turing Machine (Turing, 1936).

The Turing Machine is a very powerful tool in theoretical computer science. Each Turing transducer M can be viewed as an abstract computing machine that consists of a finite-state control, an input tape, a read-only input head, m auxiliary work tapes for some $m \geq 0$, a read-write auxiliary work-tape head for each auxiliary work tape, an output tape, and a write-only output head (Turing, 1936; Gurari, 1989). Even that it can't be build it leads the way to real computing machines. As an infinite tape can't be build in reality, no infinite problems can be computed. If a finite tape is used, it is possible to solve finite problems that fit on this tape. In a typical (real) computer, this tape is called memory (RAM). A problem solved by a Turing Machine, can be solved by a computer if there is enough memory or the problem is of manageable complexity relative to the computer performance.

For the following thesis this means, that the *Generic Model* has to be described in a way that can be interpreted by a Turing Machine. The next two paragraphs will show a way to do so.

2.2.2. Formal Languages

Leading the way to computability, there must be a way to formulate the question to the sought result. In case of a mathematical problem, an equation does this. The mathematical rules tell how to solve the equation. Similar to this well known example, a suitable language must be used to work with the *Generic Model*. Languages can be sorted into different classes which different characteristics. Each class of this Chomsky Hierarchy is included in the next higher class (Fig. 2.10) (Chomsky, 1956; Schöning, 2009). Regular languages are mathematical like languages and represent the most inner class (type 3), in contrast to the spoken language, which is even outside type 0 as depicted in Fig. 2.10. The latter is important because it still leaves the possibility to link a type 3 description with a spoken description, meaning that a formal language can be translated into a human comprehensible form, as a type 3 language is included in all other language types. Likewise, a non-formal representation of a test situation can be broken down into a formal description. In 4.2 a formal language for the *Generic Model* will be developed.

If Σ is an alphabet (finite set) with elements called *symbols* or *letters*, than a formal language can be any subset Σ^* of an alphabet Σ . To handle this kind of objects, *grammar* and *automates* are used. (Schöning, 2009)

Example based on Schöning (2009):

2. Theoretical Background

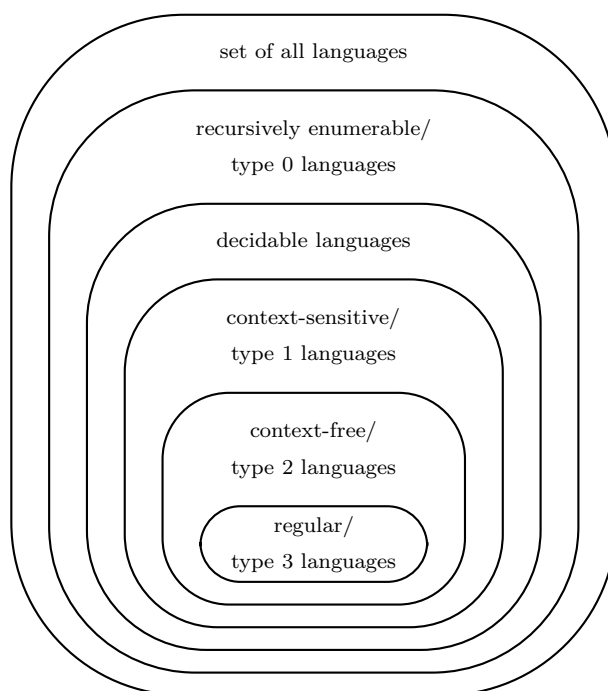

Figure 2.10.: Chomsky Hierarchy, showing different classes of languages (Chomsky, 1956; Schönig, 2009). From the outside to the center, the languages change incrementally from spoken language to mathematical like languages.

2. Theoretical Background

$\langle \textit{sentence} \rangle \rightarrow \langle \textit{subject} \rangle \langle \textit{predicate} \rangle \langle \textit{object} \rangle$
 $\langle \textit{subject} \rangle \rightarrow \langle \textit{article} \rangle \langle \textit{attribute} \rangle \langle \textit{noun} \rangle$
 $\langle \textit{article} \rangle \rightarrow \textit{the}$
 $\langle \textit{attribute} \rangle \rightarrow \textit{big}$
 $\langle \textit{attribute} \rangle \rightarrow \textit{fast}$
 $\langle \textit{attribute} \rangle \rightarrow \textit{small}$
 $\langle \textit{noun} \rangle \rightarrow \textit{dog}$
 $\langle \textit{noun} \rangle \rightarrow \textit{cat}$
 $\langle \textit{predicate} \rangle \rightarrow \textit{chases}$
 $\langle \textit{object} \rangle \rightarrow \langle \textit{article} \rangle \langle \textit{attribute} \rangle \langle \textit{noun} \rangle$

This grammar rules could produce the sentence: “The small dog chases the big cat.”

The later work will introduce a grammar to generate a language, able to describe a test situation. The next paragraph will show a way to “understand” this kind of language by a machine.

2.2.3. Languages, automates and computation time

The following paragraph will connect the language definition with the Turing Machine to enable the argumentation of how the *Generic Model* is computable.

In paragraph 2.2.1 the Turing Machine was introduced to determine the computability of a problem. Paragraph 2.2.2 than added a classification for languages to describe a problem. As type 3 languages, the so-called regular languages (compare fig. 2.10) have the most restrictions, this type will be used to demonstrate how the interpretation of a language can be done by a machine. A system, which has the ability to accept these language class, can be a nondeterministic automat (NFA) or a deterministic finite automat (DFA).

We can use the following definition of a DFA:

$$M = (Z, \Sigma, \delta, z_0, E) \quad (2.14)$$

Z : set of states
 Σ : input alphabet
 δ : transitional function
 z_0 : initial state
 E : set of final states

As these kind of machines *accept* type 3 languages they can be seen as counterpart to a type 3 grammar. This means in regard of the grammar example in 2.2.2 for an DFA:

2. Theoretical Background

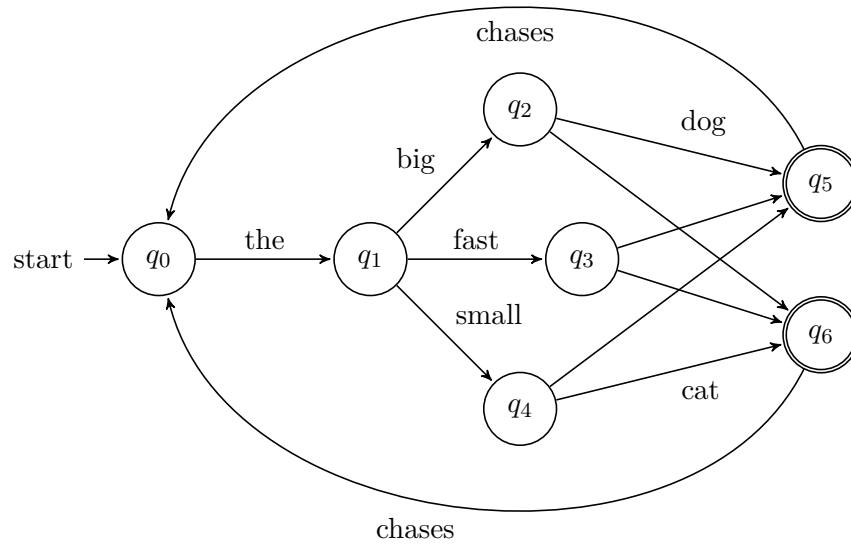

Figure 2.11.: Deterministic finite automat (DFA) able to accept the example grammar of paragraph 2.2.2. Walking through the graph, every sentence of this grammar can be created.

$$Z = \{q_0, q_1, q_2, q_3, q_4, q_5, q_6\} \quad (2.15)$$

$$E = \{q_5, q_6\}$$

$$\delta(q_0, \textit{the}) = q_1$$

$$\delta(q_1, \textit{big}) = q_2$$

$$\delta(q_1, \textit{fast}) = q_3$$

$$\delta(q_1, \textit{small}) = q_4$$

$$\delta(q_2, \textit{dog}) = q_5$$

$$\delta(q_2, \textit{cat}) = q_6$$

$$\delta(q_3, \textit{dog}) = q_5$$

$$\delta(q_3, \textit{cat}) = q_6$$

$$\delta(q_4, \textit{dog}) = q_5$$

$$\delta(q_4, \textit{cat}) = q_6$$

$$\delta(q_5, \textit{chases}) = q_0$$

$$\delta(q_6, \textit{chases}) = q_0$$

Figure 2.11 is a graphical representation of the DFA. A sentence belongs to the example

2. Theoretical Background

grammar if the DFA accepts it. Using the sentence “The small dog chases the big cat”, the processing sequence would be: $\{q_0, q_1, q_4, q_5, q_0, q_1, q_2, q_6\}$.

Regular languages are very limited if it comes to more complex problems. For example it is impossible to have a construct like “do something while a condition is true” (Schöning, 2009). This limitation leads to the use of type 2, and in further steps to the use of type 0 languages. It can be shown that all problems described with a type 0 language can be solved with a Turing machine and are therefore computable (Schöning, 2009). Concerning this work, this means if a test situation could be described with a type 0 or higher level language, computability would be assured. However it is important to keep in mind, that type 2 or lower languages do not have linear time and space requirements and might exceed available computation power.

2.2.4. Model building

While the previous paragraphs focused on computability, this paragraph will review the modeling itself. VDI (2014) describes a model as “Simplified reproduction of a planned or existing system with its processes in a different conceptual or concrete system. Its differences from the real system in terms of its characteristics that are relevant to the investigation are within a given range of tolerance.” Different specialized fields have their own adaptations for building models (method of model building), however the core similarity is the representation of a real system by reduced complexity and known limitation compared to the real system (figure 2.12) (Vogel-Heuser, 2011). The representation can be a technical drawing, a mathematical function, a diagram, or similar. Table 2.2 gives an idea of these possible representations. As the purpose of a model is the prediction of a certain behavior of a real system, only relevant parameters should be considered to reduce complexity.

Knowledge and understanding of models can vary. Two kind of models exist: structural or behavior models. For a structural model, the inner components are modeled, which requires a very specific knowledge about the system. In contrast, the behavior model gives an output prognosis based on a given input, which requires a lot of statistical data about the system but not the understanding of the system. Hybrid forms of both model types do exist as well. (Imboden, 2003)

The *Generic Model*, as described in later chapters, is a structural model which is based on sub models that can be behavior models themselves. This is based on the fact, that the performance of a NDT method is often a statistical information. For example is the capability of a method to detect an anomaly known as probability of detection (POD). This reflects the situation of not being able to guarantee an absolute determination. The *Generic Model* itself connects these and other information in a structural way to make a prediction about a complete test scenario or test situation.

2.3. Data storage and data access

The collection and organization of data can be seen as the beginning of model building and simulation (Imboden, 2003). Therefore, this paragraph deals with the technical

2. Theoretical Background

classification	formal foundation			behavioral description				time representation			structure			representation		
	formal	semi formal	informal	deterministic	non deterministic	static	dynamic	result driven discrete	time discrete	time continuous	hierarchy	composition/decomposition	structural alteration	textual	mathematical-symbolic	graphical
description form																
sequential function chart		x		x			x	x			x	x				x
algebraic model	x			x	x	x	x	x	x			x			x	
instruction list		x		x		x	x	x			x	x		x		
automats	x			x	x		x	x	x	x	x	x		x	x	x
function block language		x		x		x	x	x	x		x	x				x
function blocks according IEC/PAS 61 499		x		x		x	x	x			x	x				x
ladder diagram		x		x		x	x	x			x					x
Message Sequence Charts		x		x	x		x									x
Petri nets	x			x	x		x	x	x	x	x					x
Procedural Function Charts		x		x			x	x			x	x	x			x
program flow chart	x			x		x	x									x
Specification and Description Language	x			x	x		x	x	x		x	x				x
structured text		x		x		x	x	x			x			x		
VHSIC Hardware Description Language	x			x	x	x	x	x	x	x	x	x		x		x

Table 2.2.: Classification of possible methods to describe a model. According to Vogel-Heuser (2011) based on VDI (2005).

2. Theoretical Background

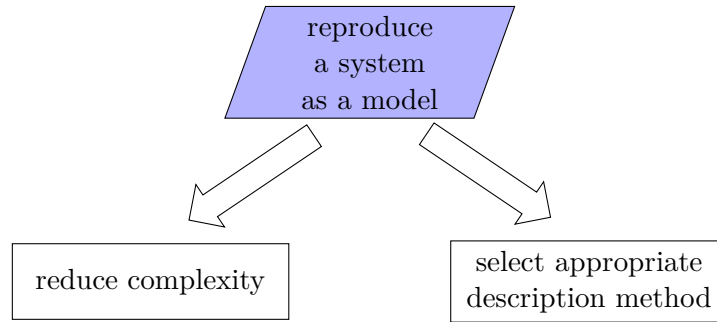

Figure 2.12.: Strategies to reproduce a system as a model. Based on Vogel-Heuser (2011).

question of information storage and access. As a first step, this can be seen similar to a library. The most important question is therefore, how to find the relevant information, e.g., all books about topic XY with less than 200 pages. Codd (1970) introduced a relational model to store information and a query language to access it. This structured query language (SQL) gained popularity when the American National Standards Institute (ANSI) adopted the first SQL standard in 1986. Continued work on relational databases led to improvements in SQL, making it one of the most popular existing database languages (Encyclopædia-Britannica, 2009). In the relational model, a database contains a set of tables. A table is made up of rows and columns. Each table has a name, which is unique within the database. Each column has a name and a data type. Each row constitutes one record in the table. A table may contain zero or more rows. A row is subdivided into fields, one per column. Tables may be used to model real-world objects and relationships. A database typically contains several tables. Each table in a database usually has one or more relationships to other tables in the database. (Donahoo & Speegle, 2010) Figure 2.13 shows a simple example of a school. In the upper part, a pupil is described with a name and an address. The entity pupil also contains a class name. This states the relation to a class and means that one pupil can be in one class. As many pupils can have the same class as an entry, a class can contain many pupils. This is also called a 1 to n relationship. The class itself has just the class name as an attribute. In the other direction, a pupil can listen to several subjects. However, a subject can be attended by more than one person. This many person to many subjects relationship is called a n to m relationship. In order to store this in tables, a connection table has to be defined which stores the corresponding subject with the related pupil. The same applies for subject and room but also for subject and teacher. This example is based on Codd (1970); Donahoo & Speegle (2010). In order to access information, a query might have to join several tables. Combining “subject” (table 2.3) and “pupil” (table 2.4) via the relations table (table 2.5) will result in a table with many lines (table 2.6) and show who is attending to which class. Selecting the appropriate lines allow to get the desired information. For example to find out who is listening to the physics class, only rows with “Physics” in the first column have to be selected. The answer would be “Slartibartfast”, “Ford Prefect” and “Marvin”.

This can be expanded over the complete relationship model. For example to get all

2. Theoretical Background

pupils, who get taught by teacher X, one has first to combine the tables “teacher” and “subject” via “teacher_teaches_subject”. Further more, table “pupil” has to be joined via “pupil_has_subject”. This gives a big table with all teachers, their subjects and the according pupils. Every Line of this table with teacher X has also a name of a pupil.

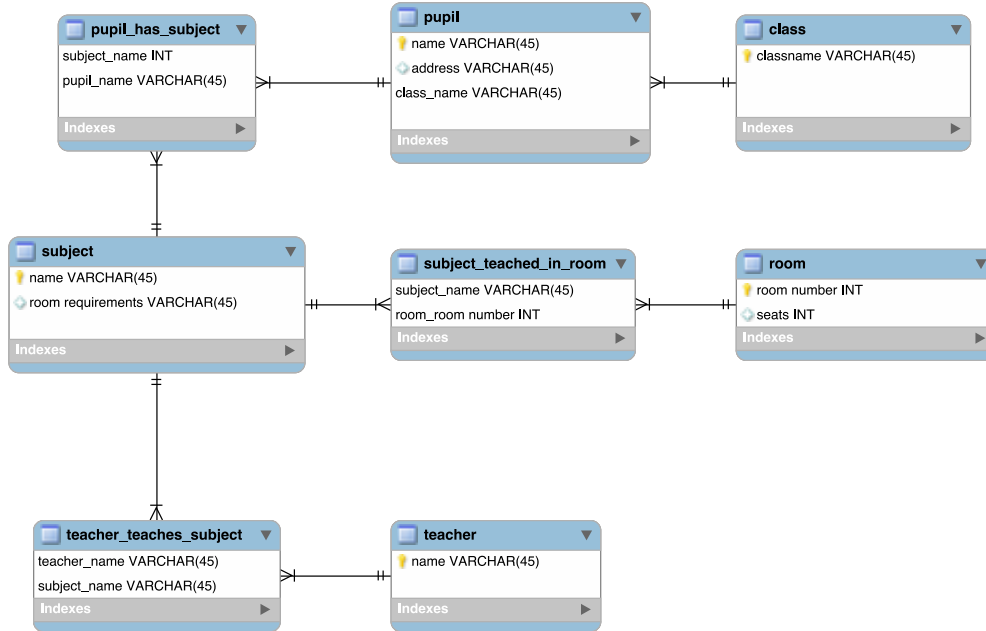

Figure 2.13.: Simple example of a table schema. It shows how pupils are connected with a class and which subjects they attend. Subjects are linked with teachers and rooms. It would be possible to find out, which pupils are taught in a certain room or which schoolmaster teaches which pupil. The following tables will list example values.

2.4. Procedure models and processes in product development and production

In the field of production and product development, methods are a common tool to support engineers and workers (Lindemann, 2009; Ehrlenspiel et al., 2005). These tools are focusing on production constraints, optimization of costs and development time but less on quality insurance and examination. The latter is, if mentioned at all, referred to as necessity but not as possibility for optimization (Ehrlenspiel et al., 2005; Engeln, 2006; Ehrlenspiel, 2007; Eversheim & Schuh, 2005; Kain, 2014). However, the aim to improve part quality and reduce cost are similar and therefore some basic ideas are similar. Engeln (2006) sees the motivation for product development in the need to be competitive. This is often expressed as a focus on cost reduction (Ehrlenspiel, 2007; Ehrlenspiel et al., 2005; Lindemann, 2009).

2. Theoretical Background

<i>name</i>	<i>room_requirements</i>
Math	none
Physics	Physics Lab
Biology	Bio Lab
Chemistry	Chemistry Lab

Table 2.3.: Example entries for entity subject.

<i>name</i>	<i>address</i>	<i>class_name</i>
Slartibartfast	Magrathean	3B
Arthur Dent	Earth	2C
Ford Prefect	Betelgeuse	4B
Marvin	Llankru	13Z
Zaphod Beeblebrox	Betelgeuse	1A

Table 2.4.: Example entries for entity pupils.

<i>pupil_name</i>	<i>subject_name</i>
Slartibartfast	Math
Slartibartfast	Physics
Slartibartfast	Biology
Arthur Dent	Chemistry
Ford Prefect	Math
Ford Prefect	Physics
Marvin	Biology
Marvin	Chemistry
Marvin	Math
Marvin	Physics
Zaphod Beeblebrox	Biology
Zaphod Beeblebrox	Chemistry

Table 2.5.: Relationship table of entities pupils and subject.

The approach to optimize the development process typically starts with the definition of product requirements (Engeln, 2006; Ehrlenspiel, 2007; VDI, 1993) and then uses different methods to come to a solution for the development of a product (Lindemann, 2009; Engeln, 2006; Ehrlenspiel, 2007). Ehrlenspiel (2007) and Eversheim & Schuh (2005) also focus on the human being within this processes and how an efficient communication between people is possible. Furthermore, a knowledge base is a common subject among these publications. Summarized, this leads to five major subjects:

1. definition of requirements.
2. methods to handle these requirements and control a development or production process.
3. existence of people in this environment and consideration of their needs.

2. Theoretical Background

<i>subject.name</i>	<i>subject.room_requirements</i>	<i>pupil.name</i>	<i>pupil.address</i>	<i>pupil.class_name</i>
Math	none	Slartibartfast	Magrathean	3B
Physics	Lab	Slartibartfast	Magrathean	3B
Biology	Bio Lab	Slartibartfast	Magrathean	3B
Chemistry	Chemistry Lab	Arthur Dent	Earth	2C
Math	none	Ford Prefect	Betelgeuse	4B
Physics	Lab	Ford Prefect	Betelgeuse	4B
Biology	Bio Lab	Marvin	Llankru	13Z
Chemistry	Chemistry Lab	Marvin	Llankru	13Z
Math	none	Marvin	Llankru	13Z
Physics	Lab	Marvin	Llankru	13Z
Biology	Bio Lab	Zaphod Beeblebrox	Betelgeuse	1A
Chemistry	Chemistry Lab	Zaphod Beeblebrox	Betelgeuse	1A

Table 2.6.: Combined tables subject and pupil. The tables are joined via the relationship table 2.5.

2. *Theoretical Background*

4. communication is an essential part of an efficient processes.
5. a knowledge base works as a basis for the next iteration of a product and is inevitable to be competitive.

Even if this work focuses on the development of a *Generic Model*, these ideas shall be considered in designing it and set parameters for its justification.

3. Situation analysis of Non Destructive Testing

As mentioned in chapter 1, the actual work starts with the situation analysis of NDT. The basic idea behind it is the understanding of the field of priorities in an industrial development and production process. The aim of this work is improving the impact of NDT by communicating its needs to different places in the process chain. Therefore, an elementary understanding of this process chain is necessary.

First a short definition of the purpose of NDT will give a possibility to locate testing itself within this process as well as understand what expectations other faculties might have. Subsequently, the influence and input parameters on NDT will be considered. Finally, a run-through of the complete process with one example part will be performed. This chapter also shows the approach in creating the *Generic Model* as well as the steps leading to it.

3.1. Purpose and context of NDT

In order to review Non Destructive Testing (NDT) in an organizational and process context, the purpose and benefit of the performed tests have to be taken into account. The production cycle of a part starts with the definition of requirements to fulfill its intended function. Based on these requirements, a product is designed by taking all the different constraints such as material, production options or costs into account. After the production of a product, compliance with these requirements must be verified (Fig. 1.1) (VDI, 1993). One of the important methods for this quality assurance is non-destructive testing. In case of the limits being exceeded, there are different options. The part can just be rejected or a further analysis can prove, that the part is usable after all. Therefore the "Effect of Defect" has to be evaluated to understand the implication of an imperfection in the part (Oster, 2012). From this process constellation, where NDT results function as acceptance criteria for production parts, arises a great potential for conflicts in a development and production environment. It is mandatory to consider this human factor and combine it with the discussion of technical issues.

As mentioned before, a part with unfavorable geometry can cause increased test effort and therefore higher costs and longer test time. Clear definitions of factors such as anomalies, effects, geometry or signals that are applicable for design and stress division as well as for production and testing faculties can be a basis for a common language. This common ground might lead to an optimized design based on optimal use of NDT to lower cost and weight.

3. Situation analysis of Non Destructive Testing

On a concrete perspective, NDT is embedded in a very specific set of requirements and expectations. This will be discussed in the next paragraphs and lays one of foundation stones for the *Generic Model*.

3.1.1. Possibilities and expectations for non-destructive testing

NDT methods offer a great variety of possibilities to determine inner features of a part. This is based on the different physical principals addressed in chapter 2.1. In some way, energy is transmitted to the part and by observing the responding signal, a conclusion about its inner structure can be drawn. In quality assurance, typically a threshold of the signal change is used to determine the fulfillment of requirements. If the possibilities and limits of the method are known, a reliable and qualifiable inspection of parts on quality aspects is possible. In an industrial context, this is part of NDT development, which involves qualification of measurements, perform examination, refine techniques and test procedures or even develop completely new methods and techniques to move the boundaries of detection. The next step is to visualize the measurement results. This could mean correlation of a SI Unit with a color code or to combine several single measuring points to one image.

As an inspection depends on several different aspects, it is not always obvious when or how it can be performed. To non-experts, this is like a black box without clear description. Apparently, this may lead to wrong and often exaggerated expectations. In practice it is often the case, that NDT should have solved a problem in a miraculous way. This situation partly contributed to the motivation for this research and shall be one key point of the *Generic Model*.

To sum up these thoughts, relevant factors for the the *Generic Model* are the inspection performance, the type of result and, in a general perspective, the communication with people not being NDT experts. Table 3.1 summarizes these properties for this, and the next paragraphs.

3.1.2. Requirements of non-destructive testing

In the paragraph above, physical principles are mentioned as basis of NDT methods. This implies physical constraints that allow an inspection to be performed. For example, an electromagnetic wave must be able to penetrate a component in order to perform an X-ray inspection. Also, requirements regarding the surface of a component are very often relevant. Furthermore, different NDT methods have different requirements regarding accessibility. Beside these specific component or object oriented requirements, there are meta requirements such as NDT inspection personnel, infrastructure or safety. If NDT inspection in principal is possible, these superordinated demands can counteract an inspection in an industrial use-case. Related to these requirements are disturbances having negative influence on a measurement, e.g., a heat source in a thermography inspection or a noise during an acoustic emission experiment. The knowledge about these requirements and disturbances is valuable information of NDT experts and can decide if a inspection process runs well or fails. Obviously, the physical requirements are

3. Situation analysis of Non Destructive Testing

fixed but the meta requirements are bound to the specific environment.

3.1.3. Special needs of serial production regarding NDT

As a third aspect, NDT in a serial production environment shall be considered. This is often handled as subordinate problem, as the main focus is on the isolated performance of the NDT method, disregarding its implementation in serial production. However, regarding NDT as part of the production process, it is a sufficient condition that has to be satisfied. Grosse (2016) describes a holistic concept for an efficient selection of NDT and SHM techniques in the context of quality control (figure 3.1).

Meta requirements, as mentioned in paragraph 3.1.2, are typical constraints in serial production. An inspection that is possible in an laboratory might not be an option in serial production due to high costs or long duration. Automation is mainly a direct consequence of the effort to reduce inspection time and cost and therefore is a relevant interest of mass production. Manual work and small product quantities are classical cost driver in aeronautic production and it can be a huge effort to enable an automated inspection. For example was it a challenges to enable automated inspection for the Airbus A350 passenger door, due to its complexity. This shows the importance of a better connection between part design and NDT requirements, especially for high rate inspection processes. It also explains the growing popularity of robot-assisted testing.

3.1.4. Inspection data analysis and storage

Depending on the purpose of an inspection, further data analysis and storage might be relevant. One option is a simple documentation with the location of an anomaly in the inspected part, the other could be the storage of this “meta-data” data during the inspection. This is typically defined by an inspection instruction and of minor interest for the next steps of this work. However in order to improve the knowledge *where* in a component anomalies are located and if there is an accumulation at certain geometry features, it might be relevant. It is therefore assumed that all data is available if necessary. Nowadays, this is discussed with buzzwords like “big data” or “industry 4.0”. Machine learning with deep neural nets to analyze the data are also a big subject for further discussion.

3.2. Input and boundary conditions on NDT inspections

To transfer the paragraphs of chapter 3.1 to a more specific example, figure 3.2 lists input from different departments and interest groups. They are condensed into four streams: the interests of the company on a business perspective and the customers interest on good products. Also the requirements of development (stress/design) and NDT are relevant. With this four main input streams, this seems rather simple. Considering however, that only for NDT seven, respectively six (communication is an aspect with no input here), categories with twenty-four items ($4 * 2 * 6 * 6 * 2 * 4 = 2304$ combinations) were listed above. This leads to a huge variety of different test situations. Assuming similar

3. Situation analysis of Non Destructive Testing

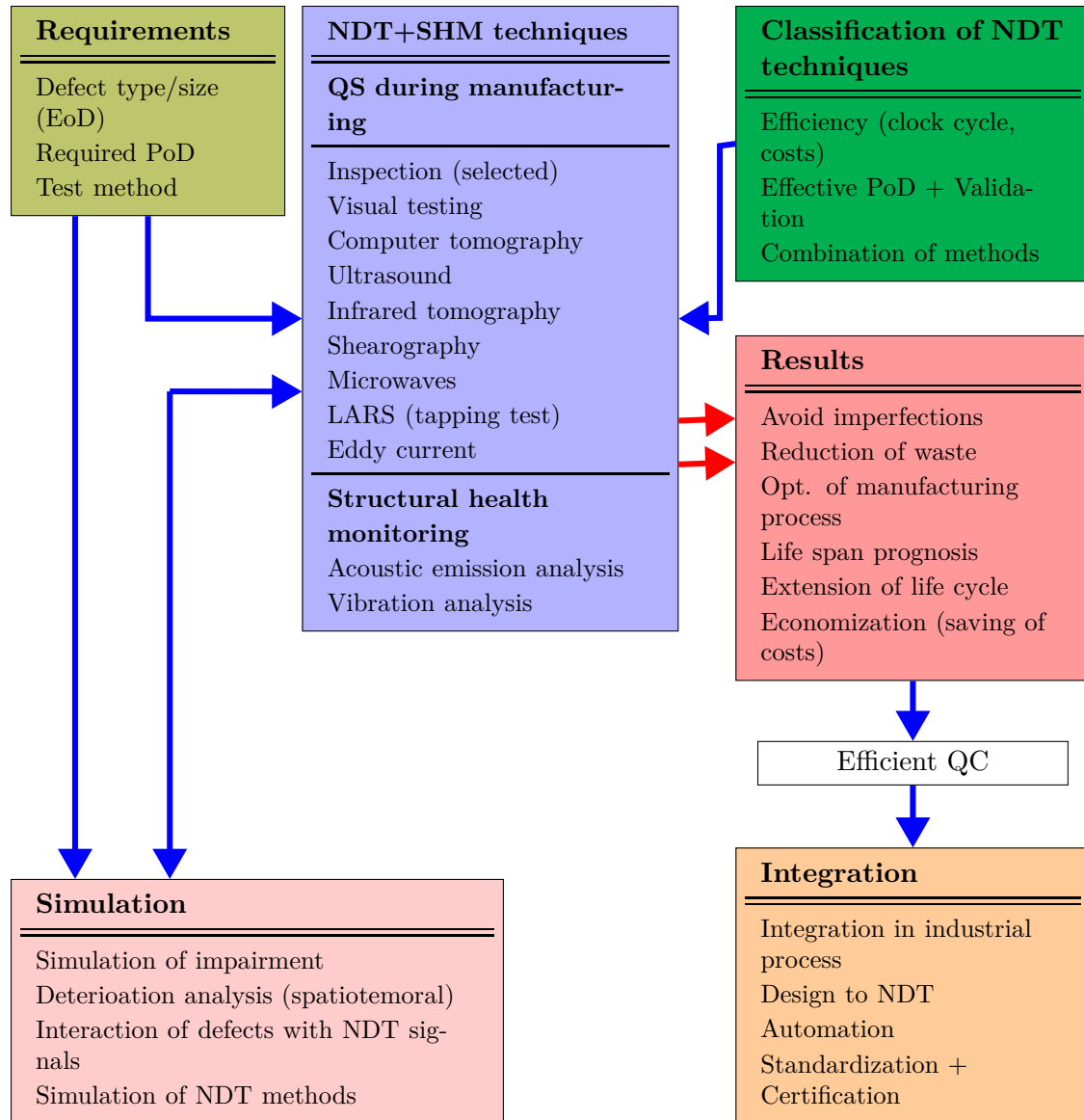

Figure 3.1.: Holistic concept for an efficient selection of NDT and SHM techniques in the context of quality control. Based on (Grosse, 2016).

3. Situation analysis of Non Destructive Testing

category	subject	example
possibilities and expectations	inspection performance	test sensitivity, accuracy, reproducibility, range (penetration depth) (4)
	result	type of result, quantitative vs. qualitative (2)
	communication with non NDT experts	
requirements	object requirements	surface, material, coupling, auxiliary material, contamination, accessibility (6)
	meta requirements	personal, safety, permissions (e.g. radiation), calibration/referencing, infrastructure, energy demand (6)
	disturbances	type, magnitude (2)
serial production	effort	direct costs, inspection speed, automatability, setup time (4)

Table 3.1.: Relevant aspects of NDT methods divided in categories *possibilities and expectations*, *requirements* and *serial production*.

complexity in the three other branches and only 5 possibilities for each item, this would be around $1,7 * 10^{30}$ possibilities in total for different input parameters $((2304 * 5^6)^4)$. It is save to say, that every test situation is different and a generic approach must be used to create a way of describing this test situation. Of course, this various input parameters are not chosen randomly. If an input parameter is no longer just one of the options but has a value for a certain reason it is called boundary conditions or constraint. The sum of these conditions/ *constraints* are the context of a test situation. A decision against an X-Ray inspection could have the reason that there is no possibility to guarantee radiation protection. In Principle, it would be possible but doesn't meet a specific requirement. This builds up to a chain of constraints which in the end leads to the specific *test situation*. In order to connect the theoretical discussion to an example from a real production environment, the next paragraph will consider the production process of a helicopter tail boom.

3.3. NDT in the overall process

To broaden the understanding of how a NDT test situation is created by the various inputs and therefore understand what the needs of different people and faculties in the process chain are, a closer look to a real process chain is done. This is realized by analyzing the production process of a helicopters tail boom, which is the back part of

3. Situation analysis of Non Destructive Testing

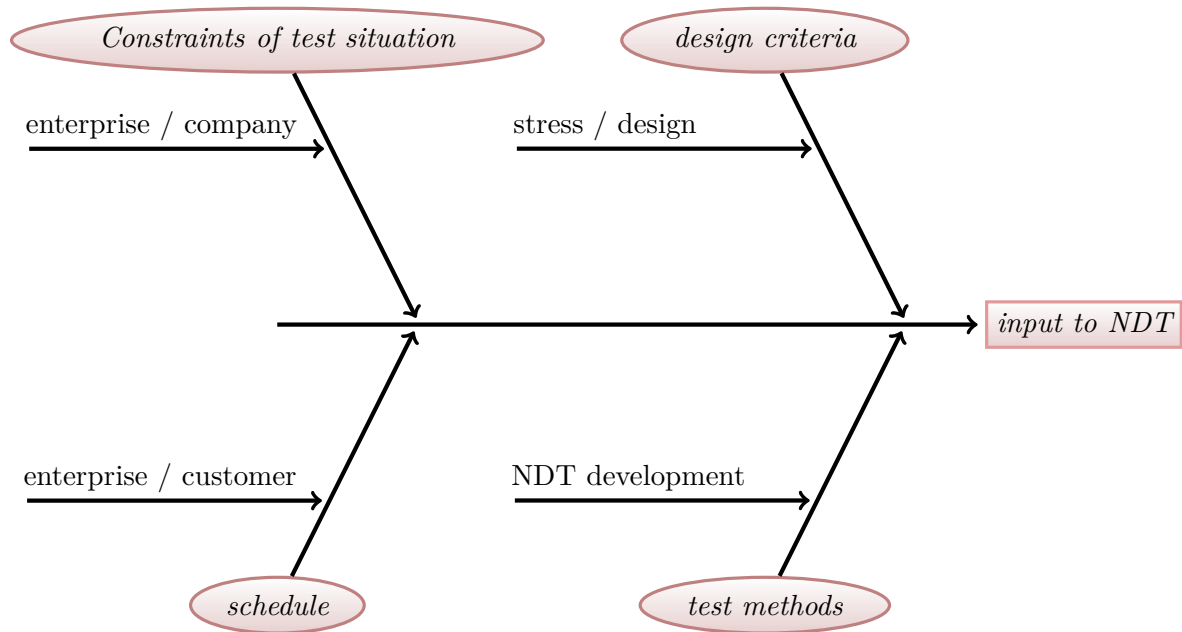

Figure 3.2.: Different input or boundary conditions which lead to a specific test situation.

the helicopter with the moment balancing tail rotor, the so-called Fenestron[®] (figure 3.3). The process was analyzed by starting at the last step of the production in the final assembly line (FAL) and traced every step back until the roll of CRFP fabrics. Additional interviews with construction and design engineers gave a further look into the beginning not only of the production, but also of the design process. With this understanding, possible interfaces between NDT and the others faculties are analyzed.

3.3.1. Analysis of overall development and production process of a helicopter tail boom

The swim lane diagram 3.4 shows the most significant steps of the tail boom production process. It is separated into the lanes “Design & Stress”, “Production” and “Quality Management”. While the first lane describes the design and development phase with a focus on fulfilling the load and stress requirements, the second line shows the different steps of the production and connects them to the quality management. The third line represents a collection of quality insurance steps during production.

Even if this analysis helped to understand the needs of different faculties, it revealed no new information about the situations in which NDT is used. However, it confirmed the late involvement of NDT in the design process and the need to do otherwise. During the interviews (see A.1) this was clearly requested, with a focus on direct communication and simple “do and don’t” advises. This supports the theses of embracing the *Generic Model* as a toolset but also as a basis for a common communication language.

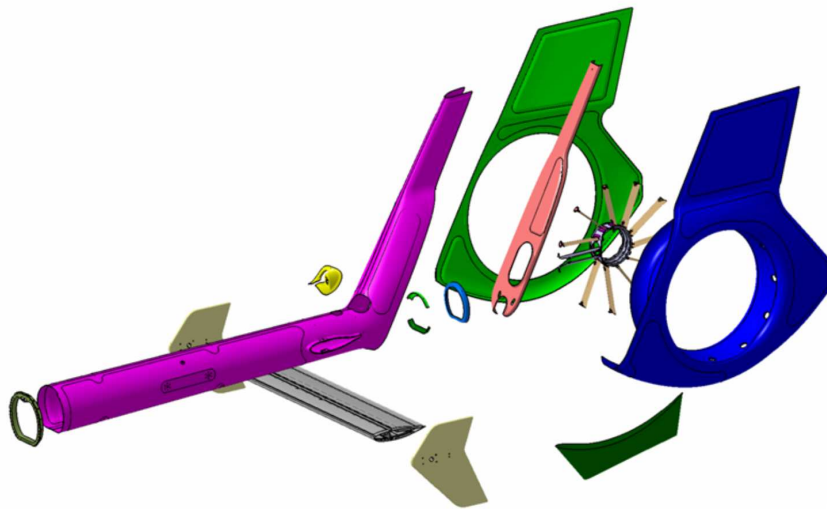

Figure 3.3.: CAD model of a helicopter tail boom (Airbus Helicopters Deutschland GmbH, 2015).

3.3.2. Interfaces between testing and other faculties in the overall process

While looking for possibilities to improve the overall process by means of NDT, the interfaces between NDT and other faculties of the process were considered. This is mainly based on the process analysis of subchapter 3.3.1 and the mentioned interviews. For each faculty, the input, output and interface to NDT is noted. A short discussion reveals possible improvements.

Design and construction process

These departments are obviously of great interest for later review, as they mark the beginning of the process and changes there have the highest impact (Ehrlenspiel et al., 2005). In regards of influencing the process from a NDT perspective, working with design and construction departments is a promising approach.

- Input:
Input to design and construction are *requirements* considering load factors and size constraints. Given a complete product (like a helicopter or car) a mission profile is drawn: How many passengers, how fast, how far and similar aspects. This draft gives design and construction teams a first working basis. Depending on calculations, further requirements are defined and passed to sub-components.
- Output:
Output is the *final design* of the product or component. The designer will supervise the creation at least until the first prototype.
- Interface to NDT:

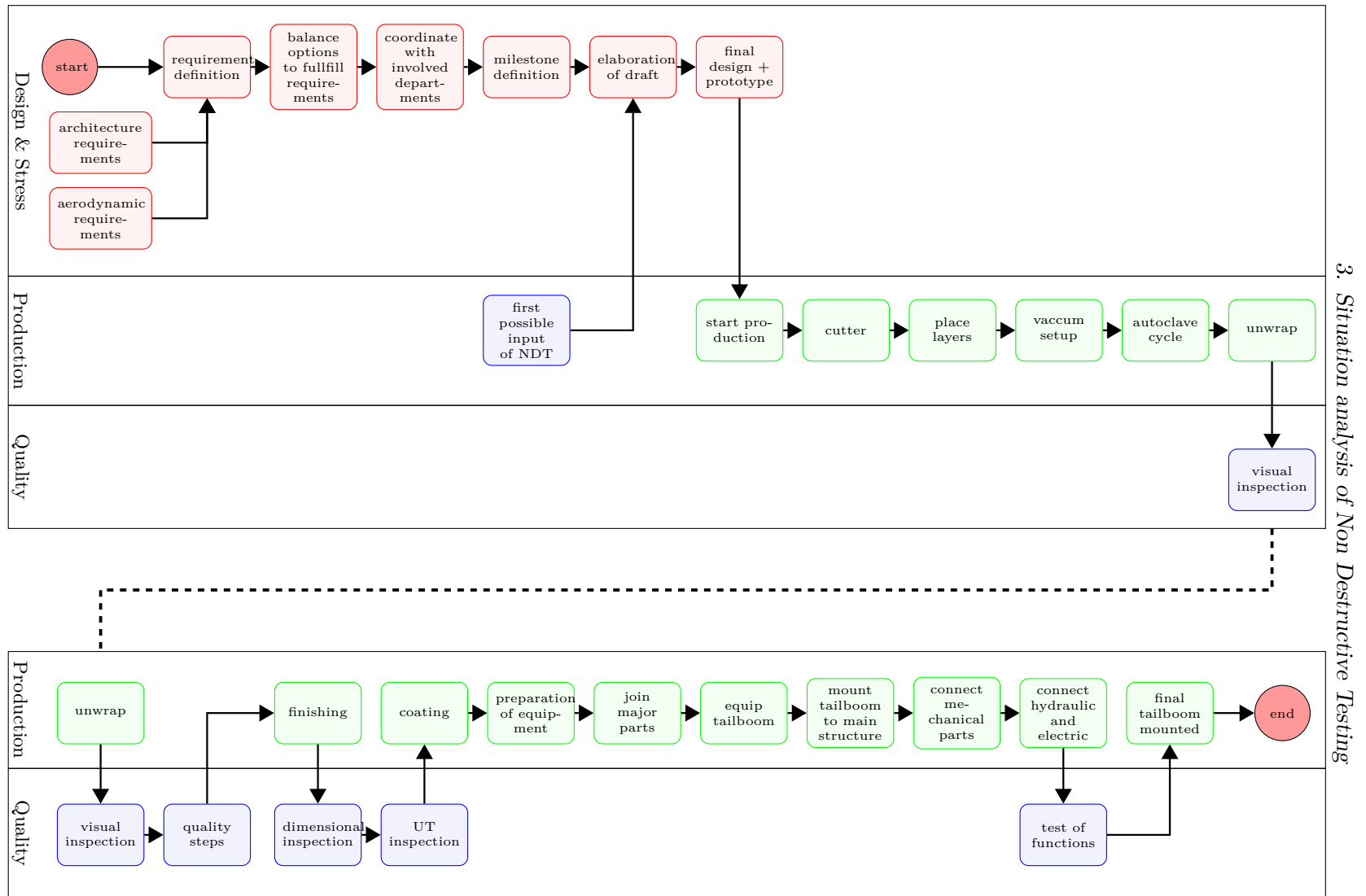

Figure 3.4.: Development and production process of a helicopters tail boom. Starting with the requirement definition and finishing with the final assembly. The swim lane diagram shows the involvement of design and stress departments, the production process and quality ensurance steps.

3. Situation analysis of Non Destructive Testing

So far, no explicit interface to NDT is defined. The consideration of NDT in design and construction is based on experience and personal contacts. One of the mentioned suggestions to create an interface to NDT is a milestone gate in order to elaborate a draft and include NDT aspects. This is marked in figure 3.4 as “first possible input of NDT”. Of course any design change should, before finalized, again consult with NDT.

As mentioned earlier in chapter 1, the consideration of NDT might help to create better parts and enables easier inspection in the production (Schmiedel & Holzheimer, 2016). Regarding the importance of this process step and the lack of explicit implementation of NDT, a clearly visible improvement can be expected by helping design and construction with easy guidelines about NDT needs and possibilities to improve testability during and after production. A software tool might help to get the right balance between support and restricting the work of these teams.

Stress, structural and dynamical calculation process

This process step evaluates a design in terms of static and dynamic load, also taking into account various environmental influences. Due to this, it works in close loop with design and construction.

- Input:

For load calculations, information on *load* and *corresponding design* are the obvious input. This can be done in form of *design schematics*, *drawings*, CAD models (including finite elements (FE) analysis) or *written descriptions*.

- Output:

The according output are the *design schematics* and *drawings* with the *corresponding calculations*.

- Interface to NDT:

There is no direct interface to NDT but only the connection via design and construction departments.

It might be possible to consider this part of the process as sub-process of design and construction. In fact, the work of stress departments are similar to NDT departments: both analyze a part with respect to certain aspects. As the design team has the sovereignty of a part from an organizational perspective, they should be the focal point for communication. However, on a technical note, it would be beneficial to have one common model of a part to do structural and NDT analysis and connect this to a “digital twin” of the part.

3. Situation analysis of Non Destructive Testing

Production process

Moving into the production phase, influence on the part (from a design perspective) is more difficult. The task of NDT must be a support, as efficient as possible, in order to have a smooth production process with no rejects due to an uncertainty in inspection. Improving the production by supporting manufacturing enhancements with NDT could also be useful.

- Input:

The output of the design phase at the same time is the input to production in form of *design schematics* and *drawings*.

- Output:

Beside the actual component, a lot of documentation, production schematics and production drawings are created in this process steps. Depending on the industry, part classification and safety requirements, these documents have to be stored over the complete lifetime of a product.

- Interface to NDT:

The interface to NDT is typically represented by the quality insurance. This is defined and organized by the quality insurance departments. In order to monitor the various manufacturing steps, components are given to the quality insurance department for inspection. In these specific process, this is done for visual inspection after the autoclave, dimensional inspections and ultrasonic inspection on every single part. After production, a final function test finishes the process.

Similar to the stress and structural calculation process, the production process has its connection to NDT via quality insurance. This is important for an independent inspection but it reduces interaction as well. Using NDT knowledge and inspection output as statistical information could be a future enhancement for improving manufacturing steps. If an anomaly is often detected in the same area of a part, this should be addressed in order to improve part quality.

Quality insurance process

Non destructive testing is one of the important tools for quality insurance. Beside it, the monitoring of the processes, documentation and other inspection methods are part of quality insurance.

- Input:

The input is a component (e.g. tail boom) and a corresponding criteria definition for anomalies or imperfections (given by the design department). Based on this definition, the inspection is set and performed. A simplified test criteria could be “inspect for delamination bigger than 40 mm^2 in this part”. In reality though, these definitions are quite detailed and well documented.

3. Situation analysis of Non Destructive Testing

- Output:

After inspection, the output is the according test documentation and the part itself. If not all inspection criteria are met, the part is blocked and stored in a confinement area until further steps are approved. This approval is upon the designer of the part.

As quality insurance is the native location of NDT, the according departments are responsible for distributing any NDT improvements to the other faculties. The actual quality insurance departments are mainly focused on production, so an additional NDT development department should be responsible for improving NDT abilities and also communicate and establish new NDT possibilities and processes.

Maintenance process

The maintenance process is similar to the above discussed quality process, but with huge restrictions caused by limited accessibility. It is much more difficult to inspect a part after it is installed in the main product than the inspection of a separate part. However, the principal process structure and interfaces are the same.

To summarize the consideration above there are two major points. First, NDT restrictions and needs must be taken into account as early as possible in order to be most efficient but there are also possibilities to improve limited aspects later in the process. However, the foundation is laid early in the process as constraints to NDT inspection are mostly dependent on shape and material of a component. These geometric parameters dominate all of the later steps and should be the focus of further steps. Of course, the influence of other properties like surface, type of possible defects, inspection parameters et cetera, should not be ignored. Second, there are a lot of people with different background in different departments involved. They need to communicate and have a common understanding of the actual situation.

3.3.3. Expectation and situation of NDT in the overall process

To summarize this chapter, two topics have to be reviewed. The expectation of different faculties and the situation as it is. This defines the gap, the *Generic Model* has to bridge.

The major groups involved in the process chain are design and construction, production, quality insurance and NDT itself. Most interest for early consideration of NDT is expressed by the designers, as they need insurance about part quality. Quality was discussed in chapter 1 as the fulfillment of requirements. However there is no active exchange between NDT departments and the design teams. Certain possibilities of NDT (mostly UT) are taken for granted, based on the experience of earlier designs. During production, NDT is not really present as the product is transferred to the quality management for examination. For quality management it is important to have a cost efficient solution to perform inspections but no steps are taken so far to influence the design process.

3. *Situation analysis of Non Destructive Testing*

In summary, NDT is hardly present and only seen as necessity during the design process and as a tool in quality management. In the design process, the need for NDT is known, but often ignored or considered too late. The *Generic Model* could help to solve this problem as the inclusion of NDT has clear benefits (paragraph 3.1, Schmiedel & Holzheimer (2016)). It must fulfill two major tasks: ease the communication of limits and possibilities of NDT and analyze these constraints in an easy way on a part design. The next chapters will build up the model from a theoretical perspective, show how the discussed needs and expectations are considered and how this could lead to a possible software tool to be used on a daily basis in the design process.

4. The Generic Model - Automated evaluation of test situations

The previous chapters have highlighted the position of NDT in an industrial environment. Different perspectives of different faculties have been considered and their interactions with NDT were shown. Together with the theoretical background of chapter 2, this lays the foundation to create the *Generic Model* as presented below. The following chapter not only show the final model but also the steps leading to it.

4.1. Requirements for the Generic Model

Before working on the actual model, a short summary of the requirements regarding the *Generic Model* shall give a clear objective.

As mentioned before, arises a great potential for conflicts in a development and production environment from NDT as a *quality ensurance tool*, where NDT results act as acceptance criteria. It is mandatory to consider this human factor and combine it with the discussion of technical issues. This supports the intention of employing the *Generic Model* as a *tool for communication* between faculties. Along with a better communication the intended higher efficiency and therefore *cost saving* effects can be expected. To allow communication, the *Generic Model* has to handle relevant information about inspection performance, the type of a result, possible geometries and accuracy. In addition, the *needs of serial production* have to be addressed and an according way of inspection data analysis and storage has to be enabled.

As the *Generic Model* has to deal with different *test situations*, *input* and *boundary conditions of NDT*, inspections have to be the basis of the model. Table 4.1 collects the relevant requirement and can be used as reference during this chapter.

4.2. A formal language to describe test situations

Reviewing the requirement summary of paragraph 4.1 shows a significant need for communicating and describing different aspects regarding testing and test situations. To allow an unambiguous way of communication, the first step will be to create a formal definition of what a test situation is. Subsequently, a description of a formal language can be constructed, based on this definition.

For a flexible model it is important to figure out, which parts of the model have to be adaptive to the test situation and which ones are static. The model that illustrates these situations can be described as the relation of three entities to each other:

4. The Generic Model - Automated evaluation of test situations

no.	requirement
1	<i>quality ensurance tool</i>
2	<i>tool for communication</i>
3	<i>cost saving tool</i>
4	<i>consider needs of serial production</i>
5	<i>describe test situations</i>
6	<i>describe input of NDT</i>
7	<i>describe boundary conditions of NDT</i>

Table 4.1.: Requirements a *Generic Model* needs to meet in order to describe NDT test situations.

1. Used test method
2. Analyzed part or rather geometry
3. Indication or (detected) anomaly

Different test situations are distinguished from each other by the values allocated to the three entities, but are still covered by the relation of this basic triple. Therefore, this set of variables will act as the basis for the *Generic Model*. To enable the standardization process, the model has to address not only the needs of faculties within the field of NDT but also the ones detached from NDT. The needs of the different faculties basically differ in their focus on the three entities method, geometry and anomaly, where an anomaly can be an imperfection or a defect. Design and stress departments need to know if a certain anomaly or number of anomalies per volume might be present in a given geometry, whereas for NDT, the possible employed method is of importance. The discussed preconditions led to an entity relationship (ER) model with these three major focal points. ER models, as explained in paragraph 2.3, are designed to structure information in order to store it in database systems. The function is based on the mathematical set theory and stores data of each entity in a two-dimensional tables, where the columns represent the attributes (properties) and each row stands for one specific entity. In addition, this structure allows storing information about relationships by referring to another entity. Figure 4.1 and tables 4.2, 4.3 and 4.4 give a brief and simplified example.

For the following examples, all anomalies are of type I, II or III. The geometry is limited to A, B and C. Test methods do not necessarily match exactly actual existing methods. What is the ideal way to inspect parts of geometry A or B based on the given information in this example? Geometry A and B only contain anomalies of type I or II (union of row 1 and 2 on column 3). The set of test methods that can detect anomalies I or II are method 1 and method 2 (intersection of “I, II” with column 4 of table 4.4 “test methods”). Sorted by effort, the return value is „method 1“. The query how to find foreign substances, combined with not using X-Ray techniques, will lead to method 3. Geometries A, B and C will be the response to the question, which shapes can be

4. The Generic Model - Automated evaluation of test situations

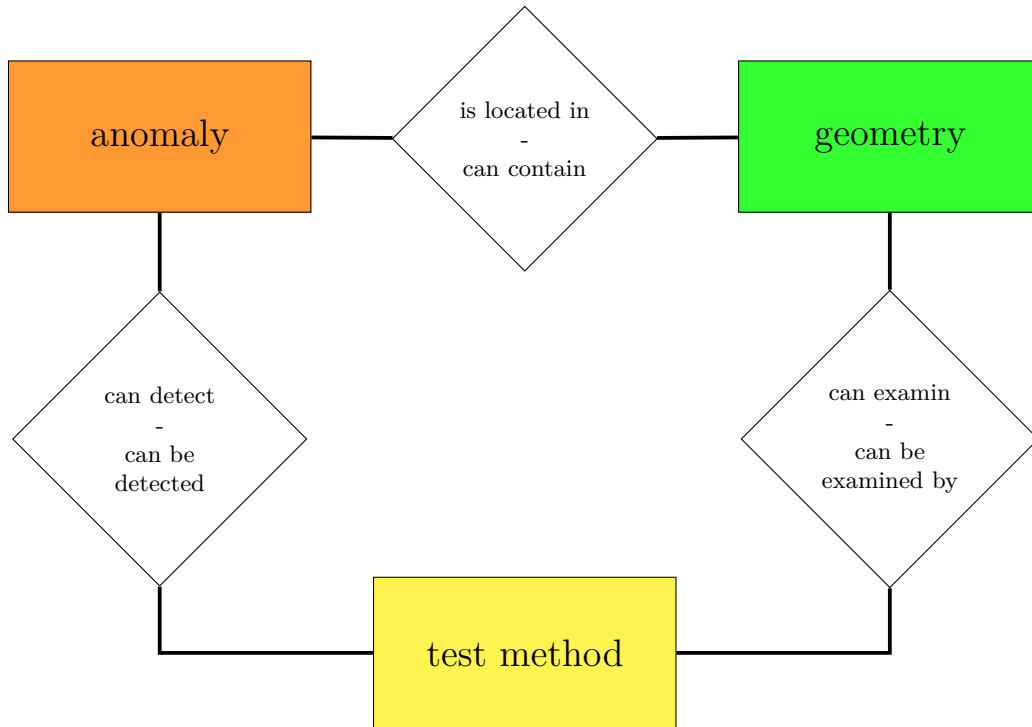

Figure 4.1.: The core of the *Generic Model* is the static part with the entities geometry, anomaly and test method. The connection of these entities build up the functional part of the model.

tested with method 2. For employment of this model in real application, it needs to be more detailed, a point that will be subject of further discussion. Also the possibility to use the combination of method 1 and 3 to replace method 2 might be of interest.

With this idea of a *test situation* the basic playground for the *Generic Model* is set. The following steps will build on the three entities *geometry*, *anomaly* and *test method*. Each entity will be reviewed and analyzed in order to understand and describe its behavior and the interaction with the other entities.

This basic structure also provides an idea how the *Generic Model* can work as tool for communication, but also to predict a precise behavior about the testability of an element (figure 4.2). Sections 4.3.1, 4.4 and 4.5 show in detail how this can be done.

Anomaly	Name	Type
	Anomaly I	Delamination
	Anomaly II	Porosity
	Anomaly III	Foreign Substance

Table 4.2.: Example list for entity "Anomaly" with different attributes.

4. The Generic Model - Automated evaluation of test situations

Geometry	Name	Shape	Can contain Anomaly of Type
	Geometry A	Flat	I, II
	Geometry B	Curved	II
	Geometry C	Connection	III

Table 4.3.: Example list for entity "Geometry" with different attributes.

Test Methods	Name	Based on Technology	Applicable to Geometry	Can detect Anomaly Type	Test Effort
	Method 1	Ultrasonic	A, B	I, II	minor
	Method 2	X-Ray	A, B, C	I, II, III	major
	Method 3	Thermography	A	II, III	average

Table 4.4.: Example list for entity "Test Method" with different attributes.

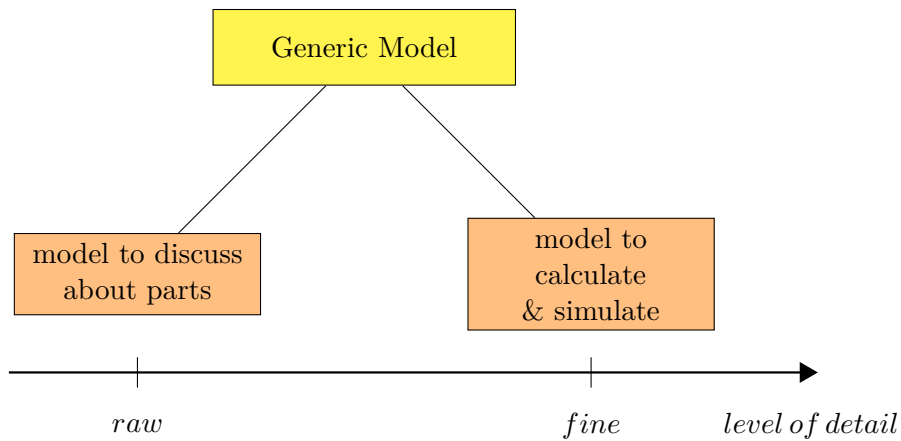

Figure 4.2.: It is mandatory to have two views on the *Generic Model*: one to describe and talk about parts and one to calculate and simulate.

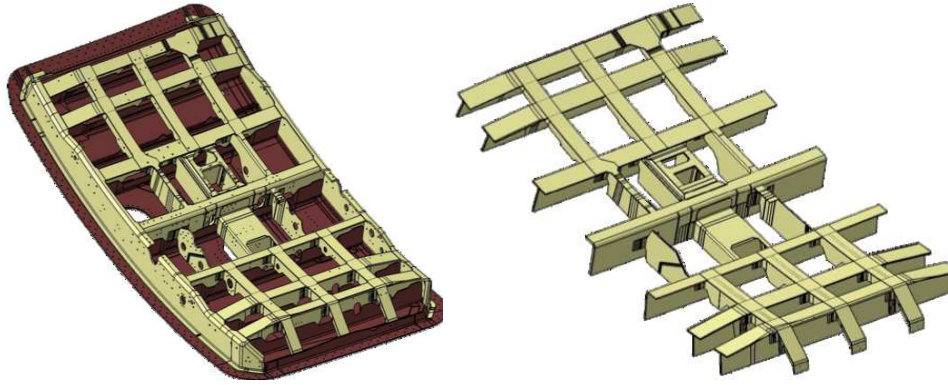

Figure 4.3.: A complex part completely made of CFRP with many challenges for a NDT inspection.

4.2.1. Formal description of geometry

The work and research on the formal description of a geometry is a central element of this thesis. In this paragraph, not only the result will be described and explained but also the way to the final description. Especially the change from the original node based approach of generic elements to a *Generic Model* of (infinitesimal) small elements represents the development of an engineer driven perspective to a more abstract model.

The part which originally triggered the thoughts for this research had a similar structure as the example cut out (figure 4.4) of the example part shown in figure 4.3. This part is dominated by steps, wedges, ramps, corner blends and is hard to examine by typical NDT methods. In order to find the best options for inspection of the part, it seemed suitable to take a systematical approach of analyzing repeating structure elements instead of testing the entire part at once. It is a classical way of breaking down the complexity of a part. Figure 4.5 shows the original steps which were taken in red to green and the advancement to finite elements in blue.

This led to a first list of possible elements to build up any arbitrary part by combining them in different variations (table 4.5). Bearing the part from figure 4.3 in mind, the origin and development of this first steps is easy comprehensible. Even if it is not the final form of the model, this step was very helpful and therefore necessary to take the next steps and to communicate the idea of a *Generic Model*. Especially for the latter reason, dealing with the described generic elements should be considered regarding communication with other faculties. This would harmonize with the requirements of two views on the *Generic Model* made in chapter 4.2 and figure 4.2.

4.2.1.1. Description of an element with connected nodes

While the previous paragraph has shown the first steps to break down a complex geometry, this section presents how, based on the defined structure, the description of a single element was developed.

In order to take up the idea of the basic elements from table 4.5 again, the structural

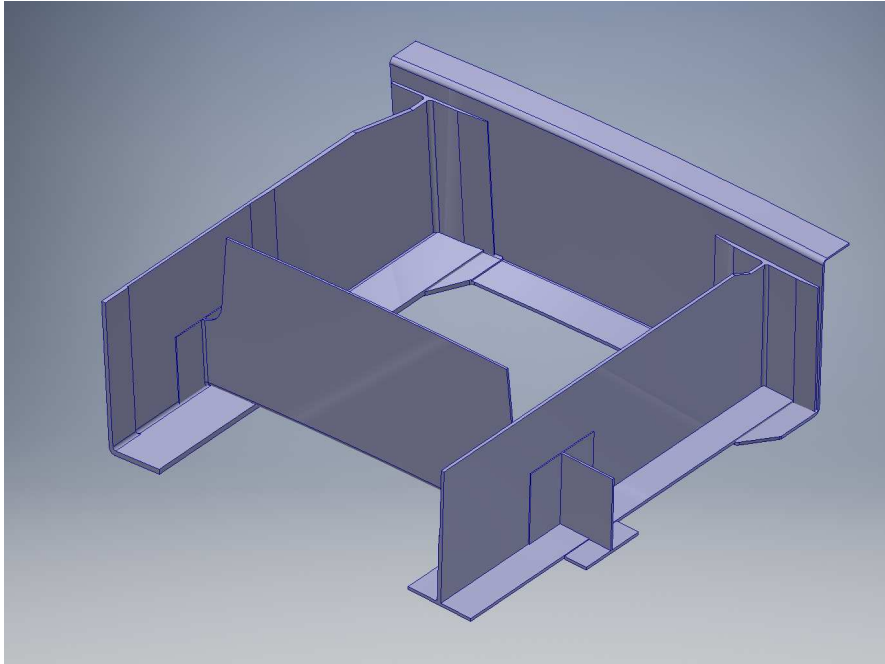

Figure 4.4.: Complex example part with many obstacles for NDT inspection: Corners, edges, wedges, steps and curvature make this part difficult to inspect.

name	description
beam	connects two nodes in a straight line
curve	connects two nodes as curve with radius R
L-Profile	two beams combined to form a L shape
T-joint	connects 3 nodes with a center nodes in straight lines
double T-joint	connects 4 nodes with a center nodes in straight lines
corner blend	connects 3 node points with one nodes point but not a center point
ramp	slow thickness change
step (thickness)	sudden thickness change

Table 4.5.: Basic elements to build up an arbitrary part by combining them in different variations. This is meant as an abstract geometry description without units but can be mapped on real dimensions.

4. The Generic Model - Automated evaluation of test situations

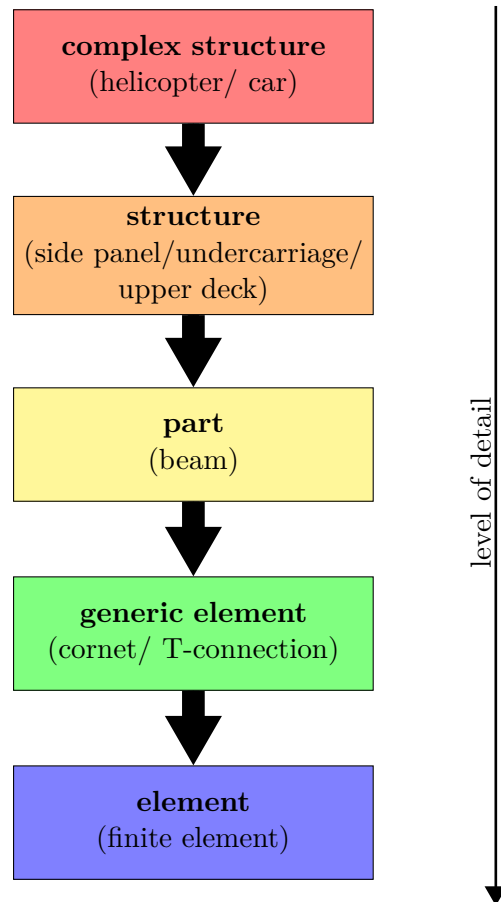

Figure 4.5.: Break down of a complex part into simple elements. The steps from *red* to *green* show the original idea which was extended during the research to include finite elements (*blue*).

4. The Generic Model - Automated evaluation of test situations

Action	formula	Comment
node n with number m	n_m	
direct length x to next node	Lx	filled with actual length
absolute angle (in coordinate system) of path	$\alpha = \text{angle}$	
optional parameters	-	not yet defined
radius y to next path, if it exists	Ry	
node with number	n_{m+1}	must allow to build up radius with predecessor path

Table 4.6.: Sequence of basic rules to describe a geometry with connected nodes.

description with connected nodes shall be described first. Figure 4.6 shows without units, the most relevant elements represented with connected nodes in two dimensions. The first example shows two nodes connected by a defined distance of 100. This is noted as node-distance 100-node or n-L100-n. An arc would be defined by an additional radius. To describe a L shapes profile three nodes are used in the second example. The distance to the first node is given, than the angle with appertaining radius and finally the distance to the second node. The nodes are numbered counter clockwise. The third example in figure 4.6 follows the same principle for a T-joint. Table 4.6 summarizes the sequence of rules to describe a geometry according to these examples.

With this first procedure to describe a geometry, the additional properties can be defined. In figure 4.7 an entity relationship model (ER model, chapter 2.3) of geometric elements is provided. After label and size description (“name”, “dimension”) all further information is connected to the node and the connecting line. Especially informations about layer structure and material. It is worth mentioning that these properties are mostly independent from the given ER model and will be used in a similar form in the later model.

4.2.1.2. Describing a geometry in three dimensional orientation and switch to finite elements

The example in figure 4.6 showed how to use nodes and lines to build up a two dimensional geometry. Expanding this approach to the third dimension leads to a model with edges and planes, where edges correspond to nodes and planes to lines. Again this leads to an extremely complex description, especially considering curved parts. In order to solve different obstacles in handling the connecting edges, several smaller supporting elements where needed. This led to the conclusion of describing the complete surface of a geometry by finitesimal elements of triangle shape. Of course, this is no new approach (e.g. Ožbolt et al. (2011)) but a direct result of finding a possible way of modeling the geometry. As a consequence, two views on the model (figure 4.2) are necessary, but at the same time an elegant and proven solution of geometry description can be used: The

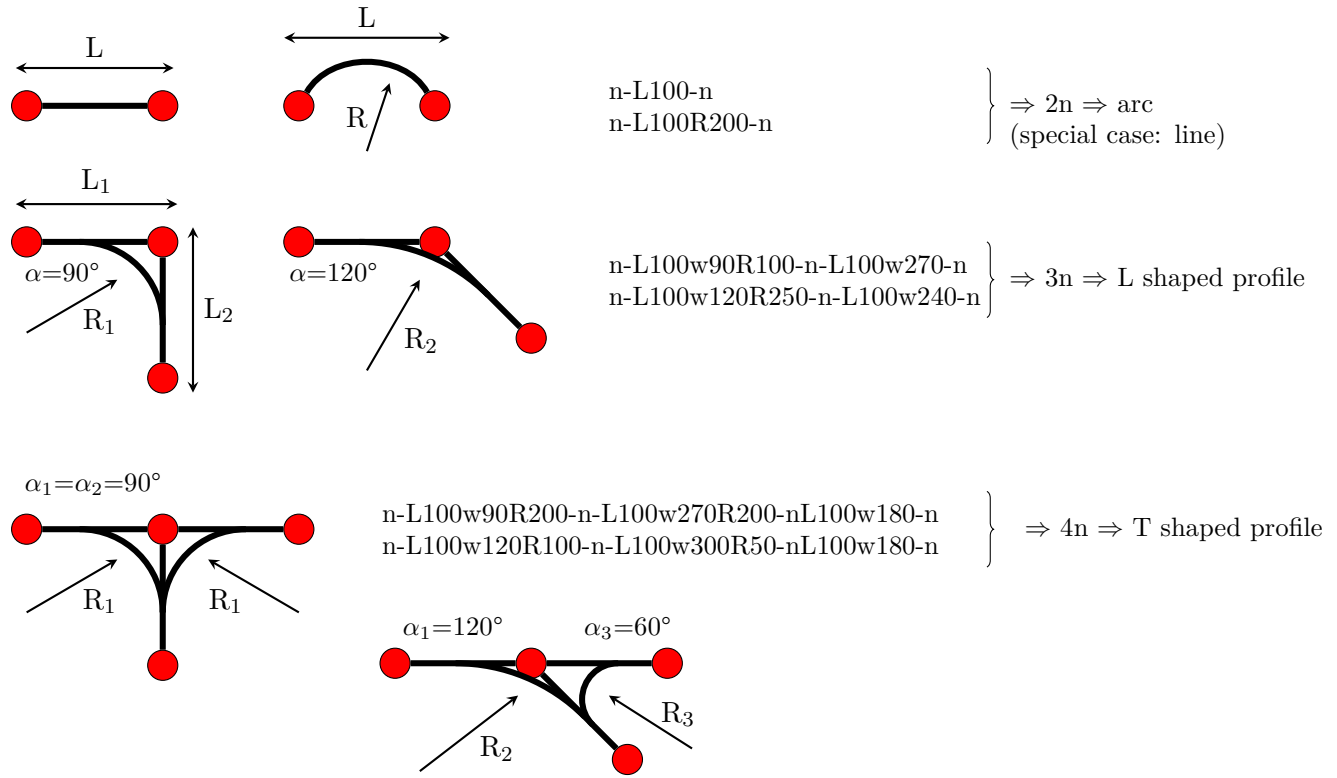

52

Figure 4.6.: Generic description of a structural element in 2 dimensions. With given rules, the nodes are connected by a defined distance, arc and angle. The dimension length “L” should not be confused with “L shaped” geometrical form.

4. The Generic Model - Automated evaluation of test situations

descriptive way described above, which is the approved way for humans to communicate and on the other hand an efficient and often used surface description that will be explained next.

In order to describe an element surface, a mesh of triangles has to be created. Fortunately, this is a well solved problem and to improve compatibility for later steps, the *Standard Tessellation Language* (STL) (Weiler, 1985) will be used to describe parts within the *Generic Model*. A STL file uses the unit normal and vertices of the triangles in a three-dimensional Cartesian coordinate system to describe a surface. A plain surface can be generated by two triangles, but an edge needs many vertices. As shown in the two dimensional figure 4.8, the tessellation is always an approximation. The more vertices the better the later calculation but the higher the computational effort needed.

Regarding the consideration of NDT, for every finite element (triangle) a computation regarding inspectability has to be performed. Therefore, every vertex needs its own set of properties. This can be a given value such as the material or a prior computed number like thickness or curvature. The next paragraphs will demonstrate this approach in more detail and provide examples like the curvature calculation (4.5.1) as well.

As already mentioned, two different views on the *Generic Model* (figure 4.2) must be considered. The V-Model of the *Generic Model* connects the computational surface description with human communication about parts and elements. To link finite elements and single generic elements, a feature change must be detected. For example, a corner element has actually a curvature greater than 0 while a plane has a curvature of 0. The change from >0 to 0 marks the change from corner to plane surface. Using the center of feature changes, one can build up a structure of generic elements where the midway of two centers are the overlapping areas. A combination of different properties (like curvature in the example) has to be defined for the considered generic elements like L-, T- or corner-element.

4.2.1.3. Description parameters for finite geometry elements

The discussed idea to describe a part geometry with a surface built up by a mesh triangles requires a parameter set for the triangles (table 4.7). To describe a part properly, this set has to be filled with information for each triangle.

The most relevant information is the location of the triangle. This is realized by coordinates in a cartesian coordinate system. According to the STL standard, x, y, z coordinates have to be stored for each corner of the triangle. In addition, the normal vector distinguishes between inside and outside. The curvature and thickness are derived information but should be calculated just once and then stored for performance reasons. In contrast, the material must be provided as an external value. Also, a layer setup of different materials cannot be calculated. Directly related to the STL-representation is the surface of the part at a certain point.

4. The Generic Model - Automated evaluation of test situations

parameter	stored value
coordinates	$[x_1, y_1, z_1], [x_2, y_2, z_2], [x_3, y_3, z_3]$
curvature	$[\kappa = \frac{1}{R}]$
depth/thickness	[l]
material	[m]
layer setup	[s]
surface condition	[c]

Table 4.7.: Parameter set to define the geometry of a part. The coordinates shape the basic triangles. Curvature and thickness give further geometric information supported by material parameters to analyze inspection possibilities.

4.2.2. Formal description of an anomaly

Following the considerations for the geometry of a part, the same has to be done for the anomaly. Based on the results of the geometry description, a similar specification of an anomaly is possible. The anomaly is obviously of central importance for the whole NDT process. Therefore, additional parameters, along with the geometric information, are of interest. The focus will be on production based anomalies and not on defects in service.

Aspects to consider are based on the question “why test for an anomaly?”. More detailed, this is linked with the person who is concerned with an anomaly and which aspect of the anomaly is of interest. In the context of this work, this problem is of interest to everyone who takes care of statical and dynamical part stability. Depending on the relevant properties of a product, this can be different. For the consideration of part stability, typically these are the static and dynamic departments. They need to calculate the strength of a part, considering the presence of an anomaly. To do so, the type, location, size and number of the anomaly are the most important parameters. In the field of aviation, considerations are mainly based on safety aspects. For each anomaly, it must be decided whether or not it has an impact (*effect*) on aviation safety. Conversely, limit values are defined for each relevant component. If an anomaly exceeds these limits, a *defect* is said to exist. This is described as *Effect of Defect* (EoD) and triggers all actions by setting limits for the part acceptance.

Anomalies always emerge within a process (e.g. impurity gets into raw material) but they exist in most cases in the actual product (figure 4.12). To eliminate anomalies in production, knowledge about their origin is crucial. Geometric problems can be traced back in the process and, for example, lead to a change of pre-product geometry. Considering production parameters like temperature, pressure, melting time, it becomes more complex. Also, the discovery of a root cause (e.g. prior anomaly) is often not trivial. In this context, a *Big Data* approach might be useful. Even this work cannot go into detail, the idea is to provide the basics for a Big Data procedure by giving the description of parameters to collect. This *Origin of Defect* (OoD) has the focus on avoidance and prediction of a defect. Avoiding an anomaly by gaining knowledge about the critical process parameters or non beneficial part designs offers a huge advantage

4. The Generic Model - Automated evaluation of test situations

No.	description	time frame	example	process
1	impurity in raw material	production	contaminated resin	
2	contamination / process failure		silicone on carbon fabric	x
3	discontinuity in pre-product		missing layers	
4	contamination / process failure		forgotten protective film	x
5	anomaly in product		delamination	
6	damage in service	in service	tool drop, fatigue	x
7	damaged repaired product		impact damage, fatigue	

Table 4.8.: Possible origins of an anomaly during production and in service as shown in figure 4.12.

for production and cost savings. Linking process parameters with defects, might also work in the other direction, by monitoring the process. If a wrong parameter always leads to a specific anomaly, no further investigation or even production has to be done if this parameter is monitored. This extended or inline NDT offers the possibility for time reduction and better focus of NDT resources.

Summarized, requirements, geometric information, origin and effect have to be considered (figure 4.10 and 4.11).

Figure 4.12 and table 4.8 give possible origins of an anomaly during production or in service. This (extensible) list for the *Generic Model* should also store the moment of emergence and its cause (figure 4.13).

4.2.2.1. Description of the anomaly geometry

The geometric information of an anomaly can be described very similar to the geometry of the part itself. An anomaly can be seen as a geometry defined within a part that has an own parameter set (figures 4.14, 4.15). As shown in table 4.9 this is also done by a finite mesh description as shown below. As additional parameter an anomaly density is introduced in order to describe features such as porosity, not as single pores but as an area with pores. Also, the origin of an anomaly, as discussed above, is included.

4.2.2.2. Description of the anomaly effect

The *Effect of Defect* is an important topic, however with respect to the model it is a meta information and not directly stored with the anomaly information. It can be described as feature of an anomaly in general but also bound to a specific anomaly. Especially, if the origin of an anomaly and the effect have to be connected, it has to be done via an anomaly. In an industrial context, a critical effect sets a high priority to avoid this

4. The Generic Model - Automated evaluation of test situations

parameter	parameter subset	stored value	comment	Class
unique ID of anomaly		[ID]	also connects finite element to anomaly	basic
density		[d]	for anomaly types such as porosity	
type		[t]		type
	name			
	description			
	matter (phys.)			
	interface			
coordinates		$[x_1, y_1, z_1],$ $[x_2, y_2, z_2],$ $[x_3, y_3, z_3]$	relative depth to part geometry is derived	
curvature		$[\kappa = \frac{1}{R}]$		cause
origin		[o]		
	name			
	root cause			
	time of emergence			

Table 4.9.: Parameter set to define the geometry of an anomaly. This is similar to the geometry description of table 4.7 but is extended to include further parameters for anomaly description.

defect, and backtracking into production is needed (from effect to origin). Even this is not part of the present work, the frame allowing this possibility is given by the *Generic Model* and will be further discussed in chapter 6.

4.2.3. Formal description of the test methods

As shown in figure 4.1, the geometry, the anomaly and the test method have to be considered in order to describe a test situation. Test methods have two types of properties: One is two connect with the other entities (geometry, anomaly) and the other is used to compare different methods regarding their performance. This calls for a multitude of properties, as displayed in figure 4.16. As NDT test methods are well known and well described in the testing environment, a compatible nomenclature has to be found. It needs to be independent, as far as possible, from the properties but also allows to describe the required information.

4.2.3.1. Nomenclature to address a test method

The nomenclature for a test method has to fulfill two aspects: Be compatible to the rest of the *Generic Model* and support the people who want to use and talk about it. Considering the output of the *Generic Model*, the method description is used by writers and readers of test procedures, the latter often being the NDT inspector who acts on this procedure. Also if the test method is used as input parameter for the *Generic Model*, the starting point is a known test method. Based on discussions within the *MAI ZfP* project, the nomenclature should include the following information:

- distinct identification of the method
- classification (method/ technic)
- needed equipment for an examination (including auxiliary materials)
- performance and usability

To address the first two points, the method name and a distinct method class are used. A set of preparation parameters lists requirements for equipment but also safety and personal requirements. Object requirements and inspection performance describe the scope in which a method can be used. In summary, this leads to the nomenclature of table 4.10.

4. The Generic Model - Automated evaluation of test situations

parameter name	stored value	Class	Comments
method name	[ID]		basic parameters
method class	[class ID]		
surface requirement	$[o_s]$	object requirements $[o]$	interaction parameters
coupling	$[o_c]$		
additive substance	$[o_a]$		
possible material	$[o_m]$		
required space	$[o_b]$		
detectable anomalies	anomaly.[ID]	inspection performance $[p]$	scope parameters
sensitivity	$[p_{sm}]$		
resolution	$[p_r]$		
reproducibility	$[p_w]$		
range	$[p_{rm}]$		
personal requirements	$[e_p]$	preparation $[e]$	performance comparison
safety requirements	$[e_s]$		
approval requirements	$[e_a]$		
calibration/referencing	$[e_r]$		
infrastructure	$[e_i]$		
energy consumption	$[e_e]$	result $[r]$	
result representation	$[r_f]$		
quantitative/qualitative result	$[r_q]$	direct cost $[c]$	
direct cost	$[c_c]$		
inspection speed	$[c_s]$		
automation possibilities	$[c_a]$		
set-up time	$[c_t]$		
disturbance	$[s_d]$	disturbance $[s]$	
disturbance relevance	$[s_r]$		

Table 4.10.: Possible parameters for test methods, that can be formally described and analyzed by the *Generic Model*.

4.2.3.2. Performance comparison of test methods

The test method possesses two sets of characteristics which can be seen as necessary and sufficient conditions to find the best suited test method for an inspection: One set to calculate the interactions with part geometry and anomaly and a second set to enable a cost function in order to compare the method's performance relative to other methods or, alternatively, give further information about the method. That is, set one helps to calculate whether a test method can be used at all (e.g. accuracy is sufficient) and set two helps to find the best suitable method. This is basically done with a list of

4. The Generic Model - Automated evaluation of test situations

the different characteristics where every entry originates from one method. To generate this list, a suitable value for each parameter of a method has to be chosen, leading to an overall performance for the method (eq. 4.1). An example for one characteristic is the time an inspection takes. Depending on the needs, the characteristics have to be prioritized (e.g changing the loading k for the parameters “time” and “cost”) and an ordered list, based on overall performance, will be the result.

$$\text{overallPerformance} = \sum k_n * \text{normalized Performance}_n \quad (4.1)$$

k : balance factor

This comparison can be visualized as “rotating” NDT magic cube: Two axis locate the method according to interaction and scope parameters (table 4.10), where the third axis gives a comparison between methods and can be switched (like a magic/rubik cube, figure 4.17).

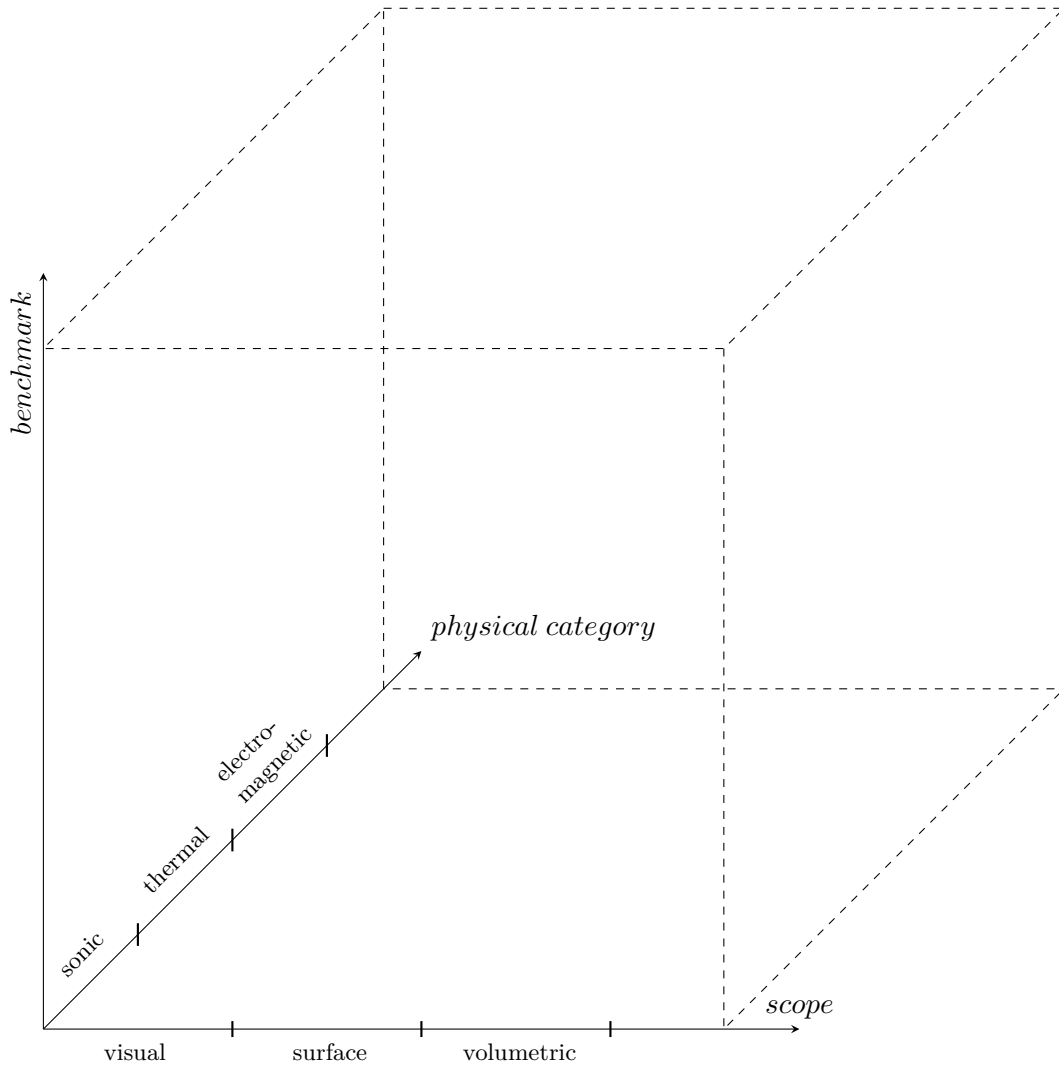

Figure 4.17.: NDT magic cube to benchmark test methods. Test methods can be allocated to a scope group and a physical category. By using a benchmark value for all methods, a comparison between the methods is possible. Switching this benchmark (like a magic/rubik cube) gives a complete picture of the performance.

4.2.4. A formal language to describe geometry, anomaly and test method

Chapter 2.2.2 introduced the principle of formal languages. This section demonstrates how the previous definition of parameters for geometry, anomaly and test method are put together to a formal language. A formal proof will show the language being a type 3 language and therefore its computability.

The basis of this language is the definition of the test situation. As already mentioned, a test situation consists of geometry, anomaly and test method, as shown in figure 4.18.

4. The Generic Model - Automated evaluation of test situations

state	transition state	equation	short notation
<test method>	definition of table 4.10	4.3	a
<capability>	can inspect	4.4	b
<capability>	can not inspect	4.5	c
<geometry>	definition of table 4.7	4.6	d
<detectability>	can detect	4.7	e
<detectability>	can not detect	4.8	f
<anomaly>	definition of table 4.9	4.9	g

Table 4.11.: Sorting the notation of the grammar in order to have an better overview in the definition of the language.

After starting with the definition, the next step is to transform it into a useful statement. The interest is to know whether a test method is capable of detecting a particular anomaly on a particular part. The corresponding grammar is build up in schema 4.2. The state of test method, anomaly and geometry are given in the sections above in tables 4.10, 4.9, 4.7 and therefore are not written down explicitly.

$$\langle \text{test situation} \rangle \rightarrow \langle \text{test method} \rangle \langle \text{capability} \rangle \quad (4.2)$$

$$\langle \text{geometry} \rangle \langle \text{detectability} \rangle \langle \text{anomaly} \rangle$$

$$\langle \text{test method} \rangle \rightarrow \text{definition of table 4.10} \quad (4.3)$$

$$\langle \text{capability} \rangle \rightarrow \text{can inspect} \quad (4.4)$$

$$\langle \text{capability} \rangle \rightarrow \text{cannot inspect} \quad (4.5)$$

$$\langle \text{geometry} \rangle \rightarrow \text{definition of table 4.7} \quad (4.6)$$

$$\langle \text{detectability} \rangle \rightarrow \text{can detect} \quad (4.7)$$

$$\langle \text{detectability} \rangle \rightarrow \text{cannot detect} \quad (4.8)$$

$$\langle \text{anomaly} \rangle \rightarrow \text{definition of table 4.9} \quad (4.9)$$

After defining a grammar, the formal language based on this grammar has to be defined. As only <capability> and <detectability> allow different options, this leads to the simple regular language as shown in equation 4.10. The notation uses the abbreviation of table 4.11.

$$\begin{aligned}
 \delta(z_0, a) &= z_1 & (4.10) \\
 \delta(z_1, b) &= z_2 \\
 \delta(z_1, c) &= z_3 \\
 \delta(z_2, d) &= z_4 \\
 \delta(z_3, d) &= z_4 \\
 \delta(z_4, e) &= z_5 \\
 \delta(z_4, f) &= z_6 \\
 \delta(z_5, g) &= z_7 \\
 \delta(z_6, g) &= z_7
 \end{aligned}$$

In order to proof, that this language is a type 3 language and therefore computable, the language has to be accepted by a finite state machine (FSM) or a deterministic finite machine (DFA) (Schöning, 2009) (compare chapter 2.2.3). This means, if a FSM that accepts or produces this language, can be drawn, the language is regular (type 3). The FSM sketched in figure 4.19 shows one possibility and ensures that the defined language can be used to describe and calculate a test situation as defined above.

4.3. Use of the formal language in the Generic Model

The *Generic Model* consists of two major elements: A static part that describes the test situation (fig 4.1) in order to provide a description basis for the functional part that shows the interaction of the static elements (fig 4.23). As discussed in Mosch et al. (2016), the three basic elements of the test situation are the geometry of a part, the anomaly and the test method. In an organizational context, they are represented by design (geometry), stress (anomaly) and NDT (test method) departments. In the model, each entity has further branches which allow a detailed description. The geometry, for example, includes curvature, thickness and material of a part. The test method holds information about constraints regarding the NDT inspection. For information about possible imperfections, the entity “anomaly” exists. The properties of these three entities are related, in order to interact within the functional part of the model. For example, the test method has a characteristic range for possible curvature or part thickness that can be inspected. The geometry provides the actual curvature or thickness of the part at a certain point. If these values match, the inspection regarding curvature and thickness is possible. This has to be performed with all properties in order to gain a full analysis within the model’s scope. In summary, the static part of the model holds all the information or knowledge which is used by the functional part. This information therefore also represents the mechanical and physical parameters of materials and methods.

The functional part of the model connects the characteristics and allows the possibility to work with the stored information. As with a system of linear equations, one entity can be calculated from the other two. A typical request could be: “Which test method

4. The Generic Model - Automated evaluation of test situations

can detect a certain anomaly type for a given geometry?” For example: “Can ultrasonic inspection detect delaminations in a newly designed part?” This follows the idea of semantic data modeling, where information facts are connected with a meaning in order to enable communication and production optimization (ISO/IEC/IEEE, 2012a,b).

In the section above, the formal foundation for the *Generic Model* was created. With the definition of a test situation, parameters to describe geometry, anomaly and test methods were specified. Based on this, a formal grammar and regular language was defined to proof the computability of a test situation. In the following chapter, this is assembled to form the *Generic Model*. First, the principle function is introduced and demonstrated with examples on single aspects before the complete *Generic Model* is presented.

The first step towards the analysis of a test situation is an evaluation regarding the interaction between method and geometry, respectively anomaly. This testability shows, if the inspection of a certain part is possible or not. To do so, for every geometry or anomaly characteristic a corresponding parameter for the test method exists. For example, there is thickness (geometry) and range (method) or interface layer (anomaly) and detectable interface (method). Tables 4.14, 4.15 and 4.16 show possible characteristics that are based on the parameter sets given before. The values can either be just a single value or define an interval (e.g. the range of an inspection method). It is important to mention, that the information in these tables is the library of the model and contains the accumulated knowledge of the users.

With the formal representation of the entities geometry, anomaly and test method, the following paragraph shows how this information is used.

The formal description of the entities was given above. The next step is to explain how the formal relation of this entities work. The basic idea of reaching a conclusion about an inspection is the comparison of the characteristics of the entities geometry, anomaly and test method in order to evaluate possible overlaps. It should be pointed out, that a plain comparison of characteristics might not lead to a useful conclusion. In fact, the model gains it's flexibility and adaptability by the multiple options of making a query. The process of the overall evaluation is an iteration of all single characteristics. As mentioned in 4.2.3.2, finally a performance comparison will give the best options (figure 4.22). To explain this approach, each step will be demonstrated with an abstract and a specific example.

For each characteristic comparison there is a rule, a so called query, which has to be defined. It is obvious, that this definition must lead to a reasonable comparison to get a useful evaluation. For a given entity A the applicability of the second entity B shall be examined. Therefore characteristics A.n have to be compared with characteristics B.m. The result p_i of this comparison must be a boolean “true” or “false”, respectively 1 or 0. This is done by a simple comparison ($<$, \leq , \geq , $>$; eq. 4.11) or an interval test (eq. 4.12) if the characteristic is a range.

4. The Generic Model - Automated evaluation of test situations

$$p_i = \begin{cases} 0 & \neg f(x) \\ 1 & f(x) \end{cases}; f(x) = E_B.n[< | \leq | \geq | >]E_A.m \quad (4.11)$$

$$p_i = \begin{cases} 0 & E_B.n \notin E_A.m \\ 1 & E_B.n \in E_A.m \end{cases} \quad (4.12)$$

p : performance factor

E : Entity of comparison

The combination of static and functional part is able to represent any variety of geometry, anomaly and test method based on the knowledge provided in the statical part.

4.3.1. Example of how to use the Generic Model

As an example, it shall be evaluated if ultrasonic inspection (UT) is suitable to detect anomaly I or II at points P_1 and P_2 in a part made from CFRP (figure 4.20). The required characteristics are shown as an excerpt in tables 4.12 and 4.13.

Now several evaluations have to be done, each one addressing one aspect of the question. To illustrate the approach, it is executed for anomaly type I at point P_1 :

1. Is UT possible on a part made of CFRP

$$E_{geometry.material} \in E_{method.material} \implies p_1 = 1$$

2. Is UT possible at point P_1

$$E_{geometry.thickness} \in E_{method.range} \implies p_2 = 1$$

$$E_{geometry.curvature} \leq E_{method.curvature} \implies p_3 = 1$$

3. Can UT detect anomaly I

$$E_{anomaly.typ} \in E_{method.performance} \implies p_4 = 1$$

4. Can UT detect anomaly at Point P_1

$$E_{anomaly.distance} \in E_{method.range} \implies p_5 = 1$$

As shown in figure 4.22 the single results have to be summarized. To ensure inspectability, the result of all four equations must be “true/1”. But what would happen, if a second anomaly would be less relevant to detect? To give more options a balance factor $k_i \in [0, 1]$ is used to define a testability t_i at each point (eq. 4.13). For $k = 1$ the query is absolutely necessary, otherwise it is optional. It is important, that absolutely relevant

4. The Generic Model - Automated evaluation of test situations

results can bring a summarized overall testability T to zero in order to ensure a clear marking of non inspectable areas (eq. 4.14).

$$t_i = (1 - p_i)(1 - k_i) + p_i \quad (4.13)$$

$$T = \prod t_i \quad (4.14)$$

After the calculation is done with all its iterations, an assessment of the results has to be performed. This assessment must be adapted to the special needs and operational conditions. Basically it has to be a comparison of the results based on the overall performance as explained in chapter 4.2.3.2 for the test method.

The previous paragraph showed how to use the formalized description of geometry, anomaly and test method in order to analyze the testability of a part. Starting with the definition of queries, single characteristics can be compared and then summarized to a overall testability.

As part testability might be the most obvious use case, the model allows in the same way to gain an analysis of one entity out of the two other ones. Figure 4.23 gives an overview of the complete process. Testability evaluation, detectable anomalies or the best suited method are possible results. The process has to be iterated over all possible input information to get the full result. The model also shows a possibility how to integrate feedback from real measurements. Therefore, a match of discrete geometry data and real world scan data is used to build up statistical knowledge.

As the model is not limited to a specific method but solely needs the according data stored in the database, a second example will be discussed shortly for ultrasonic and radiographic inspection. Figure 4.21 shows a part with an undulated surface geometry. As the radii are 3 mm, the curvature criteria for ultrasonic method is not fulfilled (table 4.12: curvature $0, \overline{3\frac{1}{mm}} > 0, 25\frac{1}{mm}$). However, a radiographic inspection (RT) is possible, as seen in the same line of the respective table. For this example it is of interest which anomalies can be detected with a radiographic approach. As material, thickness and range of the radiographic inspection correspond with the values of the example part, line three of table 4.12 shows the detectable anomalies for this part with RT: [delamination, porosity, foreign material].

It is also possible to evaluate the attributes of radiographic inspection with example part one (figure 4.20). The evaluation process is identically to the analysis of UT inspection. Material and abilities, anomaly type and method performance, thickness and method range, as well as anomaly distance evaluations conclude to a positive inspectability with radiographic inspection. In this case, the discussion of paragraph 4.2.3.2 can be used to extend the example to a performance comparison of the methods concerning inspection cost which might lead to a preferred method of inspection.

Both examples showed a rather simple problem. For a production ready system, more complex situations (such as shading of two anomalies, handling a partial match of values or an outskirts anomaly) have to be taken into account for the calculation process. The

4. The Generic Model - Automated evaluation of test situations

Entity	value UT	value RT
method: material	[metal, CFRP]	[metal, metal ALM, CFRP]
method: range	[2-42] mm	[0-150] mm
method: capability	[delamination, porosity]	[delamination, porosity, foreign material]
method: curvature maximum	0,25 $\frac{1}{mm}$	∞

Table 4.12.: These values are a possible excerpt of a knowledge base (method). They provide information about inspection capabilities of ultrasonic (UT) and radiographic (RT) inspection methods. The items are used in combination with information about geometry and anomaly.

Entity	characteristic name	value at P ₁	value at P ₂
anomaly	anomaly I: <u>distance</u> from surface	13 - 13,5 mm	2 - 2,5 mm
anomaly	anomaly I: <u>anomaly type</u>	[delamination]	[delamination]
geometry	<u>material</u>	CFRP	CFRP
geometry	<u>thickness</u>	40 mm	5 mm
anomaly	anomaly II: <u>distance</u> from surface	16 - 18 mm	3 - 4,5 mm
anomaly	anomaly II: <u>anomaly type</u>	[porosity]	[porosity]

Table 4.13.: These values are a possible excerpt of a knowledge base about geometry and anomaly.

example could be easily extended to consider for example shadowing: Ultrasonic inspection might fail to detect anomaly type II at point P₁ due to the shadowing from the delamination whereas a computer tomography inspection might be able to detect both. The model itself sets no limits to this kind of complexity but cannot prevent misinterpretation or misapplication. This kind of guidance must be part of the implementation as a software tool.

4.4. The Generic Model

The previous sections and paragraphs showed the basic elements for the *Generic Model*. Requirements were discussed, the formal language was demonstrated and an example showed, how the principle of the *Generic Model* works. This section gives an overview of the structure, the input and output as well as the boundaries and limitations of the *Generic Model*. Based on the descriptions above, the function of the model will be explained.

Figure 4.23 shows the *Generic Model* as process with the three input possibilities:

4. The Generic Model - Automated evaluation of test situations

parameter name	Class
anomaly name	basic
anomaly density	
type	type
description	
matter (phys.)	
interface	cause
root cause	
time of emergence	

Table 4.14.: Possible parameters for anomaly, that are formally described and analyzed by the model.

parameter name	Class
ID	basic properties
coordinates	
material	material properties
thickness	
curvature	
surface	accessibility
accessibility	

Table 4.15.: Possible parameters for part geometry, that are formally described and analyzed by the model.

geometry, anomaly and test method. This is directly related to the three entities first introduced in figure 4.1 of section 4.2. Starting with two out of these three values as input, the model calculates the third value as output. In addition, the contemplation over time adds the possibility to collect data and make statistical evaluations.

To create the model, the four steps of model building were followed:

1. definition of system boundaries
2. definition of input and output
3. definition of sub-systems
4. definition of system states and system behavior

Each step will be discussed shortly as most of it is a summary of the previous discussion.

4.4.1. System boundaries

The relevant boundaries are the possibilities and limitations concerning design and inspection decisions.

For the design and construction process, the *Generic Model* shall be a supporting tool. It uses a design (CAD file) as input but is not intended to offer design work within the model. It is able to calculate inspection options and displays benefits and downsides of the options, but leaves the decision of choosing the inspection to the user. As the inspection options are calculated, it becomes obvious, where a design is limiting NDT. This information can be used to optimize the design. A close interaction with other tools might be a great possibility for further research. For this first step, the intention of the model is giving an indication of inspection problems to the designer but neither take over nor hinder his work.

4. The Generic Model - Automated evaluation of test situations

A similar approach is done for the inspection. The model uses the knowledge of NDT specialists in a structured way. This leads to a computability of inspection options and helps users to access a wide range of detailed NDT knowledge. The model is also capable of connecting the stored knowledge with real inspection data in order to evaluate designs that often lead to problems. This can be done by statistical functions but could also be a great application for neuronal networks and deep learning. It is important to mention, that the *Generic Model* does not work part specific but (generic) design specific by working with discrete geometry description. Beside the practical advantages this gives the advantage of not doing statistics on one part but on generic design options.

4.4.2. Input and output of the Generic Model

Considering the basics of the *Generic Model* (figure 4.1) the input and output is clearly defined as any two out of the three entities as input and the third as output.

The input, in case of the geometry, is a CAD file and the additional information of table 4.7. By decision, the file format is STL. The approach is similar when defining an anomaly as input. For anomalies table 4.9 is used. The information about NDT methods follows the definition given in table 4.10. Regarding the feedback, a link between the real inspection, its findings and the according element in the simulation has to be provided. Theoretically this can be done by listing the identifying ID of geometry parts but is highly dependent on the software implementation of the model.

The output is quite similar to the input. The model provides information on testability and inspectability regarding the geometry, which could be realized, for example, by a color coded CAD model. Additional information is given in textual form. If the output is supposed to be the anomaly, a CAD model could be used as well. A list of the detectable anomalies should also be provided. For the calculation of possible test methods, the output would be a simple list of the methods in combination with their benefits and downsides. This list can be sorted by these benefits and downsides to find the optimal test method for the situation. In order to find out statistical information of interest, an export to a statistical software could be one option. An ordered list of critical design elements is the minimum requirement in order to use this function of the *Generic Model*.

4.4.3. Sub-Systems

In order to build up the *Generic Model* with all its functions in a software tool, it is useful to divide the model into smaller sub-systems with each having a dedicated function.

One model is needed to import the CAD data of geometry and anomaly. It must collect the file as well as additional information and the intention of the user regarding the further simulation. Another part of the model handles the input about NDT knowledge and stores it in another sub-system such as a database system. A similar function is necessary for the input of statistical data and real measurements. The core of the model is the calculation module where all input data is processed to yield the output. This output must than be displayed. The most complex module here is the visualization of 3D CAD data regarding testability and inspectability. As a sub model this includes the

representation of further information. Also, the output of possible NDT methods must be considered. Already mentioned was an export of the statistical analysis.

4.4.4. Model behavior

The behavior of the *Generic Model* is defined by the formal language defined in subsection 4.2.4. The equations 4.11 and 4.12 in section 4.3 show how this could be realized in detail, which is accommodated by the examples in the same section. Due to this, no redundant information will be given here, however the next section will show a proof of concept by an automated analysis regarding the curvature of a part.

4.5. Principle of automated evaluation

To support the theoretical argumentation, two geometric analyses are presented below.

4.5.1. Example: Curvature analysis of Component

Two digitally represented parts were analyzed with a software algorithm regarding the curvature of its surface. To demonstrate the steps, two differently complex geometries (figures 4.24 and 4.25) have been selected. Figure 4.24 shows a body with simple geometry, which allows a simple analysis. The real component geometry from figure 4.25, on the other hand, serves to test the practical suitability of the procedure. The geometries are available as CAD models using the STL surface representation as triangular mesh.

The procedure for calculating the curvature will be shown first using a simplified two-dimensional example. It has to be considered that the bodies analyzed later are approximated by a surface of single elements (triangles) and not by actually curved surfaces. Thus, the simplified representation can be made by (three) straight lines. The following shows how a curvature parameter is determined for each straight line.

Starting from one element, the two neighbors are considered separately (figure 4.26). The curvature can be described by a circle of curvature which nestles tangentially to the straight line (figure 4.27). The curvature κ is defined as $\kappa = \frac{\Delta\varphi}{\Delta s}$, where φ is the angle associated with the arc s (Hazewinkel, 2013). The Δs curvature circle can be chosen arbitrarily, as, based on $\varphi = const$, the circle arc $s = r * \varphi$ is proportional to radius r . If $\Delta s = 1$ is selected, the result for the curvature is $\kappa = \Delta \varphi$. The angle φ corresponds to the intersection angle of the straight line normal. This procedure must be repeated for all adjacent elements. Finally, the largest angle is selected and assigned to the element under consideration as a value.

In order to apply the shown procedure to solids, the curvature must now be calculated in relation to two planes. Analogous to the previous approach, the curvature circle of the surface normal can be used. This results in the respective angles between the considered element (red) and its neighboring elements (green, blue) in figure 4.28 as intersection angles of the plane normal. Since in the digital representation of the information in STL format for each triangle both vertices and normal are stored directly, this calculation can be carried out very simply.

4. The Generic Model - Automated evaluation of test situations

The following algorithm shows how an entire solid body could be analyzed:

1. do the following steps for each triangle X_n
 - a) Check for each corner (α, β, γ) of the triangle X_1 which neighbors (a, b, \dots, j) exist
 - i. Calculate normal angle between output triangle X_n and each neighbor (a, b, \dots, j)
 - ii. Go to the next corner
 - b) Compare all the calculated angles of the triangle and select the largest angle.
 - c) Assign the largest angle to the considered triangle.
2. go to next triangle X_n

For the representation of the calculation, a color coding is useful in which different colors are assigned to different angles. If this calculation is to be used for an analysis regarding the testability with a certain procedure, the curvature angle must be compared with the maximum permitted angle of the procedure (e.g. sensor parameters like aperture). For each triangle it can thus be decided whether a test (related to the parameter Curvature) is possible.

For both demonstrations parts (figure 4.24 and 4.25), an automatic analysis was carried out and graphically displayed by means of color coding. In Figure 4.29, the different zones can be clearly distinguished on the simple body. The different edge angles and the pointed corners are correctly assigned. Since this was the goal of the simple geometry, the artifacts that can be seen in the graphic, can be ignored here. The reason for this is that the mesh was too coarse when the triangles were divided.

The result for the real part geometry in Figure 4.30 looks more realistic, as the net was chosen sufficiently fine. Planar zones can be easily separated from areas with radii or edges. This shows that the simulation can be extended from a simple cube to real geometries.

For demonstration purposes, an admissible curvature $\kappa_x \leq 30$ has now been defined as the coupling condition for a fictitious test method X . Figure 4.31 shows this condition in color. Elements that exceed the limit value are marked in red. These areas of the component therefore cannot be tested with method X , which can now already be taken into account in the design of the object.

4.6. Summary of chapter 4

In this chapter the very core of this dissertation, the *Generic Model*, is presented. Starting from requirements for such a model, the idea was developed step by step until a proof of concept was shown in a final example.

The requirements are mainly based on the needs from different faculties involved in the design and production process, in order to have a realistic use-case for the final model. After this short entry, the formal basis was discussed. The test situation and

4. *The Generic Model - Automated evaluation of test situations*

a formal language to describe it were introduced and discussed on several examples. This includes also the process of how the final description of geometry, anomaly and test method were developed. The geometry description, based on a surface mesh with triangles and a clear set of characteristics, was proofed to be computable. This proof enables the use of the *Generic Model* for any situation and states that it actually is *generic*. A profound discussion showed how to use the model and considered different example parts and suitable inspection possibilities. Finally, an automated evaluation of the surface curvature was presented. An explanation of the principle as well as the result of a computational model are given.

With the proof of the computability and a proof of concept for an automated evaluation of a test situation, the *Generic Model* is successfully introduced. The possible use-cases and impact on development and production will be discussed in the next chapters.

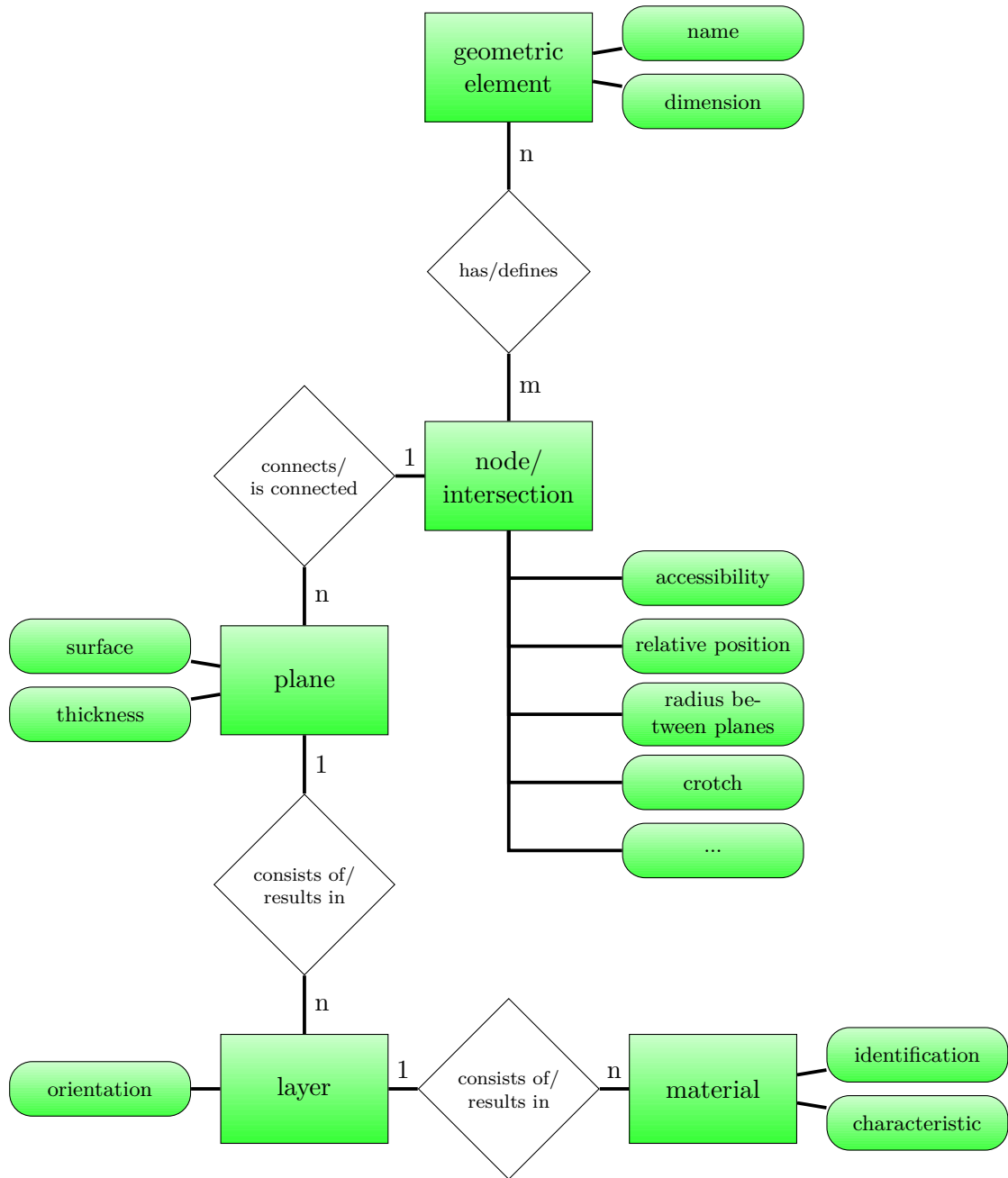

Figure 4.7.: Entity relationship model of geometric elements. An element consists of different properties such as size or material. It is sorted around the idea of connected nodes.

4. The Generic Model - Automated evaluation of test situations

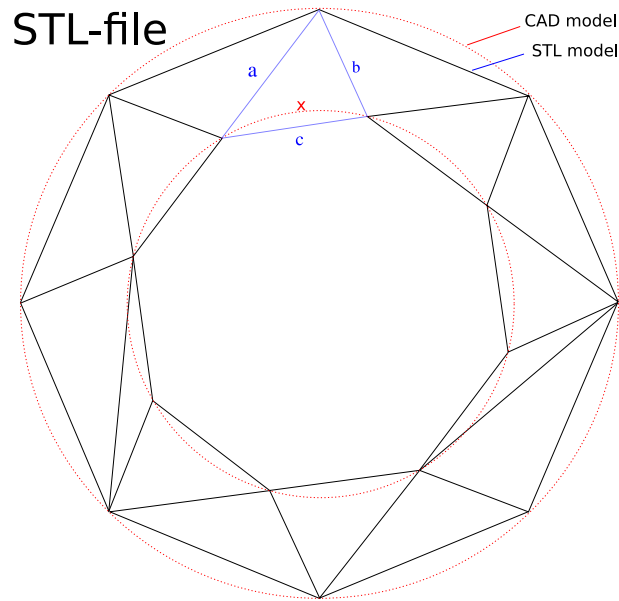

Figure 4.8.: A CAD representation of a torus (shown as two concentric red circles) and an STL approximation of the same shape (composed of triangular planes) (van Lieshout, 2018).

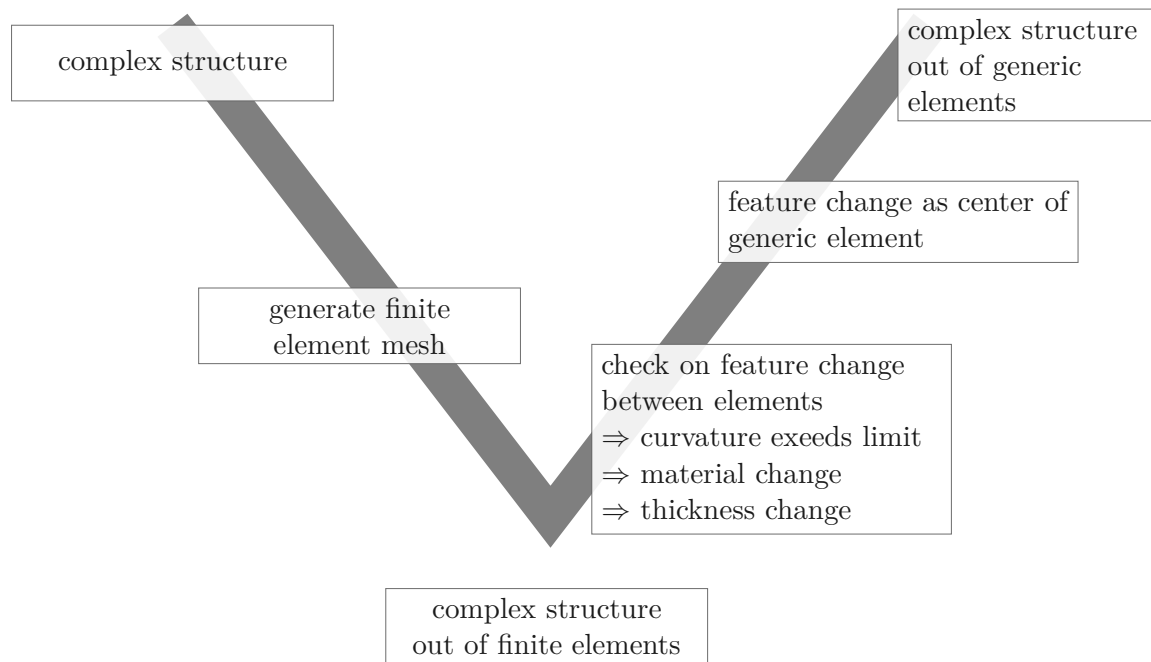

Figure 4.9.: The V-Model of the *Generic Model* connects the computational surface description with human communication about parts and elements. From complex structure to generic elements.

4. The Generic Model - Automated evaluation of test situations

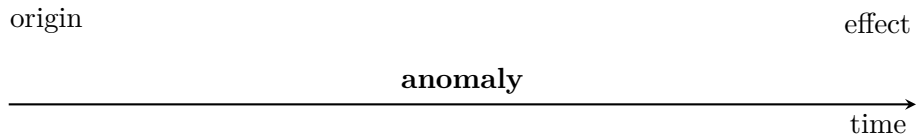

Figure 4.10.: An anomaly always has an origin and an effect. Knowledge about the timeframe can help avoiding the anomaly or set service intervals.

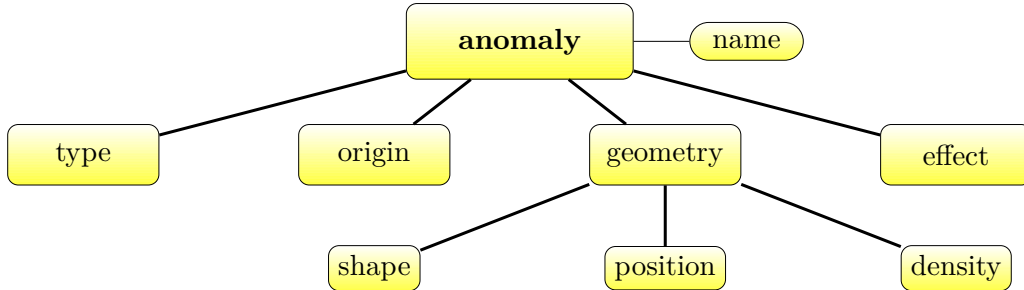

Figure 4.11.: Hierarchy of anomaly nomenclature with basic information about name and type but also more details like origin, effect and geometric information.

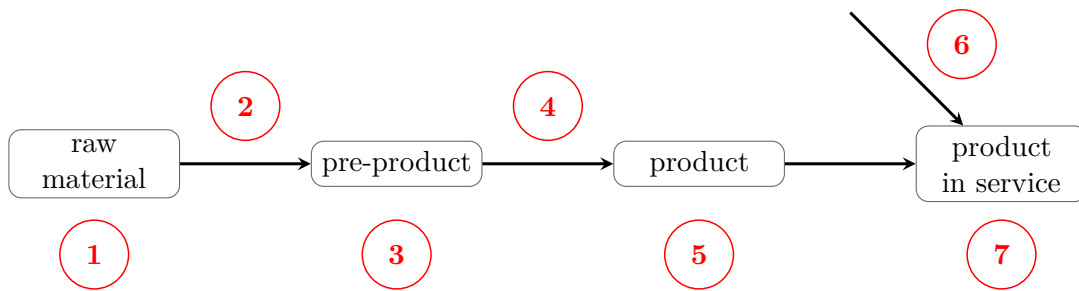

Figure 4.12.: An anomaly can have various origins during production but also in service (compare with table 4.8). The figure shows the alternating emergence and existence of an anomaly and numbers according to 4.8.

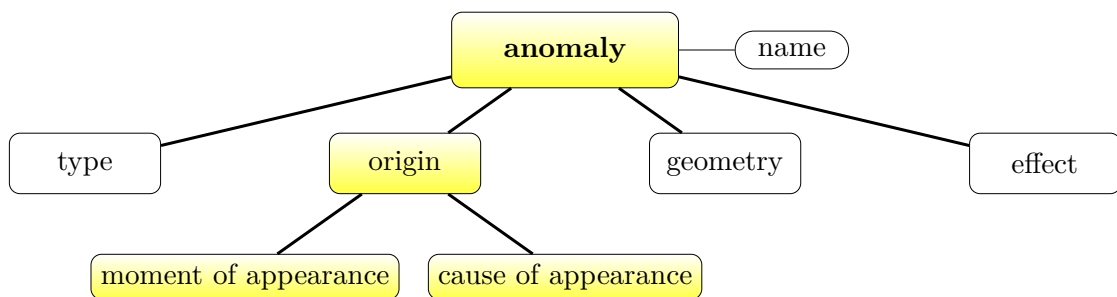

Figure 4.13.: Generic description of the origin of an anomaly. It extends the graph shown in figure 4.11 which already includes geometry information like shape, position and density.

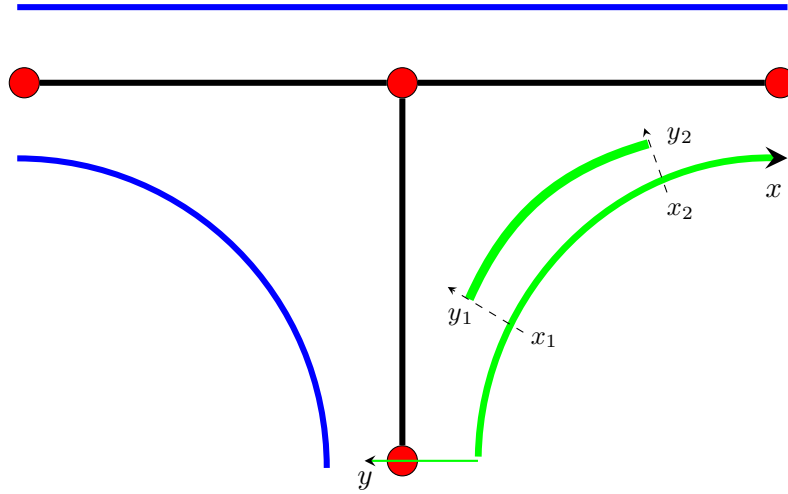

Figure 4.14.: Orientation of a simple anomaly in a part section. The coordinates x_1 and x_2 are marked relatively from the surface, beginning at a node. The position within the part is described with its depth measured from the outer layer (y_1 and y_2).

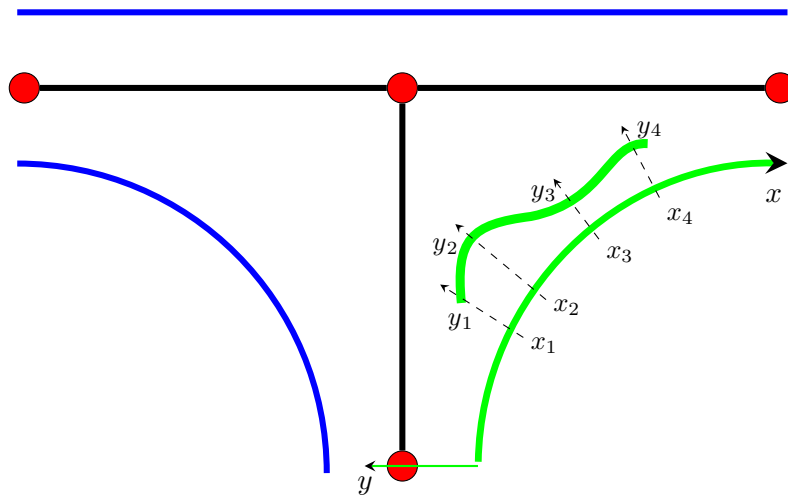

Figure 4.15.: Orientation and position description of a more complex anomaly compared to figure 4.14. The coordinates x_1 to x_4 are marking the position of a depth reference relative to the start node. The values of y_1 to y_4 hold the corresponding depth information.

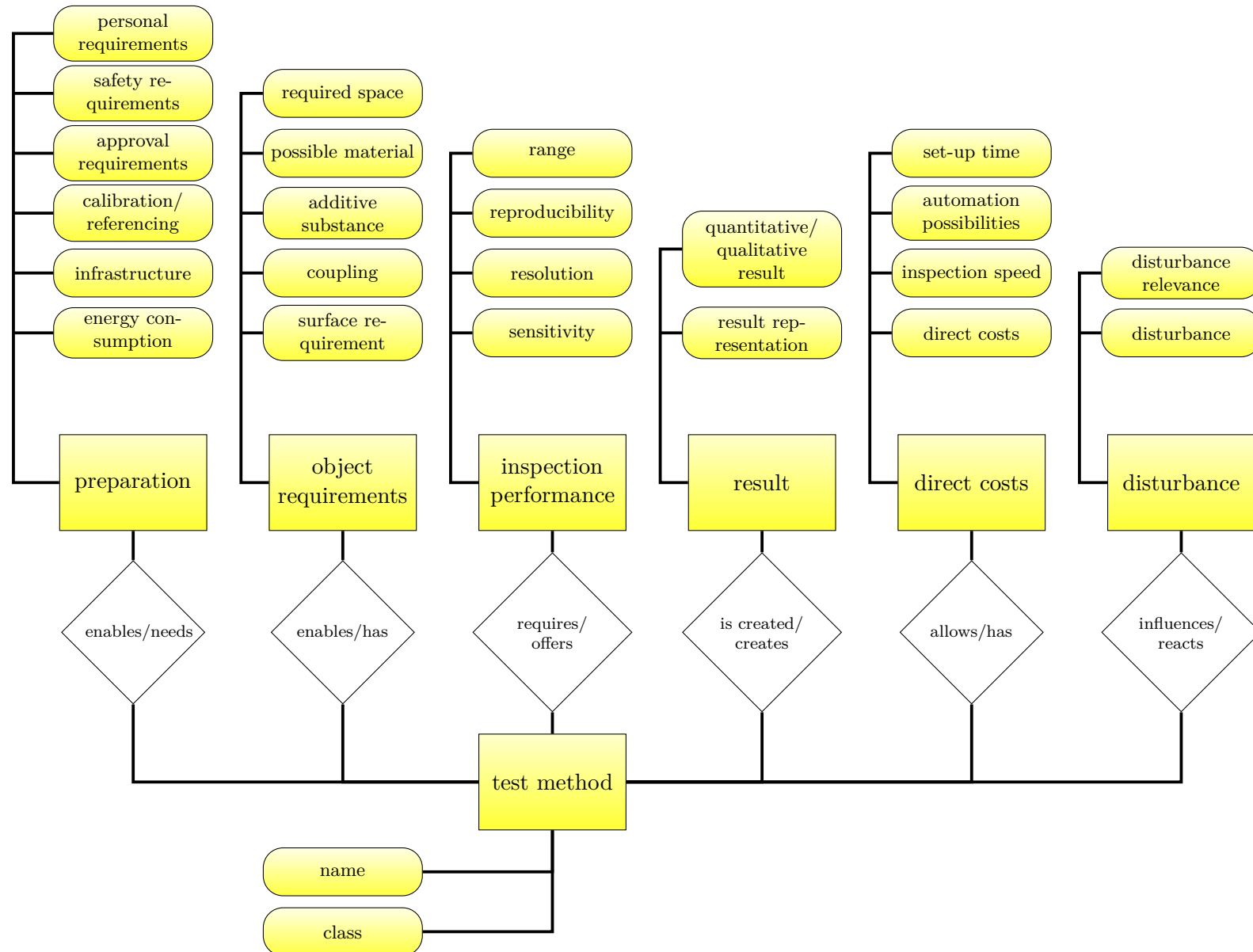

Figure 4.16.: Different properties of test methods are combined into the groups preparation, requirements, performance, result, costs and disturbance. These categories consider varying aspects of the inspection. Further more, one part of the categories are to connect the test method with geometry and anomaly properties, the other part are to compare test methods with each other.

4. The Generic Model - Automated evaluation of test situations

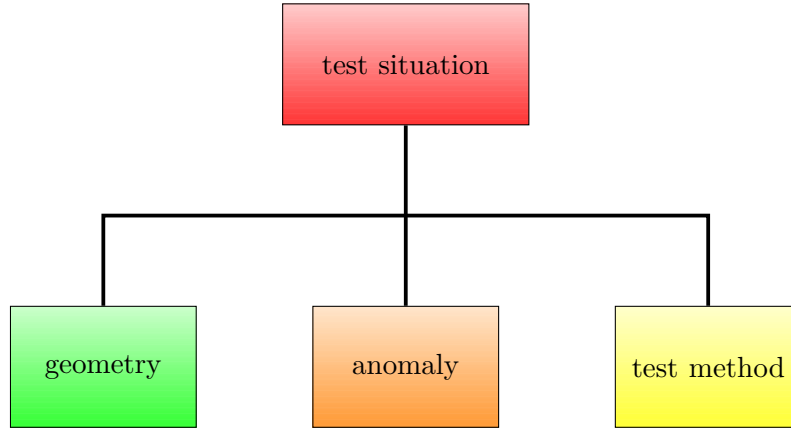
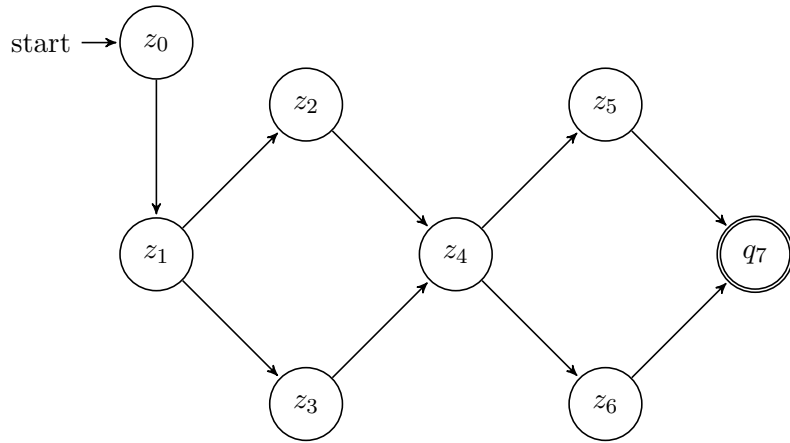

Figure 4.18.: Basic structure of grammar for the *Generic Model*. It defines geometry, anomaly and test method as a test situation.



q.e.d.

Figure 4.19.: A final state machine (FSM) that accepts the language given in equation 4.10 and therefore proof it is regular (a type 3 language).

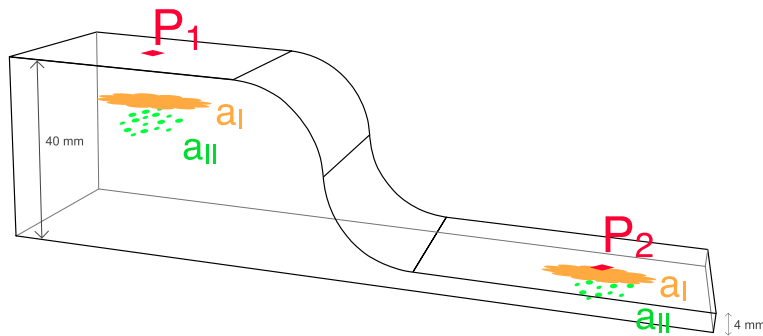

Figure 4.20.: This simple demonstration part visualizes possible inspection scenarios. For example whether anomaly type a_I or a_{II} can be detected at either point P_1 or P_2 .

4. The Generic Model - Automated evaluation of test situations

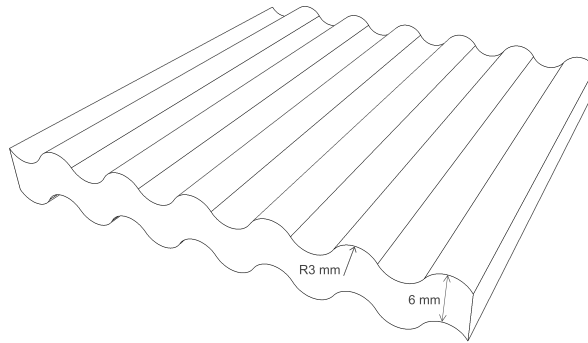

Figure 4.21.: Second demonstration part. The radii of the undulated surface geometry are 3 mm (curvature $0,3 \frac{1}{mm}$). Therefore, ultrasonic inspection is not possible.

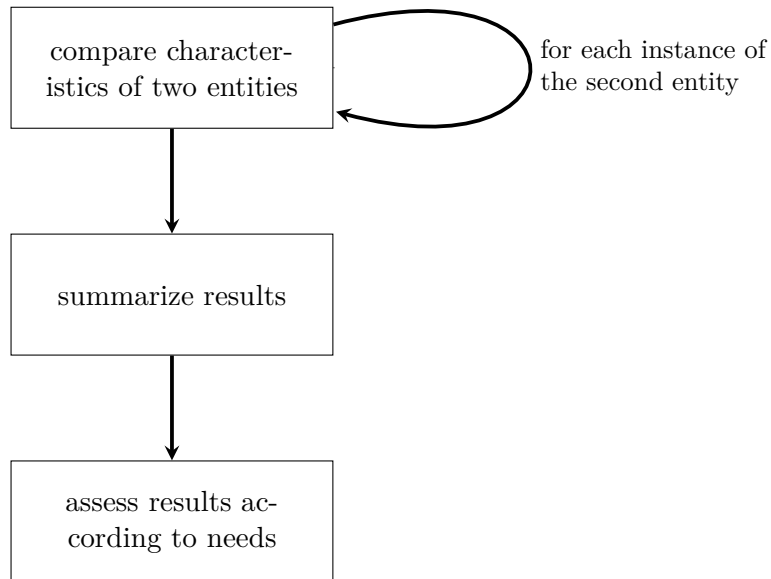

Figure 4.22.: Basic steps to go from a single characteristic comparison to the assessed performance evaluation.

4. The Generic Model - Automated evaluation of test situations

parameter name	Class	
method name		basic parameters
method class		
surface requirement	object requirements	interaction parameters
coupling		
additive substance		
possible material		
required space		
detectable anomalies	inspection performance	
sensitivity		
resolution		
reproducibility		
range		
personal requirements	preparation	performance parameters
safety requirements		
approval requirements		
calibration/referencing		
infrastructure		
energy consumption	result	
result representation		
quantitative/qualitative result	cost	
direct cost		
inspection speed		
automation possibilities		
set-up time	disturbance	
disturbance		
disturbance relevance		

Table 4.16.: Possible parameters for test method, that are formally described and analyzed by the model.

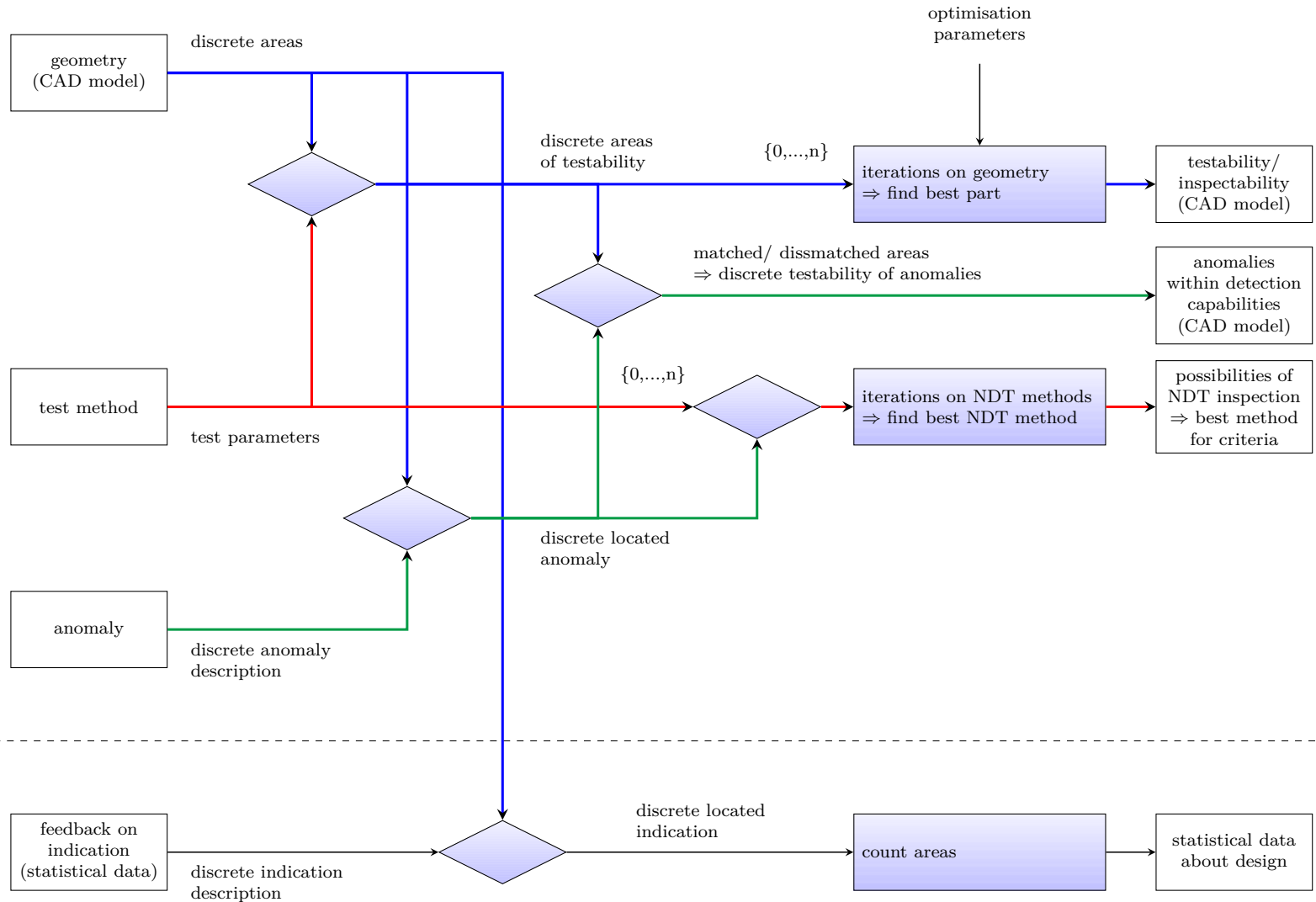

Figure 4.23.: The *Generic Model* as process with different input and output possibilities. Two of the possible three input values (geometry, anomaly, test method) have the third value as output.

4. The Generic Model - Automated evaluation of test situations

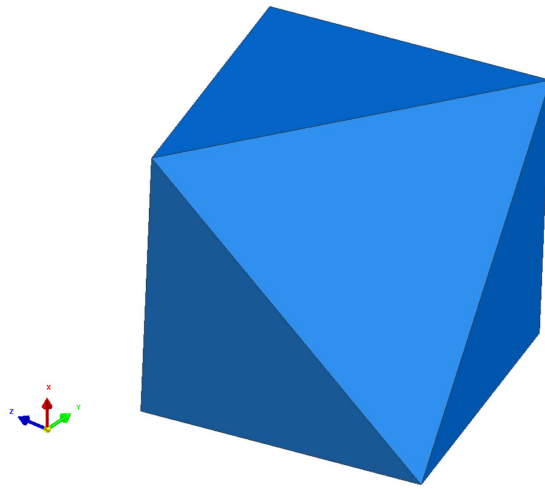

Figure 4.24.: Simple polygon as a demonstration object for the analysis of the curvature of the surface.

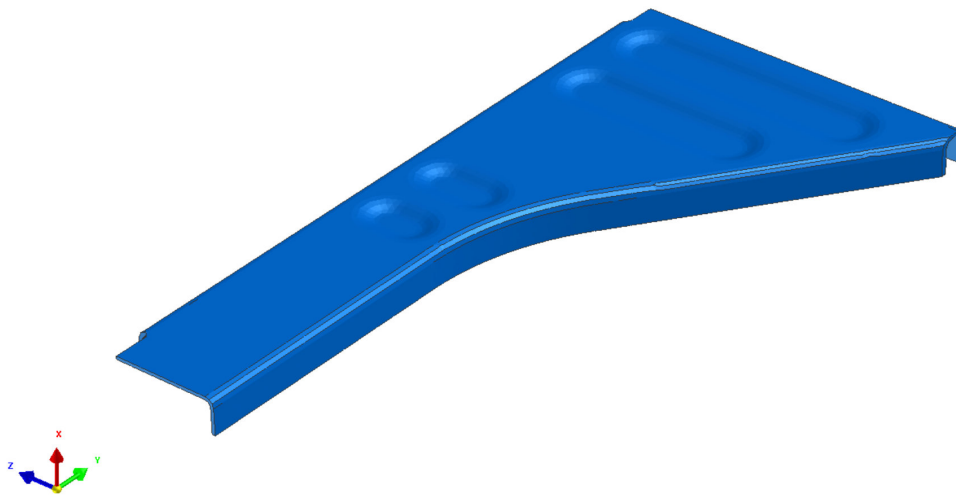

Figure 4.25.: Real component for the analysis of the curvature process and test as practical reference.

4. The Generic Model - Automated evaluation of test situations

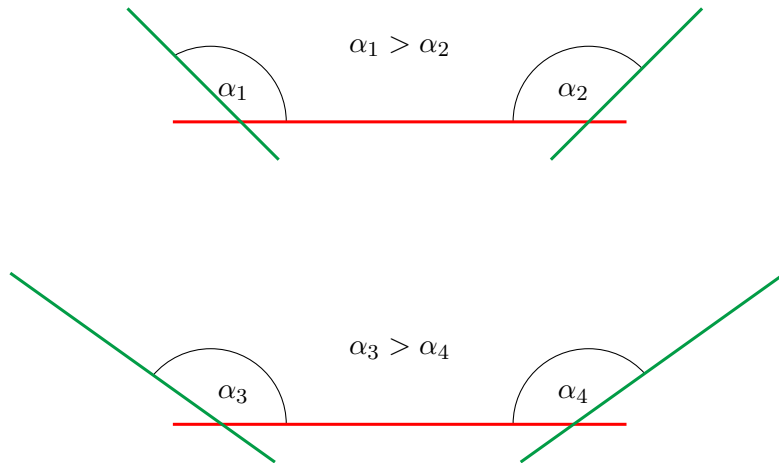

Figure 4.26.: Abstraction of two differently curved surfaces. The analyzed elements are marked red and their neighboring elements green.

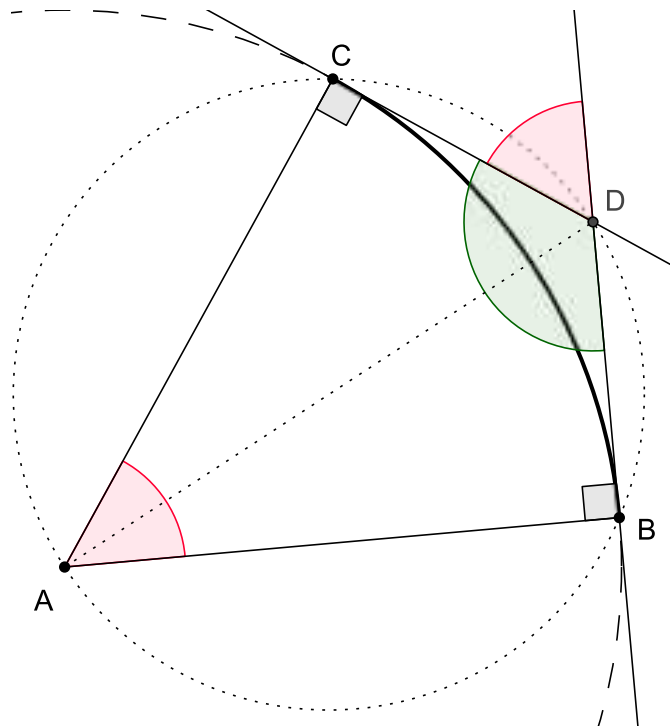

Figure 4.27.: Curvature calculation with curvature circle (Kmhkmh, 2016).

4. The Generic Model - Automated evaluation of test situations

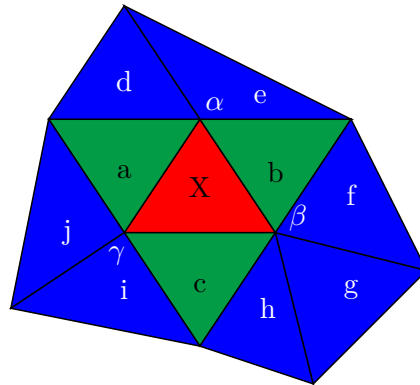

Figure 4.28.: Neighborhood view of a surface represented by triangles. The analyzed elements are marked red and their neighboring elements green and blue.

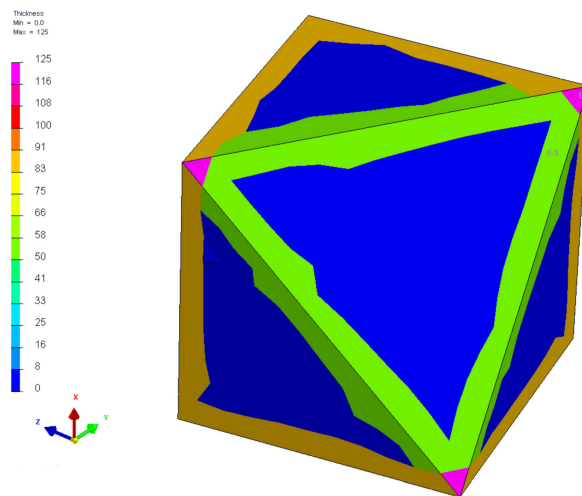

Figure 4.29.: Analysis of the curvature of a simple volume body. The color coding indicates the angle of curvature to the neighboring element.

4. The Generic Model - Automated evaluation of test situations

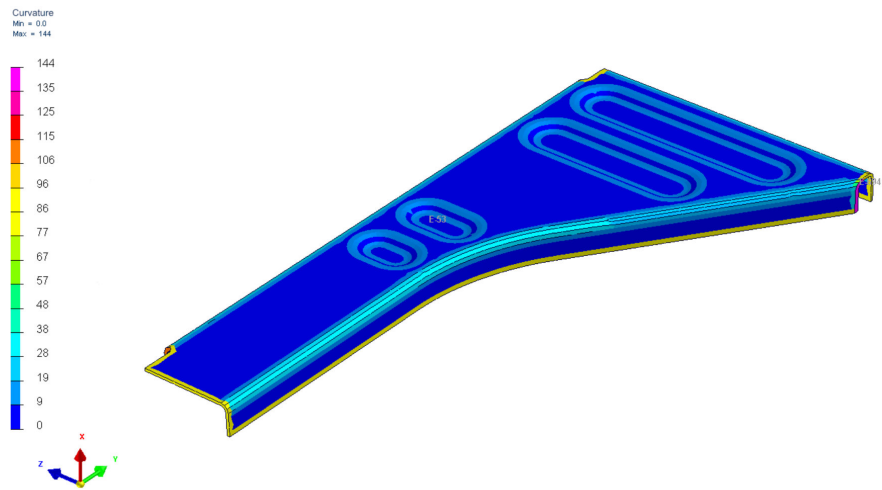

Figure 4.30.: Analysis of the curvature of a real component geometry. The color coding indicates the angle of curvature with respect to the neighboring element.

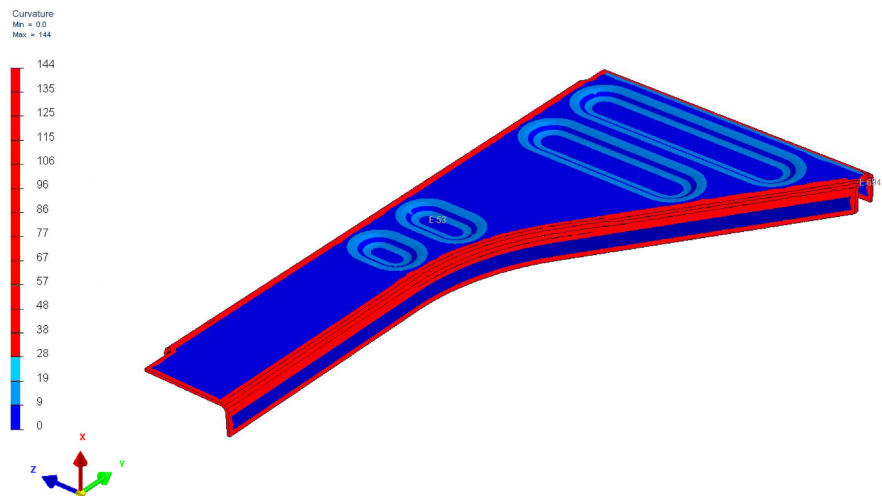

Figure 4.31.: Testable (blue) and non-testable (red) areas of the real component geometry for a fictional test method X and a specifically selected coupling condition: permissible curvature $\kappa_x \leq 30$.

5. NDT as additional degree of freedom during the design process

After creating the *Generic Model* and having shown its function in chapter 4, the possibility of part optimization shall be considered more closely. This chapter shortly connects several information from the previous work and offers a new point of view. The idea is, to combine the requirements of part design and production processes with the possibilities of the *Generic Model*. Two examples on a realistic part show the newly gained degrees of freedom and the potential for optimization.

5.1. Requirement profile and constraint analysis of a part

In order to implement the *Generic Model* for the development and production process, it is necessary to define a requirement profile of the part in this context. Therefore, three relevant topics should be considered: First, a general analysis of how a product or part is developed shall be considered. Subsequently, the relevant influences, requirements and constraints have to be collected. Finally, it is relevant to know who is involved in this processes.

5.1.1. Link with product development

Product development is strongly motivated by competition with competitors (Engeln, 2006), which often leads to cost reduction or product optimization (Ehrlenspiel et al., 2005; Ehrlenspiel, 2007). As stated in paragraph 2.4, this leads to five major subjects in product development:

1. Requirements need to be defined.
2. Methods to handle these requirements and controlling a development or production process are needed.
3. The human factor has to be considered.
4. Communication is an essential part of an efficient processes.
5. A knowledge base works as a foundation for the next iteration of a product and is inevitable to be competitive.

To use the *Generic Model* for part optimization, it has to be linked to this process. Specifically, this means having part requirements as topmost priority. An optimized part, that does not fulfill the requirements would obviously be of no use.

5. NDT as additional degree of freedom during the design process

In order to support the developers, the *Generic Model* has to be adjusted to the existing methods of the design process. One possible approach would be, to see the model as a new tool for this design and development process.

This adjustment goes together with the needs of the involved specialists. This has been an important point for the definition of the *Generic Model*, and becomes relevant again, when implementing it as a tool.

The idea of employing the model as a tool for better communication and its use to store knowledge is consistent with the stated list, too.

5.1.2. Constraint analysis on an example at Airbus Helicopters Deutschland GmbH

The analysis of the helicopter tail boom as described in chapter 3.3 is also a great example to consider design constraints on development and production processes. In chapter 3 the interviews (see A.1) were mainly used to discuss the situation of NDT within the process but they also state already the constraints for product development.

In order to not repeat the previous chapter, just a summary will be given in this paragraph. The analysis of the development and production process can be divided into the three sections “Design & Stress”, “Production” and “Quality Management” purposes (see also figure 3.4). They also define the constraints: In the design phase, the requirements are molded into a part. Material, space, time and cost are typical constraints here, but also the possibilities of production. In production itself, a combination of fundamental possibilities and availabilities (e.g. workers, machines) are relevant. For “Quality Management” there must exist a possibility to check the part for fulfillment of its requirements.

The responsible person for the requirement fulfillment is always the design engineer of the part.

5.2. Design optimization of a part

Below, two examples will be presented. The first example is a part of the LuFo V-1 research project “IPro - Integrierte Gesamt-Prozesskette für Hubschrauber-Oberdeckstrukturen” (Gubernatis et al., 2018). It evaluates three design variants with respect to inspection time. The second example analyzes a part with regarding inspected areas and provides a suggestion for an optimized part.

5.2.1. IPro - upper deck of an helicopter

The discussed part was part of a research project. It is not related to a real product but takes all consideration into account accordingly. The designers came up with three different options (figures 5.1a, 5.1b and 5.1c), that were analyzed regarding different aspects. For this work, only the time for ultrasonic inspection in contact technic (single probe and phased array) is relevant. While variant a and b differ only slightly by the level of part integration, variant c also has an integrated top panel.

5. NDT as additional degree of freedom during the design process

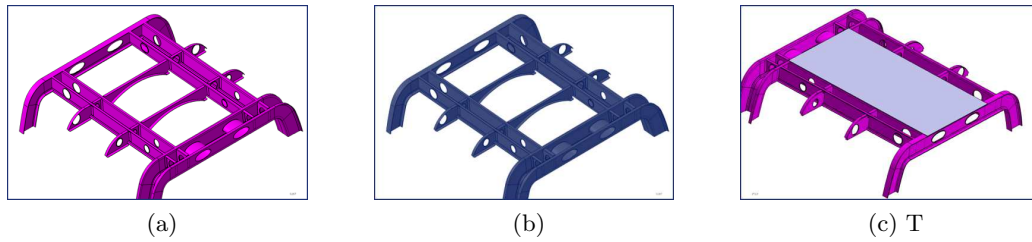

Figure 5.1.: Different design variants (a, b and c) of a helicopter upper deck developed within the IPro research project. The colors only help to differentiate the design variants Airbus Helicopters Deutschland GmbH (2017).

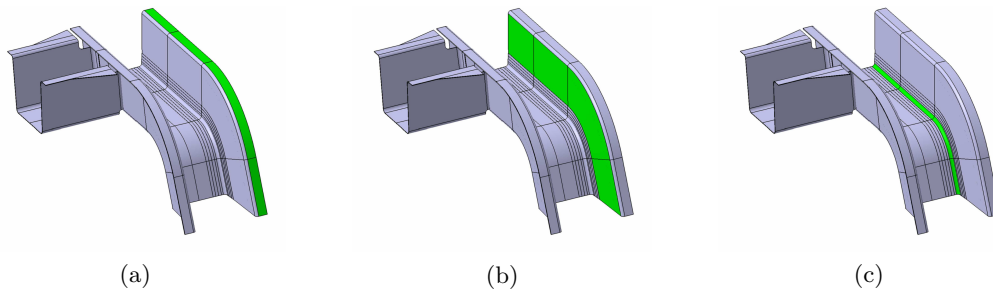

Figure 5.2.: The green marked areas are regions with different inspection requirements. Each area corresponds to an inspection speed and can be used to accumulate the overall inspection time. (a) Small areas, only inspectable by single probe UT. (b) Big areas, that can be inspected with phased array UT. (c) Radii, that have to be inspected with special probes.

To have a simple example, the part was separated in three different categories as shown in figures 5.2a, 5.2b and 5.2c. For each type a scanning speed was calculated and the area respectively the length of the radii were used to accumulate the overall inspection time. As table 5.1 shows, there is around 50 % time difference between variant a and variant c. For a part with a low production quantity, which has to be inspected manually, this links easily to the inspection cost. Using this differentiation on the parts, it can easily be decided, if other variants have benefits that excel the additional time.

5.2.2. Example: optimization of a structural part.

The following part (figure 5.3) is similar to a structural part of an aircraft. For confidentiality reasons, a more detailed description cannot be provided.

Nevertheless, this part shows a lot of critical areas regarding ultrasonic inspection. In the example, the part is analyzed and all non inspectable volume is cut out. In a second step, the part is optimized for inspection (figure 5.4) and again all non inspectable areas will be cut out (ignored). Non inspectable areas are, for example, the back of a T joint. A comparison allows to measure the increased inspectability of the optimized part over the original part. The geometry optimization is done only by adding volume,

5. NDT as additional degree of freedom during the design process

	inspection time i n h		
	variant a	variant b	variant c
flat areas	4,08	5,3	9,07
radii	3,85	4,18	3,33
sandwich	0,89	0,89	1,14
total	9,7	11,4	14,8

Table 5.1.: Comparison of different inspection times of the three design variant in the IPro research project. The time is based on measured average time of an according inspection procedure per area or length on CFRP example parts.

not by rebalancing the structure, as it would be in a realistic scenario. So this example represents a worst case scenario.

Again, the part is separated into different areas and geometry elements similar to the afore mentioned example. This approach follows the V-model of figure 4.9 in chapter 4.2.1.

As table 5.2 shows, a significant improvement of inspectability is accomplished. The inspectable volume could be increased by $\sim 7,5\%$ with less than 2% additional part volume. This leaves an additional inspectable net volume of $\sim 5,5\%$. As all non inspectable volume means no information about the part quality, higher safety margins have to be considered. On the other hand, more inspectable volume offers the chance of weight reduction with the same argument. Beside the increase of the inspectability, also the complexity was reduced. The optimization part has around 50% less corners and about 30% less radii and edge length compared to the original part. In fact, there are no edges at all in the part.

5.3. Summary

The aim of this chapter was to use the previous work in order to have an additional degree of freedom for the optimization in part design. A short aggregation of the development and production process of chapter 3.3 was commented and the focus was set on the constraints of the process. A first example showed how a decision between different part designs was supported by the *Generic Model*. A second, more detailed, showcase used the possibilities of the *Generic Model* to actually optimize the part. Without a second optimization run, an improvement of inspection significance by around 5% of the part volume was possible already. This offers the chance to weight reduction of several percent. Considering the efforts of weight reduction in aeronautics, this is a satisfying result.

5. *NDT as additional degree of freedom during the design process*

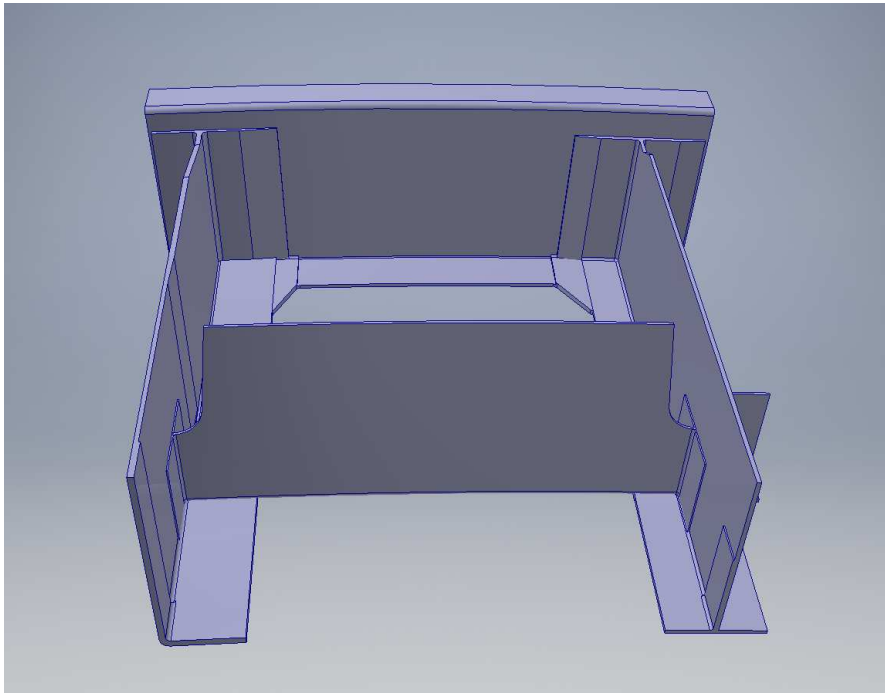

Figure 5.3.: Complex example part of an aircraft. It contains many areas which are difficult to be inspected with ultrasonic inspection techniques. For the considered techniques, a step, a wedge, a change in thickness, a corner or similar shape changes are a challenge to inspect.

5. NDT as additional degree of freedom during the design process

	part before optimization	part after optimization	delta	delta in %
total surface [mm^2]	697446	689291	- 8155	- 1,17
sum flat surface [mm^2]	634427	581567	- 52860	- 8,33
corners	59	31	- 28	- 47,46
radii	43	58	+ 15	+ 34,88
sum length radii [mm]	2522,5	3401	+ 878,5	+ 34,83
edges	75	0	- 75	- 100
sum edges [mm]	2433	0	- 2433	- 100
sum length edges and radii [mm]	4955,5	3401	- 1554,5	- 31,37
total volume [mm^3]	1095572	1116850	+ 21278	+ 1,94
inspectable volume [mm^3]	919379	989018	+ 69639	+ 7,57

Table 5.2.: Comparison of different part designs. A significant improvement by inspectable volume is accomplished by only a minor growth in volume. In addition, the part complexity is reduced.

5. *NDT as additional degree of freedom during the design process*

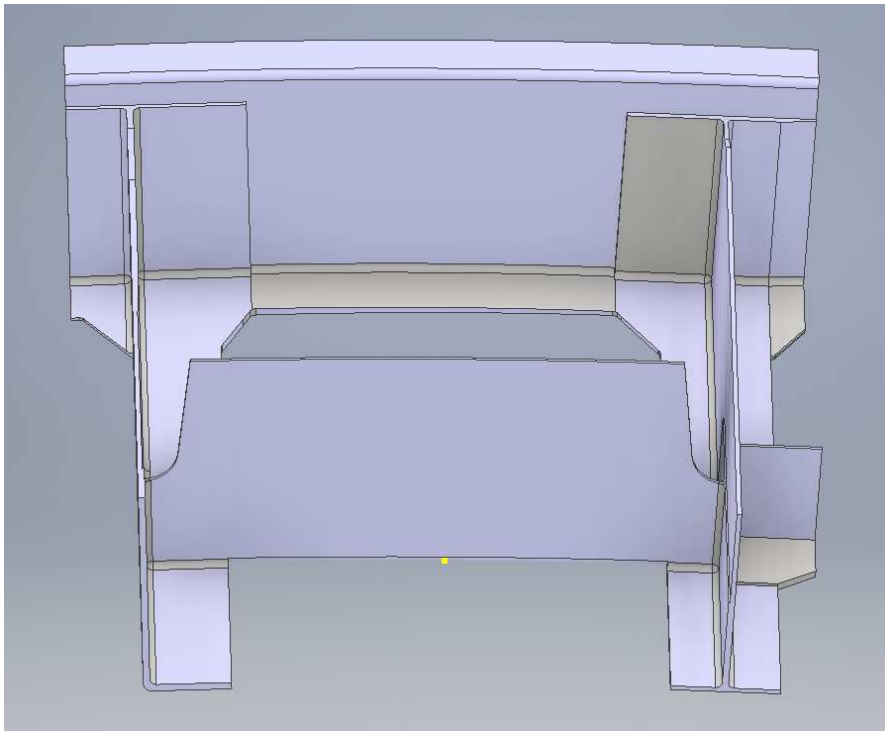

Figure 5.4.: Complex example part after optimization for NDT inspection.

5. NDT as additional degree of freedom during the design process

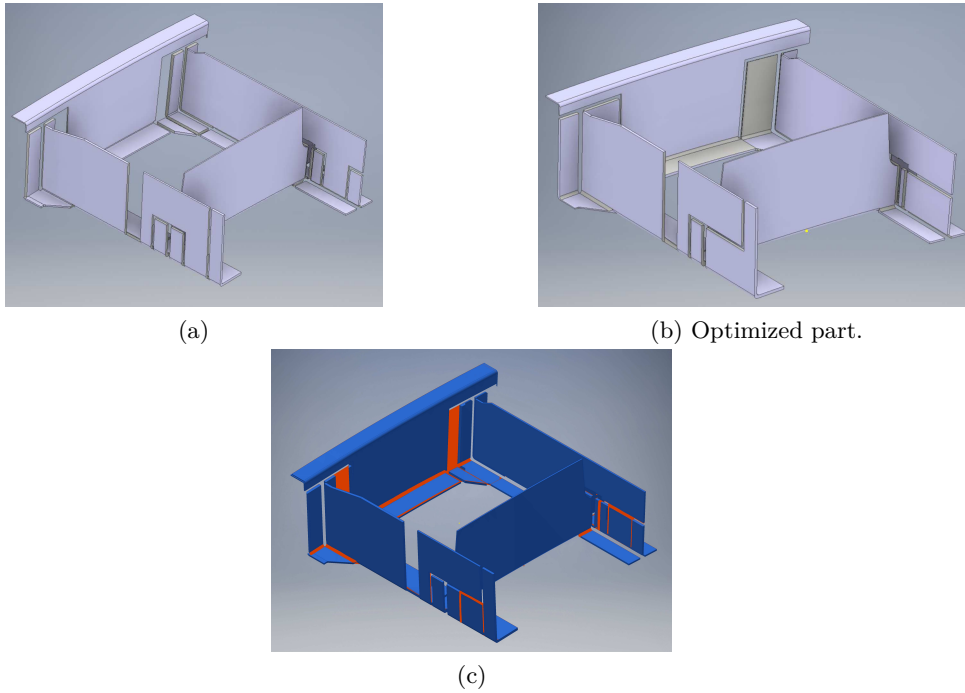

Figure 5.5.: Example part with cut out of non inspectable volume. (a) Part design before optimization, (b) Part optimized for NDT inspection. (c) Optimized part with highlighted differences to non optimized part.

6. Characterization of the relation between origin and effect of an anomaly

Besides all other relevant topics, the character of an anomaly is of crucial importance for NDT. For obvious reasons it is not a desired condition, however information about it is essential to obtain and also to avoid anomalies in a component. *Effect of defect* and *Origin of Defect* is a research field on it's own, but has to be integrated into the *Generic Model*. In the following chapter, this link will be developed.

As already shown in figure 4.10, origin and effect of an anomaly can be set into a temporal relation. Every anomaly has its origin in an incident that happened in the past. This might have been during production as well as in service. The anomaly's origin is the basis for avoidance and prediction of a defect.

The effect of an anomaly on the other hand triggers all future events around the anomaly. Part failure, of course is of major interest. The failure criteria set's the limits of anomaly acceptance and is relevant to avert harm to man and machine. Therefore, in an industrial context, EoD is of interest to everyone who takes care of static and dynamic part stability. Less critical, but also important can be anomalies that have an impact on appearance or similar characteristics.

6.1. Origin and Effect

Classical NDT uses a reaction to an effect of an anomaly. This should not be confused with the EoD regarding the structural calculations as in NDT a physical effect is used to detect an anomaly. Ultrasonic, for example, uses the reflection of a wave while X-ray detects density variations in the part. To further develop NDT, the focus has to be moved to the origin of an anomaly. This is sometimes described as inline NDT and in the current industry 4.0 an important buzz word. However, it does not completely grasp the idea of an anomaly's true origin as reason for its actual emergence. In a perfect situation, the root cause of an anomaly is understood, relevant parameters during production are monitored and deviation corrected in a way that avoids forming of the anomaly.

In order to reach this level of understanding a first step could be to focus on the backtracking possibilities. In case of an anomaly, it's cause has to be discovered as well as the first possibility of its detection (figure 6.1). Regarding the *Generic Model*, this means having a tracking function for anomalies, which raises the question of how to track an anomaly over time.

To principally capture an anomaly, knowing its characteristics is suitable. As the anomaly in the *Generic Model* is connected to the geometry and the method, this should be considered. Knowledge about the anomaly's characteristic is not necessary to describe

6. Characterization of the relation between origin and effect of an anomaly

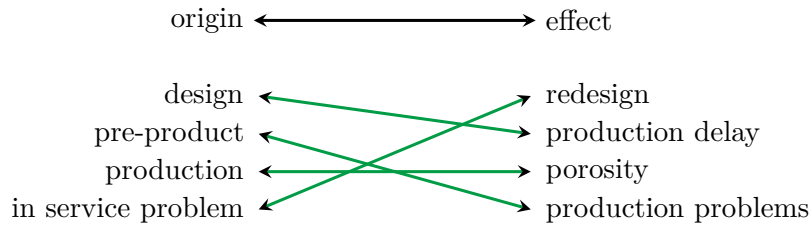

Figure 6.1.: A connection between origin and effect of an anomaly has to be established. This is relevant in order to evaluate an incident and, if necessary, take further action. The given origins and effects are examples and make no claim to be complete but are intended to clarify the initially unclear allocation.

the anomaly, but to point it's first chance of detection. It might have existed already before, but could not be detected earlier. The goal is, as described above, to connect the root cause of the anomaly with its detection. In other words: connect the anomaly origin with the anomaly effect.

To describe an anomaly over time, the easiest way is combining its index number with a time index. In order to trace it back to its origin, every single characteristic has to be traced. By grouping the characteristics, the *Generic Model* enables this retraceability as well as the monitoring over time (figure 6.2).

The abstraction principle shown in figure 6.2 is known as model and instance principle. The model of a characteristic (here the characteristic group) just describes what a characteristic looks like. If it is filled with values, an instance of this model is created. The same model can have many instances which are linked via the group but differ in their values. In this case at least the time index changes. This allows an easy tracking of an anomaly and, if existent, to monitor its change. If used in a software, this digital twin easily allows the implementation of statistical functions on the anomaly progression or points out when and what information on the anomaly needs to be documented.

6.2. Effect of Defect (EoD)

The effect of a defect is evaluated by static and dynamic departments. Especially in production it is mandatory to keep quality insurance and NDT independent of the consequences of their decisions. However, it is important to link the effect of a defect with requirements of NDT and quality insurance: Areas with high impact (high effect of defect) are more important for inspection. A potential software that uses the *Generic Model* should offer an option to define these critical areas, which would make it possible to prioritize these areas in order to ensure their proper inspection.

As a potential future project, this would also give the opportunity of having a learning system which links the origin of an anomaly to a certain geometry in relation to its actual relevance for structural integrity of a part. An approach employing a deep learning neuronal net could be used.

6. Characterization of the relation between origin and effect of an anomaly

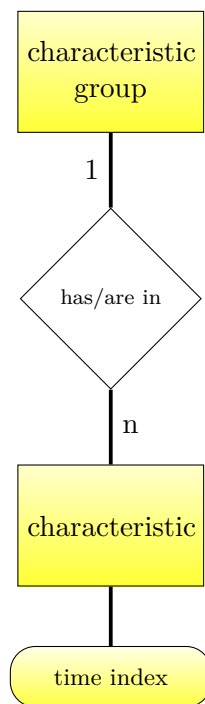

Figure 6.2.: A simple characteristic is abstracted by a group characteristic which holds single characteristics over time.

6. Characterization of the relation between origin and effect of an anomaly

In this context, the influence of three entities geometry, anomaly and test method on emergence or detection of a defect is relevant.

The geometry has influence on the probability of an anomaly in a certain area. This means, the effect of the geometry describes how a certain type of geometry influences the probability of emergence and detection of an anomaly. This can be traced by collection of statistical data of actually detected anomalies and their location in an element. It is important to take into account, that anomalies not detected, will distort the statistic. Nevertheless, this can help to avoid a “bad” design and help to improve construction by showing critical design areas. This is not a core function of the *Generic Model* but could be one of the first evolutionary steps.

The effect of an anomaly characteristic does not describes the effect of the defect but how the characteristic of the anomaly (e.g shape, orientation) influences its probability of detection. This is an information which, if collected, can improve the prediction possibilities of the model. As for the effect of geometry, this has to be described, but not yet completely implemented in the model as it is an enhancement of the core function.

The effect of test performance on the other hand is a core function of the *Generic Model*. It describes how the inspection performance influences the probability of anomaly detection. Chapter 4 and especially subchapter 4.2.3 cover the details on this topic.

Together, the *Effect of Defect* and NDT act as input for statical and dynamical calculation to answer to the question of what a defect means for structural integrity. Depending on this evaluations, the part design might be changed. As NDT provides a probability of anomaly detection (PoD) the *Generic Model* provides better data for the computation and, in the end, a better prediction by PoD analysis. In addition, the *Generic Model* allows to already have this information during the early design process instead of measuring it on the first prototype.

6.3. Avoidance of Defect (AoD)

Generally, avoiding a defect is the ultimate goal. Like EoD this topic is not the core subject of this research but of course is connected with it.

The basic argumentation is based on the fact, that a good inspectability and good documentation of an anomaly helps improving the part design. Again, this leads to better inspection results and a better understanding of an anomaly. If the shape, location and emergence moment of an anomaly are known, the root cause can be found more easily and subsequently be entirely avoided.

For further development of the *Generic Model* and its implementation in a software tool, three topics should be looked at: A function for root cause analysis, statistical methods and a link between the knowledge about the root cause of an anomaly and its prevention.

For the root cause analysis, the moment of emergence is crucial. Also, the shape and further filter functions on the anomaly characteristics might be supportive.

Statistics may be started on the location, the shape and the moment of emergence. The possibility of exporting the data to another analysis software helps to concentrate on

6. Characterization of the relation between origin and effect of an anomaly

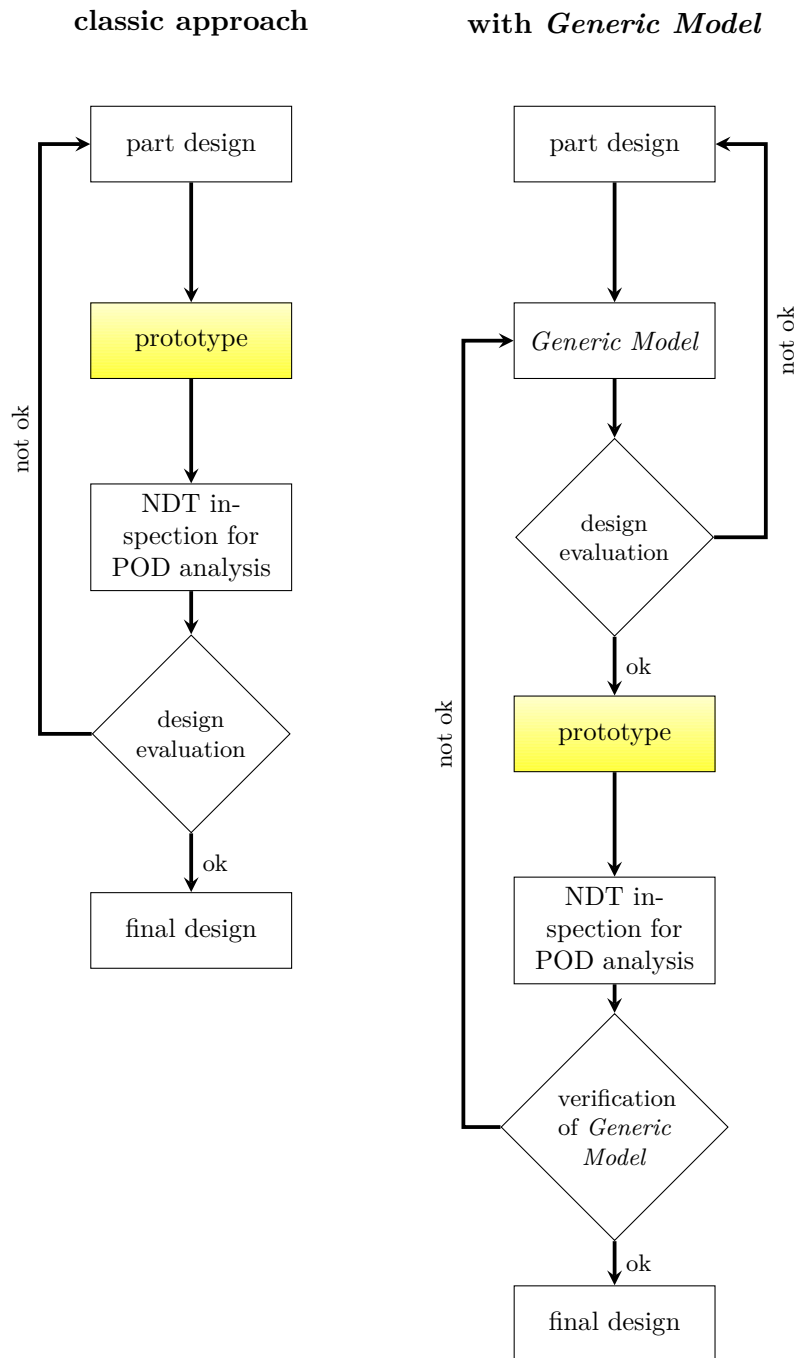

Figure 6.3.: Effect of Defect analysis with and without use of the *Generic Model*.

6. Characterization of the relation between origin and effect of an anomaly

the core functionality of the software instead of rewriting a statistical analysis software. In the end, it must be possible to combine the NDT data with the information of production.

The avoidance of the defect equals the knowledge of the cause. A possible categorization into production based defect, aging and use based defects as well as accident based defects allows different strategy of avoidance. A focus should be on production based anomalies, as they are the most controllable ones but statistics about the other two categories may show vulnerable areas (e.g. to tool drop; a dropped tool on CFRP can cause great damage with no or minimal visible traces on the surface).

6.4. Summary

This chapter shortly discussed origin and effect of defects. Even if not core subject of this work, the implications are relevant. First, the connection between origin and effect of a defect was sketched and set in context of the *Generic Model*. The subchapter 6.2 about the *Effect of Defect* explained the different roles of static and dynamic departments and NDT. An outlook for the *Generic Model* was given and further research opportunities were considered. In chapter 6.3 - *Avoidance of Defect* - further possibilities were discussed and the *Generic Model* was stated as one part of leading to a reduction (or ideally avoidance) of defects. The whole chapter is meant as a context for the model and offers possibilities to make use of it.

Part III.

Software Implementation

7. Implementation of the Generic Model into a software tool for automated evaluation of test situations

In the previous chapters it was suggested to implement the *Generic Model* in a software tool to use it in an industrial context. The next sections draw one possible way of how to realize this.

7.1. Requirements

In a first step, possible requirements are collected. As they might depend on the specific situation, this is not a complete list but tries to give a few hints which requirements might be relevant.

Most important are the needs of potential users. This includes a suitable user interface and a fast response time. A software should be self-explaining. It has to guide a user and actions have to be non-destructive. This means for example preventing data loss by having undo possibilities, show clearly when something is deleted and store settings and configurations automatically.

To fulfill the actual technical task, the element to be evaluated must be provided to the software and an analysis result must be presented to the user, always displaying dimensions and accuracy. As stated before (chapter 4.2.1), the input file shall be a CAD file in the STL format. In addition, certain configuration options must be provided to the user. If as input the test method is chosen, an input form according to the test method description (chapter 4.2.3 and table 4.10) must be available.

Complementary to the input, the output of the computation must be presented to the user in a way, that allows a fast and easy understanding of the test situation. A color-coded CAD part should be the central element. Depending on the calculation, different layers of options should adjust the coloring. For example, a possible output could be *inspectable* and *non inspectable* areas if all available methods are used. By selection of specific test methods the coloring could change to show which areas are inspectable by the selected method. An export function might be useful to further process the data with additional software tools like simulation software.

Besides the user experience and the technical representation, the software must be implemented in an industrial environment which often includes security problems, licensing issues, complex rights management and more. As the *Generic Model* should be available to many different users, a cloud-based approach is suggested. A thin client that can run in a web browser and has access to the backend on a server might be best suited. In any

7. Thoughts on implementing the Generic Model into a software tool

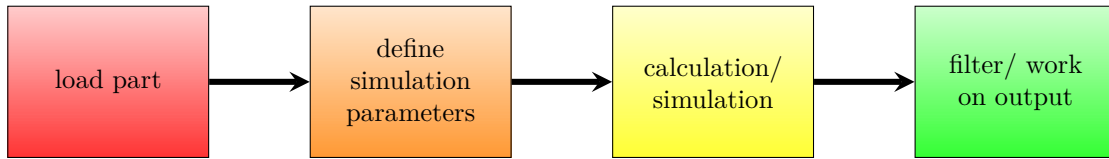

Figure 7.1.: A possible structure of the software split into four major modules. The first and second module handle upload of a CAD file and parameter settings, the third module does the computation and the fourth handles the output and representation.

case it must be a network based software, as different people with different background have to work together and rely on the creation and use of a good knowledge base.

7.2. Possible software structure

Software projects are typically split into several smaller pieces in order to be able to handle the complexity that comes along with it. This can be realized, among other things, by the programming concept (e.g. object oriented programming) or by splitting the software into several modules that are linked seamlessly. Already the discussed requirements lead to a structure of the software that is separated into *input*, *core computation* and *output*. Several independent modules have the advantage of developing them by different programmers or teams. Especially the core computation might be written in a performance oriented programming language where the input and output has a focus on a flexible design. Thereby, the complexity for developing and testing is reduced. It also allows an easy replacement of modules if the requirements change.

A possible structure is shown in figure 7.1. It shows a split into four modules.

The first module has the possibility of selecting a file and gives access to a storage system. It should be possible to upload new CAD files but also to load already uploaded files to continue work. This module must also store additional part information.

The second module collects all the user input and allows to configure the computation parameters. This could also be a starting point if there is no specific CAD part. In this module the decision about test method or anomaly along with the geometry as input for the *Generic Model* has to be made.

The computational module has no direct user interaction but takes the input of the first two modules and does all calculations according to the *Generic Model* by considering the settings, the knowledge base and the given data. Its output is used in the last module to create the result representation.

This representation in module four should have graphical 3D information and a set of filters to analyze the result by the user. Also, as mentioned, an export possibility might be of great use.

Beside this major mandatory modules, statistical tools, controlling the knowledge base and user profiles (with right management) have to be considered.

7.3. Implementation suggestion

In addition to the possible software structure in subsection 7.2, this section provides more specific suggestions about applicable software technologies.

To respond to the need of a multi user software and an easy integration into a company environment, a web based client is suggested. This easily offers the possibility to offer the software as a service. To realize the client and the corresponding part on a server, a framework called *Django* (Django Software Foundation, 2018) based on the programming language *Python* (Python Software Foundation, 2018) is a suitable option. To have a fast and responsive client, the Javascript based framework *Angular* (Google Cooperation, 2018) is a possible option to reduce communication between server and client. Beside the use in the framework, *Python* offers a huge amount of libraries to use readily implemented functionality in the software for the *Generic Model*. As *Python* is widely used in scientific areas this libraries offer very good programming code and typically is open source software.

Compared to hardware near programming languages like *C* or *C++*, *Python* based software is much slower as the code is interpreted during runtime and not precompiled. For the web based tasks however it is fast enough and the flexibility and clear programming outweighs this disadvantage. To implement the core computation, it is possible to switch to faster programming languages like *C*. To switch between both worlds, *Cython* (Behnel et al., 2018) offers an easy way. This language is mostly compatible in writing *Python* but translates the code into the fast language *C*. Even with certain limits, compared to plain *C* code, the functionality is more than adequate. The diagram in figure 7.2 gives an overview over the components.

7.4. Input and Output of the software

After the overview in the previous sections, the following section provides a closer look on the input and output parts. This part of the software represents the interaction with the user and mainly determines its acceptance. A bad user experience makes the rollout of a new software hardly possible.

As stated before, several start scenarios exist. They are the result of the three entities geometry, anomaly and test method. Two out of the three have to be the input, the third is the output. If a user wants to analyze a part existing as CAD file, one request could be to show possible test methods in order to find given anomalies. The other option is to find out, which anomalies can be found in this geometry with a given NDT method. In an according manner, the other input options could be drawn as shown in figure 7.3.

A possible software has to offer these three input options with the three combinations. An easy switch between them without data loss is mandatory. The user might want to try out a few possibilities without reconfiguring the setup.

As for the output the situation is straight forward. For anomaly and test method a list with weighting factors and a possibility to sort the result is a good starting point. Additional filters would improve the situation. The goal must always be to help the

7. Thoughts on implementing the Generic Model into a software tool

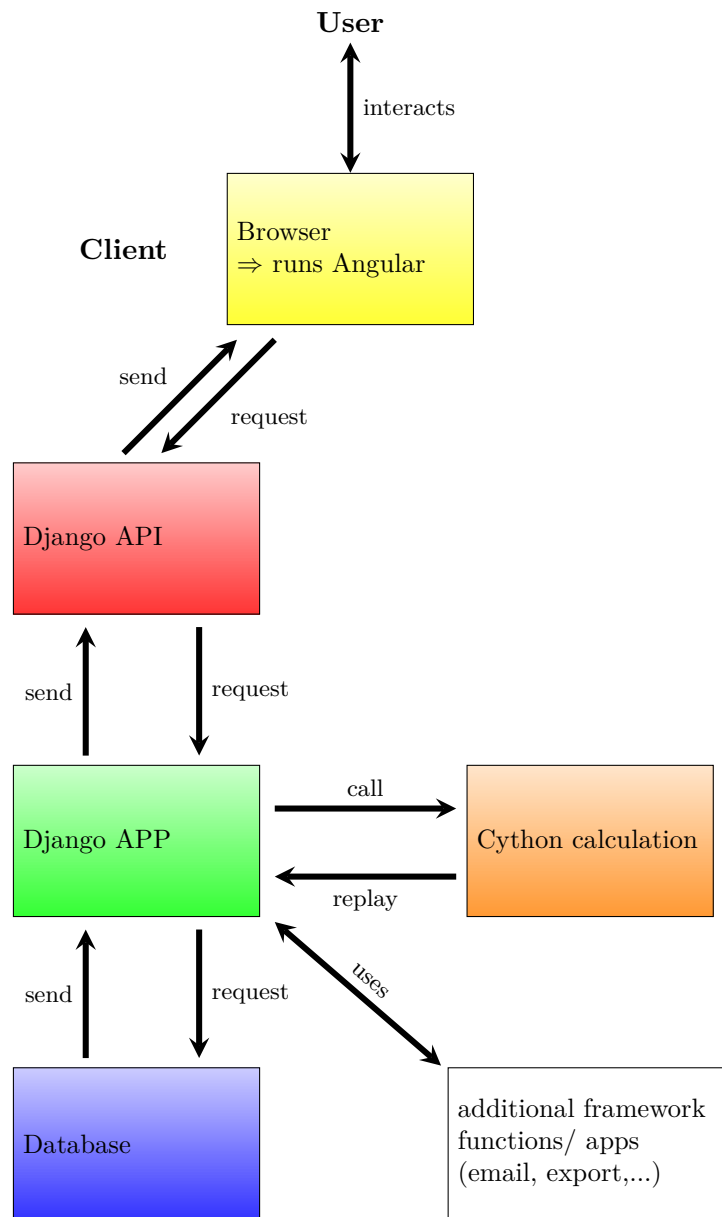

Figure 7.2.: Main components of a possible implementation of the *Generic Model* based on the *Python/Django* framework. To improve functionality and performance, *Angular* and *Cython* are used.

7. Thoughts on implementing the Generic Model into a software tool

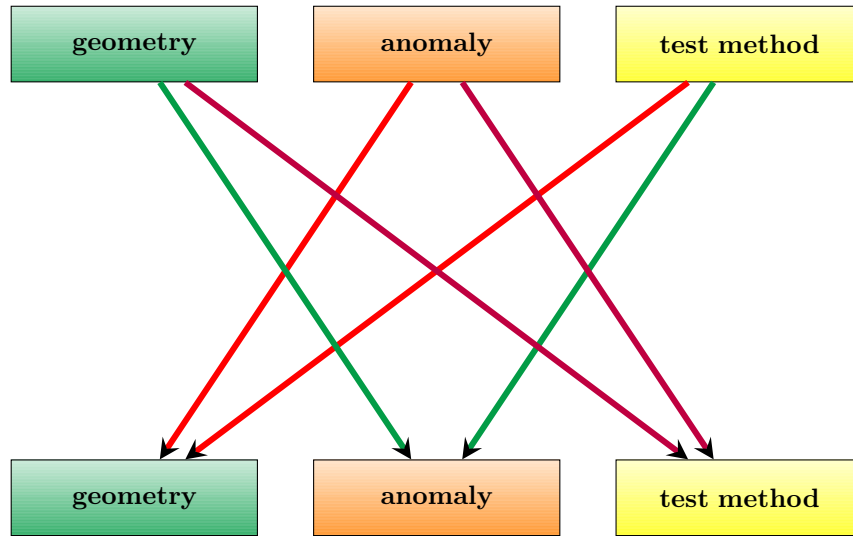

Figure 7.3.: Combinations of input and output situations for the *Generic Model*.

user finding the best suited test method for the situation or balance the risk of different anomalies. For the geometry, the output is slightly more complex. As mentioned earlier, a colored 3D representation would be a great benefit for the user to grasp immediately the questionable areas. This representation should mark by color if a required property can be fulfilled, as presented in the example of the curvature analysis in chapter 4.5.1. The representation should give an overall result but consist of stacked layer representing each property. By activating and deactivating single layers, the user could for the most relevant parameters.

7.5. Summary

In contrast to the other chapters, this one provides specific guidelines for a possible implementation of the *Generic Model* as a software tool and does not deal with the model itself. Beginning with basic requirements, a rough structure of such a software is drawn. The tool is divided into four major parts: The first and second module handle upload of a CAD file and the parameter settings, the third module does the actual computation and the fourth handles the output and representation of results. After this structure definitions, possible programming languages and frameworks are introduced. A combination of Python and C within the framework Django is suggested as a possible strategy. Thoughts about the user interfaces for input and output complete the discussion.

Part IV.

Conclusions and Outlook

8. Summary and Conclusions

To discuss the results of the presented work, first a summary of the theoretical considerations and the achieved results is done. This is followed by a short conclusion in order to prepare the outlook in the last chapter.

The major goal of this research was the creation of a *Generic Model* to connect part development and requirements of NDT in order to improve communication between faculties, have better testability and improve part performance. To accomplish this, a theoretical basis had to be developed and possibilities for an implementation had to be discussed. This work is therefore basically divided into the main part “*Theoretical Consideration*” (part II) and an introduction into “*Software Implementation*” (part III). As the *Software Implementation* is already based on the results of the *Theoretical Considerations* and shows possibilities to put theory into practice, the focus of this chapter will be about the thesis and results in part II.

The overall argumentation is based on a *Situation Analysis of Non Destructive Testing* (chapter 3) which considers different aspects of NDT. Purpose, input and relation of NDT in the overall development and production process was discussed and viewed from different angles. Especially the tracing of one complete component, from the design phase, during production until its delivery, provides a good overview of an industrial environment. The analysis of this process laid the ground for the core of this research, the *Generic Model*, which is presented in chapter 4. This chapter introduces, after a requirement definition, a generic language to describe *test situations*. The *test situation* is the central element of the model. It contains the elements *geometry*, *anomaly* and *test method*. For each entity, a formal representation is developed and set into relation to each other. With the formal definition of each entity and their relations, it is proven that the introduced language is able to describe test situations and is computable as well. The *Generic Model* puts this formal language into a structure which handles two entities of the test situation and leads to a possible answer about the third entity. Several examples in chapter 4 show how the *Generic Model* works and prove its function and usability on real problems. With this positive result, the connection between design, production and NDT can be realized.

A describing language for a test situation was developed and formally proven. It is shown how the *Generic Model* can support designers and NDT personal by offering an automated analysis of a test situation. This is expanded to use the now easily available knowledge about NDT to optimize part design on a long term perspective.

At this point, the main objective of this work can be considered as fulfilled. Chapter 5 and 6 provide further context for the possibilities and implications of the *Generic Model*. The new model is used to optimize part testability and offers a possibility for weight reduction at the same time, which introduces an additional degree of freedom in the

8. Summary and Conclusions

design phase.

It is shown how the *Generic Model* can help to link *Origin* and *Effect of a Defect* and how to use this information to *avoid* defects in the future. Even though a full scale implementation into an industrial environment was not intended nor possible, a solid argumentation suggests that it is feasible and beneficial.

Though the main goal is considered to be achieved, the limits of the model must be addressed and the necessary context of possible applications must be given.

As for any model, the *Generic Model* must take the intended use case into account and when it can be used. In chapters 3 and 4 a lot of constraints were defined for the *Generic Model*. The focus is shifted to the early design process of a part and the possibility to eliminate later NDT problems or at least take them into account. The model itself does not optimize the part design but it gives the designer an additional option for optimization. One could argue, that the *Generic Model* helps to eliminate most of the simple stumbling blocks and leaves time to focus on complex elements of a newly designed part. In addition, the aspect of the common language between departments should support the interaction of the involved persons.

The *Generic Model* stands next to a lot of other possibilities to optimize the development process of a component. At first sight the NDT inspection simulation looks very similar, but on closer inspection it differs fundamentally from the chosen approach. While the simulation examines a calculation of a very specific test case with a concrete method, the *Generic Model* provides a possible selection of methods or an adaptation of the component geometry. The *Generic Model* can give an evaluation about the test possibilities when the NDT simulation shows how the inspection might look like. Of course, a good simulation may provide input for the data basis of the *Generic Model*. In theory, it would also be possible to do simulations with different methods on a given part and evaluate them. This approach should deliver similar result compared to the *Generic Model* but with considerably more effort in preparing the simulation and processing time. The *Generic Model* always has to be seen as an addition to hardware based approaches like destructive testing or tests with prototypes, not as complete replacement. The basic idea of a model, such as the *Generic Model*, is getting a prediction of possibilities and solutions for a problem at an early point in time in order to reduce an effort like building prototypes or having time consuming redesigns. In the end, a produced part has to proof this decision path.

9. Outlook

From the beginning of this work, the focus has been the improvement of industrial production or products itself. Clearly, the chosen strategy was a very theoretical way. The idea was to lay a formal basis for further steps and further research on the one hand and prepare the *Generic Model* to work in industrial processes on the other hand. Due to this, all sections of chapter 5 can be seen as discussion about the possible implications of the *Generic Model*. This covers the chance to see NDT as an additional degree of freedom in the design phase, determine how *Effect of Defect* can lead to *Avoidance of Defect* and possibilities to realize a software tool in order to provide this knowledge to all faculties in the development and production process.

NDT as additional degree of freedom might be the most direct benefit of the given thesis. Following the requirements of an inspection to maximize the significance of its result allows to focus on the areas with impact on the part performance. Balance between a meaningful test result and an easy production offers the chance for cost optimization. If one can rely on precise inspections, the reduction of material margins can lead to weight reduction. As this can be done not only part specific but characteristic specific on every part, cost and weight optimized parts can be developed.

Looking at medium and long term optimization, the understanding of anomaly origin and its actual effect is of interest. The *Generic Model* offers the chance to link this understanding with critical design elements to avoid them or at least point them out. This way problems can be anticipated and counteracted.

Merging this chances and possibilities into a server based software tool will allow technicians, engineers, NDT experts and many more, to work closer together and benefit from mutual knowledge and understanding. At the time of the publication of this thesis, this is addressed at most diverse places as *Industry 4.0*. Among a lot of other aspects, digitalization of processes and creation of transparency are an elementary part of this. With the common language and the formalized process description the *Generic Model* fits perfect into this approach and might be one tool of *Industry 4.0*.

In this context, machine learning and neural networks are mentioned frequently. The strength of these systems lies in the recognition and reproduction of learned patterns. It is certainly a worthwhile undertaking to look at the possibilities of artificial intelligence in the context of the *Generic Model*. One subject could be to feed real inspection data into a learning system to get better predictions about inspection possibilities and the probability where anomalies might be present, always keeping the current limitations of the system in mind.

Another interesting possibility within the scope of *Industry 4.0* lies in the big amount of data that is typically stored (data mining). Regarding a component, this could mean a digital twin with the complete history of the part. Connecting the digital twin with

9. Outlook

the *Generic Model* could open up many new possibilities, as the model stores data about part characteristics itself.

Besides this general consideration, other, more concrete aspects are interesting. As the conclusion in chapter 8 suggests, NDT personal is not being replaced by the *Generic Model* but rather more important. However, the *Generic Model* might change certain aspects of their work. On the one hand, education and training of NDT experts should include this process oriented approach. On the other hand recurring process steps in the daily work of an NDT expert might be simplified. For example inspection specifications are based on information that are already stored in the *Generic Model* during the development process. Using this information could lead to automated creation of inspection and test specifications.

In general, the Generic Model should be seen as a tool to improve products and therefore lead to improved competitiveness.

10. Acknowledgment

First of all, I would like to thank Prof. Christian Große for giving me the opportunity to do this thesis at the Chair of Non-destructive Testing. Thank you for supporting me in following my research interests but for asking important questions and giving advise at the right moments, as well. Many thanks to Dr. Rainhill Freitas for the discussions and the advise. It helped me to focus and stay on track. I'm extremely thankful to Rainhold Oster. I enjoyed every discussion and every project we could work on at Airbus Helicopters. Not only during the PhD but long before, not only about NDT and aircrafts but about all the other things. I admire our way of looking positively on things.

Also, I would like to thank the hole Team of ETLN at Airbus Helicopters, especially Björn Diewel, Gregor Heichler, Manuel Holzheimer, Claudio D'Angelo and Ulrich Baumgarten. It was a lot of work but a lot of fun working with you. Many thanks to Martin Hauf for running and doing Work Breakdown Structures with SMART goals. I also want to thank Theodor Redenbacher for setting me up in this interesting world of helicopters and testing.

I'm very thankful to Airbus Helicopters Deutschland GmbH for making this PhD possible. I'm always turning around when I hear a helicopter and always will.

During all the time I always had the support of my family. I'm very thankful for it. I want to thank my parents, for teaching me the basics that made who I am today. Thank you to my sister and brother. Thank you to my two little girls, who had to accept me writing in the evenings and who had to be quiet during presentations. Looking backwards, we had a lot of times where one of us had a deadline and to finish a project. Thank you to the most understanding and best partner one can think of, my wife Dr. Sybille Fischer.

This work was supported by the project MAIZfP within the leading edge cluster MAI Carbon (<http://www.mai-carbon.de>) sponsored by the German Federal Ministry of Education and Research (BMBF).

It was also supported by the LuFo V-1 project IPrO (Integrierte Gesamt-Prozesskette für Hubschrauber-Oberdeckstrukturen) sponsored by the German Federal Ministry for Economic Affairs and Energy (BMWi).

11. List of Publications

- [1] Mosch M, Oster R, Grosse C. (2016), Non-Destructive Testing of CFRP in the Design Process - a Generic Approach to Describe and Optimize Non-Destructive Testing, 19th World Conference on Non-Destructive Testing (WCNDT), Munich/Germany.
- [2] Zelenyak A-M, Oster R, Mosch M, Jahnke P, Sause MGR. (2016), Numerical Modeling of Ultrasonic Inspection in Fiber Reinforced Materials with Explicit Microstructure. Proc. 19th World Conference on Non-Destructive Testing (WCNDT), Munich/Germany.
- [3] Grosse C, Goldammer M, Grager J.-C, Heichler G, Janke P, Jatzlau P, Kiefel D, Mosch M, Oster R, Sause MGR, Stößel R, Ulrich M. (2016), Comparison of NDT Techniques to Evaluate CFRP - Results Obtained in a MAIzfp Round Robin Test, 19th World Conference on Non-Destructive Testing (WCNDT), Munich/Germany.
- [4] Mosch M, Grosse C. (2017), ZfP Prüfbarkeit an Faserverbundbauteilen. Ein Modell zur automatisierten Bewertung von Prüfsituationen. Deutsche Gesellschaft für Zerstörungsfreie Prüfung (DGZfP), Jahrestagung, Koblenz 21.-24.05.2017.
- [5] Mosch, M. (2018), How to use a Generic Model to Improve Part Quality and Testability. Data-Enabled Discovery and Applications, (2):13, Aug 2018

Bibliography

- Airbus Helicopters Deutschland GmbH (2015). Image tailboom H145.
- Airbus Helicopters Deutschland GmbH (2017). Image upper deck structures.
- Behnel, S., Bradshaw, R., Dalcín, L., Florisson, M., Makarov, V., & Seljebotn, D. S. (2018). <https://cython.org>. Last checked on 05.12.2018.
- Beine, C., Boller, C., Netzelmann, U., Porsch, F., Sridaran Venkat, R., Schulze, M., Bulavinov, A., & Heuer, H. (2010). NDT for CFRP Aeronautical Components A Comparative Study. In *International Symposium on NDT in Aerospace 2010*.
- Bogue, R. (2012). New NDT techniques for new materials and applications. *Assembly Automation*, 32, pp.211–215.
- Born, M. (1965). *Optik*. Springer Verlag Berlin.
- Chomsky, N. (1956). Three models for the description of language. *IRE Transactions on information theory*, 2(3), 113–124.
- Codd, E. F. (1970). A relational model of data for large shared data banks. *Commun. ACM*, 13(6), 377–387.
- Demtröder, W. (2005). *Experimentalphysik 1*. Springer DE.
- DIN-EN-ISO (2015). Quality management systems – fundamentals and vocabulary.
- Django Software Foundation (2018). <https://www.djangoproject.com>. Last checked on 05.12.2018.
- Donahoo, M. J. & Speegle, G. D. (2010). *SQL*. Morgan Kaufmann.
- Duchene, P., Chaki, S., Ayadi, A., & Krawczak, P. (2018). A review of non-destructive techniques used for mechanical damage assessment in polymer composites. *Journal of Materials Science*, 53(11), 7915–7938.
- EASA (2013). *PART-21 - Certification of aircraft and related products, parts and appliances, and of design and production organisation*. European Aviation Safety Agency (EASA).
- EASA (2019). *Foreign Part-145 approvals- Aircraft certifying staff and support staff*. European Aviation Safety Agency (EASA).

Bibliography

- Ehrlenspiel, K. (2007). *Integrierte Produktentwicklung: Denkabläufe, Methodeneinsatz, Zusammenarbeit*. Carl Hanser Verlag.
- Ehrlenspiel, K., Kiewert, A., Lindemann, U., et al. (2005). *Kostengünstig entwickeln und konstruieren*. Springer.
- Encyclopædia-Britannica (2009). SQL. Britannica Academic. <https://academic-eb-com.eaccess.ub.tum.de/levels/collegiate/article/SQL/438617> Last checked on 16.07.2018.
- Engeln, W. (2006). *Methoden der Produktentwicklung*. Oldenbourg Industrieverlag.
- Eversheim, W. & Schuh, G. (2005). *Integrierte Produkt-und Prozessgestaltung*. Springer.
- Google Cooperation (2018). <https://angular.io>. Last checked on 22.09.2020.
- Grosse, C., Goldammer, M. Grager, J., Heichler, G., Jahnke, P., Jatzlau, P., Kiefel, D., Mosch, M., Oster, R., Sause, M., Stöbel, R., & Ulrich, M. (2016). Comparison of NDT Techniques to Evaluate CFRC - Results Obtained in a MAIzfp Round Robin Test. In *19th World Conference on Non-Destructive Testing (WCNDT)*.
- Grosse, C. U. (2016). Modules for an efficient and holistic application of NDT methods for fiber reinforced polymers. In *ECCM17 - 17th European Conference on Composite Materials*.
- Gubernatis, S., Beer, H., & Plaum, J. (2018). *Schlussbericht IPRO - Integrierte Gesamtprozesskette für Hubschrauber Oberdeckstrukturen*. Technical report, Airbus Helicopters.
- Gurari, E. (1989). *An Introduction to the Theory of Computation*. Computer Science Press.
- Hazewinkel, M. (2013). *Encyclopaedia of Mathematics: Volume 6: Subject Index—Author Index*. Springer Science & Business Media.
- HMilch (2008). Schematic X-ray tube. Wikipedia Commons. <https://commons.wikimedia.org/wiki/File:WaterCooledXrayTube.svg>. Last checked on 22.09.2020.
- Hounsfield, G. N. (1975). Penetrating radiation examining apparatus having a scanning collimator. U.S. Patent No. US3866047A.
- Imboden, D. M. (2003). *Systemanalyse : Einführung in die mathematische Modellierung natürlicher Systeme*.
- ISO/IEC/IEEE (2012a). ISO/IEC/IEEE 31320-1: 2012 (Adoption of IEEE Std 1320.1-1998): Information technology – Modeling Languages–Part 1: Syntax and Semantics for IDEF0.

Bibliography

- ISO/IEC/IEEE (2012b). ISO/IEC/IEEE 31320-2: 2012(E): ISO/IEC/IEEE International Standard - Information technology – Modeling Languages – Part 2: Syntax and Semantics for IDEF1X97 (IDEFobject).
- Kain, A. (2014). *Methodik zur Umsetzung der Offenen Produktentwicklung*. PhD thesis, TU Munich.
- Kmhkmh (2016). Kruemmung winkel illustration. Wikipedia Commons. https://commons.wikimedia.org/wiki/File:Kruemmung_winkel_illustration.svg. Last checked on 22.09.2020.
- Krankenhagen, G., Laube, H., & Gottwald, C. (1979). *Wege der Werkstoffprüfung*. Deutsches Museum.
- Krohn, N. (2002). *Nichtlineares dynamisches Materialverhalten zur defekselektiven zerstörungsfreien Prüfung*. PhD thesis, Universität Stuttgart.
- Krüger, G. & Weeber, H. (1983). Die Entwicklung der technischen Durchstrahlungsprüfung in Deutschland. In *DGZP*.
- Lindemann, U. (2009). *Methodische Entwicklung technischer Produkte*. Springer Verlag.
- Mosch, M., Oster, R., & Grosse, C. U. (2016). Non-Destructive Testing of CFRP in the Design Process - a Generic Approach to Describe and Optimize Non-Destructive Testing. In *19th World Conference on Non-Destructive Testing (WCNDT)*.
- Oster, R. (2012). Non-destructive testing methodologies on helicopter fiber composite components challenges today and in the future. In *18th World Conference on Nondestructive Testing* (pp. 16–20).
- Ožbolt, J., Bošnjak, J., G., P., & C., G. (2011). Numerical simulation of concrete exposed to high temperature – damage and explosive spalling. In *2nd International RILEM Workshop on Concrete Spalling due to Fire Exposure*.
- Python Software Foundation (2018). <https://www.python.org/>. Last checked on 05.12.2018.
- Radon, J. (1917). Über die Bestimmung von Funktionen durch ihre Integralwerte längs gewisser Mannigfaltigkeiten. *Berichte über die Verhandlungen der Königlich-Sächsischen Akademie der Wissenschaften zu Leipzig, Mathematisch-Physische Klasse*, 69, 262–277.
- Röntgen, W. C. (1895). Über eine neue Art von Strahlen. *Annalen der Physik*, 300(1), 12–17.
- Sause, M. G. R., Stoessel, R., Oster, R., Soehnchen, R., Jahnke, P., Seemann, A., Goldammer, M., & Grosse, C. U. (2016). MAIZfP: a joint research effort on NDT of fiber reinforced composites within the leading-edge cluster MAI Carbon. In *19th World Conference on Non-Destructive Testing (WCNDT)*.

Bibliography

- Schmiedel, P. & Holzheimer, M. (2016). Development of CFRP Aircraft Doors with the Interaction of NDT and Strength Analysis. In *19th World Conference on Nondestructive Testing*.
- Schöning, U. (2009). *Theoretische Informatik - kurz gefasst*. Spektrum Akademischer Verlag.
- Sellmeier, W. (1871). Zur Erklärung der abnormen Farbenfolge im Spectrum einiger Substanzen. In *Poggendorfs Annalen der Physik, Band 143* (pp. 272).
- Smith, E. (1996). *Elementare Berechenbarkeitstheorie*. Springer Verlag.
- Stoessel, R. (2003). *Air-Coupled Ultrasound Inspection as a New Non-Destructive Testing Tool for Quality Assurance*. PhD thesis, Universität Stuttgart.
- Turing, A. M. (1936). On computable numbers, with an application to the Entscheidungsproblem. In *Proceedings of the London Mathematical Society*, volume 42 (pp. 230–265).
- van Lieshout, L. (2018). The differences between cad and stl models.svg. https://commons.wikimedia.org/wiki/File:The_differences_between_CAD_and_STL_Models.svg. Last checked on 23.10.2018.
- Vary, A. (1973). *Nondestructive evaluation technique guide*. Scientific and Technical Information Office, National Aeronautics and Space Administration.
- VDI (1993). *Methodik zum Entwickeln und Konstruieren technischer Systeme und Produkte*. Guideline VDI 2221.
- VDI (2005). *Classification and evaluation of description methods in automation and control technology*. Guideline VDI 3681.
- VDI (2014). *Simulation of systems in materials handling, logistics and production - Fundamentals*. Guideline VDI 3633.
- Vogel-Heuser (2011). Grundlagen Modellbildung und Simulation. Lecture script - Institute of Automation and Information Systems - TU Munich.
- Vogt, M., Deutsch, V., & Platte, M. (1997). *Ultraschallprüfung*. Springer DE.
- Weiler, K. (1985). Edge-based data structures for solid modeling in curved-surface environments. In *IEEE Computer graphics and applications 5.1* (pp. 21–40).

List of Figures

1.1. Production process with examination at the end. To create a product, a development process is triggered by market and business requirements and implements planning, production and examination steps. Based on VDI 2221 (VDI, 1993).	5
2.1. Reflection and diffraction of a wave at an obstacle H. Based on Vogt et al. (1997).	12
2.2. Vertical impact of a sound wave on the interface of the media (1) and (2). Part of the sound is reflected and another part is transmitted. For reasons of simplification further effects are ignored, however it is important to be aware of $p_E \neq R * p_E + T * p_E$	13
2.3. Sound pressure of a circular radiating surface schematically represented as two-dimensional cut (Based on Vogt et al. (1997)). The subdivision between near field and far field is marked. The darker colors correspond to a higher sound pressure level. For UT inspection, the near field has to be outside of the inspected part. This can be realized by using a transducer wedge.	13
2.4. The sound field generated by transmitter P is compared to the response signal applied over time. A distinction must be made between the input signal S, the backwall echo R and the fault echo F. If an anomaly blocks the complete path, no backwall echo is received.	14
2.5. Correlation of the various result displays for ultrasonic measurements. The A scan is a direct result of the echo as shown in figure 2.4. Mapping this information on a plane results in the C scan (x-y plane) or B scan (x-z plane).	15
2.6. Schematic drawing of an X-ray tube. It produces X-rays by impinging electrons to target area A by using heat voltage U_h and acceleration voltage U_a . To handle thermal issues a cooling liquid W might be used. Based on HMilch (2008).	16
2.7. Principle setup of an X-ray examination. From the X-ray tube emitted primary radiation is directed towards an object. Depending on the object's density and the radiating length, the intensity of the primary radiation on the film varies. This produces the typically grey image of an X-ray inspection. A grid that is aligned with the primary X-rays, reduces disturbances of secondary radiation.	17

List of Figures

2.8.	Refraction and reflection of a wave at an interface according to Snell’s law. The refractive index n_i of the material describes the velocity of light inside the medium i in relation to the velocity of the light in vacuum. . . .	18
2.9.	Functional principle of micro-computer tomography: An irradiated object is rotated in front of the sensor surface. The resulting individual images can thus be combined to form a volume image.	20
2.10.	Chomsky Hierarchy, showing different classes of languages (Chomsky, 1956; Schöning, 2009). From the outside to the center, the languages change incrementally from spoken language to mathematical like languages.	22
2.11.	Deterministic finite automat (DFA) able to accept the example grammar of paragraph 2.2.2. Walking through the graph, every sentence of this grammar can be created.	24
2.12.	Strategies to reproduce a system as a model. Based on Vogel-Heuser (2011).	27
2.13.	Simple example of a table schema. It shows how pupils are connected with a class and which subjects they attend. Subjects are linked with teachers and rooms. It would be possible to find out, which pupils are taught in a certain room or which schoolmaster teaches which pupil. The following tables will list example values.	28
3.1.	Holistic concept for an efficient selection of NDT and SHM techniques in the context of quality control. Based on (Grosse, 2016).	35
3.2.	Different input or boundary conditions which lead to a specific test situation.	37
3.3.	CAD model of a helicopter tail boom (Airbus Helicopters Deutschland GmbH, 2015).	38
3.4.	Development and production process of a helicopters tail boom. Starting with the requirement definition and finishing with the final assembly. The swim lane diagram shows the involvement of design and stress departments, the production process and quality ensurance steps.	39
4.1.	The core of the <i>Generic Model</i> is the static part with the entities geometry, anomaly and test method. The connection of these entities build up the functional part of the model.	46
4.2.	It is mandatory to have two views on the <i>Generic Model</i> : one to describe and talk about parts and one to calculate and simulate.	47
4.3.	A complex part completely made of CFRP with many challenges for a NDT inspection.	48
4.4.	Complex example part with many obstacles for NDT inspection: Corners, edges, wedges, steps and curvature make this part difficult to inspect. . .	49
4.5.	Break down of a complex part into simple elements. The steps from <i>red</i> to <i>green</i> show the original idea which was extended during the research to include finite elements (<i>blue</i>).	50

List of Figures

4.6. Generic description of a structural element in 2 dimensions. With given rules, the nodes are connected by a defined distance, arc and angle. The dimension length “L” should not be confused with “L shaped” geometrical form.	52
4.17. NDT magic cube to benchmark test methods. Test methods can be allocated to a scope group and a physical category. By using a benchmark value for all methods, a comparison between the methods is possible. Switching this benchmark (like a magic/rubik cube) gives a complete picture of the performance.	60
4.7. Entity relationship model of geometric elements. An element consists of different properties such as size or material. It is sorted around the idea of connected nodes.	72
4.8. A CAD representation of a torus (shown as two concentric red circles) and an STL approximation of the same shape (composed of triangular planes) (van Lieshout, 2018).	73
4.9. The V-Model of the <i>Generic Model</i> connects the computational surface description with human communication about parts and elements. From complex structure to generic elements.	73
4.10. An anomaly always has an origin and an effect. Knowledge about the timeframe can help avoiding the anomaly or set service intervals.	74
4.11. Hierarchy of anomaly nomenclature with basic information about name and type but also more details like origin, effect and geometric information.	74
4.12. An anomaly can have various origins during production but also in service (compare with table 4.8). The figure shows the alternating emergence and existence of an anomaly and numbers according to 4.8.	74
4.13. Generic description of the origin of an anomaly. It extends the graph shown in figure 4.11 which already includes geometry information like shape, position and density.	74
4.14. Orientation of a simple anomaly in a part section. The coordinates x_1 and x_2 are marked relatively from the surface, beginning at a node. The position within the part is described with its depth measured from the outer layer (y_1 and y_2).	75
4.15. Orientation and position description of a more complex anomaly compared to figure 4.14. The coordinates x_1 to x_4 are marking the position of a depth reference relative to the start node. The values of y_1 to y_4 hold the corresponding depth information.	75
4.16. Different properties of test methods are combined into the groups preparation, requirements, performance, result, costs and disturbance. These categories consider varying aspects of the inspection. Further more, one part of the categories are to connect the test method with geometry and anomaly properties, the other part are to compare test methods with each other.	76
4.18. Basic structure of grammar for the <i>Generic Model</i> . It defines geometry, anomaly and test method as a test situation.	77

List of Figures

4.19. A final state machine (FSM) that accepts the language given in equation 4.10 and therefore proof it is regular (a type 3 language).	77
4.20. This simple demonstration part visualizes possible inspection scenarios. For example whether anomaly type a_I or a_{II} can be detected at either point P_1 or P_2	77
4.21. Second demonstration part. The radii of the undulated surface geometry are 3 mm (curvature $0, \overline{3} \frac{1}{mm}$). Therefore, ultrasonic inspection is not possible.	78
4.22. Basic steps to go from a single characteristic comparison to the assessed performance evaluation.	78
4.23. The <i>Generic Model</i> as process with different input and output possibilities. Two of the possible three input values (geometry, anomaly, test method) have the third value as output.	80
4.24. Simple polygon as a demonstration object for the analysis of the curvature of the surface.	81
4.25. Real component for the analysis of the curvature process and test as practical reference.	81
4.26. Abstraction of two differently curved surfaces. The analyzed elements are marked red and their neighboring elements green.	82
4.27. Curvature calculation with curvature circle (Kmhkmh, 2016).	82
4.28. Neighborhood view of a surface represented by triangles. The analyzed elements are marked red and their neighboring elements green and blue.	83
4.29. Analysis of the curvature of a simple volume body. The color coding indicates the angle of curvature to the neighboring element.	83
4.30. Analysis of the curvature of a real component geometry. The color coding indicates the angle of curvature with respect to the neighboring element.	84
4.31. Testable (blue) and non-testable (red) areas of the real component geometry for a fictional test method X and a specifically selected coupling condition: permissible curvature $\kappa_x \leq 30$	84
5.1. Different design variants (a, b and c) of a helicopter upper deck developed within the IPro research project. The colors only help to differentiate the design variants Airbus Helicopters Deutschland GmbH (2017).	87
5.2. The green marked areas are regions with different inspection requirements. Each area corresponds to an inspection speed and can used to accumulate the overall inspection time. (a) Small areas, only inspectable by single probe UT. (b) Big areas, that can be inspected with phased array UT. (c) Radii, that have to be inspected with special probes.	87
5.3. Complex example part of an aircraft. It contains many areas which are difficult to be inspected with ultrasonic inspection techniques. For the considered techniques, a step, a wedge, a change in thickness, a corner or similar shape changes are a challenge to inspect.	89
5.4. Complex example part after optimization for NDT inspection.	91

List of Figures

5.5.	Example part with cut out of non inspectable volume. (a) Part design before optimization, (b) Part optimized for NDT inspection. (c) Optimized part with highlighted differences to non optimized part.	92
6.1.	A connection between origin and effect of an anomaly has to be established. This is relevant in order to evaluate an incident and, if necessary, take further action. The given origins and effects are examples and make no claim to be complete but are intended to clarify the initially unclear allocation.	94
6.2.	A simple characteristic is abstracted by a group characteristic which holds single characteristics over time.	95
6.3.	Effect of Defect analysis with and without use of the <i>Generic Model</i>	97
7.1.	A possible structure of the software split into four major modules. The first and second module handle upload of a CAD file and parameter settings, the third module does the computation and the fourth handles the output and representation.	101
7.2.	Main components of a possible implementation of the <i>Generic Model</i> based on the <i>Python/Django</i> framework. To improve functionality and performance, <i>Angular</i> and <i>Cython</i> are used.	103
7.3.	Combinations of input and output situations for the <i>Generic Model</i>	104
A.1.	Area markers for the non-optimized part.	XX
A.2.	Area markers for the optimized part.	XXI

List of Tables

2.1.	Categories of different NDT methods and detectable anomalies according to Vary (1973). To each NDT category, types of possibly detectable anomalies are listed. This does not mean that all listed anomalies can always be found with the method, but it shows which test method reacts to which (physical) effect.	10
2.2.	Classification of possible methods to describe a model. According to Vogel-Heuser (2011) based on VDI (2005).	26
2.3.	Example entries for entity subject.	29
2.4.	Example entries for entity pupils.	29
2.5.	Relationship table of entities pupils and subject.	29
2.6.	Combined tables subject and pupil. The tables are joined via the relationship table 2.5.	30
3.1.	Relevant aspects of NDT methods divided in categories <i>possibilities and expectations, requirements</i> and <i>serial production</i>	36
4.1.	Requirements a <i>Generic Model</i> needs to meet in order to describe NDT test situations.	45
4.2.	Example list for entity "Anomaly" with different attributes.	46
4.3.	Example list for entity "Geometry" with different attributes.	47
4.4.	Example list for entity "Test Method" with different attributes.	47
4.5.	Basic elements to build up an arbitrary part by combining them in different variations. This is meant as an abstract geometry description without units but can be mapped on real dimensions.	49
4.6.	Sequence of basic rules to describe a geometry with connected nodes. . . .	51
4.7.	Parameter set to define the geometry of a part. The coordinates shape the basic triangles. Curvature and thickness give further geometric information supported by material parameters to analyze inspection possibilities.	54
4.8.	Possible origins of an anomaly during production and in service as shown in figure 4.12.	55
4.9.	Parameter set to define the geometry of an anomaly. This is similar to the geometry description of table 4.7 but is extended to include further parameters for anomaly description.	56
4.10.	Possible parameters for test methods, that can be formally described and analyzed by the <i>Generic Model</i>	58
4.11.	Sorting the notation of the grammar in order to have an better overview in the definition of the language.	61

List of Tables

4.12. These values are a possible excerpt of a knowledge base (method). They provide information about inspection capabilities of ultrasonic (UT) and radiographic (RT) inspection methods. The items are used in combination with information about geometry and anomaly.	66
4.13. These values are a possible excerpt of a knowledge base about geometry and anomaly.	66
4.14. Possible parameters for anomaly, that are formally described and analyzed by the model.	67
4.15. Possible parameters for part geometry, that are formally described and analyzed by the model.	67
4.16. Possible parameters for test method, that are formally described and analyzed by the model.	79
5.1. Comparison of different inspection times of the three design variant in the IPro research project. The time is based on measured average time of an according inspection procedure per area or length on CFRP example parts.	88
5.2. Comparison of different part designs. A significant improvement by inspectable volume is accomplished by only a minor growth in volume. In addition, the part complexity is reduced.	90

A. Appendix

A.1. NDT in the overall process - interviews

In order to describe and understand the overall process of the tail boom production mentioned in section 3.3.1 a series of interviews was conducted. When talking to different people, a standardized set of basic questions was asked to find existing and possible interactions with NDT. This procedure started at the end of the production process of the tail boom with a responsible person for the shop area. At the end of the interview, the previous step was inquired, along with a contact person for this step. The focus was always on the main structural element of the tail boom and not on additional attachment parts.

Specific abbreviations in interview documents

CS	Certifying Staff (C/S) means staff authorized by a maintenance organizations to release an Aircraft to service, under the EASA Part-145 approval, following line or base maintenance (EASA, 2019).
EI	internal document type
FM 300	a specific production material
F-Plan	a specific production documentation
QS	<i>German:</i> Qualitätssicherung, Quality assurance

Prozessschritte

PhD:

- ZfP in den Gesamtprozess besser integrieren => Gesamtprozess verstehen
- Beispielhaft an einem Bauteil => Xxxx Heckausleger
- Durchlauf des Bauteils: Entwicklung-Herstellung-Service

Fragen:

1. Was passiert in diesem Prozessschritt?

- Tailboom wird an Zelle montiert (vorheriger Ansprechpartner: Herr Xxxxx Xxxxx)
- Getriebe auf Zelle (Beschlage anbringen)
- Hydraulik / Elektrik
- mech. Verbindungen
- Montage:
 - Wellen (3 teilig; kurz-lang-kurz)
 - Heckrotor nach lackieren
 - Seilnhte werden gepruft
 - schimmen (wird in Frankreich, in Tailboomfertigung und FAL durchgefuhrt)
 - Funktionsprufung
 - => Dichtigkeit
 - => Steuerungseinstellung
 - Spaltma zw. Herumblattern und Ring
 - Antennentest
 - Schraubentausch (Unversehrtheit Lack)

2. Was ist dafür notwendig?

- Material

Tailboom komplett fertig

- Andere Komponenten

- Informationen/ Dokumentation

- Komplette Dokumentation-
- VT -

- Personal

- 1-2 Mechaniker (Montage Tailbone)
- 1 Elektriker
- 1 Elektriker QS

- Fachwissen

Interview FAL
Montage Xxx Tail Boom

Herr Xxxxx Xxxxx
XXXXX

29.09.2015

- Sonstiges

3. Was ist das Ergebnis?

- Material / Produkt
- kompletter Hubschrauber Xxx
- wird an Einflug übergeben => FAL letzter betrachteter Prozessschritt

- Informationen/ Dokumentation

4. Wird ZfP dabei eingesetzt oder vorausgesetzt?

Prozessschritte

PhD:

- ZfP in den Gesamtprozess besser integrieren => Gesamtprozess verstehen
- Beispielhaft an einem Bauteil => Xxxx Heckausleger
- Durchlauf des Bauteils: Entwicklung-Herstellung-Service

Fragen:

1. Was passiert in diesem Prozessschritt?

- Montage Einzelteile (nach Montage Großteile => Lackiererei, danach Statormontage)
- Einsetzen Inserts
- Montage Hitzeschutz
- Messeverbindungen herstellen
- Statormontage
- Winkel für Welle
- A-Profile
- Bearing Support
- Hitzeschutz PR812 montiert
- Beschläge Elektrik
- Spoiler montiert
- Getriebe montiert + Angeschlossen
- Elektrische Einrüstung (Kundenspezifisch => Kabelbaum wird in C1 vorbereitet (=> Herr Xxxxx Xxxxx))
- Anschlusspanel angepasst
- Magnetometerplatte
- Positionslicht
- Griff

- Finnkappe

2. Was ist dafür notwendig?

- Material

- Röhre Heckausleger + Schott (li + re + Verbindung)
- Bauteile größtenteils vorgebohrt
- Aufnahmen für A-Profile => Hydraulik + Elektrik
- Torsionsbleche aufgenietet
- Hauptstadt + Ringspans (schimmen + nieten)

- Andere Komponenten

- Bohrvorrichtungen => Schablonen + Bohren mit autom. Positionshilfe für Holm => Vorschub + Endlage

- Informationen/ Dokumentation

- F-Plan für jeweilige Komponenten => Standard + Optionen => 20 - 50 F-Pläne

- Personal

- Mechaniker
- Elektriker

- Fachwissen

- spez. Schulung für Hydraulikkomponenten

Interview Ausrüstung
Ausrüstung Xxxx Tail boom

Herr Xxxxx Xxxxx
XXXXX

28.10.2015

- Sonstiges

3. Was ist das Ergebnis?

- Material / Produkt
 - montierter + (mit Kundenwünschen) ausgerüsteter X xxx Heckausleger
 - => geht an Xx für
 - Höhenflosse mit Endkappen
 - Lichttest

- Informationen/ Dokumentation

4. Wird ZfP dabei eingesetzt oder vorausgesetzt?

- VT
- Nietprüfung
- Bonding-Messung (je Fügung + am Ende)
- sobald Bauraum verschlossen
 - FE-Prüfung (Finale Endmontage)
 - vergessene Komponenten + Werkzeuge
 - Montage komplett

Prozessschritte

PhD:

- ZfP in den Gesamtprozess besser integrieren => Gesamtprozess verstehen
- Beispielhaft an einem Bauteil => Xxxx Heckausleger
- Durchlauf des Bauteils: Entwicklung-Herstellung-Service

Fragen:

1. Was passiert in diesem Prozessschritt?

A. Cutter

- Laminat ausschneiden
- FM 300
- dünnes Kupfer

B. Lamine legen

- li + re Seite + Halbschalen fügen

C. Vakuumaufbau

D. Autoklav

- 12 h, 3 bar, 0,5-0,8 bar Vakuum

E. Auspacken

F. Sichtprüfung + Q-Schritt

- Protokolle
- Autoklav
- VT Harznester

G. Nachbearbeitung

- Fräsen, Automatisch / Manuell
- möglichst viele Fräsarbeiten, da Absaugung

H. Maßprüfung

Interview Urformung
Urformung Xxxx Tail Boom

Herr Xxxxx Xxxxx
XXXXX

19.11.2015

- einmalige taktile Prüfung für Prozess
- wird Prozess verändert, z.B. NC Programm => erneute Prüfung
- I. UT-Prüfung
 - Schnittkanten
 - gemäß EI/ Prüfanweisung
- J. Lackiererei
 - Grundierung (gelber Lack)
 - Trennschicht zusätzlich bei Kontakt zu AL (grauer Decklack)
- K. Ausrüstung (Vorbereitung)
 - kleinere Vormonaten, z.B. Inserts, Anniemuttern, Senkungen
- L. Abschlussprüfung
 - Klasse 2 => VT; alles dran, alles ok
- M. ggf. Reparaturen

2. Was ist dafür notwendig?

- Material
 - Formen
 - Lagen (CFK/GFK)
 - Wabe
 - Kupferband
 - etc.

- Andere Komponenten

- Cutter

- Informationen/ Dokumentation

- Laserprojektion
- Folienbeschriftung
- Legebuch (Lagen Nr + Material, Position, Richtung)
- F-Pläne
- Prüfanweisungen

- Personal

- Werker
- UT Prüfer

- Fachwissen

- Sonstiges

- Laminieren mit Übermaß
- =>EEOP (finale Fräskontur) und MEOP => Übermaßkontur

3. Was ist das Ergebnis?

- Material / Produkt
- geprüfte Einzelelemente Xxxx Heckausleger
 - Röhre
 - Schott + Deckel
 - Höhenleitwerk
 - Hitzeschutz
 - Wellenverkleidung
 - sonstige kl. Verkleidungen

- Informationen/ Dokumentation

4. Wird ZfP dabei eingesetzt oder vorausgesetzt?

- UT Prüfung: Luft UT, UT in Impuls Echo

Prozessschritte

PhD:

- ZfP in den Gesamtprozess besser integrieren => Gesamtprozess verstehen
- Beispielhaft an einem Bauteil => Xxxx Heckausleger
- Durchlauf des Bauteils: Entwicklung-Herstellung-Service

Fragen:

1. Was passiert in diesem Prozessschritt?

Lastangriffspkt. aus Aerodynamik + Zelle (z.B. Hero Welle)

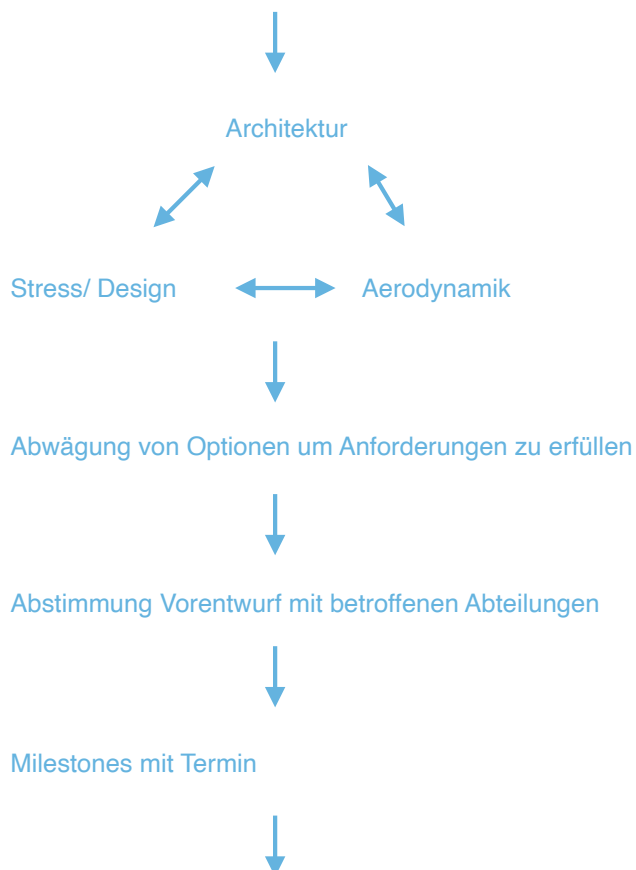

Interview Entwicklung
Entwicklung + Konstruktion
Xxxx Tail Boom
Ausarbeitung Entwurf

Herr Xxxxx Xxxxx
XXXXX

08.04.2016

<= erste Möglichkeit für Einbindung NDT



fertige Konstruktion + Prototyp

2. Was ist dafür notwendig?

- Material

- Dynamisches System
- Kundenumfragen
- Anforderungen anderer Abteilungen
- Aerodynamik
- Vibrationsanalyse
- Wertung

- Andere Komponenten

- Informationen/ Dokumentation

- Design => technische Zeichnung
- only 3D
- Stressdokumente
- Testdokumentation

Interview Entwicklung
Entwicklung + Konstruktion
Xxxx Tail Boom

Herr Xxxxx Xxxxx
XXXXX

08.04.2016

- Nachweisführung Zulassung

- Personal

- Design / Stress

- Aerodynamik

- Architektur

- Fachwissen

- Erfahrung extrem wichtig!

- Sonstiges

- EASA-Dialog für Zulassung

3. Was ist das Ergebnis?

- Material / Produkt

- Prototyp + Erstflug

- Informationen/ Dokumentation

4. Wird ZiP dabei eingesetzt oder vorausgesetzt?

- Dialog mit NDT in Ausarbeitungsschritt

- => wichtig, dass an NDT gedacht wird

- => allerdings keine formale Vorgabe (lediglich indirekt in CS29 => Certification Specification 29 - Large Rotorcraft)

Prozessschritte

PhD:

- ZfP in den Gesamtprozess besser integrieren => Gesamtprozess verstehen
- Beispielhaft an einem Bauteil => Xxxx Heckausleger
- Durchlauf des Bauteils: Entwicklung-Herstellung-Service

Fragen:

1. Was passiert in diesem Prozessschritt?

- Bauteil + F-Plan
 - gibt Prüfzeitpunkt an
 - Vorschriften + Prüfzeichnung + ggf. NC Programm / Prüfanweisung
- Prüfung + Dokumentation (abhängig von Prüfanweisung) => UT-Prüfung / QM-Abschlussprüfung

fehlerfrei	Anzeige
- Stempel in F-Plan	- Markierung auf Bauteil (entsprechend Fehlergröße/Bewertungskriterien)
- Archivierung der Messergebnisse	- Fotodokumentation
	- Q-Meldung erstellen - enthält Foto, Anzeigeart, Verrottung incl. Bezugssystem
	- Sperrung des Bauteile (=>Sperrlager)

Sperrung des Bauteils			
Ausschuss	Reparatur	Anzeige unkritisch	Entscheidung durch MRB - Material Review Board (ggf GPS bei mil.)
	- => Bauabweichung	- => Beuteilabweichung	

Interview Q
Q-Schritt bei UT Prüfung

Herr Herr Xxxxx Xxxx
XXXXX

08.04.2016

	ggf. Standardprozess ohne erneute MRB Entscheidung bei bekanntem Ereignis		
--	--	--	--

2. Was ist dafür notwendig?

- Material
 - UT-Equipment
 - Justierkörper

- Andere Komponenten

- Informationen/ Dokumentation
 - F-Plan
 - Prüfanweisung
 - Bauunterlagen + Prüfzeichnung
 - NC-Programm

- Personal
 - UT-Prüfer
 - Certifying Staff - CS
 - MRB (=>Design, Statik)

- Fachwissen
 - UT
 - Design
 - Statik
 - Bauteilkenntnis

- Sonstiges

3. Was ist das Ergebnis?

- Material / Produkt

- geprüfetes, nicht ausgerüstete Bauteile (=>Röhre, Shroud, Shrouddeckel)

- Informationen/ Dokumentation

4. Wird ZfP dabei eingesetzt oder vorausgesetzt?

- ZfP Schritt :-)

A.2. Comparison of a non-optimized and an optimized part

In section 5.2 a given part geometry was optimized for better NDT inspection. Several parameters, such as surface, the volume or the amount of edges, were compared as shown in the following tables and figures.

Non-optimized part:

#	1	1.5	2	3	4	5	6	7	8	9	10	11+14	12
# Area	51739	4112	42501	4595	3537	3720	3780	50451	2920	2920	4320	18432	2187
total surface in mm^2													
# corners	2	1	4	1	1	1	1	3	1	1	0	3	1
# radii	2	0	3	1	1	1	1	1	0	0	1	2	1
length in mm	62+62	0	5	131	132	124+30	126	126	0	0	30	57+31	66
sum length in mm	124	0	494	131	132	154	126	126	0	0	30	88	66
#edges	2	3	6	1	1	0	1	5	2	2	0	5	1
length in mm	30+49	73+32+	135+10					114+73				114+64	
sum length in mm	79	129	735	34	27	0	30	563	113	113	0	428	34

Optimized part:

#	1	2	3	4	5	6	7	7.5	8	9	10	11	12
# Area	51546	3492	38525	4458	8543	6880	3660	49042	2881	2010	9834	14879	1769
total surface in mm^2													
# corners	2	1	2	1	1	1	1	3	1	1	1	0	1
# radii	4	2	1	2	2	2	2	2	2	2	2	0	2
length in mm	51+67+	56+71	228	38+135	70+132	60+126	33+126	314+12	47+71	34+71	122+67	0	33+65
sum length in mm	217	127	228	173	202	186	159	436	118	105	189	0	98
#edges	0	0	0	0	0	0	0	0	0	0	0	0	0
length in mm	0	0	0	0	0	0	0	0	0	0	0	0	0
sum length in mm	0	0	0	0	0	0	0	0	0	0	0	0	0

13	11+14	15	16	17	17.5	18	19+22	20	21	23	24	25	26	27
2083		28059	70426	52093	4112	60079	49009	2083	2204	1914	13859	1471	816	768
1		1	0	2	1	1	4	1	1	0	0	1	1	1
2		1	1	3	0	1	3	2	1	1	0	0	0	0
63+31		131	480	63+353 +63	0	131	124+25 8+58	63+31	62	29	0	0	0	0
92		131	480	479	0	131	440	94	62	29	0	0	0	0
0		1	0	0	3	1	5	0	1	0	0	2	2	2
0		197	0	0	73+32+ 24	73	65+72+ 65+66+ 29	0	33	0	0	22+75	34+24	32+24
0		197	0	0	129	73	297	0	33	0	0	97	58	56

13	14	15	16	17	18	19	20	21	22	23	25	26	27	28
27368	68811	51140	3492	60072	42724	3782	7434	13671	7857	1560	3103	29487	11071	3304
1	0	2	1	1	1	1	1	0	1	1	0	2	2	1
2	1	3	2	2	2	2	2	0	2	2	0	3	3	2
201+13		65+358			230+12							230+35	60+358	
2	471	+65	56+71	78+134	6	66+65	122+67	0	55+230	56+34	0	8+264	+33	33+122
333	471	488	127	212	356	131	189	0	285	90	0	852	451	154
0	0	0	0	0	0	0	0	0	0	0	0	0	0	0
0	0	0	0	0	0	0	0	0	0	0	0	0	0	0
0	0	0	0	0	0	0	0	0	0	0	0	0	0	0

	28	28.5	29	30	31	32	33	34	35	36	37	38	39	40	41	42
768	5042	8090	10967	3888	1569	8861	1116	13001	6163	2195	14330	23720	16927	8232	10626	
3	2	2	2	3	2	2	2	2	3	1	0	0	0	0	0	0
0	0	2	3	2	1	1	1	1	2	0	1	0	0	0	0	0
0	0	30+260	31+356	58+29	5	227	9	33	57+30	0	480	0	0	0	0	0
0	0	290	418	87	5	227	9	33	87	0	480	0	0	0	0	0
4	3	1	0	2	2	2	2	3	2	2	0	0	1	2	2	2
30+221	32+40+															
+40+32	114	31	0	35+30	75+22	40+40	11+75	49+227	34+51	73+39	0	0	49	33+33	69+69	
323	186	31	0	65	97	80	86	323	85	112	0	0	49	66	138	

	29	30	31	32	33
5546	1616	14138	66622	8236	
1	1	0	0	0	
2	2	1	0	0	
51+122	76+38	471	0	0	
173	114	471	0	0	
0	0	0	0	0	
0	0	0	0	0	
0	0	0	0	0	

total optimized part	
630609	0,6306 m^2
34	
60	
3619	3,619 m
0	
0	0 m

43	44
6324	8418
0	0
0	0
0	0
0	0
0	0
0	1
0	69
0	0

total non-optimized part	
634427	0,6344 m^2
59	
43	
2522,5	2,5225 m
75	
2433	2,433 m

	part without optimization	part with optimization	delta	delta in %
total surface in mm ²	697446	689291	8155	-1,17
sum surface in mm ²	634427	630609	3818	-0,60
# corners	59	34	25	-42,37
# radii	43	60	-17	39,53
sum length in mm	2522,5	3619	-1096,5	43,47
#edges	75	0	75	-100,00
sum length in mm	2433	0	2433	-100,00
Volume in mm ³	1095572	1116850	-21278	1,94

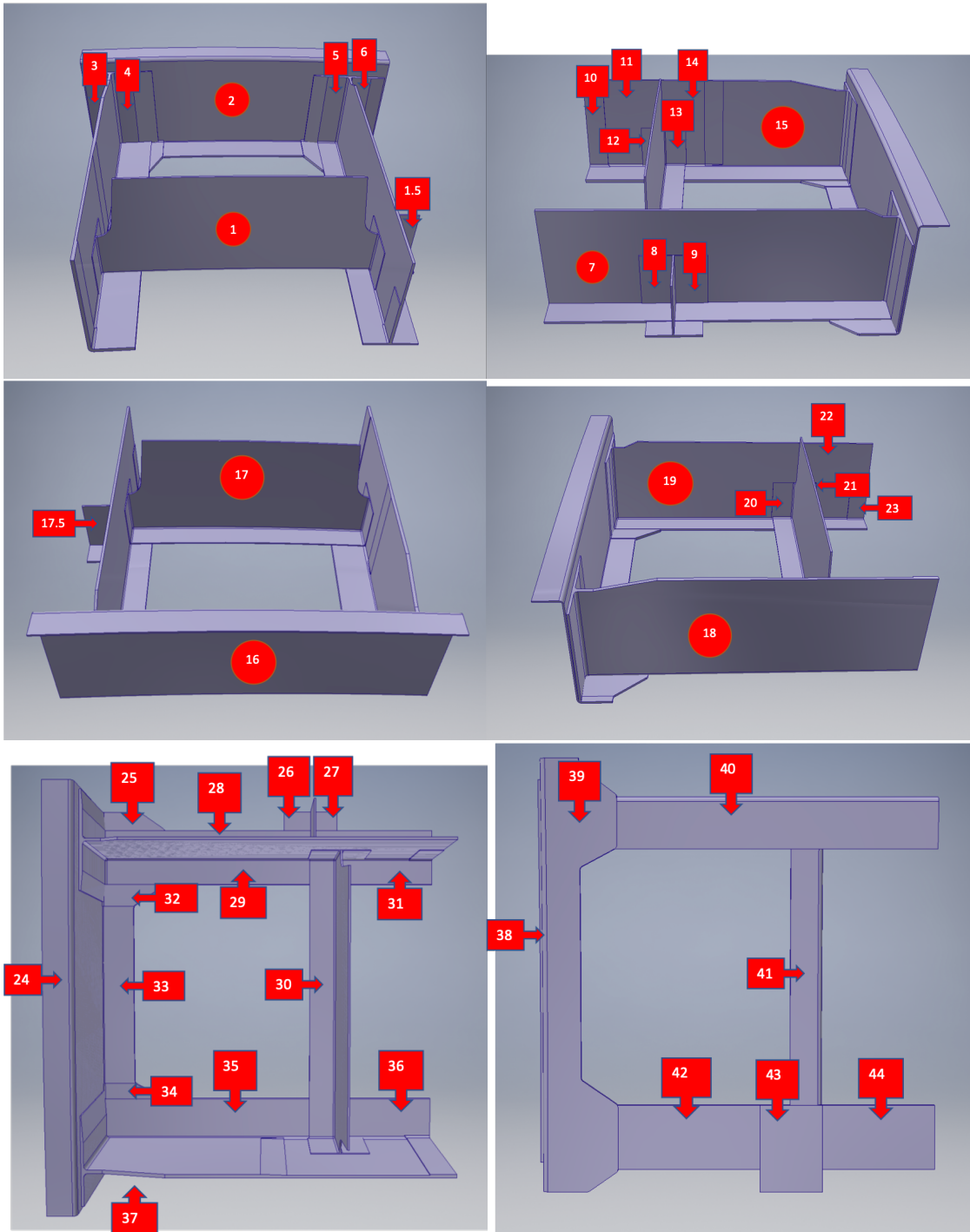

Figure A.1.: Area markers for the non-optimized part.

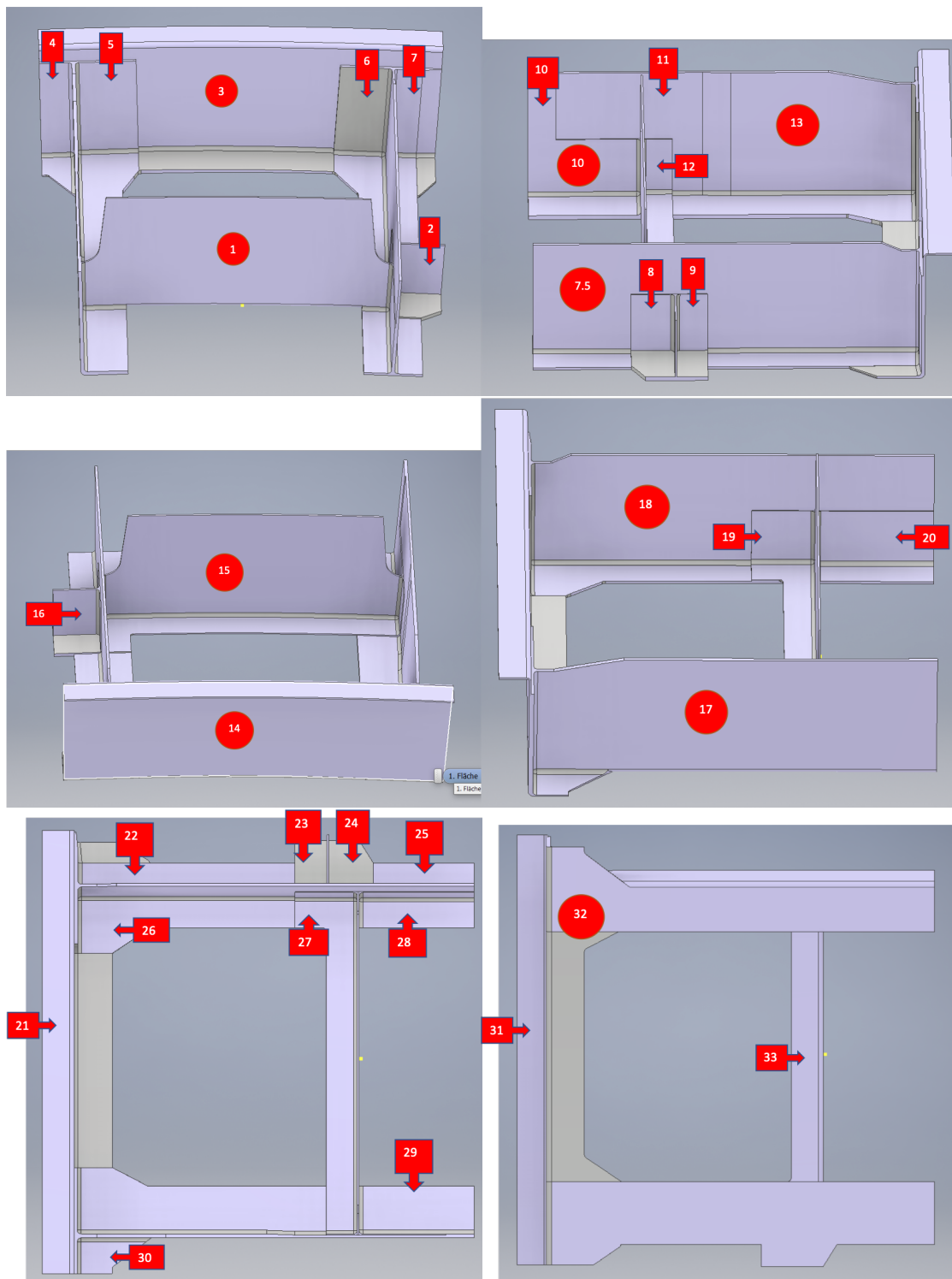

Figure A.2.: Area markers for the optimized part.